



Fisheries
and Environment
Canada

DATA REPORT SERIES No. 77-2

ARCTIC OCEANOGRAPHIC DATA REPORT 1976

PENNY STRAIT

G. S. PECK

DFO - Library / MPO - Bibliothèque



12044592

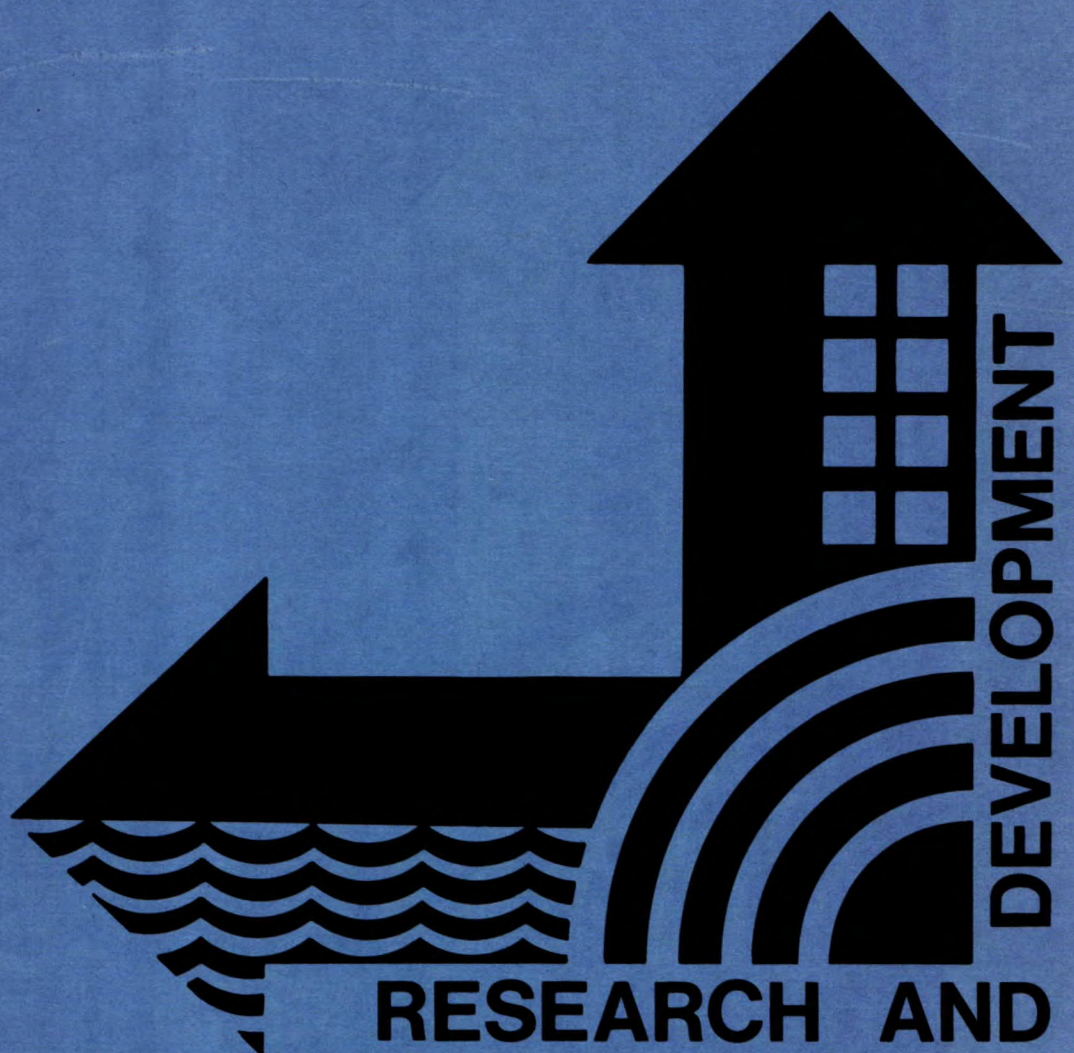

OCEAN AND AQUATIC SCIENCES
CENTRAL REGION

CANADA CENTRE FOR INLAND WATERS
BURLINGTON, ONTARIO

GB
651
C21
no. 77-2

GC
411
A721
1976

ARCTIC OCEANOGRAPHIC DATA REPORT 1976

- PENNY STRAIT -

by

G.S. Peck

Ocean and Aquatic Sciences
Central Region
Department of Fisheries and Environment

Burlington, Ontario

November, 1977

This is an internal technical report which has received only limited circulation. On citing this report the reference should be followed by the words "UNPUBLISHED MANUSCRIPT".

19433

ABSTRACT

This report contains CTD, current, and tidal data collected during a three-week reconnaissance survey in Penny Strait and Belcher Channel, N.W.T., in April, 1976. Beginning in 1977, a separate series of field reports has been instituted. Because there is no formal field report for the survey, certain details, in relation to how the data were collected, are included in this report.

ACKNOWLEDGMENTS

This project was completed thanks largely to the efforts of Mr. S. Baird, Head of the Ocean Instrumentation Section, who formed the other half of the Oceanographic Field Party. Our logistics were greatly simplified through the cooperation of Mr. E.F. Thompson, Hydrographer-In-Charge, and the Hydrographic party at Table Island who shared their base camp with us. The Polar Continental Shelf Project, Energy, Mines and Resources (EMR), supplied fuel and looked after equipment and shipping in Resolute.

The author is also indebted to E. Laurie and K. Harding of Okanagan Helicopters Ltd. who assisted us throughout the project and to E.B. Bennett and L.R. Muir who developed programs used in the analysis of the current meter data. F. Deys and J. Trotoux handled the programming of the CTD data. Mrs. B. Couture typed the manuscript; S.J. Prinsenber, L.R. Muir, and S.D. Baird reviewed the report.

TABLE OF CONTENTS

	<u>Page</u>
Abstract	i
Acknowledgments	iii
Table of Contents	v
List of Figures	vii
List of Tables	ix
1. INTRODUCTION	1
2. DATA COLLECTION	3
2.1 Station Positions	3
2.2 CTD	3
2.3 Current Meters	5
2.4 Tide Gauge	9
3. DATA PROCESSING	10
3.1 Time-Series (Current Meter) Data	10
3.2 Tide Gauge	11
3.3 CTD	11
4. REFERENCES	13
Section I: Hourly Surface Currents	15
Section II: Moored Current Meters	21
Section III: Tidal Data	39
Section IV: CTD Results	45
Appendix A: Chronology of Events	141
Appendix B: Photographs	145

LIST OF FIGURES

	Page
Figure 1: The Canadian Arctic Archipelago	2
Figure 2: 1976 Project Area	4
Figure 3: Near-Surface Current Profiling Arrangement	17
Figure 4: Mooring Configurations - Station 12	23
Figure 5: Record 12M	24
Figure 6: Power Spectrum - 12M	25
Figure 7: Record 12E	26
Figure 8: Tidal Ellipses - 12E	28
Figure 9: Power Spectrum - 12E	29
Figure 10: Mooring Configurations - Station 14	30
Figure 11: Record 14M	31
Figure 12: Tidal Ellipses - 14M	33
Figure 13: Power Spectrum - 14M	34
Figure 14: Record 14E	35
Figure 15: Tidal Ellipses - 14E	37
Figure 16: Power Spectrum - 14E	38
Figure 17: Pelham Bay Water Level Record	41
Figure 18: Height Spectrum - Pelham Bay Tidal Record	44

LIST OF TABLES

	<u>Page</u>
Table 1: Listing of Station Locations	6
Table 2: Hourly Surface Current Data at Station 12	18
Table 3: Hourly Surface Current Data at Station 14	19
Table 4: Results of Tidal Streams Analysis - 12E	27
Table 5: Results of Tidal Streams Analysis - 14M	32
Table 6: Results of Tidal Streams Analysis - 14E	36
Table 7: Tidal Analysis of Pelham Bay Tidal Record	42
Table 8: Luni-Tidal Computations for Pelham Bay	43

1. INTRODUCTION

This report contains the data collected during a three-week reconnaissance survey in Penny Strait and Belcher Channel. The project was initiated through a request by the Department of Indian and Northern Affairs (DINA) to examine surface currents and related physical parameters in Penny Strait which could determine the spread of oil in the event of a mishap (i.e. blow-out, oil spill) in the Sverdrup Basin, an area of intensive oil exploration activity. Of direct concern to DINA and Department of Fisheries and the Environment (DFE) would be the ultimate spread of oil to Lancaster Sound which is known to be an area of very high biological productivity.

The objectives of the project were to:

- 1) obtain S, T, σ_t data across Penny Strait along a transect from Cape Sir John Franklin (Grinnell Peninsula, Devon Island) to Cape Kitson (Bathurst Island). The transect was to be completed several times to average out tidal effects, thereby leaving quasi-steady-state conditions from which geostrophic transport could be computed;
- 2) gather time-series records of currents under the ice at two locations in the transect; and
- 3) take hourly measurements of near-surface currents and temperature/salinity profiles over a period of 13 hours at the two mooring sites.

Field logistics were simplified through the cooperation of the Polar Continental Shelf Project and the Canadian Hydrographic Service of Central Region, Ocean and Aquatic Sciences (OAS), whose base camp off Table Island in Belcher Channel was used for the base of the oceanographic project.

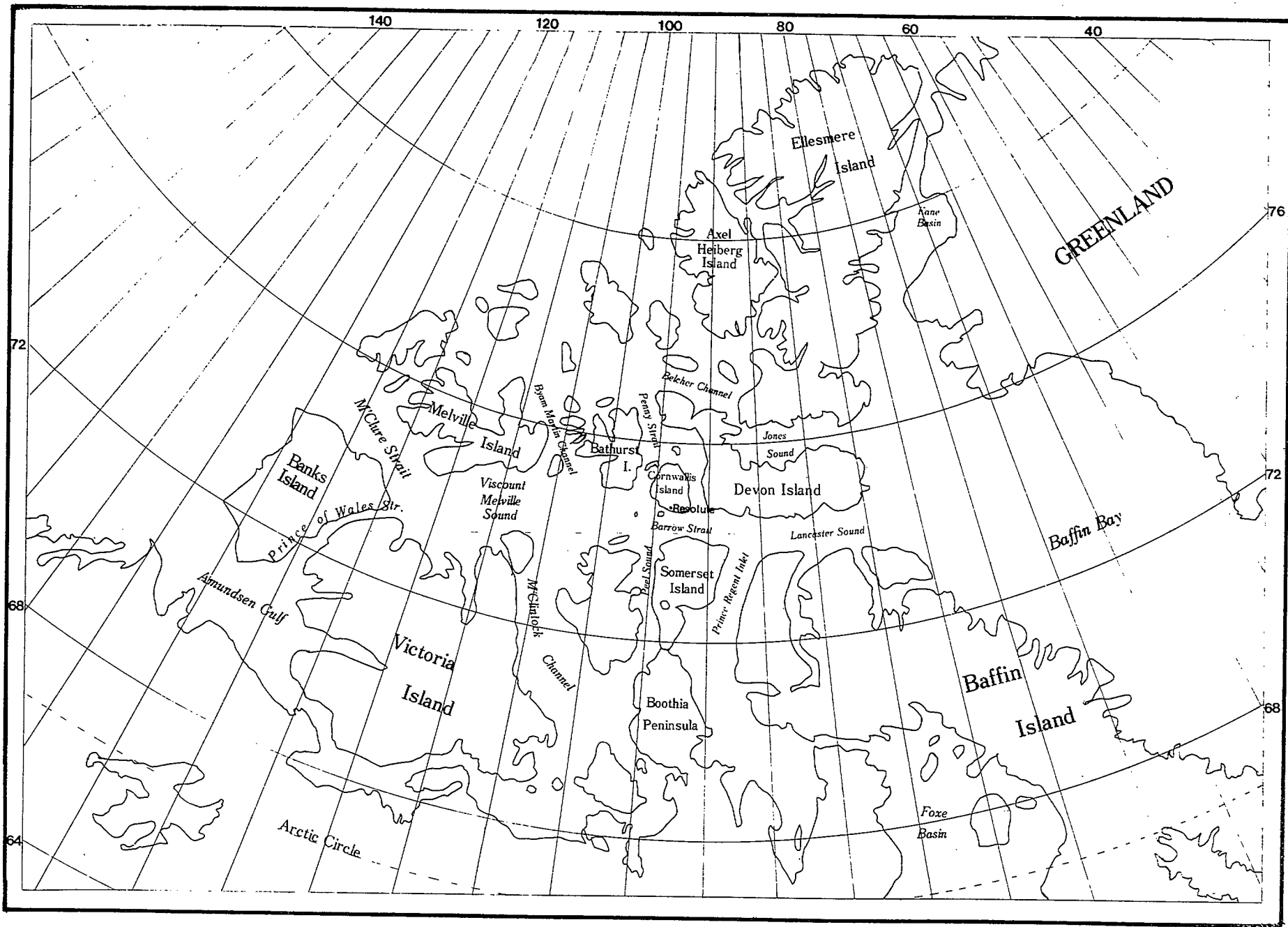

Figure 1: The Canadian Arctic Archipelago.

2. DATA COLLECTION

2.1 Station Positions

Six CTD stations across Penny Strait were established on April 8th by dead reckoning (direction and elapsed time) and marked by aluminum poles with one metre square flags of signal cloth. Current meters were moored and 14 hourly CTD casts and near-surface current readings were taken at two of the stations (12 and 14). When CTD sampling across the transect resumed on April 20th, one of the six stations could not be located. It was noted that a large area of ice several hundred metres across had uplifted in the vicinity of station 15 and the marker pole was presumed lost in the crunch. Station 15 was re-established by dead reckoning and the new position was also marked by a pole and flag. The stations were accurately fixed on April 21st when the Hydrographic Service carried out a detailed survey in the vicinity using a Mini-Ranger III positioning system (Thompson, 1976). An extra station, 17, was sampled on the last crossing.

A second CTD transect of 6 stations across Belcher Channel was carried out with a helicopter carrying a Mini-Ranger system. Figure 2 shows the survey area and station positions.

2.2 CTD

A guildline Mark IV CTD system was tried initially, but a faulty integrated circuit in the auto-scaling circuitry (diagnosed later in Burlington) resulted in erratic temperatures which affected salinity and sigma-t computations (the Mark IV computes salinity from temperature and conductivity ratio). The back-up system, a modified Aanderaa RCM4 current meter, was used to obtain the CTD data presented here.

The modifications involved removing the vane and rotor and then increasing the resolution of the temperature and conductivity measurements. This was done by decreasing the ranges through offsetting the self-balancing bridge within the device. Although a 200 psi (approximately 150m) pressure (depth) sensor was in place, the cable was marked at set depths (see section 3.1) since the pressure range was exceeded. Modifications and calibrations

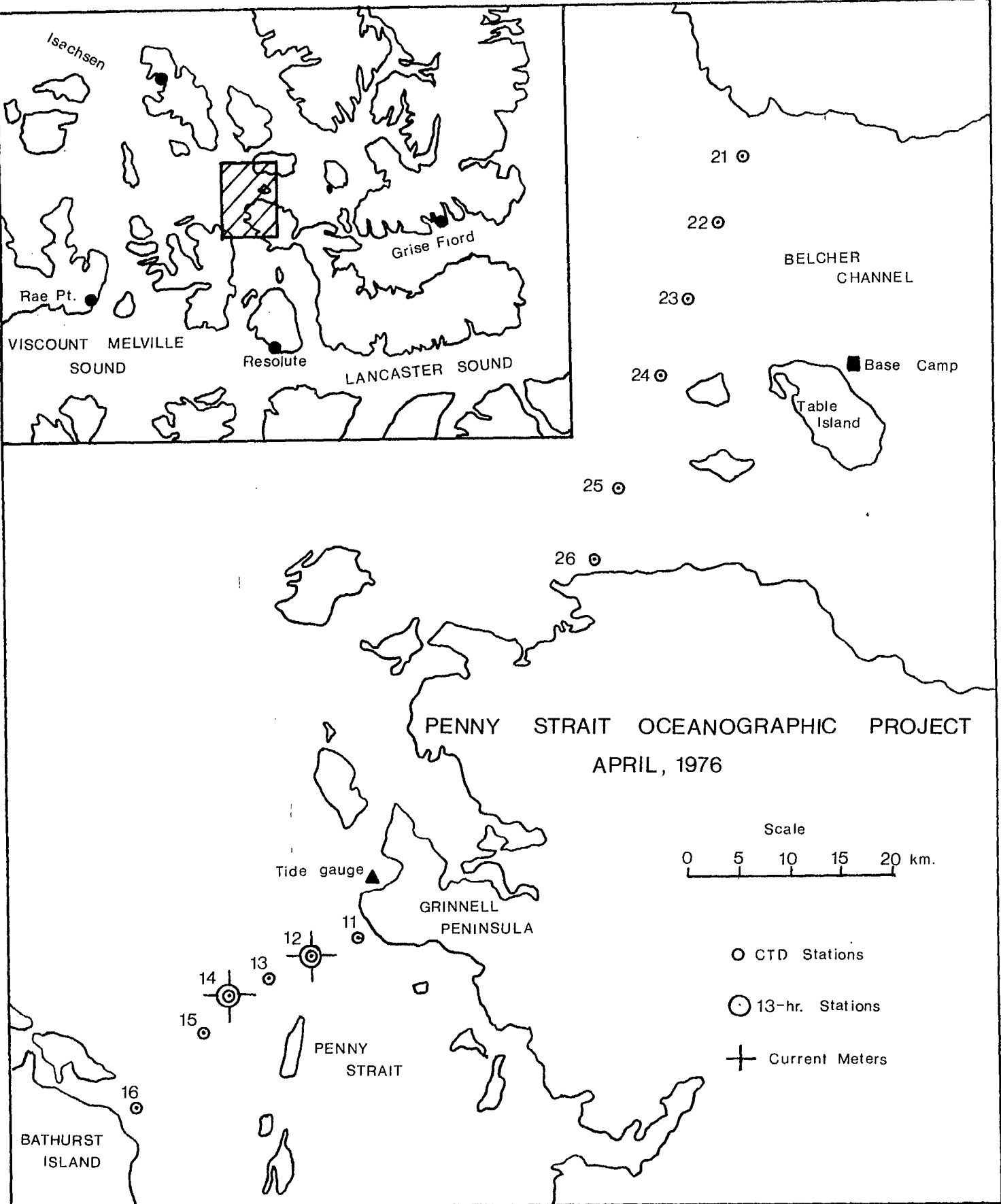

Figure 2: 1976 Project Area

were carried out at Canada Centre for Inland Waters (CCIW). Specified accuracies for the device (Baird, 1976) are: $\pm 0.10 \text{ mmho cm}^{-1}$ (Conductivity) and ± 0.05 degrees Celsius (temperature).

A prototype lightweight portable winch (Brooks, 1977) built at CCIW was used with the CTD, incorporating single-conductor armourgraph cable (0.142" O.D.) and a set of slip-rings connected to the shaft of the winch. The bottom half of a small outboard engine was linked to the shaft by a chain and an adapter shaft constructed to couple the engine propeller drive (now the winch axle) with a Jiffy ice auger engine. The outboard's gear shift was kept, so the gas engine could raise or lower the probe or idle in neutral (with the brake set). A crank could be fitted directly to the shaft for raising or lowering by hand. Total weight of the winch plus cable was about 35 kg (90 pounds).

A total of 62 CTD casts were taken with the RCM4; the particulars are listed in Table 1.

2.3 Current Meters

Two Marsh-McBirney model 501 electromagnetic current meters were borrowed from CCIW and three Endeco 720 electromagnetic meters were leased from Endeco (Environmental Devices Corporation, Marion, Massachusetts, U.S.A.). One of each type was moored at both stations 12 and 14, and the third Endeco was used during the 13-hour stations with an Endeco 727-4 surface display unit. All four moored instruments were connected to identical battery packs developed and built by the Engineering Section at CCIW. To keep the batteries reasonably warm, the packs were submerged below the ice (secured to the mooring brackets) in water at ambient temperatures around -1.8°C . The packs contained both power supply and a Rustrak analog recorder.

Both current meters have two-axis electromagnetic sensors and, by referencing the brackets to true north at the surface (aligning them with the helicopter's gyro), the XY outputs corresponded to the east-west and north-south components of the current (standard notation; u positive east, v positive north). Ranges and accuracies of each component of the instruments are: Endeco 0-200 cm sec^{-1} ($\pm 2.0 \text{ cm sec}^{-1}$), and Marsh-McBirney 0-100 cm sec^{-1} ($\pm 2.0 \text{ cm sec}^{-1}$).

TABLE 1

Listing of Station Locations

Station	Position		Depth (m)	Ice (m)	No. of Casts
	Latitude (N)	Longitude (W)			
<u>Transect 10 - Penny Strait</u>					
11	76° 42.8'	96° 58.7'	192	0.8	5
12	76° 41.5'	97° 07.0'	187	0.8	19
17	76° 40.2'	97° 12.0'	300 e	0.7	1
13	76° 39.8'	97° 16.6'	220	0.7	4
14	76° 38.5'	97° 23.8'	260	2.0	18
15 *	76° 36.3'	97° 28.6'	190	0.5	4
16	76° 31.4'	97° 42.8'	225	0.7	4
<u>Transect 20 - Belcher Channel</u>					
21	77° 26.0'	95° 53.1'	59	1.0	2
22	77° 22.4'	95° 57.0'	68	1.5	1
23	77° 18.3'	96° 01.8'	127	2.0	1
24	77° 14.5'	96° 05.9'	220	1.5	1
25	77° 07.9'	96° 13.0'	180	1.5	1
26	77° 03.6'	96° 17.7'	200	2.1	1
Total					62

* Because the flag marking the original position of the station was never found, the first two casts at this station were taken at roughly this vicinity before a new flag was set out. The information in the table refers to casts 3 and 4.

e Estimated depth (from chart). All other depths were determined by the Hydrographic Service during their survey.

12M and 12E (Marsh-McBirney and Endeco current meters, respectively at station 12) were moored on April 13th and recovered by the Hydrographic Service (upon completion of their survey) on May 6th. 14M and 14E recorded from April 17th to May 7th.

Data from all four instruments are presented in this report. Besides the instances of sensor malfunction discussed below, the Marsh-McBirney and Endeco current records differ fundamentally in one respect. 12M (both components) and 14M (v component only) exhibit a low-frequency, high-amplitude ($\approx 25 \text{ cm sec}^{-1}$) oscillation of three to ten days' periodicity. These oscillations do not correlate with surface pressure records obtained from weather stations. Moreover, 12M and 14M are not in agreement with each other. A physical phenomenon of this magnitude should have been detected by the Endeco meters; that this didn't happen suggests an instrumentation problem. Although the Endecos could be suspected, it would be unlikely that instruments capable of measuring higher frequency phenomena (including tidal) could not detect long-period effects. Because the two Marsh-McBirneys don't correlate, they are suspect.

A forthcoming report will discuss various problems associated with the use of electromagnetic current meters and will include details of the calibrations and tests carried out on these instruments. At present, it is believed this phenomenon is either the result of zero drifting of the Marsh-McBirneys, frequency differences between the two types of instruments, or both. As the analyses show, tidal phenomena seem to be reasonably well-reproduced by all of the instruments.

There were obvious sensor malfunctions evidenced in the record of 12M on three occasions. At about 0330Z on April 22nd, both the u and v analog traces jumped up in scale (towards the positive) the equivalent of about 26 cm sec^{-1} each. A sudden voltage increase was originally suspected, but post-project calibrations revealed no net zero displacement; therefore the voltage surge would have had to die out before the end of the record. A close examination of the record for twelve hours before and after the jump couldn't detect any trend resembling a voltage decrease. Therefore, a time error caused by a stoppage of the motor drive is suspected. The other two instances involved the u component only. From May 1st to 3rd, the u trace degenerated into a scatter over a range of 60 cm sec^{-1} from which no mean trend could be

detected. It returned to normal briefly before scattering again from May 5th to the end of the record. Because these problems have not yet been resolved, 12M should be considered good only from April 13th to 22nd. The full u and v and low-pass filtered records are included, but a tidal streams analysis was not attempted for such a short period. The power spectrum for the first half is presented. Since hourly data were used for the CALCØMP plots, the jump is not discernible.

12E has a definite positive offset, but both pre- and post-project calibrations showed no net zero drift. Only the mean drift is affected and has therefore been excluded from the results of the tidal streams analysis.

All three Endecos use the same convention for east-west and north-south components, but depart from the standard; i.e. $X = v$ and $Y = -u$ when the instruments are affixed as described previously. Although this wasn't noticed in pre-calibration tow tests, post-calibration tests bore this out, and the data have been transformed.

When power spectra (section 3.2) of the four records were computed, the energy at significant (diurnal and semi-diurnal) peaks was found to be four times higher (and, therefore, speed two times higher) in 12M and 14M when compared to 12E and 14E. The Rustrak recorders and battery packs are designed to work with the Marsh-McBirney current meters, receiving outputs of $\pm 2v$ corresponding to $\pm 100 \text{ cm sec}^{-1}$. The Endeco outputs, however, are $\pm 1v$ for $\pm 100 \text{ cm sec}^{-1}$. Pre-project tests were made in the CCIW tow tank, but outputs were monitored on a different recorder than was used in the field. Although the difference in voltage outputs was to be taken into account in modifying two battery packs, this was evidently not done. Analog traces from the Rustraks were compared, and identifiable events were found to be in the ratio of about 2:1 (Marsh-McBirney to Endeco). In comparing the moored current values with the 13-hour data (in which an Endeco surface display was used in conjunction with an Endeco current meter), it was found that multiplying the recorded Endeco values by 2.0 gave good agreement with the Marsh-McBirney and Endeco read-out data. Therefore, both 12E and 14E were multiplied by 2.0. This still does not account for the low-frequency problems related earlier.

The 13-hour data have been transformed to the standard u,v notation and are presented in Tables 2 and 3 (Section I).

2.4 Tide Gauge

An Aanderaa submersible tide gauge was installed in Pelham Bay as part of the Hydrographic program, recording from March 16th to April 22nd. Harmonic analysis was done by the Tides and Water Levels Section of the Hydrographic Service (Burlington).

3. DATA PROCESSING

3.1 Time-Series (Current Meter) Data

The Rustrak recorder plots the outputs from two channels by switching from one to the other every two seconds. All four instruments had time errors; in each case the recorder was about 2 hours slow, which is well within the $\pm 2\%$ specification of the motor drive. These errors were taken as linear throughout the records, and, after compensating for them, the records were digitized at 15-minute intervals. The digitized records underwent tidal streams (harmonic) and power spectral analyses, the results of which are presented in the following order:

Tidal Streams Analysis

The amplitude and phase of the mean and 18 tidal constituents were determined from the data, using hourly data (every fourth digitized value). Current predictions were produced from the constituents (i.e. $u - PR$) and compared to the recorded values (u), the difference being $u - ER$. The data is also run through a low-pass filter ($A_{24}A_{24}A_{25}$ for hourly values), yielding $u - LP$. The eight time-series plots are, starting from the top:

- 1) $u - LP$ is the low-pass filtered u component;
- 2) u is the observed u component;
- 3) $u - PR$ is the predicted u component (including the low-passed values $u - LP$);
- 4) $u - ER$ is the difference between 2) and 3); and
- 5) to 8) correspond to 4) to 1) for the v component.

Speeds are in cm sec^{-1} , and the time interval is one day.

The results of the analysis are also included in tabular form followed by a set of constituent ellipses. The table lists the name of the constituent, its period in hours, the lengths of the major and minor axes of the ellipse in cm sec^{-1} , the inclination of the major axis in degrees counter-clockwise from east, and the Greenwich phase lag in degrees referred to GMT. If the minor axis is positive, the current vector rotates counter-clockwise; a negative value indicates clockwise rotation.

Spectral Analysis

Power spectra were computed from the 15-minute digitized data, and the results are presented as log-log plots of kinetic energy density ($\text{cm}^2\text{sec}^{-2}\text{cph}^{-1}$) versus period (hours). 124 frequency bands were used and the degrees of freedom (number of points divided by the number of bands) in each case were calculated to determine the 95 and 90% confidence levels shown on the plots.

3.2 Tidal Data

Figure 17 shows the Pelham Bay tidal record obtained by the Hydrographic Service. The water levels are relative heights only since the tide gauges were not referenced to a chart datum, and total pressure (including atmospheric) is given. Figure 18 is the log-log plot of the spectral analysis results; the variance of the height ($\text{cm}^2\text{cph}^{-1}$) is plotted versus the period (hours). 640 hourly water level values (March 24th to April 22nd) were used and the number of bands was 62. 95 and 90% confidence levels are plotted on the diagram.

The results of the harmonic analysis (carried out by the Tides and Water Levels Section) are presented in Tables 7 and 8. This information also appears in Thompson (1976).

3.3 CTD

The RCM4 was fired from the surface with an S-10 printer/calculator. Initial readings were taken at 2m (or bottom of the ice), then 5m intervals from 5 to 50m, 10m intervals to 100 and then every 25m to 200m (the exception being station 17 where a maximum depth of 275m was reached). Later this was altered to 2m (surface) and 10m intervals from 10 to 100m and 25m intervals below that. The cable was marked for ease of reference. After 42 casts, an error was discovered upon remeasuring the cable. Subsequently, the depths below 100m of the first 42 stations were corrected.

Values of temperature, conductivity, and depth were sent up the cable as ten-bit binary words which were transcribed by the S-10 printer into values from 0 to 1023. Calibration coefficients previously determined

for the individual current meters were stored in programs on a Hewlett-Packard 9820 calculator which were used to convert the "Aanderaa bits" into depth (m), temperature ($^{\circ}\text{C}$), and conductivity (mmho cm^{-1}). Programs were also included to calculate salinity from Bennett's formula (Walker and Chapman, 1973), sigma-t, and sound velocity.

Of the three remaining channels (instrument identification, current speed, direction), only the first was used as a check on instrument performance.

Each of the 62 CTD profiles is identified by three numbers (i.e., 14 17 45, which means that this profile was taken at station 14, it was the 17th profile taken at this station, and the 45th consecutive profile). All times are GMT (CST + 6 hours), and the date is day, month, and year. OKC and AJR are call signs of the two helicopters used (C-GOKC and C-GAJR). TENT refers to the CELL Arctic tent used for the 13-hour stations. Ice thickness is in metres.

The RCM4 records CTD values at discrete bits from 0 to 1023, and sometimes a printed value can be ± 1 bit (even the reference number, normally a constant, can vary). Thus, sometimes the initial calculations using temperature and conductivity showed a slight instability in salinity (and therefore also in sigma-t). These are attributed to the data collecting system rather than local instability. Where data have been corrected (usually a bit is added or subtracted to the conductivity value), a number 2 appears next to the changed value (i.e. station 14 14 28, salinity at 35m). By changing only the bits, the corrected salinity and sigma-t values have the same accuracies as the rest of the data. Interpolation between computed salinity values above and below the data point in question could have resulted in a value which couldn't have been directly measured by the system.

T, S, and σ_t plots were made from the data by linear connections of the data points.

4. REFERENCES

- Baird, S.D. 1976. RCM Cost and Availability. Internal Report, Ocean and Aquatic Sciences, Central Region, Department of the Environment, Burlington.
- Brooks, D.J. 1977. A Lightweight Portable Power-Driven Winch for Arctic CTD Operation. Technical Note Series 77-1, Ocean and Aquatic Sciences, Central Region, Department of Fisheries and Environment, Burlington.
- Thompson, E.F. 1976. Final Field Report, P.C.S.P. Survey - Belcher Channel and Penny Strait. Canadian Hydrographic Service, Ocean and Aquatic Sciences, Central Region, Department of the Environment, Burlington.
- Walker, E.R. and K.D. Chapman. 1973. Salinity-Conductivity Formulae Compared. Pacific Marine Science Report 73-5, Marine Sciences Directorate, Pacific Region, Department of the Environment.

SECTION I

HOURLY SURFACE CURRENTS

13-Hr Stations

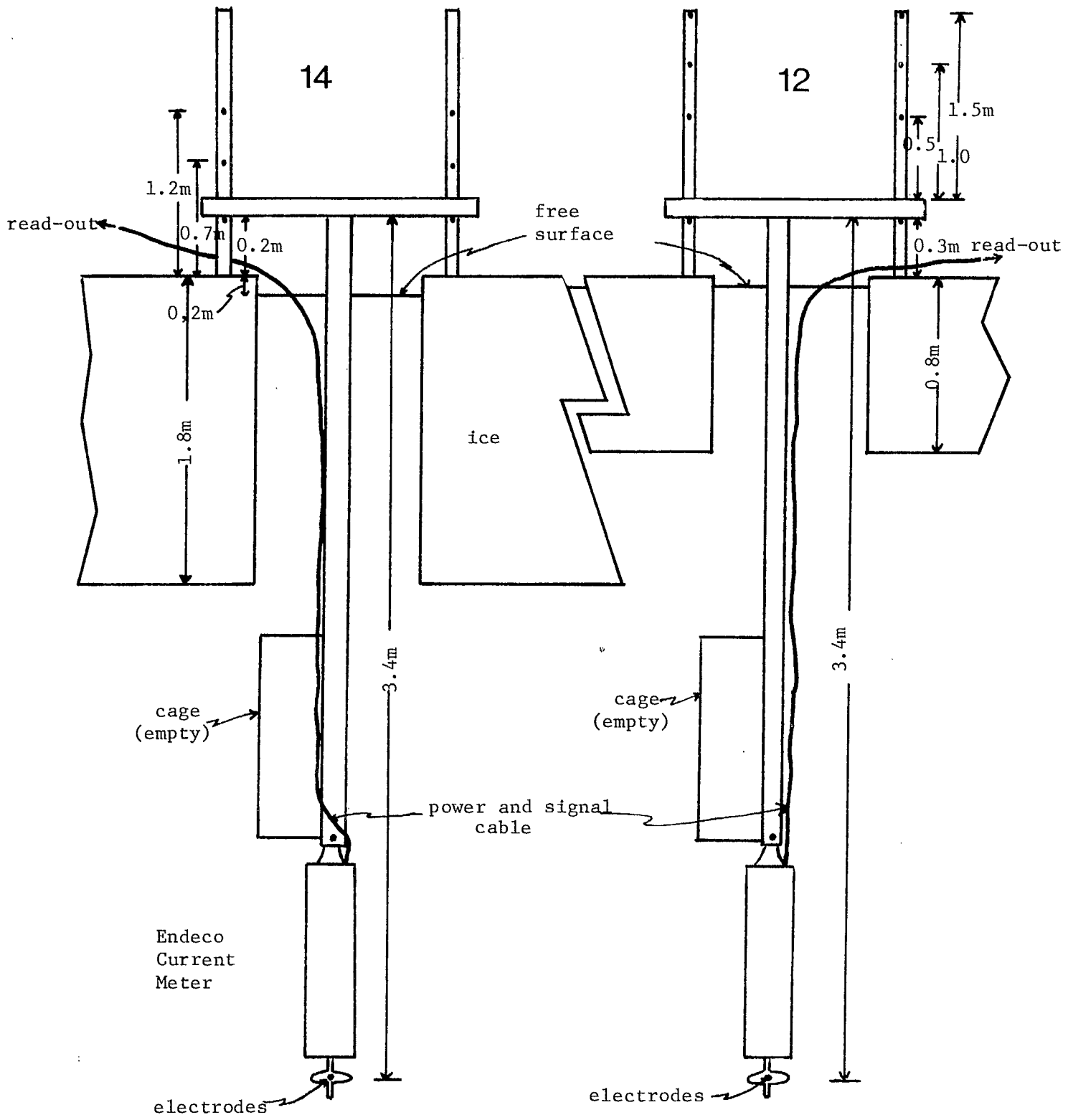

Figure 3: Near-Surface Current Profiling Arrangement.

TABLE 2

Hourly Surface Current Data at Station 12

Station 12: 13-14 April, 1976 Speeds in cm sec^{-1} Depths (m) are from Surface; Ice = 0.8m									
Time (GMT)	Depth (m)	1.0		1.5		2.0		3.0	
		u	v	u	v	u	v	u	v
1810		3	0	-	-	9	-5	10	-6
1850		1	-2	-	-	2	-4	1	-3
1955		0	6	-5	10	-7	14	-8	13
2050		2	6	-3	12	-3	14	-5	15
2200		-1	2	-10	0	-13	2	-14	1
2305		2	8	0	16	0	21	2	24
2355		4	1	9	3	9	4	8	5
0055		2	-2	4	-5	4	-8	4	-7
0150		8	-2	17	-3	20	-7	21	-6
0255		7	0	19	-6	21	-9	27	-10
0350		3	0	7	-8	5	-13	9	-14
0450		8	-6	21	-11	17	-17	18	-21
0550		0	0	-	-	3	0	8	-2
0650		5	0	-9	3	9	1	9	-1

TABLE 3

Hourly Surface Current Data at Station 14

Station 14: 16-17 April, 1976 Speeds in cm sec^{-1} Depths (m) are from Surface; Ice = 1.8m						
Depth (m) Time (GMT)	2.0		2.5		3.0	
	u	v	u	v	u	v
1625	8	-4	13	-6	13	-8
1730	-1	-10	2	-13	2	-14
1825	12	-9	16	-9	15	-10
1925	11	4	11	7	11	7
2015	1	16	2	17	4	19
2105	-1	15	-2	15	-4	17
2205	4	6	4	6	5	9
2305	-3	-1	-2	-1	-3	0
0005	-4	-7	-4	-8	-4	-9
0105	0	-2	-1	-2	-1	-3
0205	5	1	6	2	6	2
0305	22	-11	21	-10	24	-9
0405	20	-13	20	-14	19	-15
0505	7	-21	12	-29	16	-24

SECTION II

MOORED CURRENT METERS

Station 12

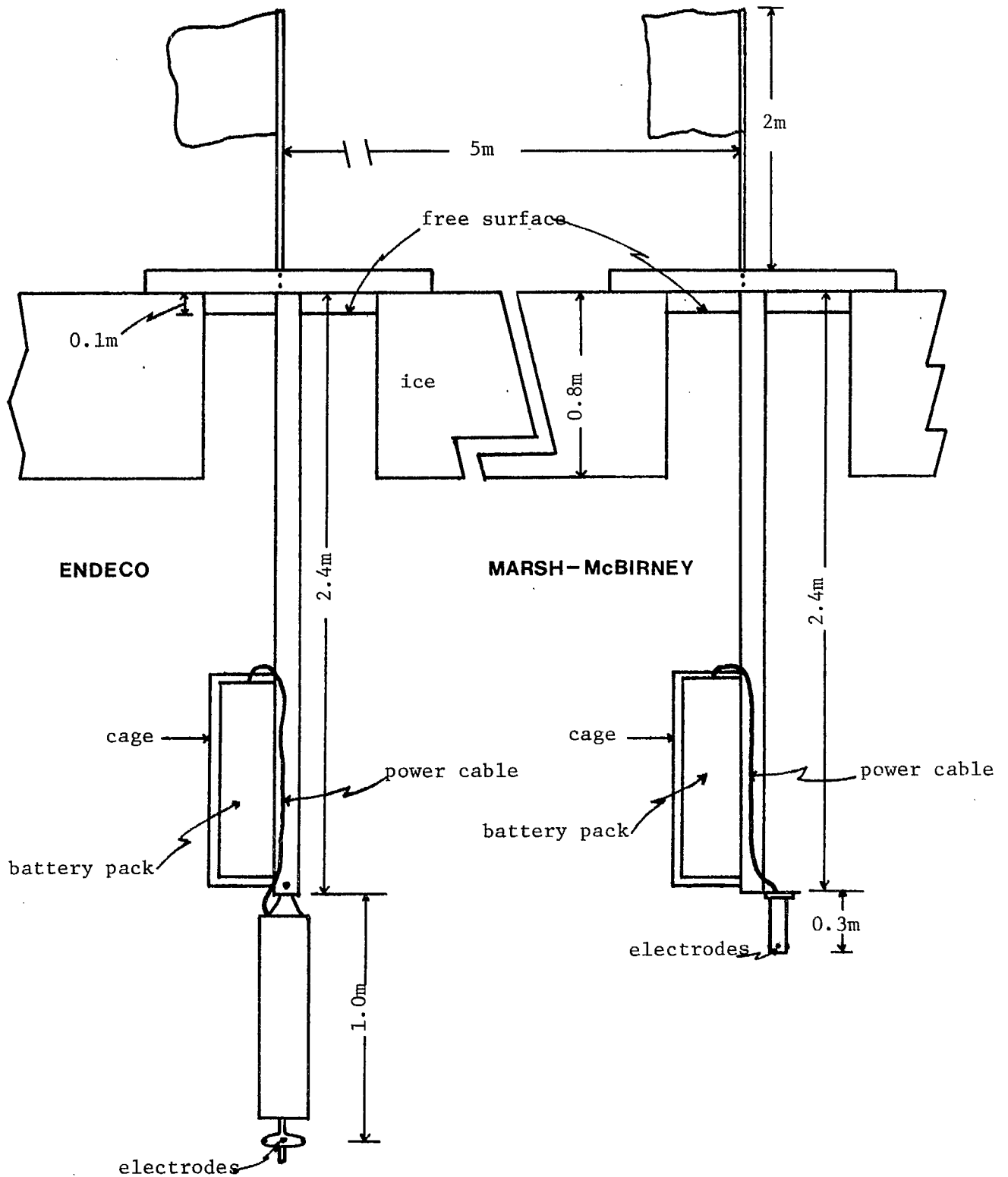
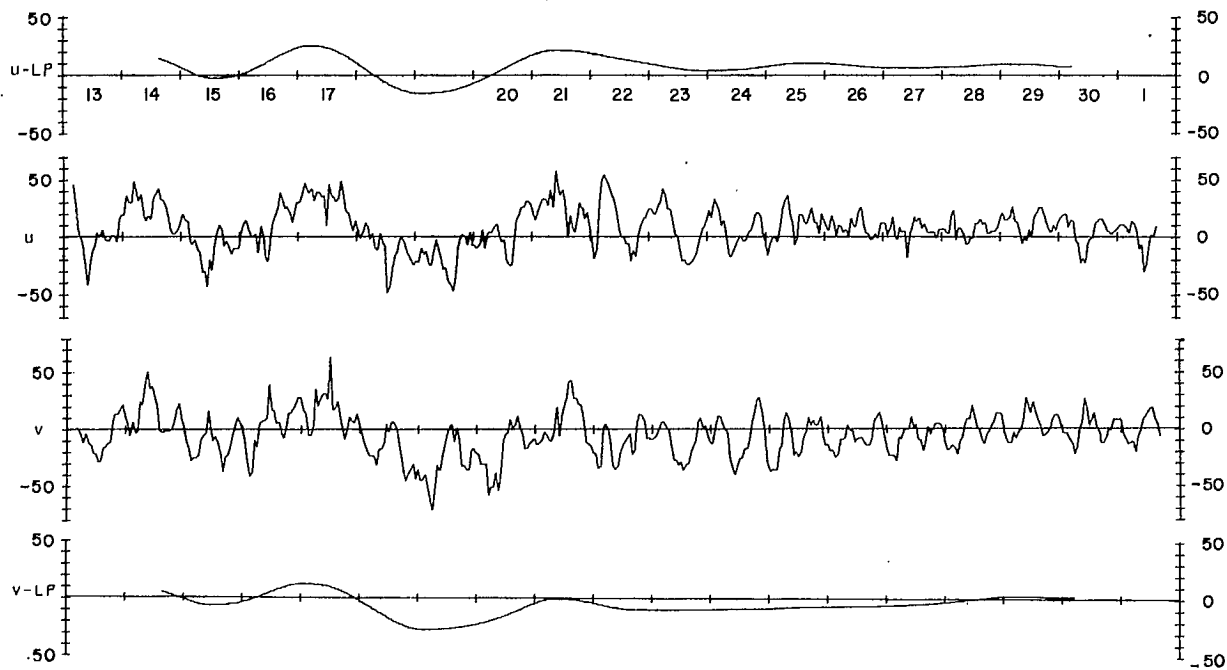

Figure 4: Mooring Configurations - Station 12



STATION 12 M

13 APRIL - 1 MAY, 1976

Z = 2.7 M

Figure 5: Record 12M.

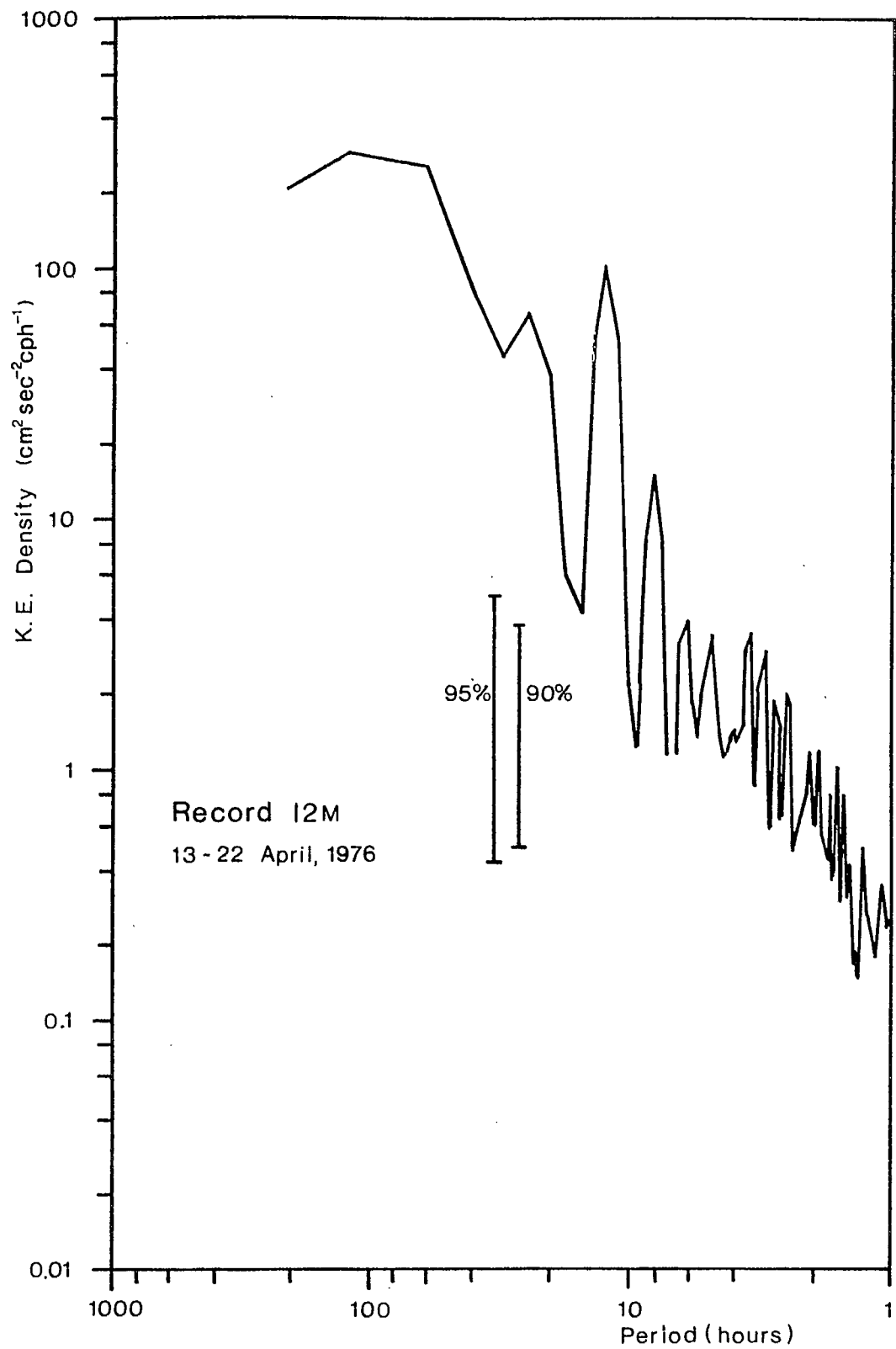
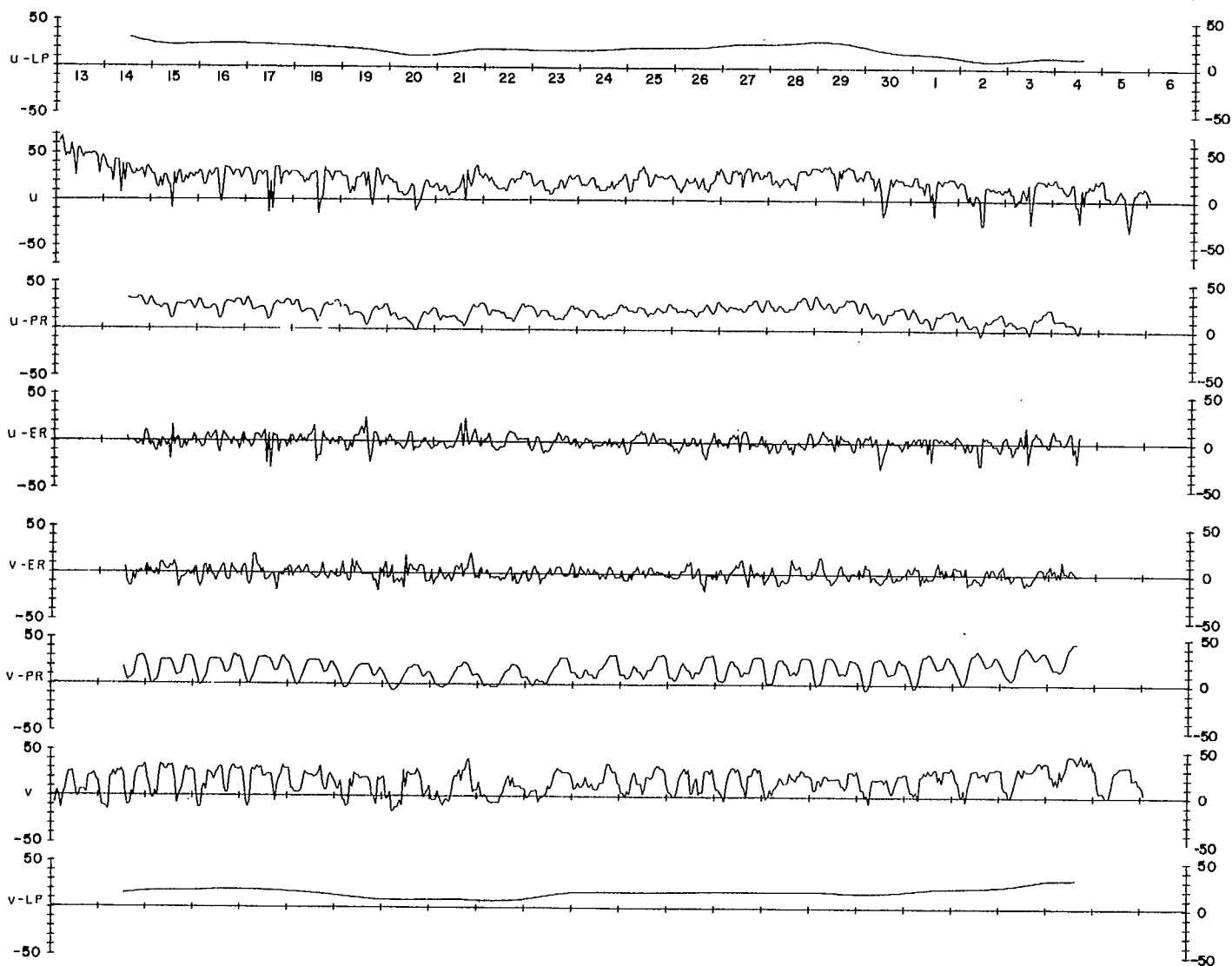

Figure 6: Power Spectrum - 12M.



STATION 12 E

13 APRIL - 6 MAY, 1976

Z = 3.4 M

Figure 7: Record 12E.

TABLE 4

Results of Tidal Streams Analysis - 12E

12E 13 April - 7 May, 1976 Tidal Streams Analysis Results					
Name	Period (hours)	Major Axis (cm sec ⁻¹)	Minor Axis (cm sec ⁻¹)	Inclination (degrees)	Phase Lag (degrees)
MSF	354.37	8.659	3.204	178.4	152.5
O ₁	25.82	4.735	-2.184	115.2	311.5
K ₁	23.93	8.511	-4.975	81.1	41.4
M ₂	12.42	7.394	-0.132	105.5	293.7
S ₂	12.00	5.658	1.080	80.3	299.4
2SM ₂	11.61	1.368	-0.276	159.4	315.3
M ₃	8.28	1.585	-1.114	43.3	68.3
SK ₃	7.99	2.352	-1.224	36.2	147.4
M ₄	6.21	2.560	-0.675	29.8	50.0
MS ₄	6.10	1.433	0.306	26.1	127.6
S ₄	6.00	0.769	-0.104	49.8	93.5
2MSO ₅	4.97	1.585	-0.531	37.7	49.8
M ₆	4.14	0.917	0.275	171.8	166.1
2MS ₆	4.09	1.329	-0.355	52.3	27.8
2SM ₆	4.04	0.956	-0.056	95.6	343.0
M ₈	3.10	0.826	-0.180	54.0	176.3
3MS ₈	3.08	0.897	0.568	45.2	92.6
M ₁₂	2.07	0.433	-0.097	8.4	54.2

Record 12 E

13 April - 6 May, 1976

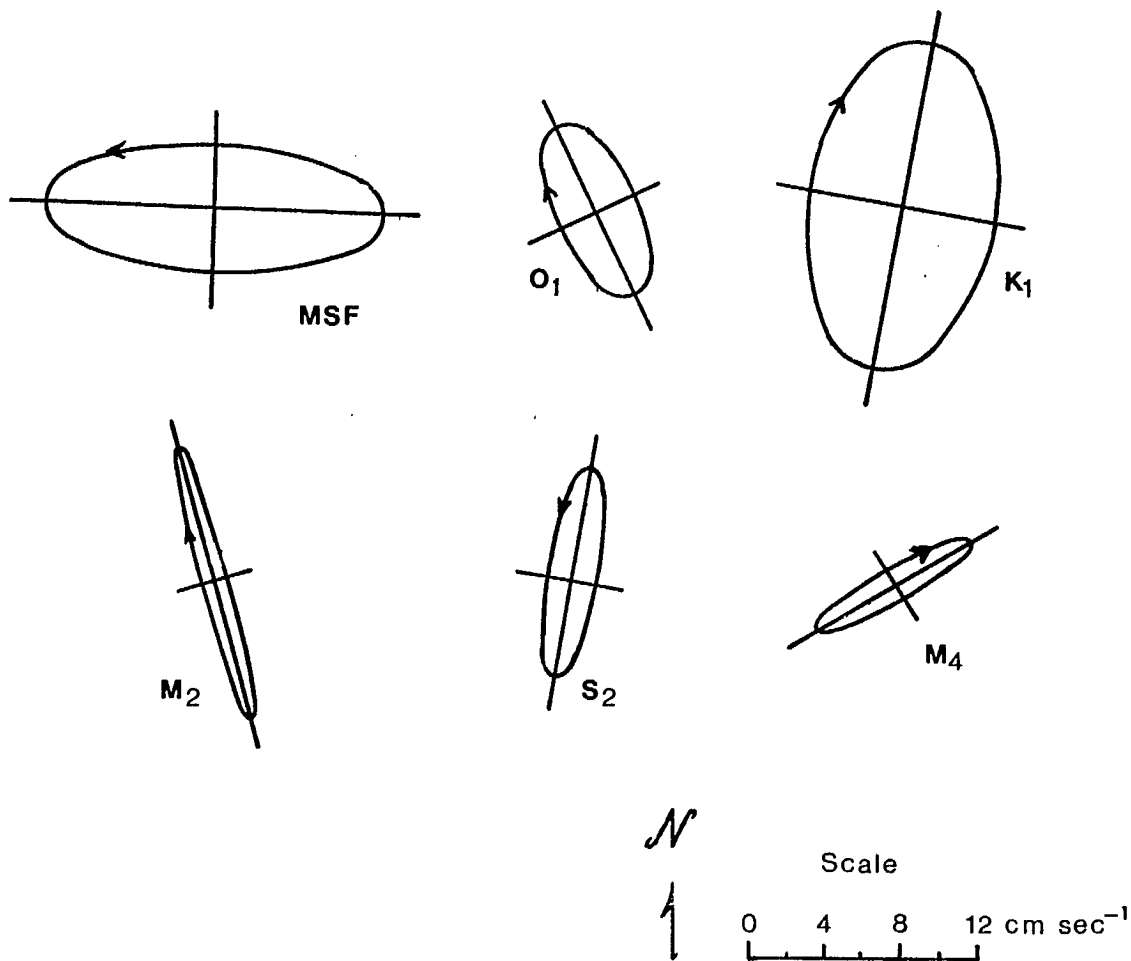

Figure 8: Tidal Ellipses - 12E.

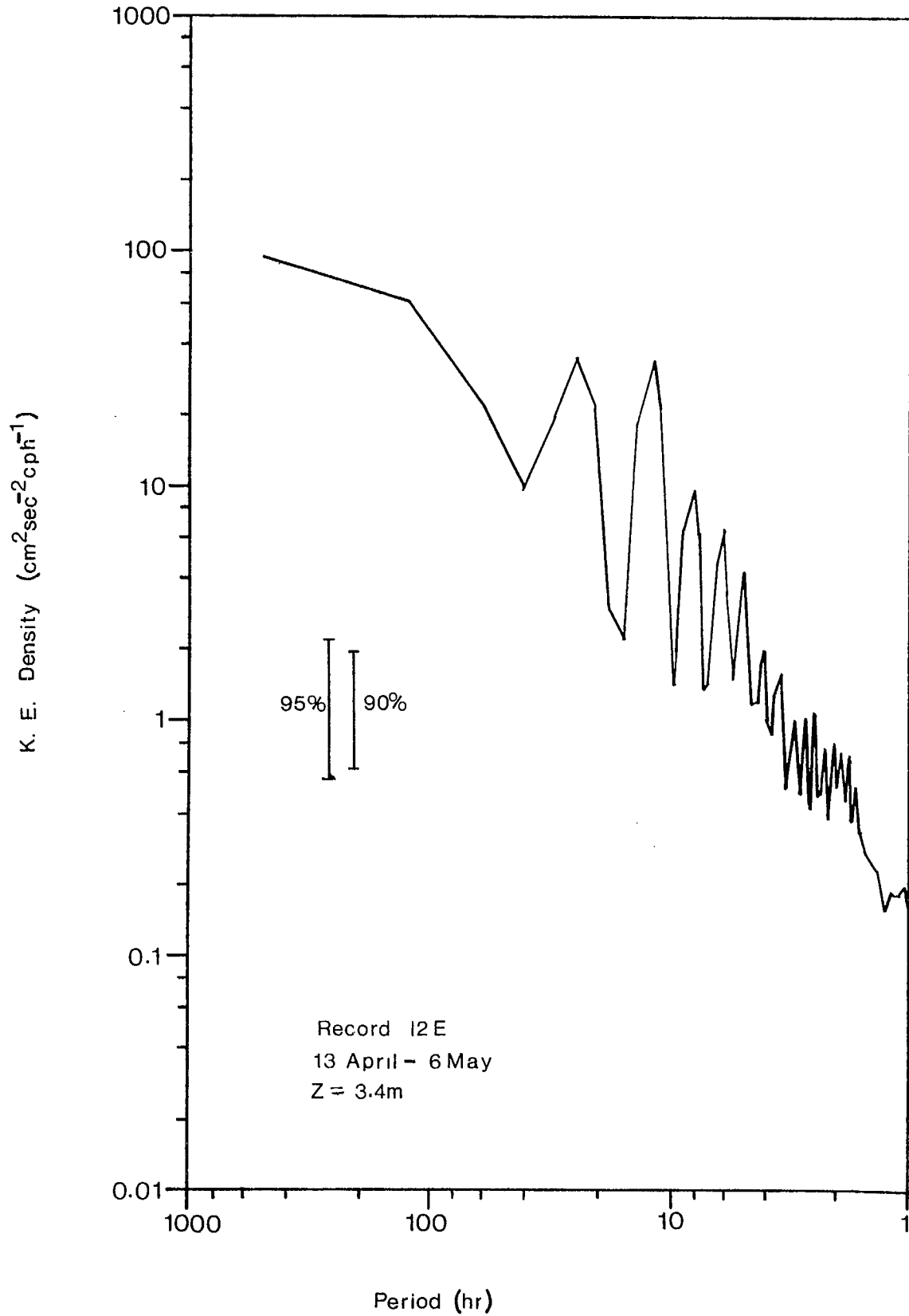

Figure 9: Power Spectrum - 12E

Station 14

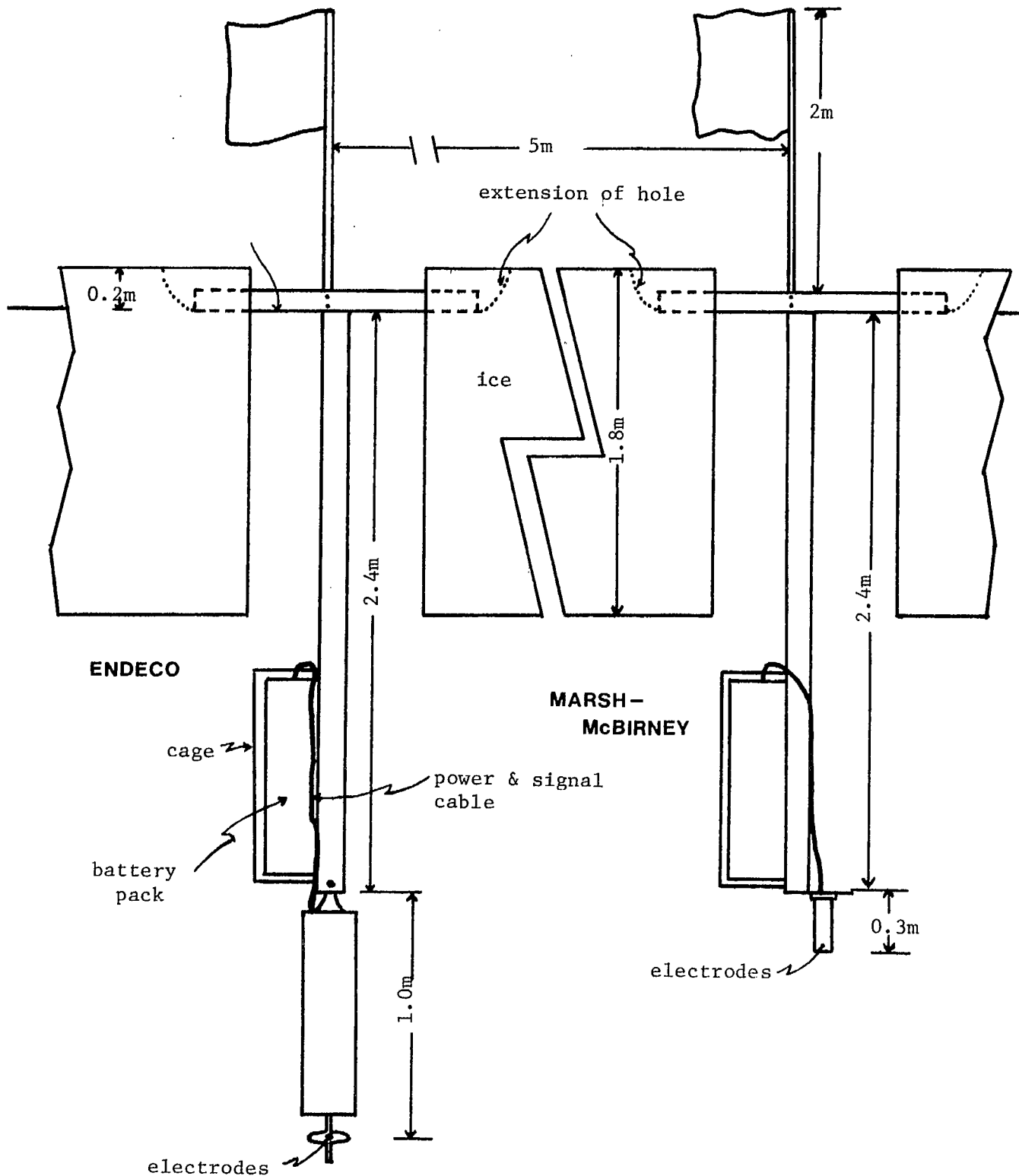

Figure 10: Mooring Configurations - Station 14.

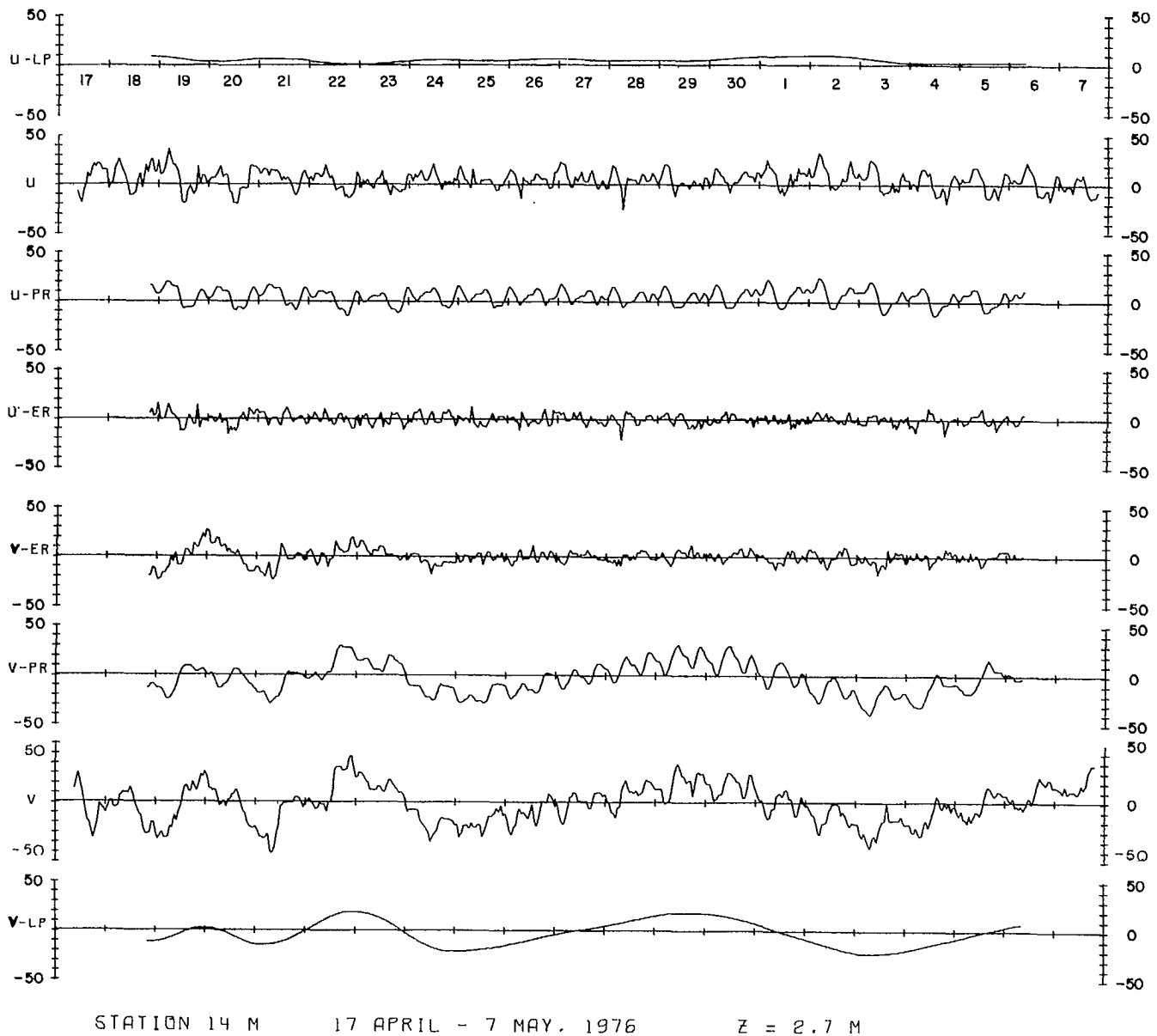

Figure 11: Record 14M.

TABLE 5

Results of Tidal Streams Analysis - 14M

14M 17 April - 7 May, 1976 Tidal Streams Analysis Results					
Constituent	Period (hours)	Major Axis (cm sec ⁻¹)	Minor Axis (cm sec ⁻¹)	Inclination (degrees)	Phase Lag (degrees)
Mean	-	4.934	0.000	343.9	0.0
MSF	354.37	3.977	-2.889	95.1	309.0
O ₁	25.82	7.232	-0.602	134.8	331.3
K ₁	23.93	8.144	-3.191	126.0	26.5
M ₂	12.42	9.352	-1.761	134.8	300.3
S ₂	12.00	3.393	-0.294	96.0	327.3
2SM ₂	11.61	1.288	0.880	167.8	83.0
M ₃	8.28	2.031	-0.408	28.2	168.0
SK ₃	7.99	1.190	0.195	29.1	79.7
M ₄	6.21	2.383	-1.316	173.0	83.9
MS ₄	6.10	1.412	-0.320	78.5	130.5
S ₄	6.00	1.372	-0.067	50.3	226.8
2MNO ₅	4.97	1.494	-1.163	134.5	8.4
M ₆	4.14	0.821	0.361	142.8	306.5
2MS ₆	4.09	0.542	0.170	31.4	193.7
2SM ₆	4.04	0.194	-0.160	16.2	197.9
M ₈	3.10	0.247	0.021	136.0	243.2
3MS ₈	3.08	0.493	-0.262	175.6	192.6
M ₁₂	2.07	0.416	-0.067	95.5	85.5

Record 14M

17 April - 7 May, 1976

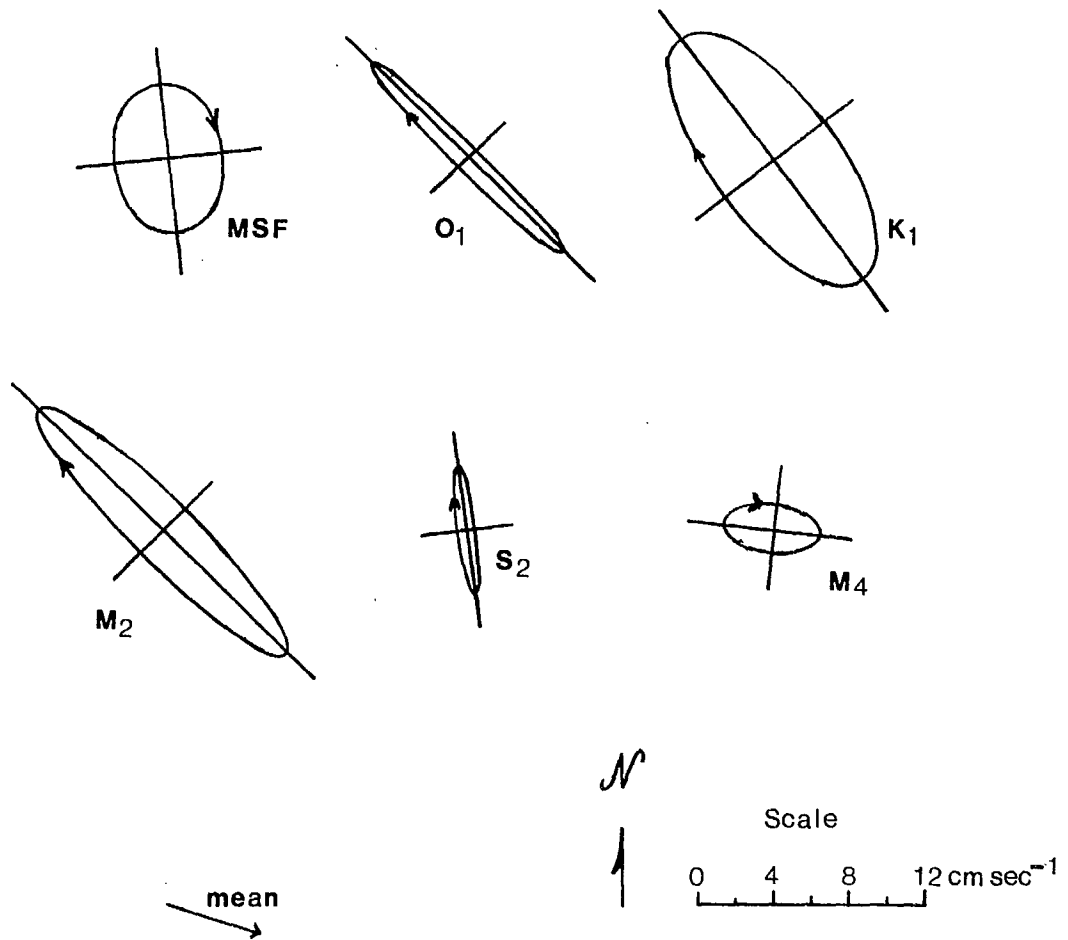

Figure 12: Tidal Ellipses - 14M.

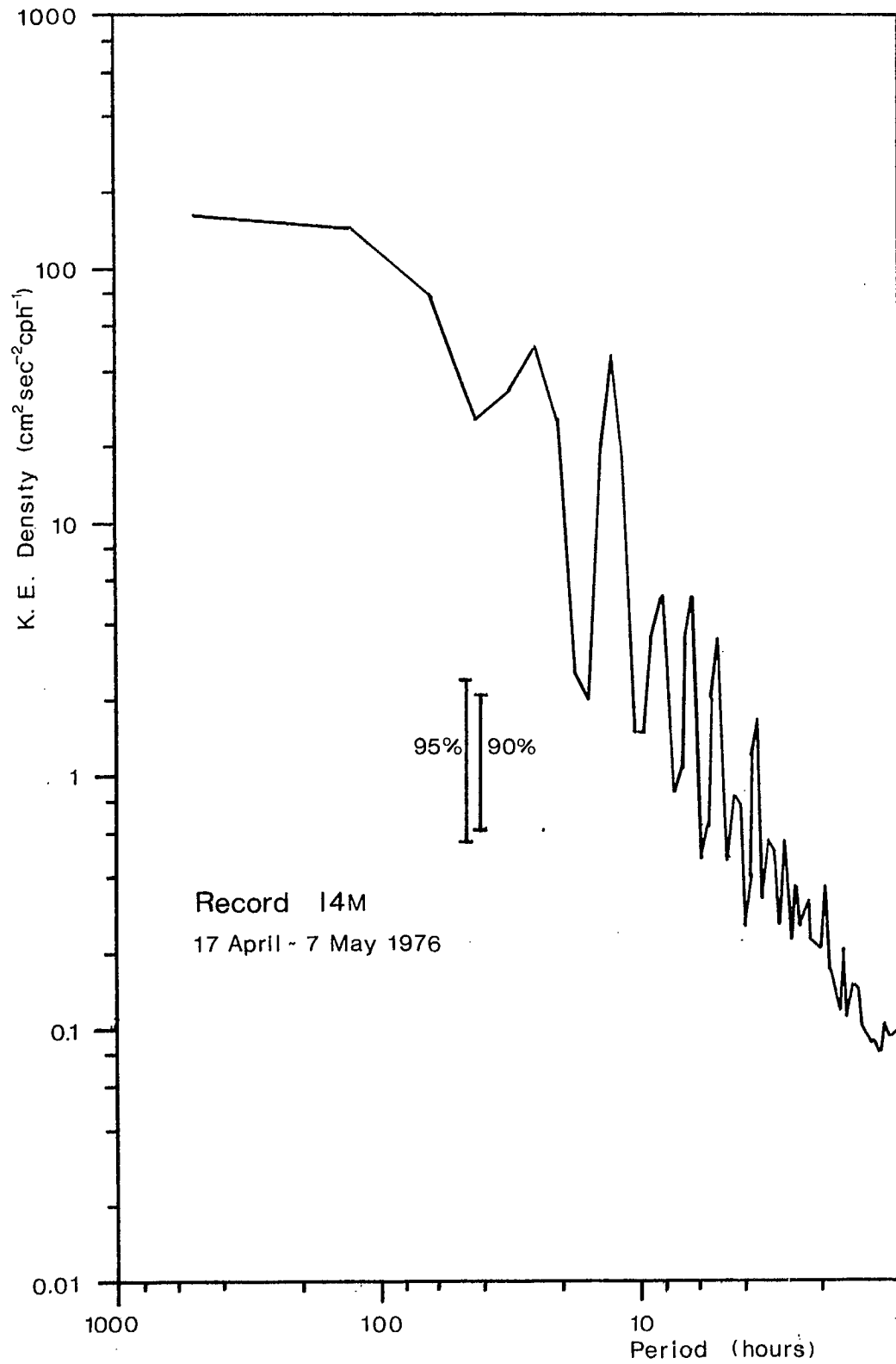
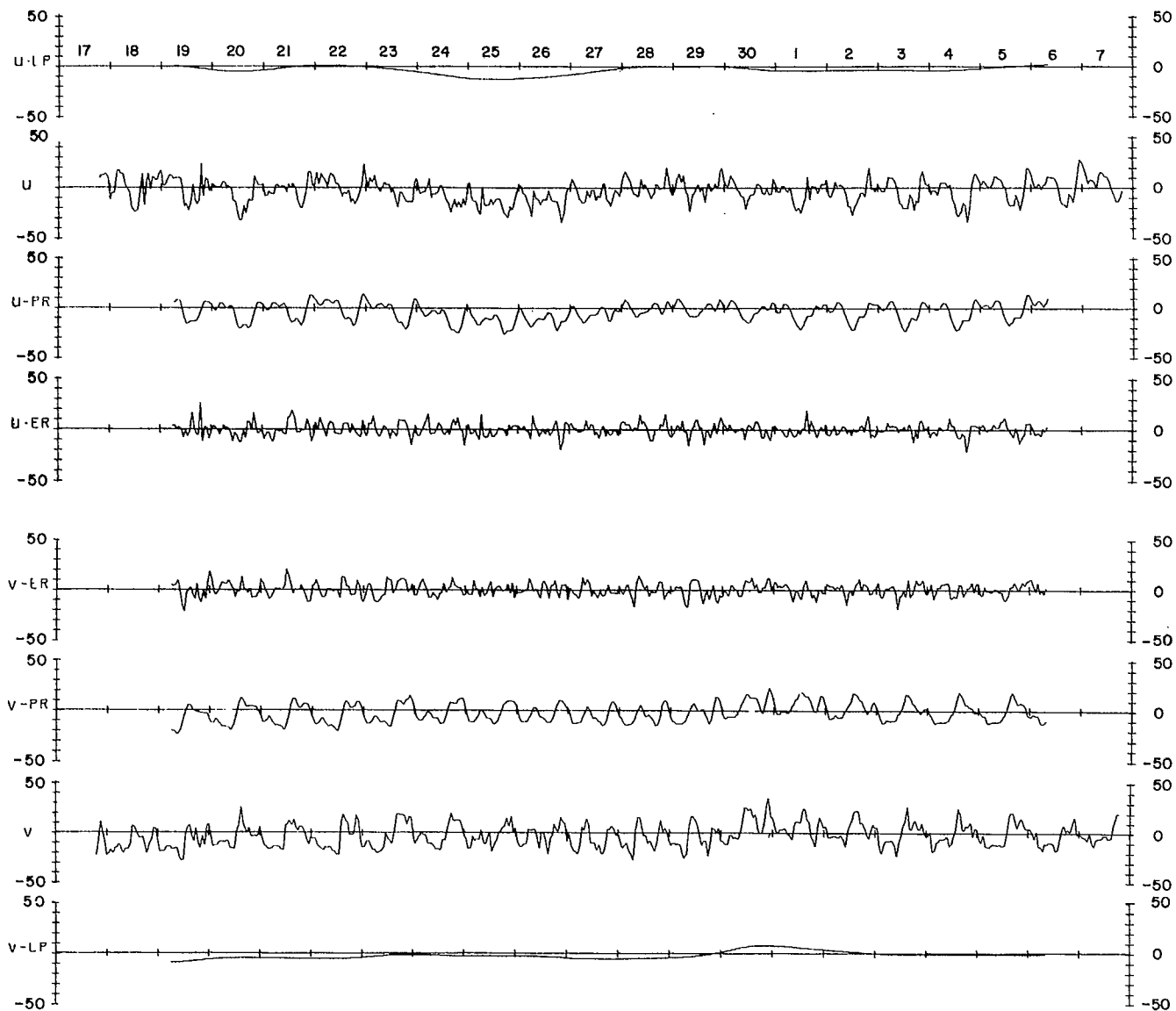

Figure 13: Power Spectrum - 14M.



STATION 14 E 17 APRIL - 7 MAY, 1976 Z = 3.4 M

Figure 14: Record 14E.

TABLE 6

Results of Tidal Streams Analysis - 14E

14E 17 April - 7 May, 1976 Tidal Streams Analysis Results					
Constituent	Period (hours)	Major Axis (cm sec ⁻¹)	Minor Axis (cm sec ⁻¹)	Inclination (degrees)	Phase Lag (degrees)
Mean	-	4.659	0.000	213.5	0.0
MSF	354.37	2.893	-1.636	177.9	302.8
O ₁	25.82	7.259	-2.015	135.1	323.0
K ₁	23.93	8.844	-5.183	126.4	25.2
M ₂	12.42	8.296	-2.262	134.7	309.3
S ₂	12.00	3.065	-1.078	65.7	305.6
2SM ₂	11.61	1.269	-0.300	30.0	275.1
M ₃	8.28	2.570	0.685	55.7	185.4
SK ₃	7.99	3.170	-0.645	53.6	77.9
M ₄	6.21	2.592	-1.648	56.0	215.0
MS ₄	6.10	0.784	0.243	23.1	150.0
S ₄	6.00	1.965	0.100	58.7	234.5
2MNO ₅	4.97	2.013	-1.604	172.3	319.2
M ₆	4.14	0.767	0.252	104.8	267.5
2MS ₆	4.09	0.582	-0.109	177.9	325.4
2SM ₆	4.04	0.454	-0.319	149.4	39.9
M ₈	3.10	0.290	0.129	146.4	271.7
3MS ₈	3.08	0.456	-0.321	126.8	221.8
M ₁₂	2.07	0.640	-0.048	91.6	73.1

Record 14E

17 April - 7 May, 1976

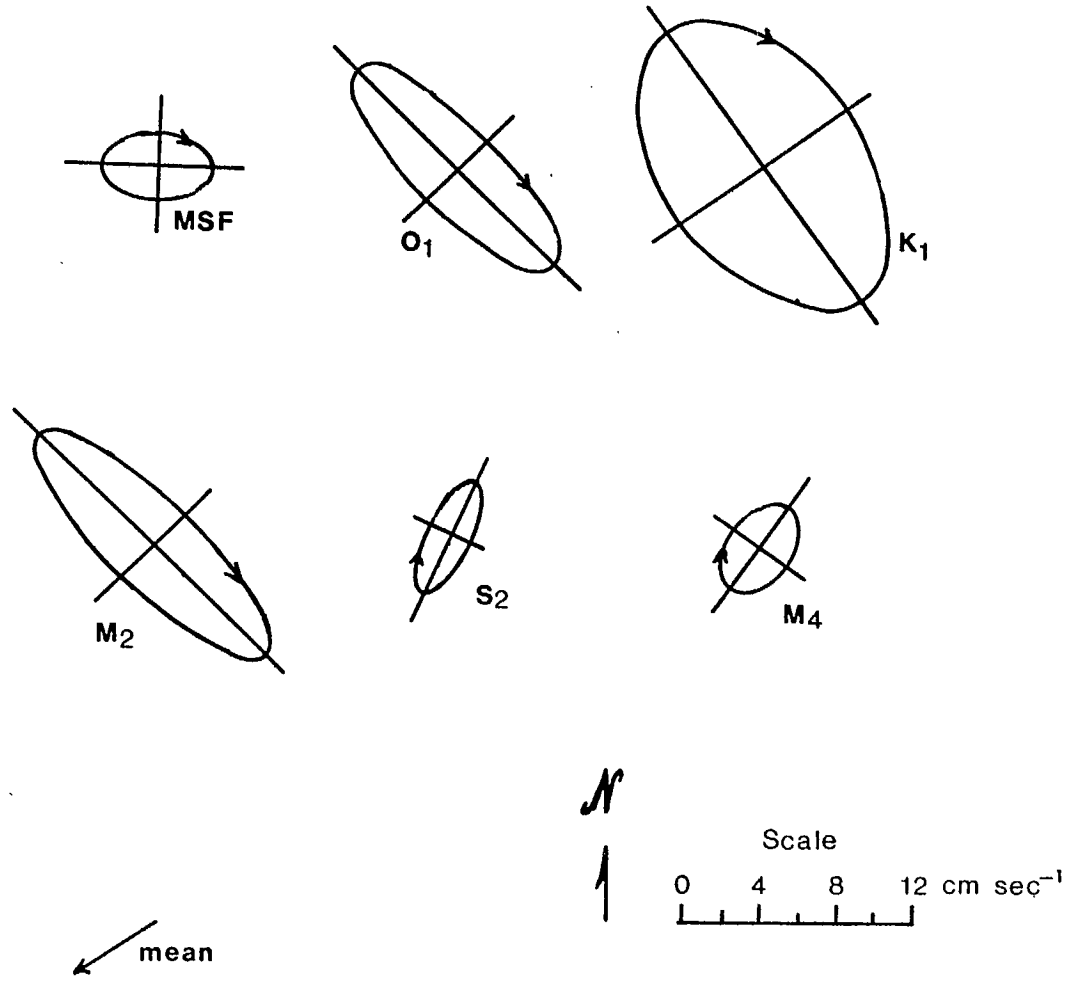

Figure 15: Tidal Ellipses - 14E.

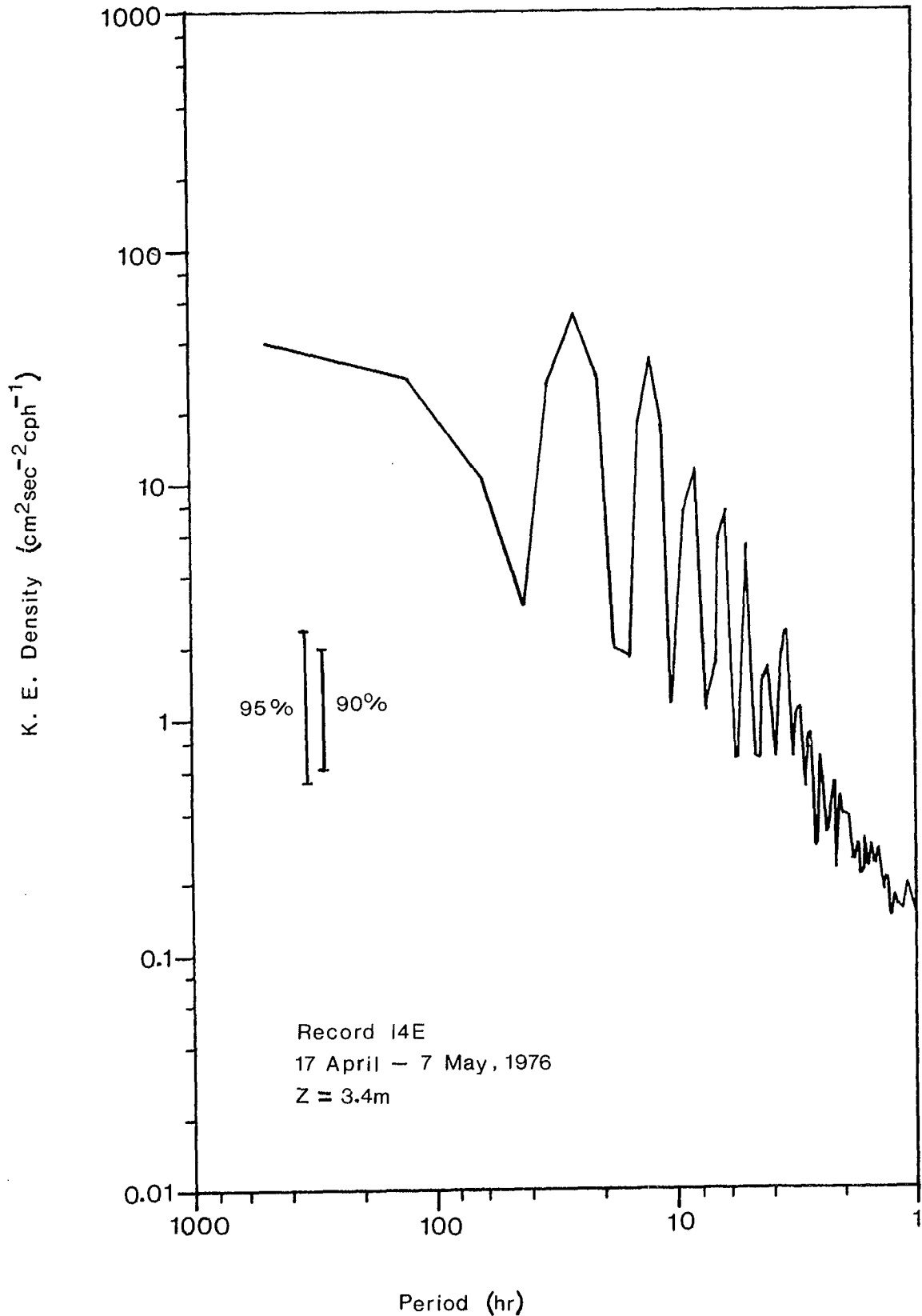

Figure 16: Power Spectrum - 14E.

SECTION III

TIDAL DATA

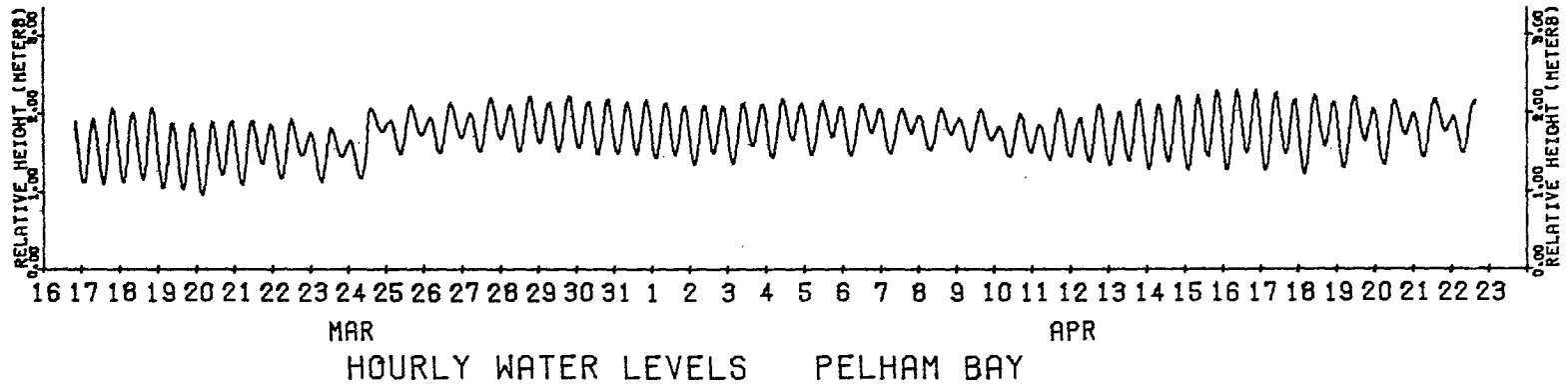

Figure 17: Pelham Bay Water Level Record.

TABLE 7

Tidal Analysis of Pelham Bay Tidal Record

Tidal Analysis: Pelham Bay Latitude: 76°45'N Time Zone: CST Longitude: 96°54'W CST			
Constituent	Number	Amplitude (meters)	Phase (degrees)
Z0	0	1.798	360.0
MM	10	0.045	147.2
MSF	61	0.024	165.0
SIG ₁	11	0.007	76.8
Q ₁	12	0.009	161.5
O ₁	1	0.069	243.3
NO ₁	17	0.021	259.4
K ₁	2	0.101	280.7
OQ ₂	30	0.008	73.5
MU ₂	15	0.018	352.6
N ₂	8	0.061	22.0
M ₂	3	0.275	39.7
S ₂	4	0.107	76.8
MSN ₂	43	0.004	282.1
2SM ₂	45	0.004	9.2
MO ₃	46	0.006	131.3
M ₃	37	0.006	125.5
MK ₃	48	0.001	229.8
SK ₃	49	0.002	134.8
MN ₄	18	0.002	6.9
M ₄	5	0.006	38.9
MS ₄	6	0.005	113.4
SK ₄	53	0.003	246.8
2MN ₆	54	0.000	127.3
M ₆	55	0.001	53.0
2MS ₆	57	0.001	126.7
2SM ₆	59	0.000	122.7
M ₈	19	0.000	14.8

TABLE 8

Luni-tidal Computations for Pelham Bay

Luni-tidal Computations: Pelham Bay								
Latitude		76° 45' N		Time Zone: CST				
Longitude		96° 54' W						
AGE M ₂ /S ₂	AGE K ₁ /O ₁		DL - SL	DL	SD	DL/SD	DL + SD	
37 2.57	37 1.46		243	0.12	0.30	0.41	0.42	
Mean Tide Times and Heights				Large Tide Ranges				
1413 2.2	115 2.1	2038 1.6	738 1.4	2.3	1.2	0.8	1.1	1.8
HHW	LHW	HLW	LLW	HHW	LLW	MT	LT	ZO

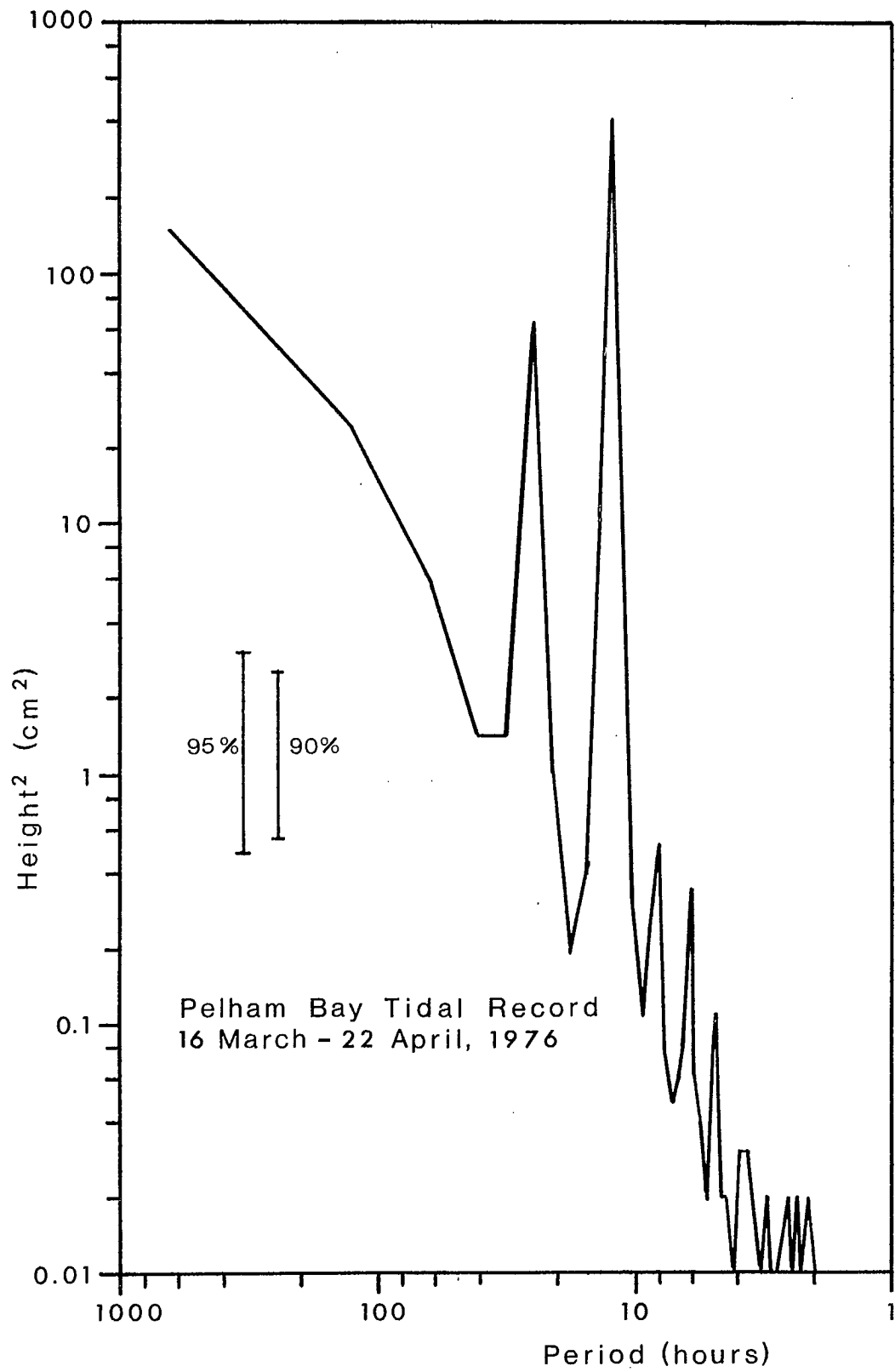

Figure 18: Height Spectrum - Pelham Bay Tidal Record.

SECTION IV

CTD RESULTS

PENNY STRAIT 1976 DATA PROFILES. TENT STATION 12 1 1

LAT 76 41.90 CSTD 803 WATER DEPTH 187.0

LONG 97 7.00 ICE 0.8 TIME (G.M.T.) 1730

DATE 13 4 1976

DEPTH	SAL	TEMP	SIGMAT	SOUND
2.0	31.34	-1.79	25.23	1435.8
5.0	31.34	-1.79	25.23	1435.9
10.0	31.34	-1.79	25.23	1436.0
15.0	31.34	-1.79	25.23	1436.1
20.0	31.34	-1.79	25.23	1436.1
25.0	31.37	-1.77	25.25	1436.4
30.0	31.43	-1.77	25.30	1436.5
35.0	31.52	-1.74	25.38	1436.9
40.0	31.62	-1.68	25.46	1437.4
45.0	31.70	-1.59	25.52	1438.0
50.0	31.82	-1.55	25.59	1438.5
60.0	31.88	-1.44	25.66	1439.2
70.0	31.95	-1.39	25.72	1439.9
80.0	32.42	-0.99	26.09	1442.6
90.0	32.48	-0.99	26.13	1442.8
100.0	32.57	-0.93	26.21	1443.4
128.0	32.68	-0.82	26.29	1444.5
155.0	32.68	-0.82	26.29	1444.5

PENNY STRAIT 1976 DATA PROFILES. TENT STATION 12 2 2

LAT 76 41.90 CSTD 803 WATER DEPTH 187.0

LONG 97 7.00 ICE 0.8 TIME (G.M.T.) 1830

DATE 13 4 1976

DEPTH	SAL	TEMP	SIGMAT	SOUND
2.0	31.40	-1.79	25.28	1435.9
5.0	31.45	-1.79	25.32	1436.1
10.0	31.49	-1.77	25.35	1436.3
15.0	31.55	-1.77	25.40	1436.4
20.0	31.69	-1.63	25.51	1437.4
25.0	31.73	-1.57	25.55	1437.8
30.0	31.73	-1.57	25.55	1437.9
35.0	31.80	-1.52	25.60	1438.3
40.0	31.87	-1.48	25.65	1438.7
45.0	31.91	-1.39	25.71	1439.3
50.0	31.98	-1.37	25.74	1439.3
60.0	32.11	-1.28	25.84	1440.3
70.0	32.17	-1.17	25.89	1441.1
80.0	32.31	-1.10	26.00	1441.8
90.0	32.44	-1.02	26.11	1442.5
100.0	32.45	-0.97	26.11	1442.5
128.0	32.64	-0.84	26.26	1444.2
155.0	32.78	-0.71	26.37	1445.5

PENNY STRAIT

STATION 12 1 1

1730 GMT 13 4 1976 ICE= 0.8

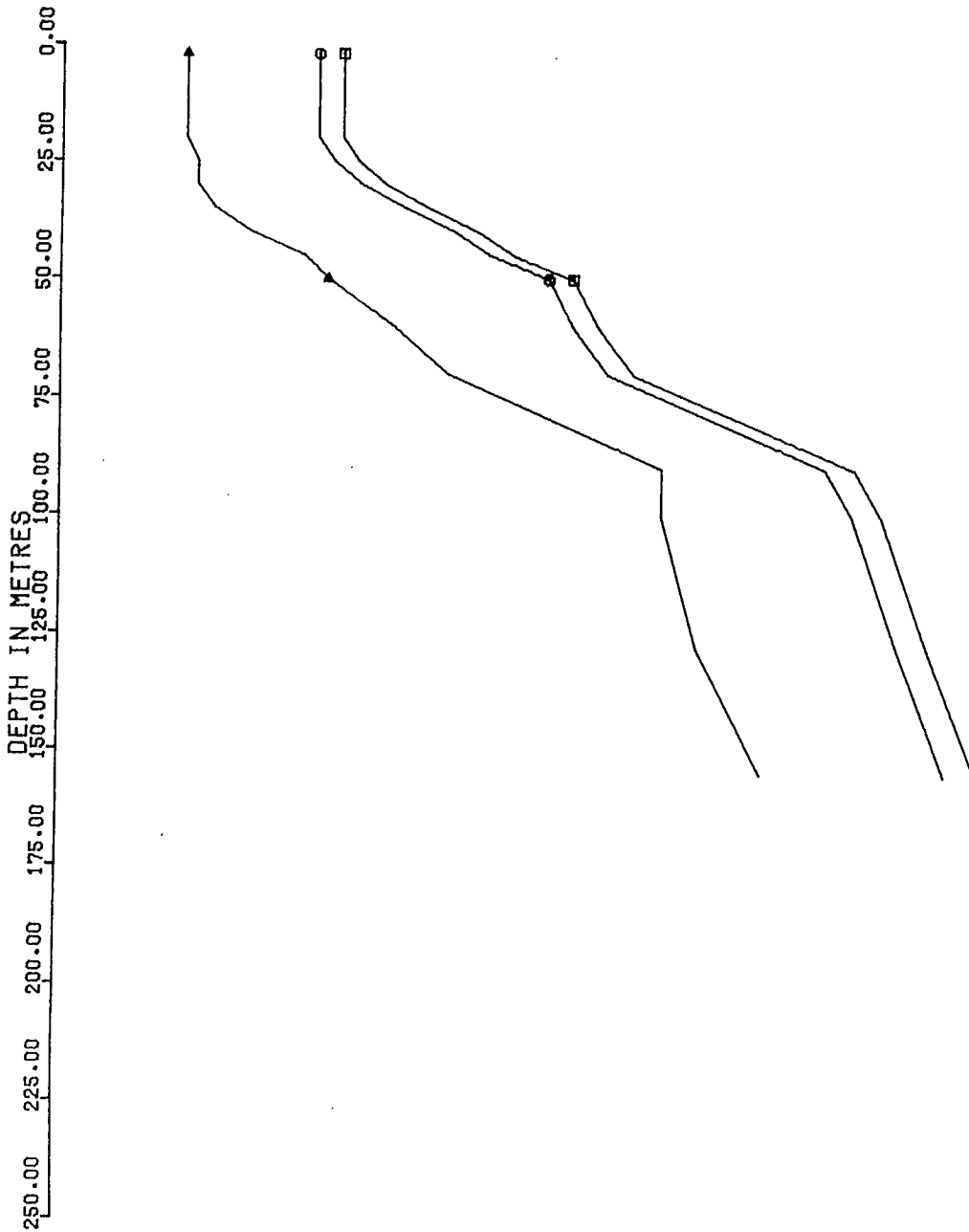
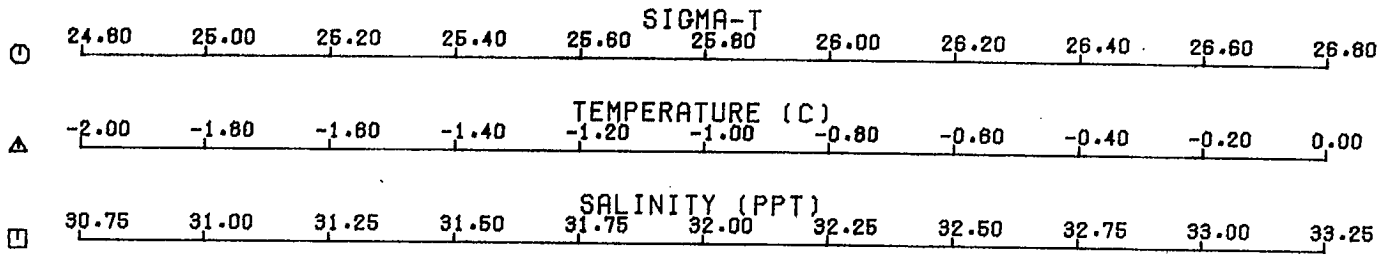

PENNY STRAIT

STATION 12 2 2

1830 GMT 13 4 1976 ICE= 0.8

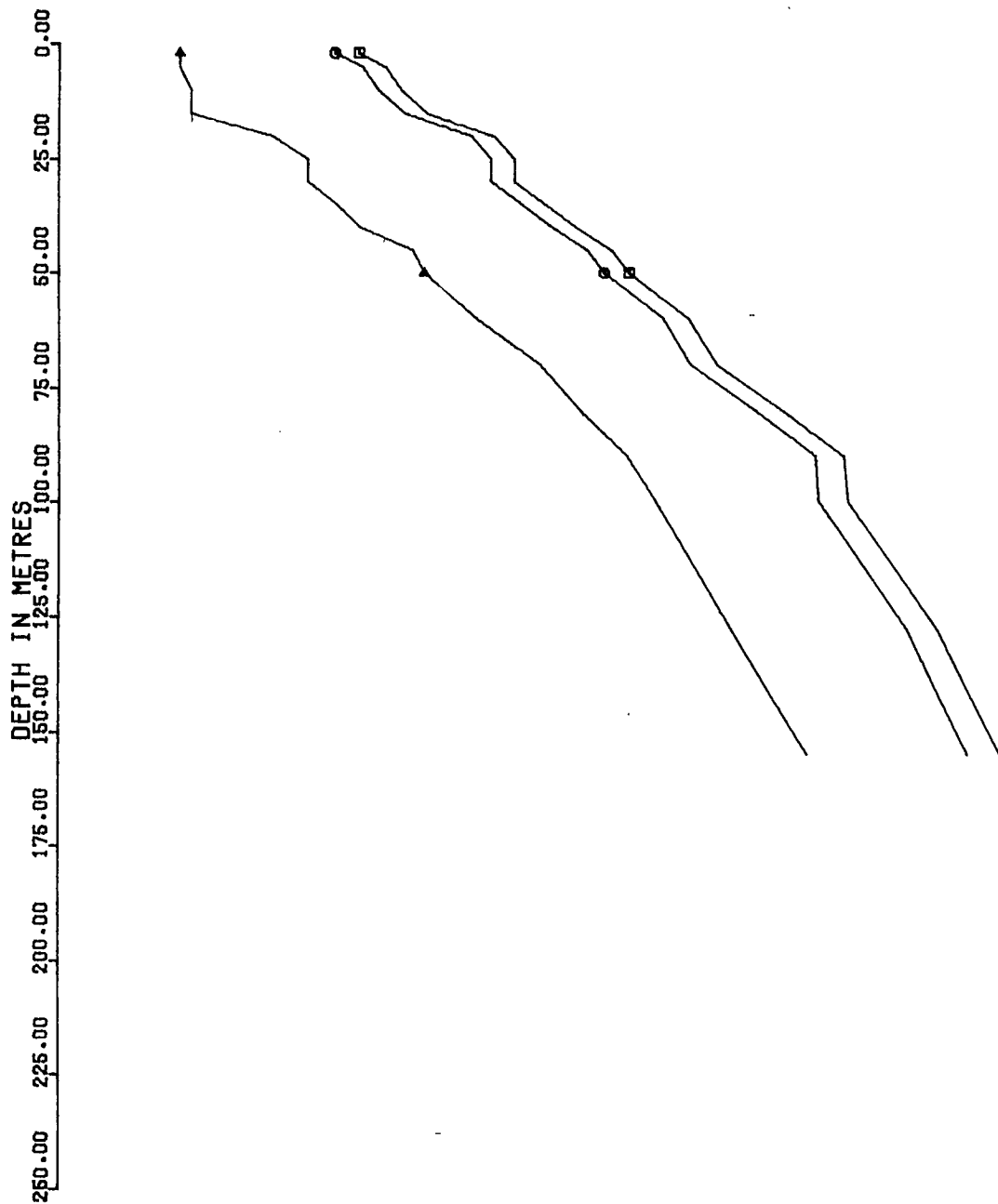
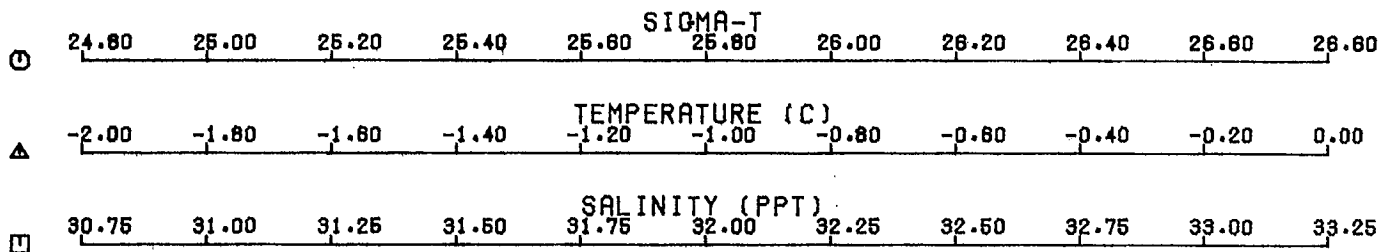

PENNY STRAIT 1976 DATA PROFILES. TENT STATION 12 3 3
 LAT 76 41.50 OSTD 803 WATER DEPTH 187.0
 LONG 97 7.00 ICE 0.8 TIME (G.M.T.) 1930
 DATE 13 4 1976

DEPTH	SAL	TEMP	SIGMAT	SOUND
2.0	31.42	-1.81	25.30	1435.9
5.0	31.44	-1.79	25.31	1436.0
10.0	31.44	-1.79	25.32	1436.1
15.0	31.44	-1.79	25.32	1436.2
20.0	31.49	-1.77	25.35	1436.4
25.0	31.49	-1.77	25.35	1436.5
30.0	31.55	-1.77	25.40	1436.7
35.0	31.58	-1.75	25.42	1436.9
40.0	31.51	-1.72	25.45	1437.2
45.0	31.68	-1.68	25.50	1437.6
50.0	31.76	-1.59	25.57	1438.2
60.0	31.91	-1.41	25.68	1439.4
70.0	32.01	-1.35	25.76	1440.0
80.0	32.31	-1.10	25.90	1441.8
90.0	32.44	-1.02	26.11	1442.5
100.0	32.52	-0.93	26.16	1443.2
128.0	32.68	-0.82	26.29	1444.4
155.0	32.77	-0.75	26.36	1445.3

PENNY STRAIT 1976 DATA PROFILES. TENT STATION 12 4 4
 LAT 76 41.50 OSTD 803 WATER DEPTH 187.0
 LONG 97 7.00 ICE 0.8 TIME (G.M.T.) 2030
 DATE 13 4 1976

DEPTH	SAL	TEMP	SIGMAT	SOUND
2.0	31.36	-1.81	25.25	1435.8
5.0	31.40	-1.79	25.26	1435.0
10.0	31.40	-1.79	25.28	1436.1
15.0	31.45	-1.79	25.32	1436.2
20.0	31.49	-1.77	25.35	1436.4
25.0	31.58	-1.74	25.42	1436.8
30.0	31.62	-1.72	25.46	1437.0
40.0	31.87	-1.48	25.65	1438.7
45.0	31.90	-1.45	25.68	1438.9
50.0	31.93	-1.44	25.70	1439.1
60.0	31.94	-1.39	25.71	1439.5
70.0	31.98	-1.37	25.74	1439.8
80.0	32.01	-1.35	25.76	1440.1
90.0	32.01	-1.35	25.76	1440.3
105.0	32.18	-1.19	25.90	1441.6
133.0	32.67	-0.86	26.28	1444.2
155.0	32.80	-0.73	26.39	1445.4

PENNY STRAIT

STATION 12 3 3

1930 GMT 13 4 1976 ICE= 0.8

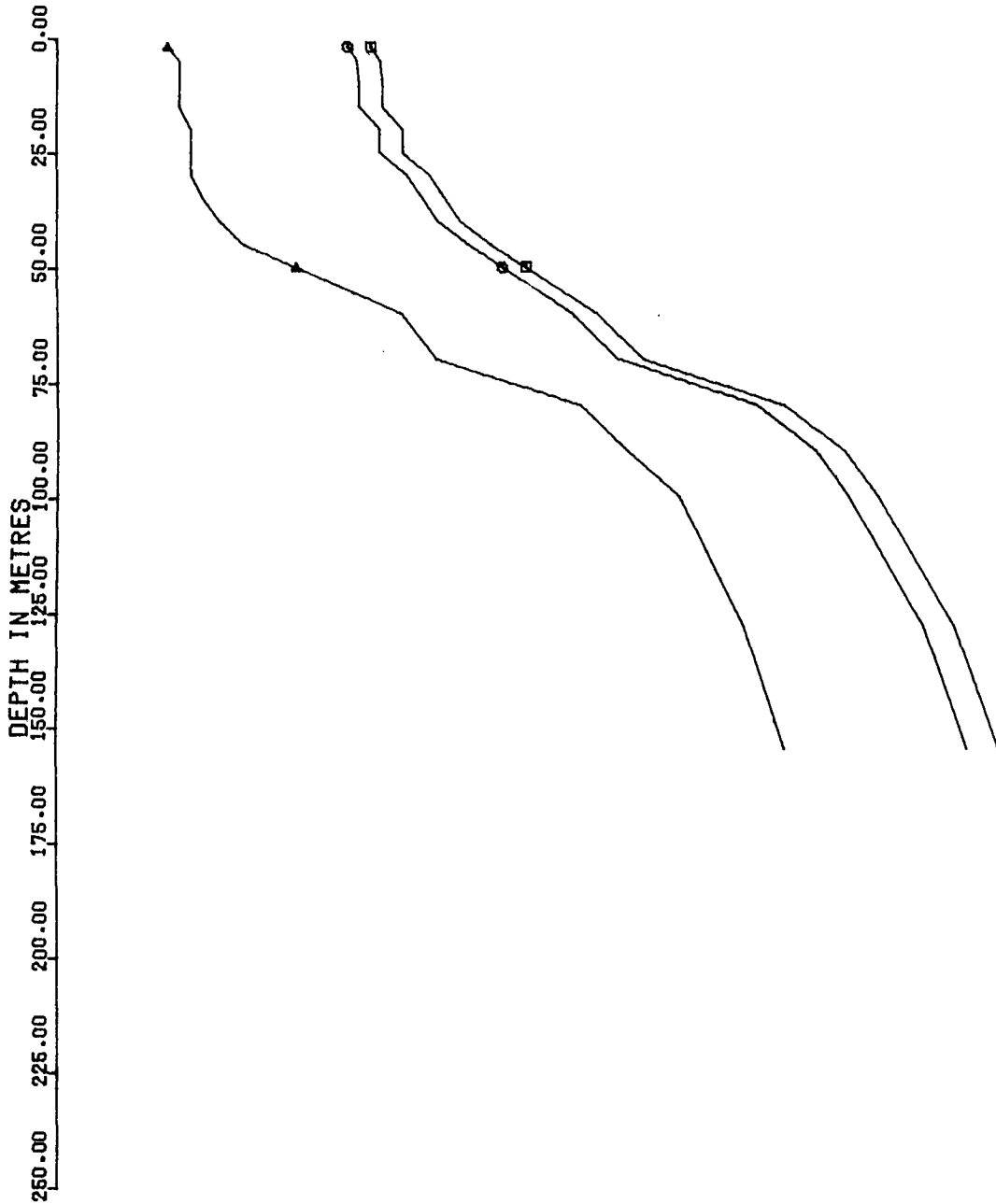
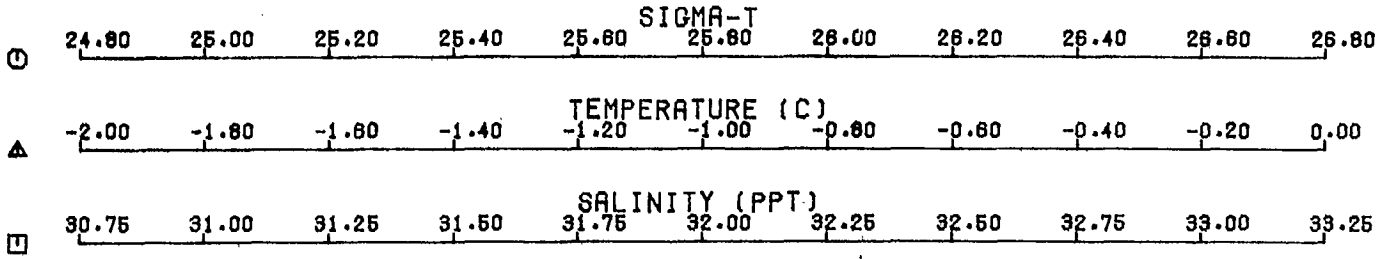

PENNY STRAIT

STATION 12 4 4

2030 GMT 13 4 1976 ICE= 0.8

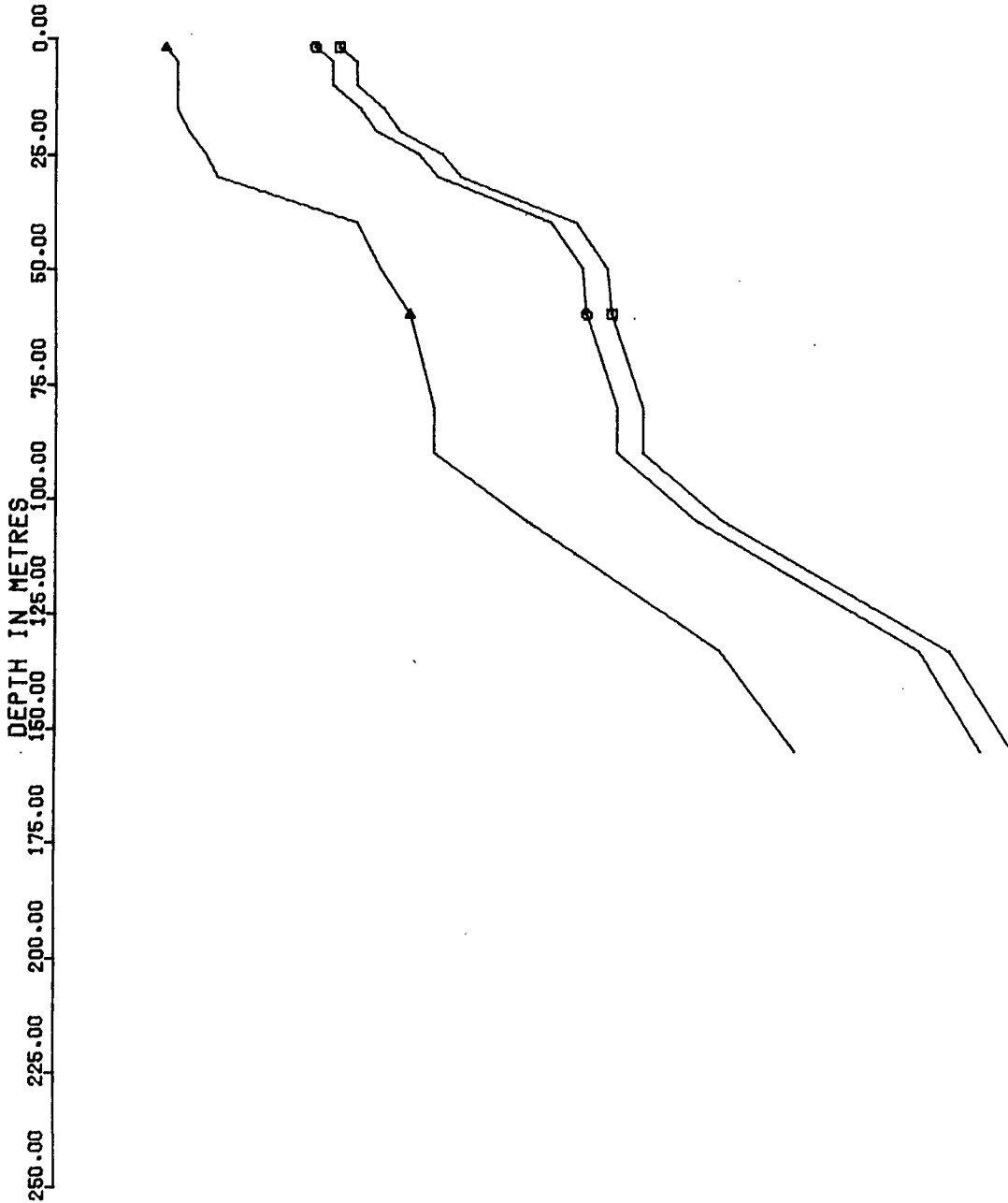
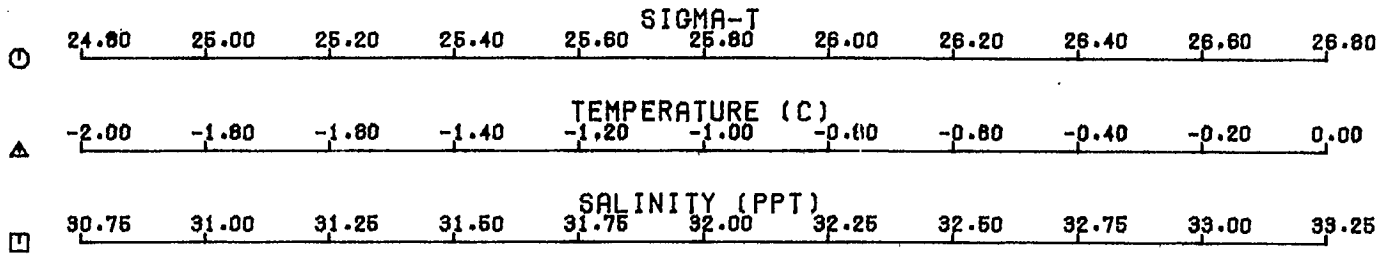

PENNY STRAIT 1976 DATA PROFILES. TENT STATION 12 5 5

LAT 76 41.50 CSTD 803 WATER DEPTH 187.0

LONG 97 7.00 ICE 0.8 TIME (G.M.T.) 2140

DATE 13 4 1976

DEPTH	SAL	TEMP	SIGMAT	SOUND
2.0	31.76	-1.81	25.25	1435.8
5.0	31.40	-1.79	25.28	1436.0
10.0	31.40	-1.79	25.28	1436.1
15.0	31.45	-1.79	25.32	1436.2
20.0	31.45	-1.79	25.32	1436.3
25.0	31.49	-1.77	25.35	1436.5
30.0	31.55	-1.77	25.40	1436.7
40.0	31.55	-1.77	25.40	1436.9
45.0	31.56	-1.72	25.40	1437.2
50.0	31.61	-1.61	25.45	1437.4
55.0	31.95	-1.50	25.72	1438.2
60.0	32.11	-1.28	25.84	1440.3
70.0	32.12	-1.24	25.85	1440.7
80.0	32.16	-1.17	25.88	1441.2
90.0	32.16	-1.17	25.88	1441.4
100.0	32.41	-1.08	25.08	1442.3
120.0	32.44	-1.02	25.11	1443.1
155.0	32.64	-0.88	26.26	1444.5

PENNY STRAIT 1976 DATA PROFILES. TENT STATION 12 6 6

LAT 76 41.80 CSTD 803 WATER DEPTH 167.0

LONG 97 7.00 ICE 0.8 TIME (G.M.T.) 2240

DATE 13 4 1976

DEPTH	SAL	TEMP	SIGMAT	SOUND
2.0	31.42	-1.81	25.30	1435.9
5.0	31.45	-1.79	25.32	1436.1
10.0	31.45	-1.79	25.32	1436.1
15.0	31.52	-1.74	25.39	1436.6
20.0	31.62	-1.68	25.46	1437.1
25.0	31.66	-1.66	25.49	1437.3
30.0	31.69	-1.63	25.51	1437.6
35.0	31.79	-1.57	25.59	1438.1
40.0	31.86	-1.50	25.67	1438.6
50.0	31.93	-1.48	25.70	1438.9
60.0	32.00	-1.39	25.76	1439.6
70.0	32.16	-1.17	25.88	1441.0
80.0	32.35	-1.08	26.03	1441.9
90.0	32.38	-1.06	26.05	1442.2
100.0	32.48	-0.99	26.13	1442.9
135.0	32.60	-0.90	26.23	1444.0
155.0	32.70	-0.84	26.31	1444.7

PENNY STRAIT

STATION 12 5 5

2140 GMT 13 4 1976 ICE= 0.8

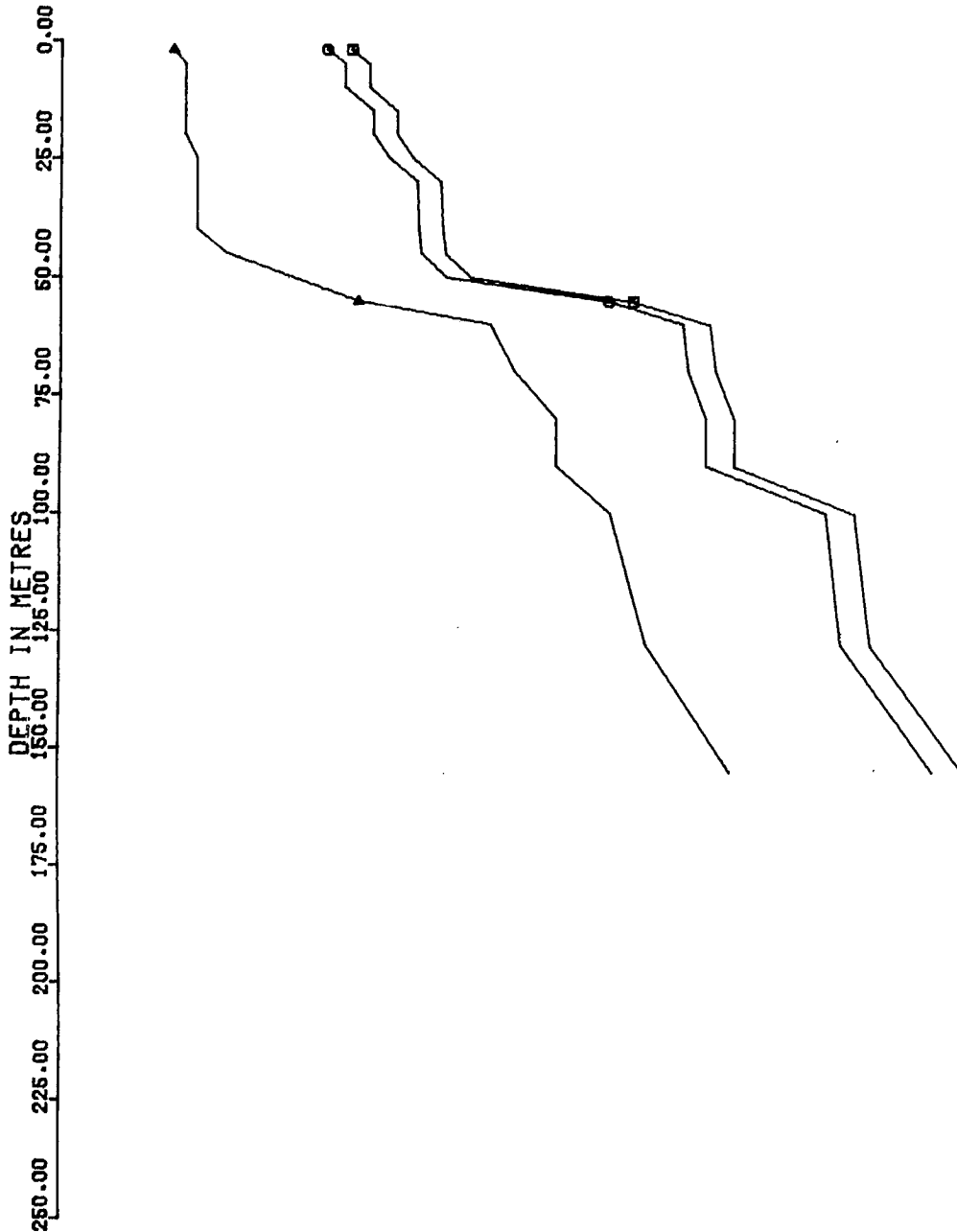
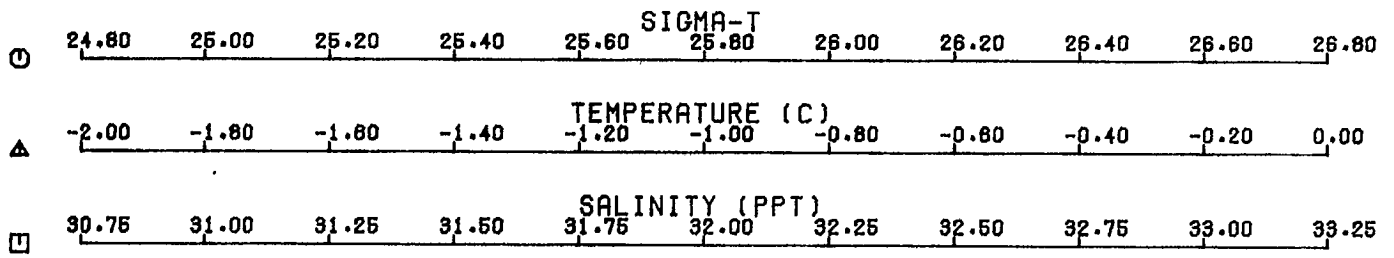

PENNY STRAIT

STATION 12 6 6

2240 GMT 13 4 1976 ICE= 0.8

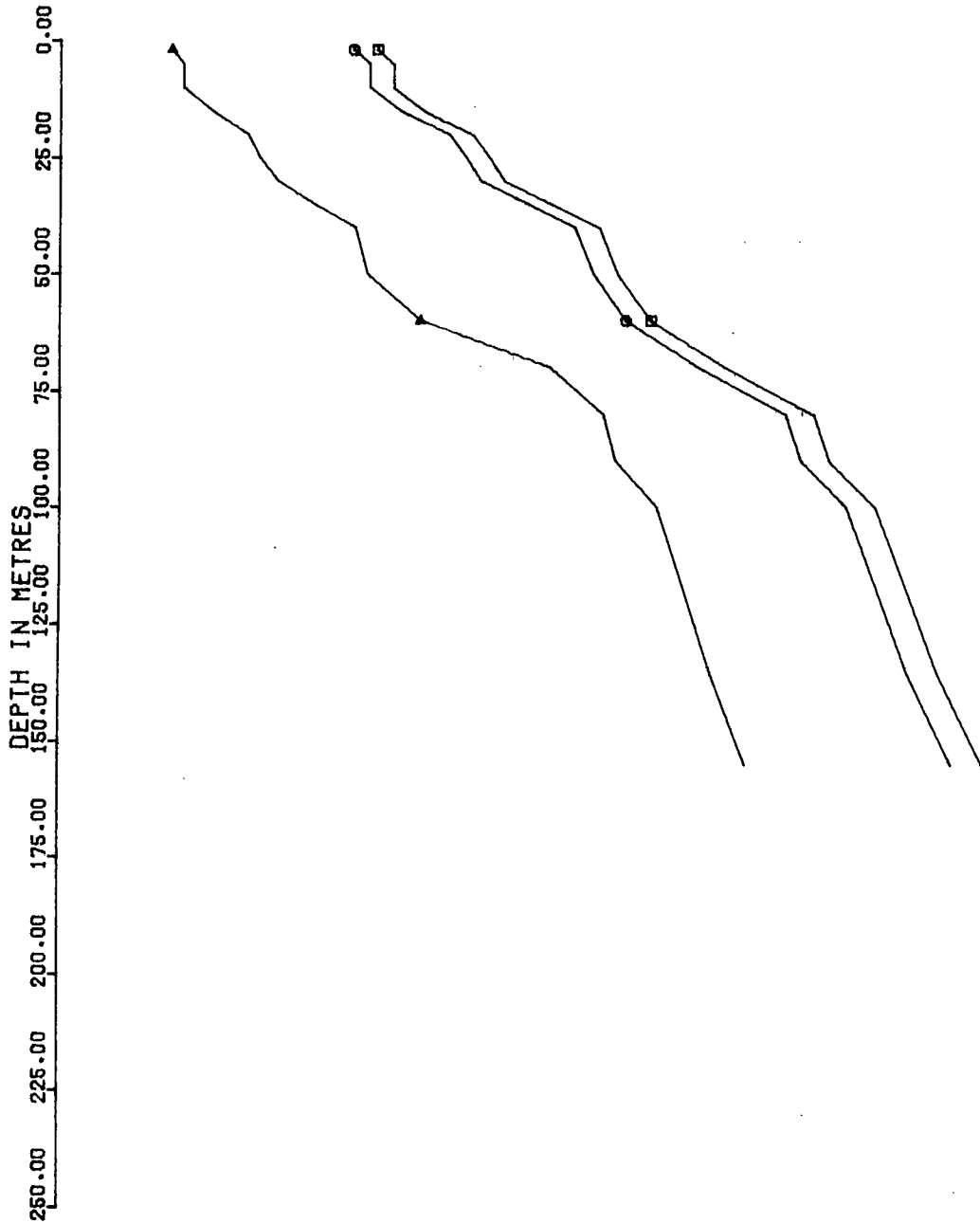
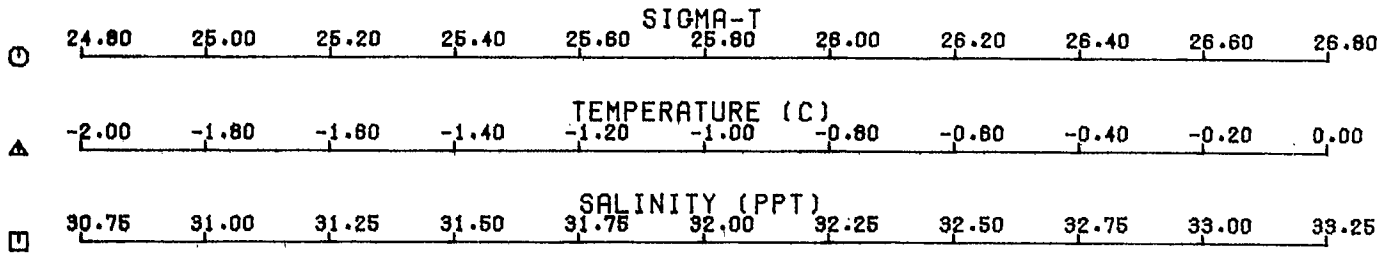

PENNY STRAIT 1976 DATA PROFILES. TENT STATION 12 7 7

LAT 76 41.90 CSTD 803 WATER DEPTH 187.0

LONG 97 7.00 ICE 0.8 TIME (G.M.T.) 2330

DATE 13 4 1976

DEPTH	SAL	TEMP	SIGMAT	SOUND
2.0	31.42	-1.81	25.30	1435.9
5.0	31.42	-1.81	25.30	1435.9
10.0	31.45	-1.79	25.32	1436.1
15.0	31.45	-1.79	25.32	1436.1
20.0	31.52	-1.74	25.38	1436.6
25.0	31.53	-1.70	25.38	1436.6
30.0	31.53	-1.70	25.39	1437.0
35.0	31.61	-1.61	25.45	1437.6
40.0	31.70	-1.59	25.52	1437.9
45.0	31.76	-1.59	25.57	1438.1
50.0	31.81	-1.59	25.61	1438.3
55.0	31.93	-1.46	25.70	1439.2
60.0	31.93	-1.44	25.70	1439.4
70.0	32.01	-1.35	25.76	1440.1
80.0	32.43	-1.10	26.09	1442.1
90.0	32.44	-1.02	26.11	1442.5
100.0	32.74	-0.77	26.34	1444.7
128.0	32.84	-0.71	26.41	1445.5
155.0				

PENNY STRAIT 1976 DATA PROFILES. TENT STATION 12 8 8

LAT 76 41.50 CSTD 803 WATER DEPTH 187.0

LONG 97 7.00 ICE 0.8 TIME (G.M.T.) 0031

DATE 14 4 1976

DEPTH	SAL	TEMP	SIGMAT	SOUND
2.0	31.42	-1.81	25.30	1435.9
5.0	31.42	-1.81	25.30	1435.9
10.0	31.42	-1.81	25.30	1436.0
20.0	31.43	-1.77	25.30	1436.4
25.0	31.43	-1.77	25.30	1436.4
30.0	31.44	-1.72	25.31	1436.8
35.0	31.47	-1.70	25.34	1437.0
40.0	31.60	-1.66	25.44	1437.5
45.0	31.77	-1.55	25.57	1438.3
50.0	31.83	-1.50	25.63	1438.7
55.0	31.90	-1.46	25.68	1439.2
60.0	31.94	-1.39	25.71	1439.7
70.0	32.01	-1.35	25.76	1440.1
80.0	32.13	-1.19	25.85	1441.2
90.0	32.34	-1.13	26.02	1442.0
100.0	32.60	-0.99	26.23	1443.9
128.0	32.84	-0.66	26.42	1445.8
155.0				

PENNY STRAIT

STATION 12 7 7

2330 GMT 13 4 1976 ICE= 0.8

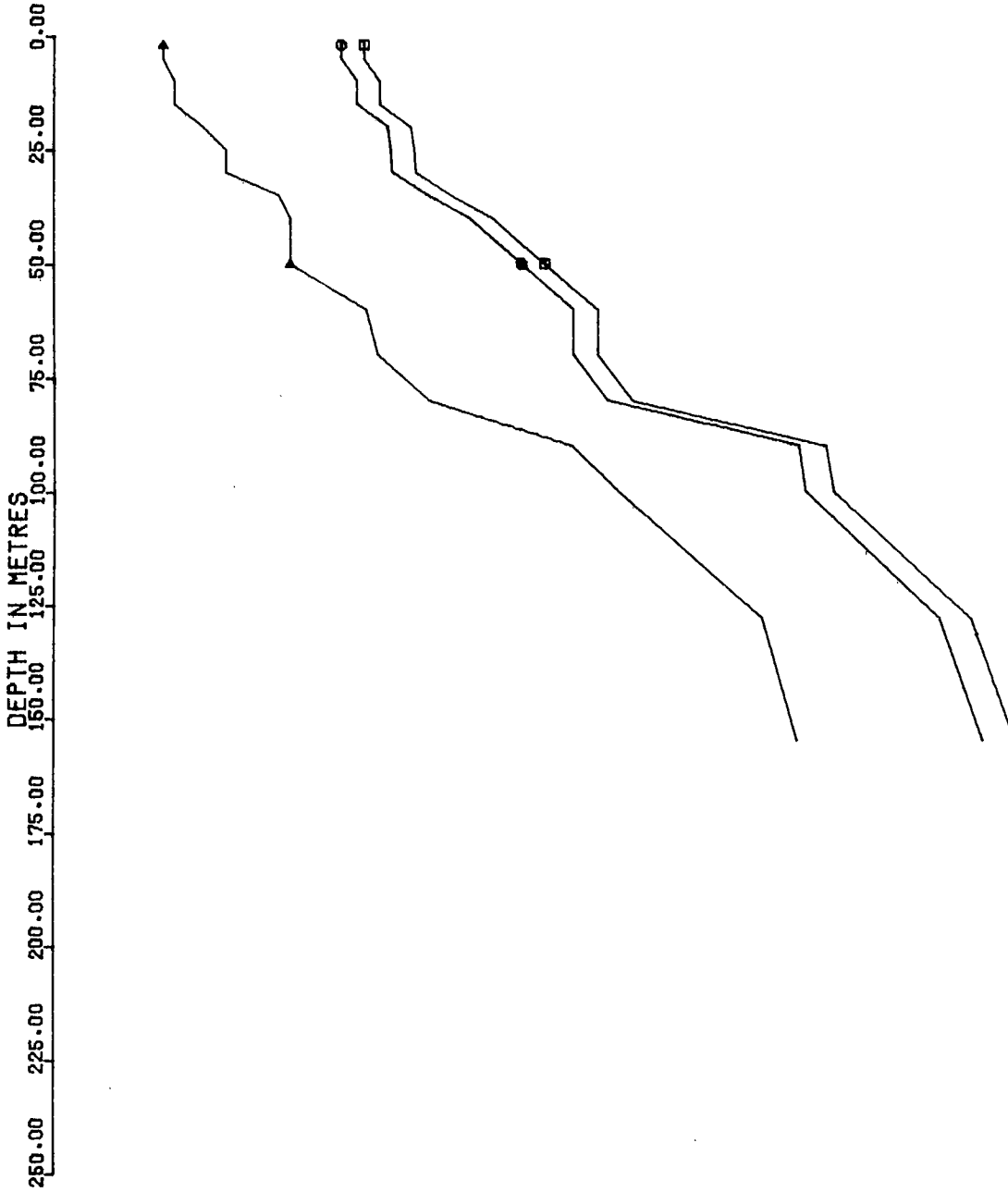
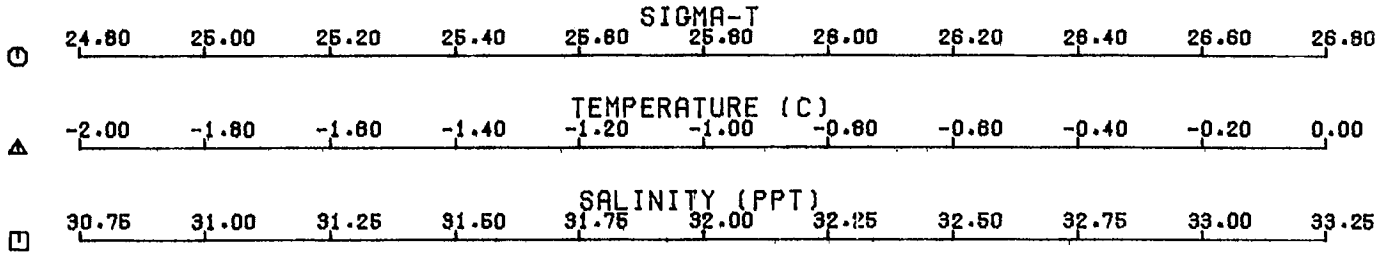

PENNY STRAIT

STATION 12 8 8

0034 GMT 14 4 1976 ICE= 0.8

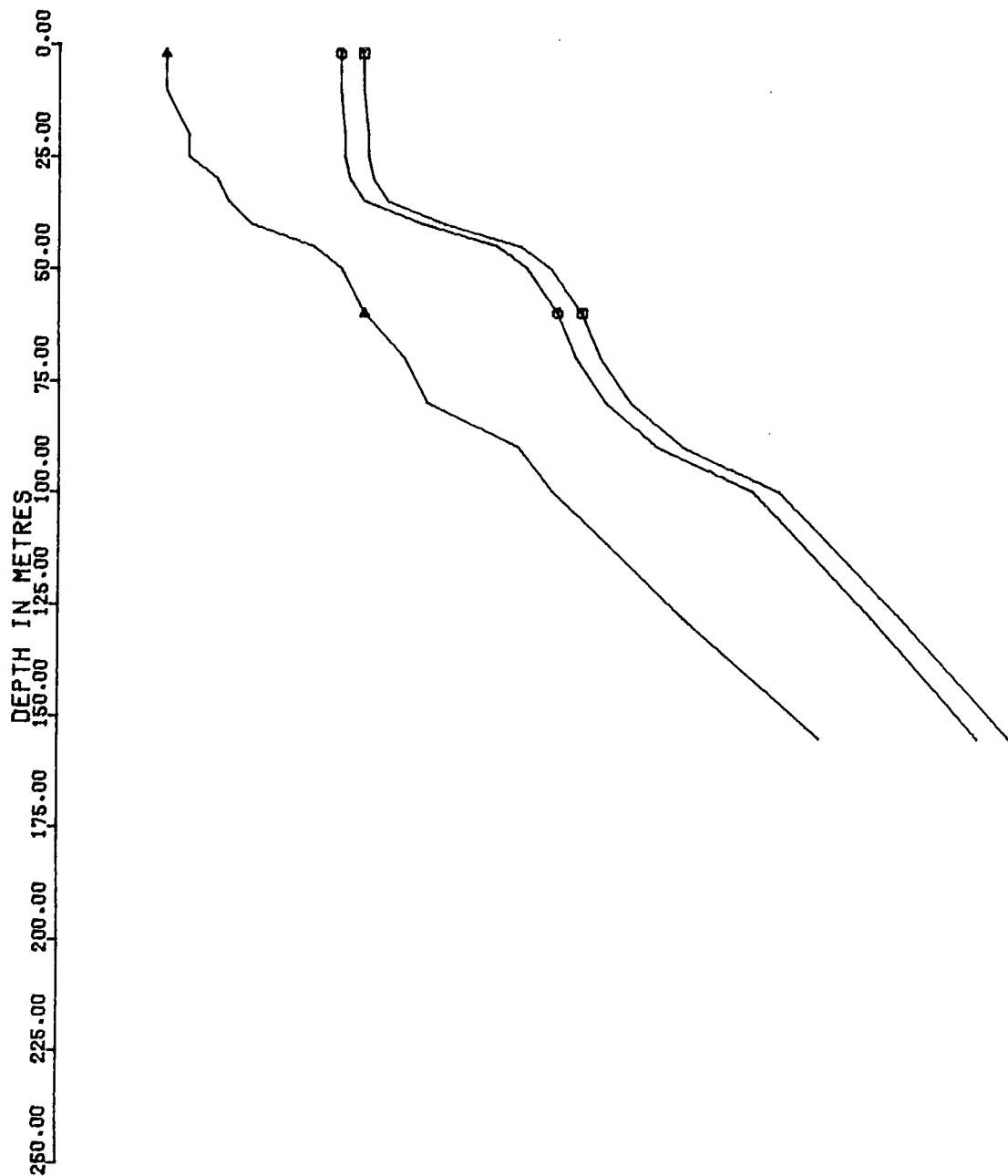
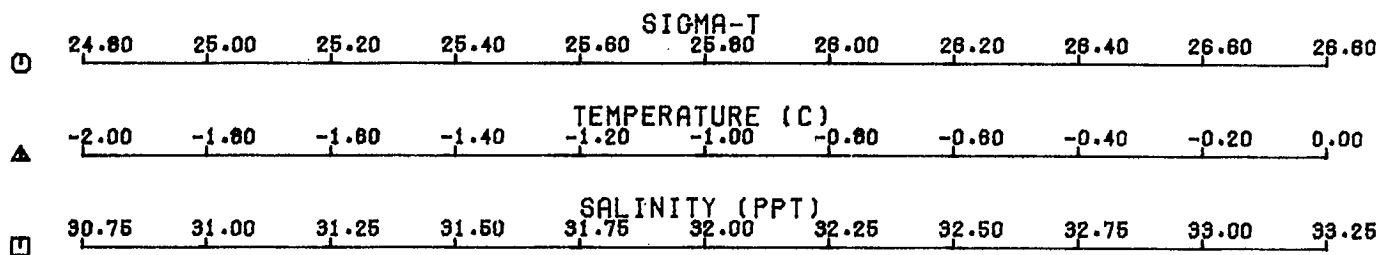

PENNY STRAIT 1976 DATA PROFILES. TENT STATION 12 9 9
 LAT 76 41.50 OSTD 803 WATER DEPTH 187.0
 LONG 97 7.00 ICE 0.8 TIME (G.M.T.) 0134
 DATE 14 4 1976

DEPTH	SAL	TEMP	SIGMAT	SOUND
2.0	31.36	-1.81	25.25	1435.8
5.0	31.36	-1.81	25.25	1435.8
10.0	31.40	-1.79	25.28	1436.1
15.0	31.40	-1.79	25.28	1436.1
20.0	31.40	-1.79	25.26	1436.2
25.0	31.43	-1.77	25.30	1436.4
30.0	31.43	-1.77	25.30	1436.5
35.0	31.47	-1.68	25.41	1437.2
40.0	31.46	-1.66	25.49	1437.5
45.0	31.70	-1.64	25.52	1437.8
50.0	31.87	-1.59	25.56	1438.3
55.0	31.92	-1.48	25.70	1439.1
70.0	31.94	-1.39	25.71	1439.7
80.0	31.98	-1.37	25.74	1440.0
90.0	31.98	-1.32	25.74	1440.4
100.0	32.11	-1.28	25.84	1440.9
110.0	32.19	-1.15	25.91	1441.8
125.0	32.50	-1.02	26.15	1443.2
155.0	32.71	-0.79	26.31	1445.0

PENNY STRAIT 1976 DATA PROFILES. TENT STATION 12 10 10
 LAT 76 41.50 OSTD 803 WATER DEPTH 187.0
 LONG 97 7.00 ICE 0.8 TIME (G.M.T.) 0230
 DATE 14 4 1976

DEPTH	SAL	TEMP	SIGMAT	SOUND
2.0	31.42	-1.81	25.30	1435.9
5.0	31.42	-1.81	25.30	1435.9
10.0	31.46	-1.79	25.33	1436.1
15.0	31.46	-1.79	25.33	1436.2
20.0	31.46	-1.79	25.33	1436.3
25.0	31.46	-1.79	25.33	1436.4
30.0	31.49	-1.77	25.35	1436.6
35.0	31.49	-1.77	25.35	1436.7
40.0	31.52	-1.74	25.39	1437.0
45.0	31.56	-1.72	25.40	1437.2
50.0	31.59	-1.70	25.43	1437.4
55.0	31.63	-1.63	25.46	1437.7
60.0	31.63	-1.63	25.55	1438.3
70.0	31.79	-1.57	25.59	1438.8
80.0	31.91	-1.41	25.68	1439.9
90.0	31.98	-1.37	25.74	1440.3
100.0	32.43	-1.10	26.09	1442.7
125.0	32.54	-0.95	26.18	1444.0

PENNY STRAIT

STATION 12 9 9

0134 GMT 14 4 1976 ICE= 0.8

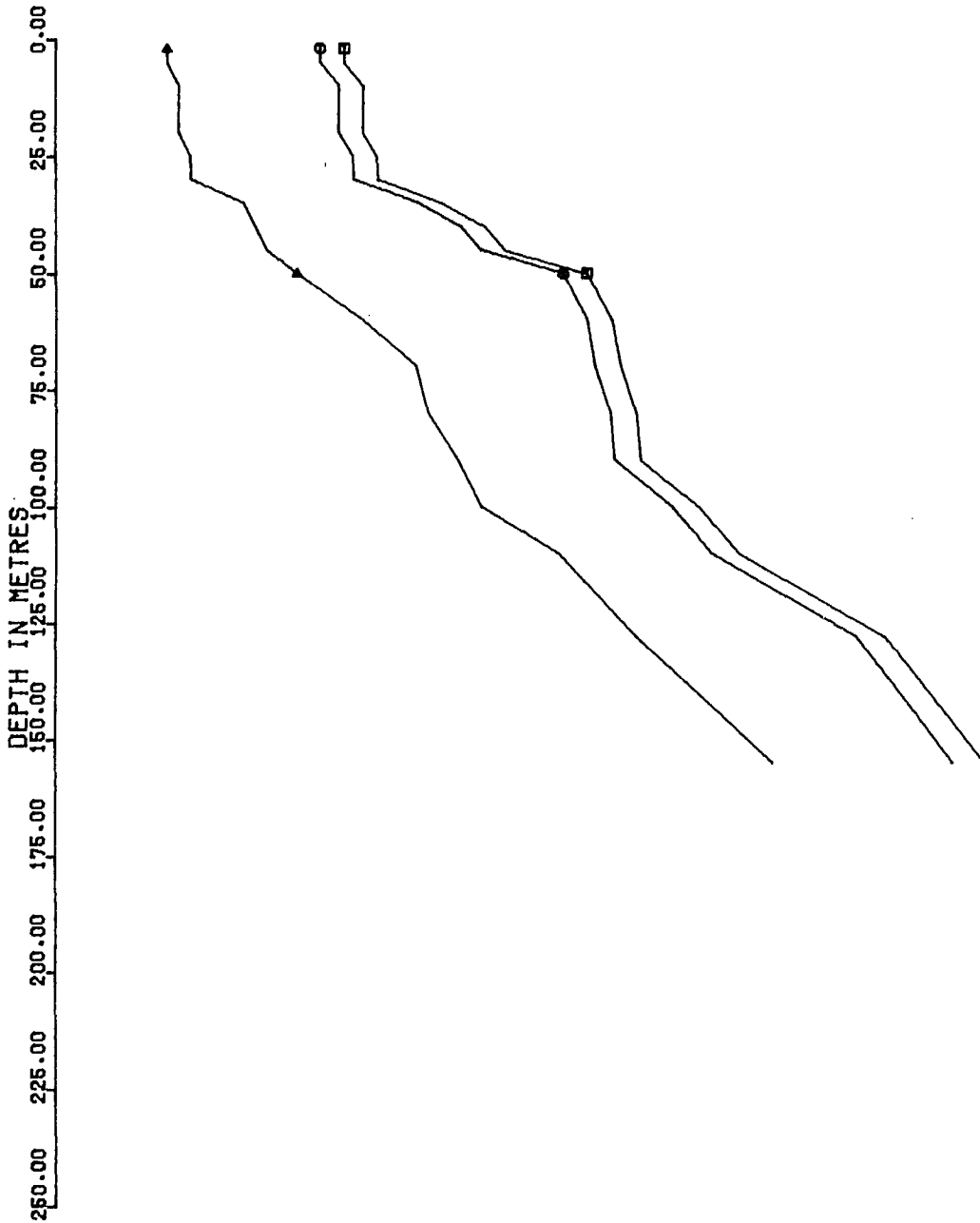
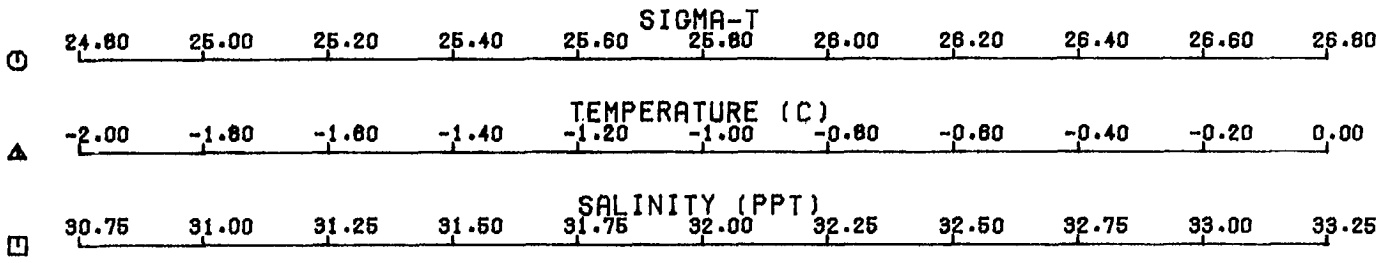

PENNY STRAIT

STATION 12 10 10

0230 GMT 14 4 1976 ICE= 0.8

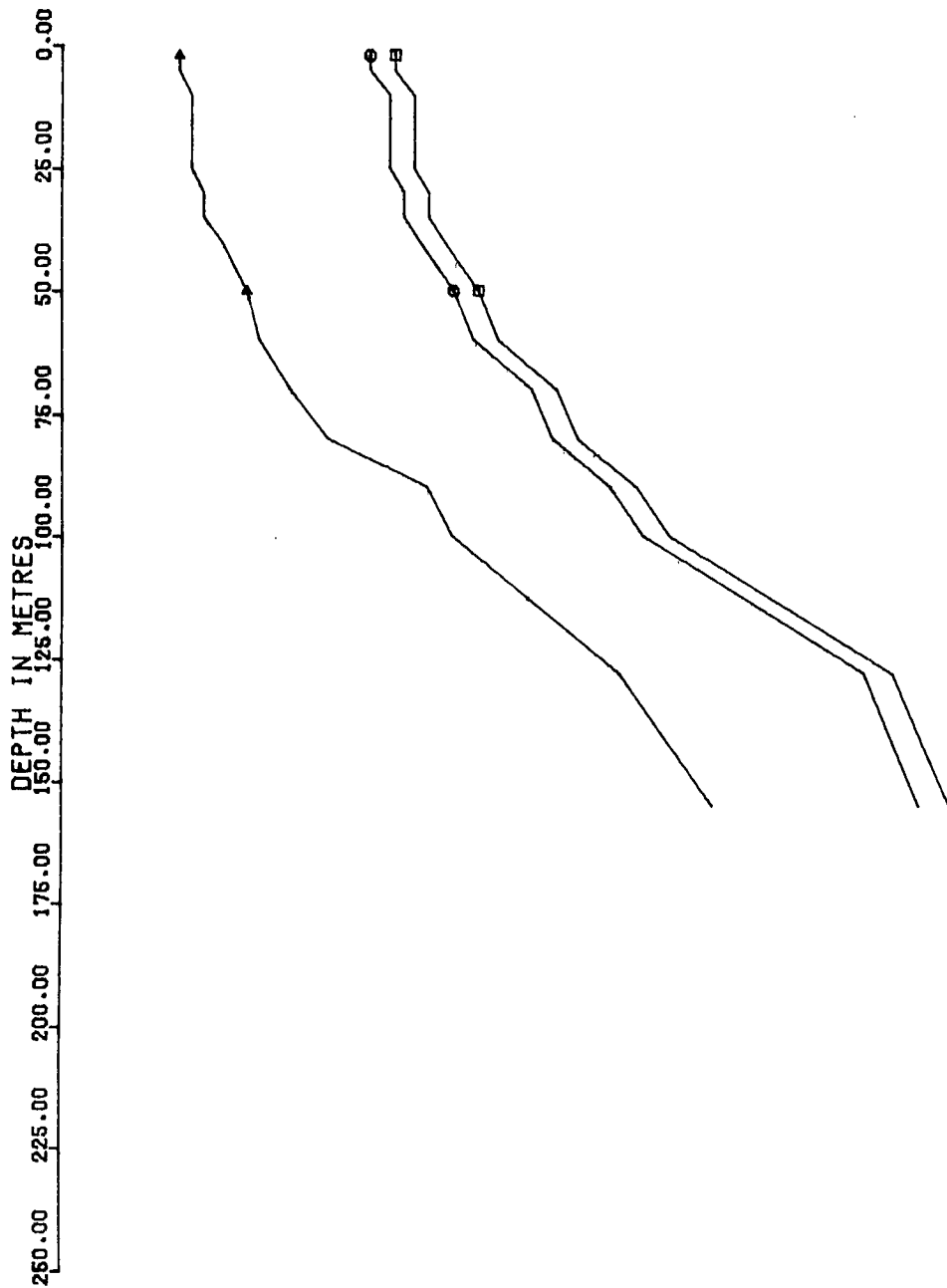
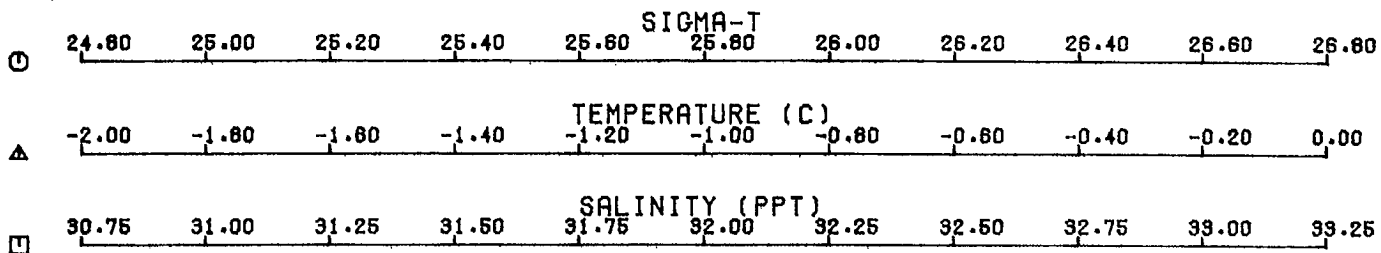

PENNY STRAIT 1976 DATA PROFILES. TENT STATION 12 11 11

LAT 76 41.50 CSTD 803 WATER DEPTH 187.0
 LONG 97 7.00 ICE 0.8 TIME (G.M.T.) 0330
 DATE 14 4 1976

DEPTH	SAL	TEMP	SIGMAT	SOUND
2.0	31.42	-1.81	25.30	1435.0
5.0	31.48	-1.81	25.34	1435.0
10.0	31.48	-1.81	25.34	1436.1
15.0	31.51	-1.79	25.37	1436.3
20.0	31.57	-1.79	25.42	1436.5
25.0	31.77	-1.79	25.42	1436.5
30.0	31.58	-1.75	25.42	1435.0
35.0	31.59	-1.72	25.46	1437.1
40.0	31.71	-1.66	25.53	1437.0
45.0	31.75	-1.63	25.56	1437.9
50.0	31.78	-1.61	25.58	1438.1
60.0	31.78	-1.61	25.58	1438.3
70.0	31.86	-1.52	25.67	1438.0
80.0	31.92	-1.37	25.80	1439.6
90.0	32.13	-1.13	25.85	1441.0
100.0	32.17	-1.13	25.89	1441.7
128.0	32.48	-0.99	25.13	1443.3
155.0	32.61	-0.85	25.21	1444.5

PENNY STRAIT 1976 DATA PROFILES. TENT STATION 12 12 12

LAT 76 41.50 CSTD 803 WATER DEPTH 187.0
 LONG 97 7.00 ICE 0.8 TIME (G.M.T.) 0430
 DATE 14 4 1976

DEPTH	SAL	TEMP	SIGMAT	SOUND
2.0	31.51	-1.79	25.37	1436.1
5.0	31.51	-1.73	25.37	1436.1
10.0	31.55	-1.77	25.40	1436.4
20.0	31.55	-1.77	25.40	1436.5
25.0	31.55	-1.77	25.40	1436.5
30.0	31.58	-1.74	25.42	1436.9
35.0	31.58	-1.74	25.42	1437.0
40.0	31.61	-1.72	25.45	1437.2
45.0	31.61	-1.72	25.45	1437.3
50.0	31.65	-1.70	25.48	1437.7
60.0	31.76	-1.59	25.57	1438.3
70.0	31.92	-1.37	25.69	1439.8
80.0	32.12	-1.24	25.85	1440.8
90.0	32.21	-1.17	25.93	1441.5
100.0	32.34	-1.13	26.02	1442.0
110.0	32.41	-1.04	26.08	1442.7
155.0	32.73	-0.82	26.33	1444.9

PENNY STRAIT

STATION 12 11 11

0330 GMT 14 4 1976 ICE= 0.8

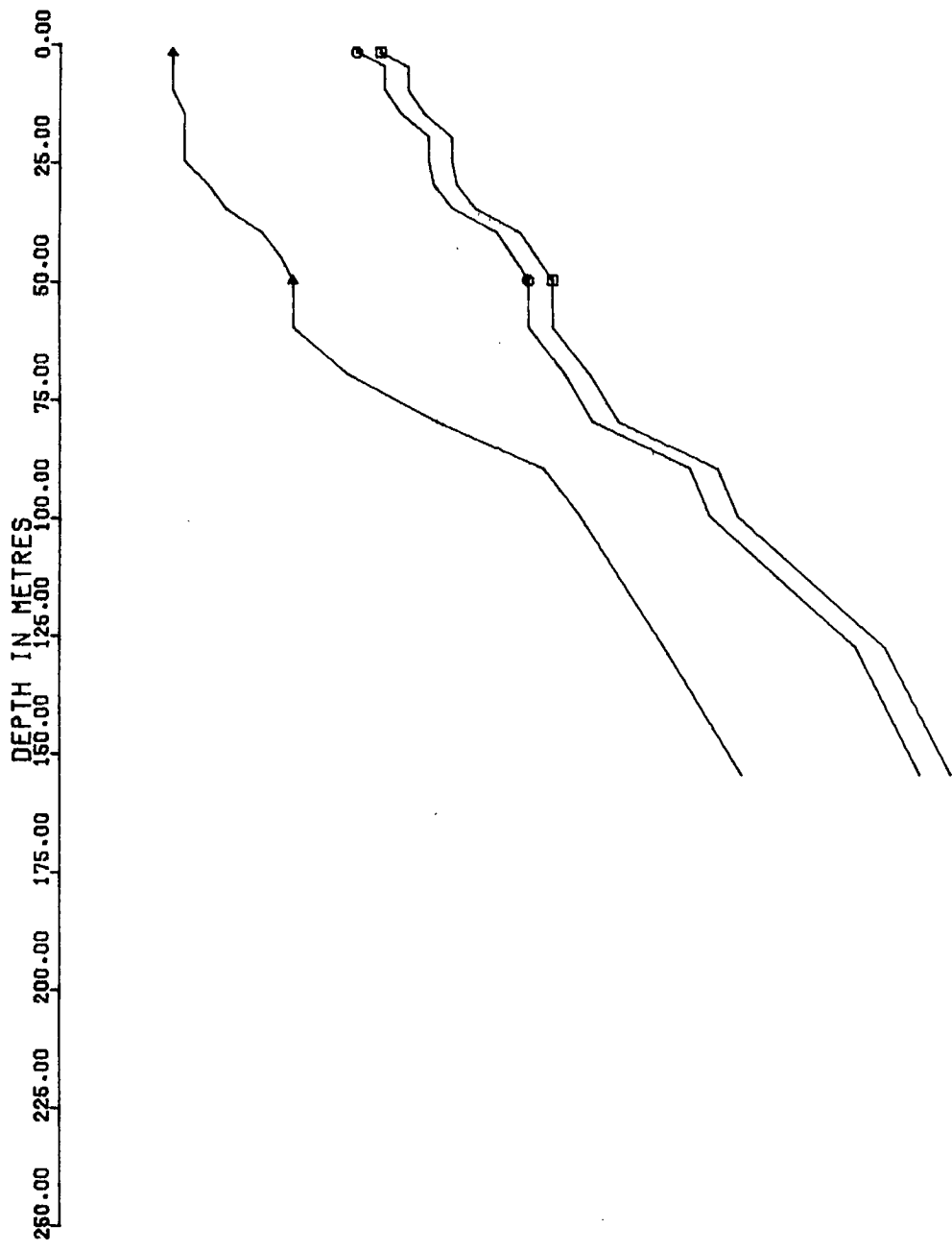
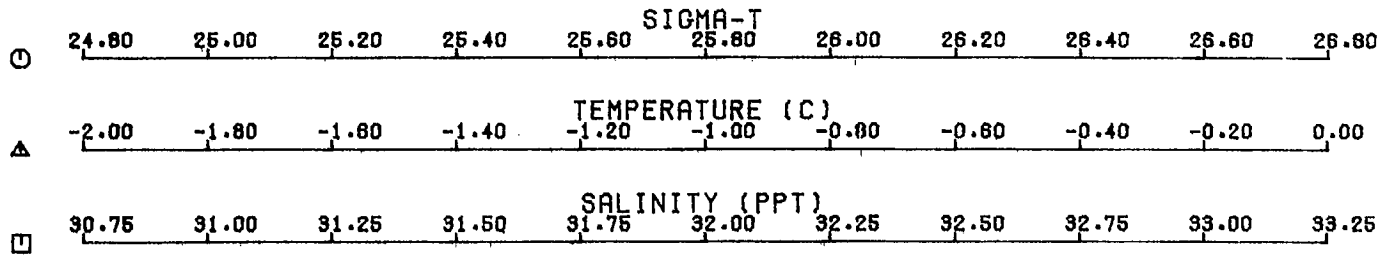

PENNY STRAIT

STATION 12 12 12

0430 GMT 14 4 1976 ICE= 0.6

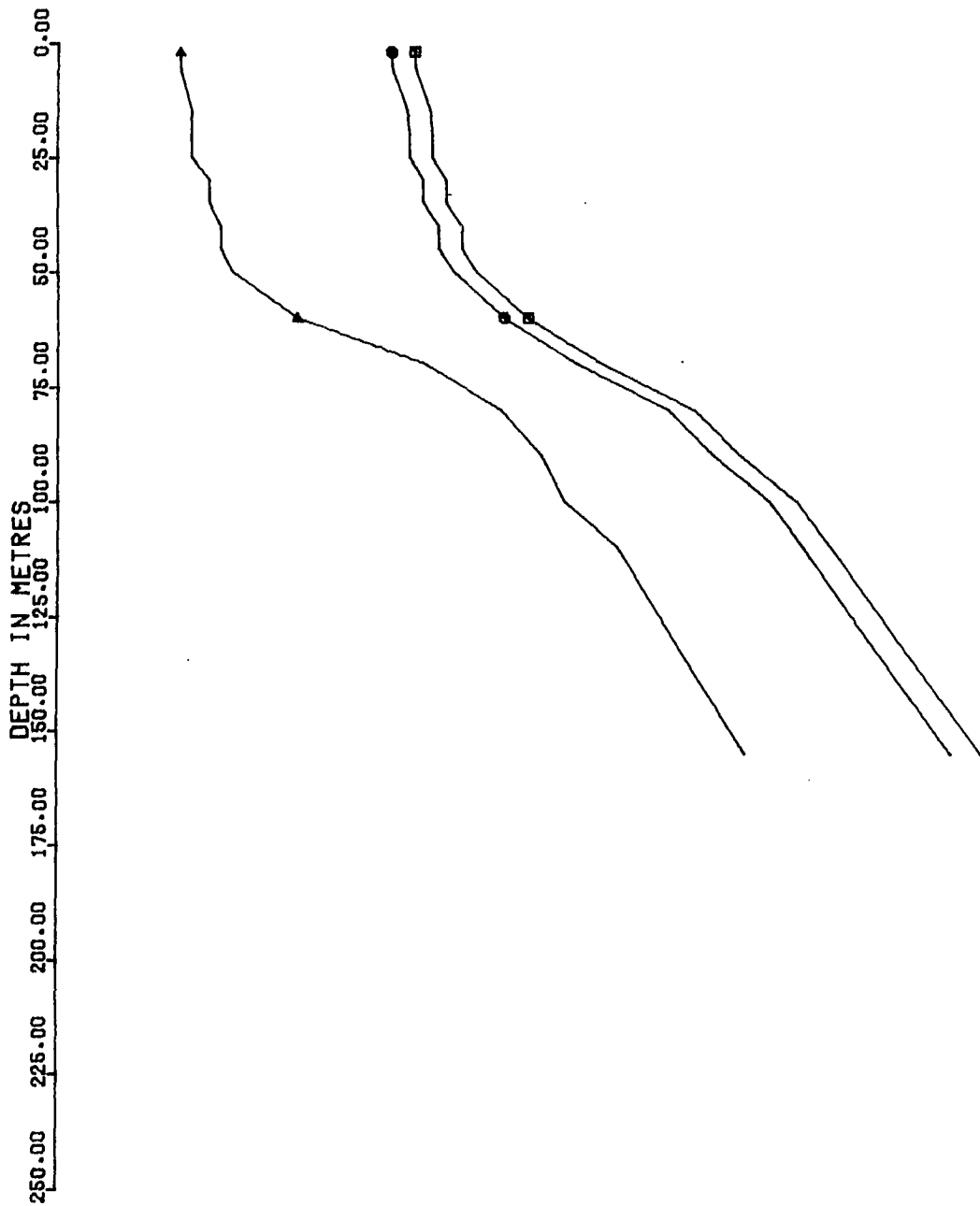
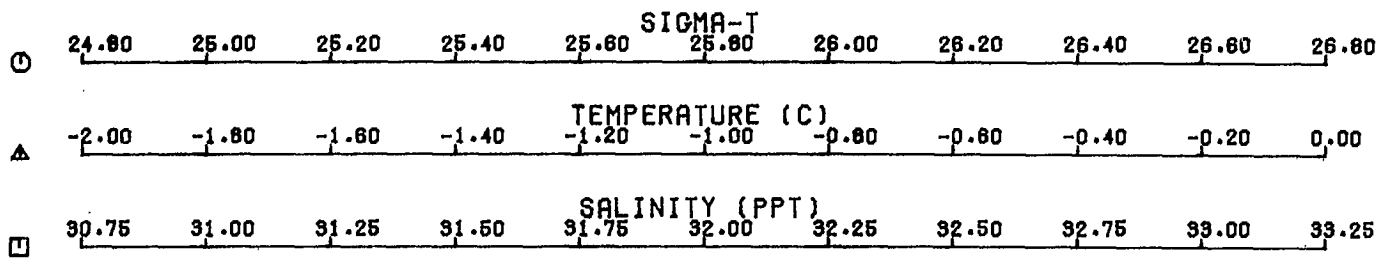

PENNY STRAIT 1976 DATA PROFILES. TENT STATION 12 13 13

LAT 76 41.50 COSTO 803 WATER DEPTH 187.0

LONG 97 7.00 ICE 0.8 TIME (G.M.T.) 0530

DATE 14 4 1976

DEPTH	SAL	TEMP	SIGMAT	SOUND
2.0	31.49	-1.77	225.35	1436.2
10.0	31.49	-1.77	225.35	1436.3
15.0	31.52	-1.74	225.38	1436.6
20.0	31.56	-1.72	225.40	1436.8
25.0	31.56	-1.72	225.40	1436.9
30.0	31.55	-1.70	225.46	1437.2
35.0	31.78	-1.61	225.58	1437.3
40.0	31.80	-1.46	225.68	1438.3
45.0	32.08	-1.28	225.82	1440.1
50.0	32.12	-1.24	225.85	1440.3
55.0	32.16	-1.17	225.89	1440.3
60.0	32.16	-1.15	225.93	1440.3
65.0	32.31	-1.10	225.99	1441.2
70.0	32.31	-1.10	225.99	1441.1
75.0	32.31	-1.10	225.99	1441.1
80.0	32.38	-1.09	225.99	1442.3
85.0	32.43	-1.05	225.10	1442.3
90.0	32.43	-1.05	225.10	1442.3
95.0	32.72	-0.75	225.32	1445.2

PENNY STRAIT 1976 DATA PROFILES. TENT STATION 12 14 14

LAT 76 41.50 COSTO 803 WATER DEPTH 187.0

LONG 97 7.00 ICE 0.8 TIME (G.M.T.) 0530

DATE 14 4 1976

DEPTH	SAL	TEMP	SIGMAT	SOUND
2.0	31.52	-1.74	225.38	1436.3
5.0	31.52	-1.74	225.38	1436.3
10.0	31.52	-1.74	225.38	1436.6
15.0	31.52	-1.74	225.38	1436.8
20.0	31.56	-1.74	225.42	1436.8
25.0	31.56	-1.74	225.42	1436.9
30.0	31.55	-1.70	225.48	1437.2
35.0	31.65	-1.70	225.48	1437.3
40.0	31.85	-1.53	225.61	1437.8
45.0	31.85	-1.53	225.61	1438.0
50.0	31.79	-1.57	225.66	1438.6
55.0	31.79	-1.57	225.66	1438.6
60.0	32.06	-1.24	225.80	1440.7
65.0	32.15	-1.21	225.87	1441.2
70.0	32.15	-1.21	225.87	1441.2
75.0	32.37	-1.13	225.92	1442.0

PENNY STRAIT

STATION 12 13 13

0530 GMT 14 4 1976 ICE= 0.8

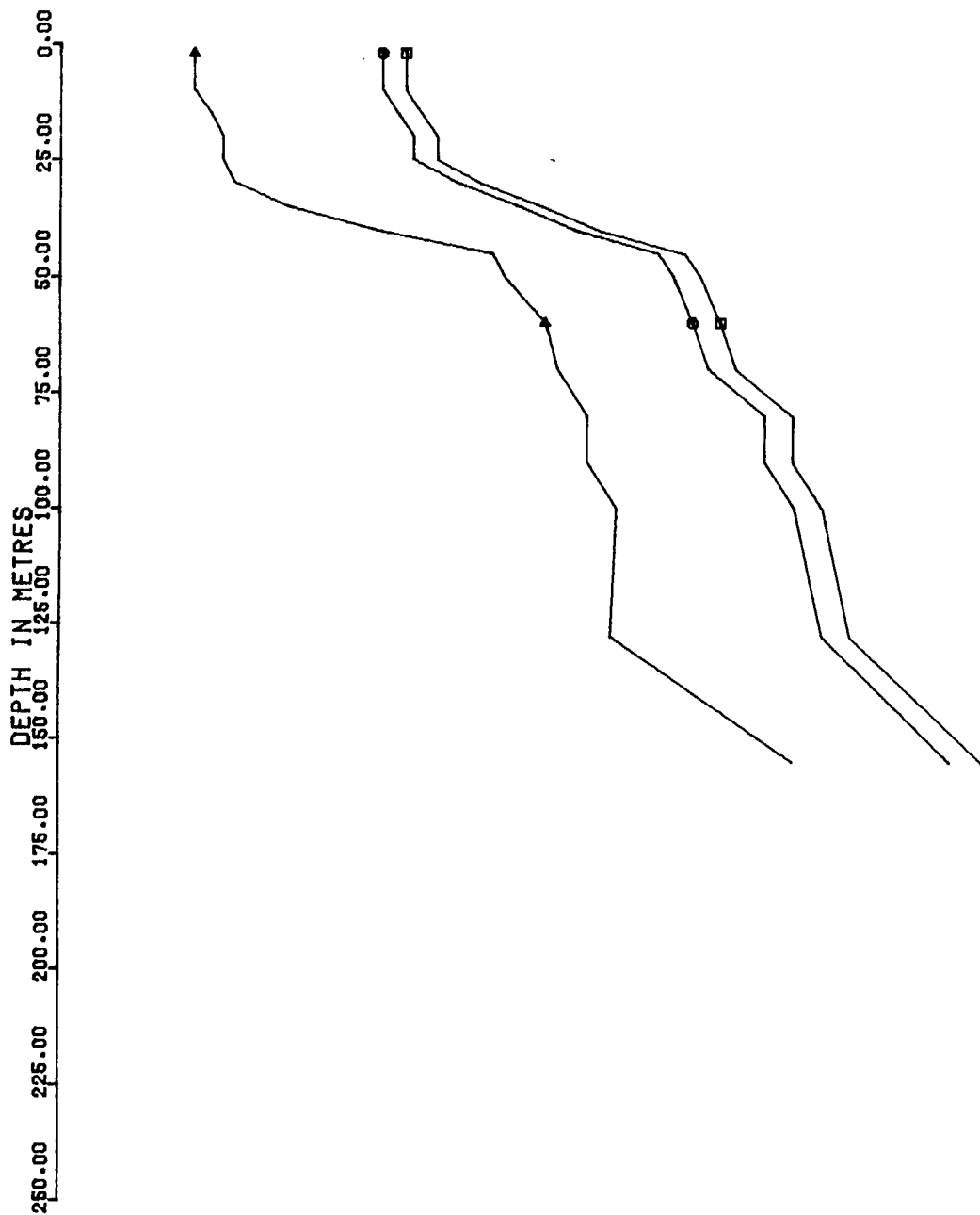
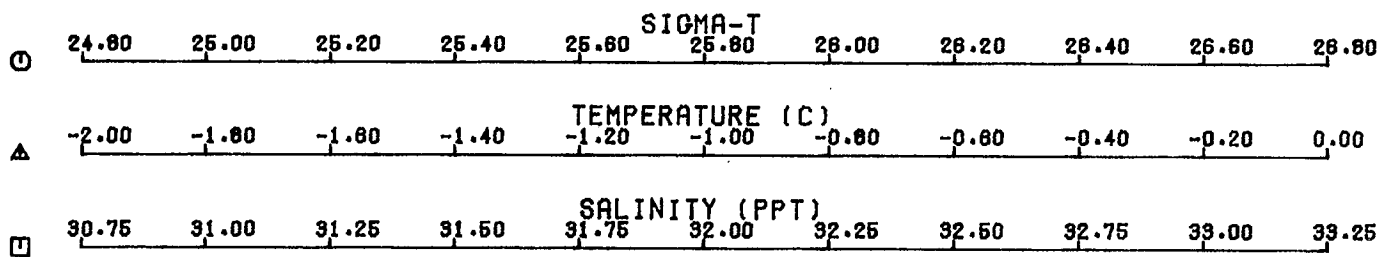

PENNY STRAIT

STATION 12 14 14

0630 GMT 14 4 1976 ICE= 0.8

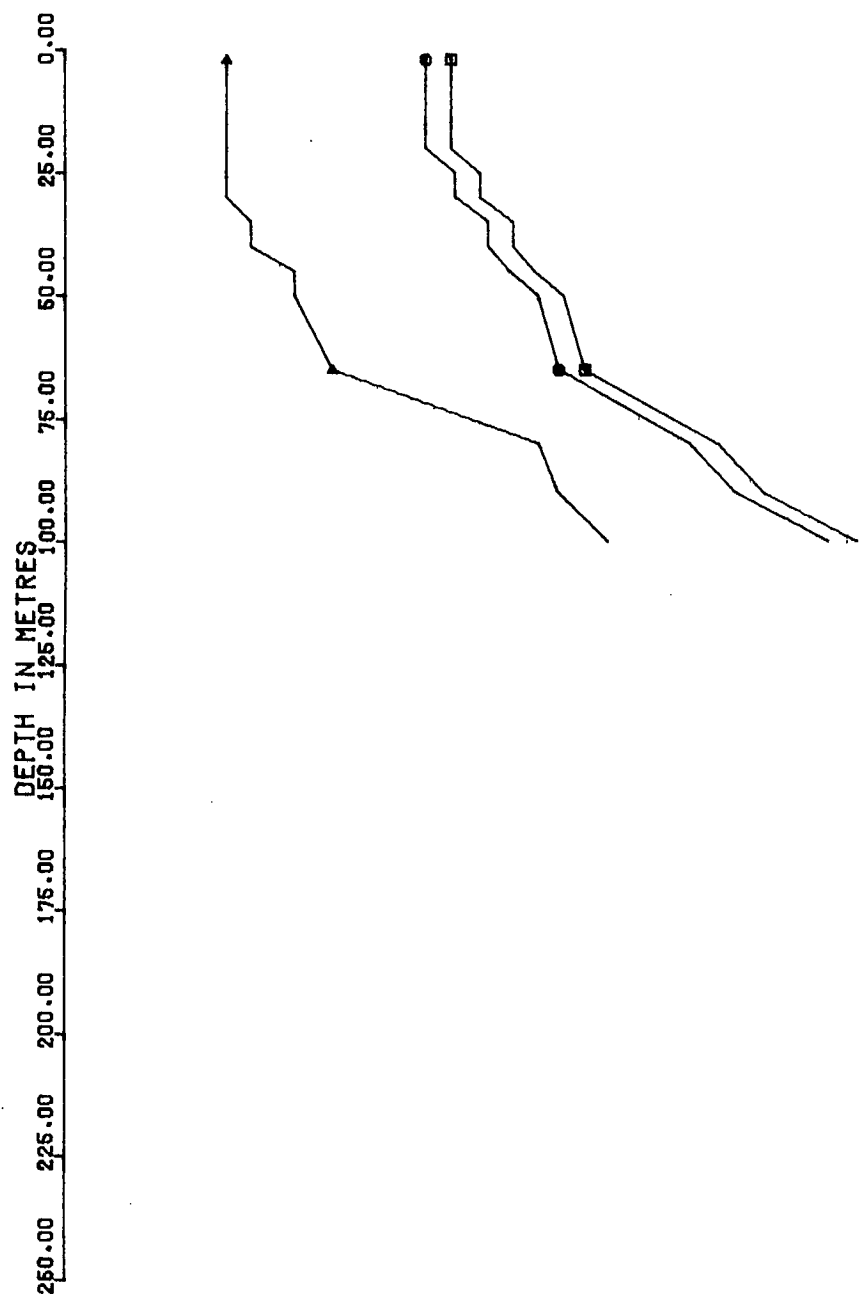
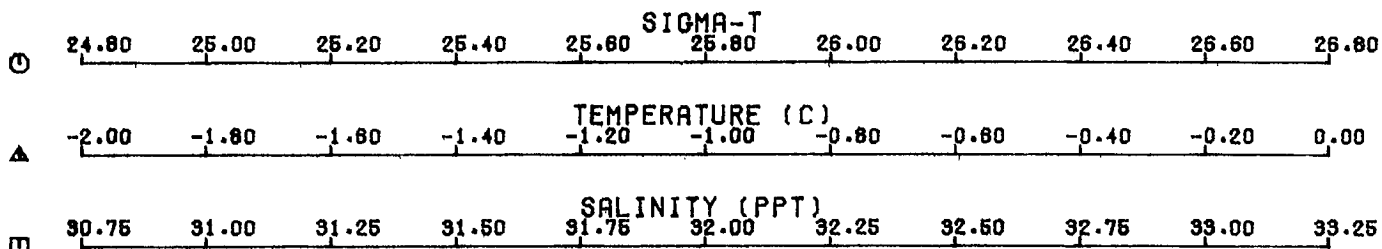

PENNY STRAIT 1976 DATA PROFILES. TENT STATION 14 1 15

LAT 76 38.60 CSTD 803 WATER DEPTH 260.0

LONG 97 23.80 ICE 2.0 TIME (G.M.T.) 1600

DATE 16 4 1976

DEPTH	SAL	TEMP	SIGMA T	SOUND
2.0	31.33	-1.72	25.22	1436.2
5.0	31.33	-1.72	25.22	1436.2
10.0	31.36	-1.70	25.25	1436.4
15.0	31.36	-1.70	25.25	1436.5
20.0	31.36	-1.70	25.25	1436.6
25.0	31.39	-1.68	25.27	1436.8
30.0	31.39	-1.68	25.27	1436.9
35.0	31.44	-1.61	25.31	1437.6
40.0	31.48	-1.59	25.34	1437.8
45.0	31.48	-1.55	25.34	1437.9
50.0	31.48	-1.55	25.34	1438.0
55.0	31.72	-1.39	25.33	1439.2
60.0	32.02	-1.15	25.77	1440.9
70.0	32.03	-1.10	25.77	1441.4
80.0	32.27	-1.02	25.97	1442.2
90.0	32.34	-0.97	25.97	1442.7
100.0	32.37	-0.95	25.97	1443.3
128.0	32.40	-0.93	25.97	1443.5
155.0	32.40	-0.93	25.97	1443.5
183.0	32.59	-0.84	25.22	1445.0
210.0	32.72	-0.71	25.32	1446.3

PENNY STRAIT 1976 DATA PROFILES. TENT STATION 14 2 16

LAT 76 38.60 CSTD 803 WATER DEPTH 260.0

LONG 97 23.80 ICE 2.0 TIME (G.M.T.) 1700

DATE 16 4 1976

DEPTH	SAL	TEMP	SIGMA T	SOUND
2.0	31.38	-1.72	25.26	1436.2
5.0	31.38	-1.72	25.26	1436.3
10.0	31.38	-1.72	25.26	1436.4
15.0	31.38	-1.72	25.26	1436.5
20.0	31.42	-1.70	25.29	1436.7
25.0	31.42	-1.70	25.29	1436.8
30.0	31.42	-1.70	25.29	1436.8
35.0	31.43	-1.66	25.30	1437.1
40.0	31.53	-1.59	25.38	1437.7
45.0	31.63	-1.52	25.46	1438.2
50.0	31.98	-1.21	25.74	1440.3
60.0	32.11	-1.13	25.84	1441.0
70.0	32.26	-1.06	25.96	1441.7
80.0	32.31	-0.99	25.99	1442.3
90.0	32.38	-0.95	25.99	1442.7
100.0	32.40	-0.93	25.97	1443.0
128.0	32.44	-0.90	25.10	1443.6
155.0	32.49	-0.90	25.14	1444.2
183.0	32.60	-0.79	25.22	1445.3
210.0	32.82	-0.64	25.40	1446.7

PENNY STRAIT

STATION 14 1 15

1600 GMT 16 4 1976 ICE= 2.0

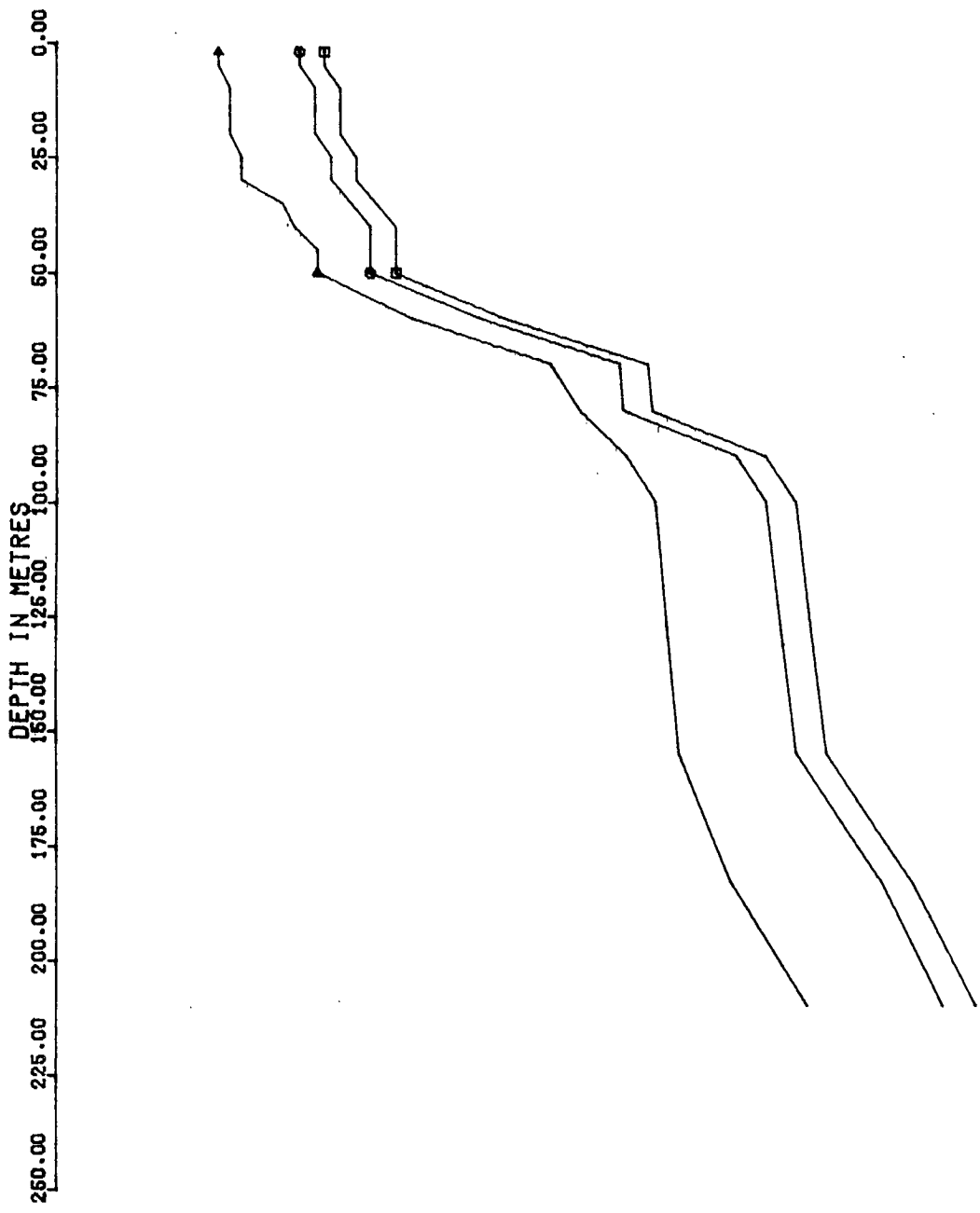
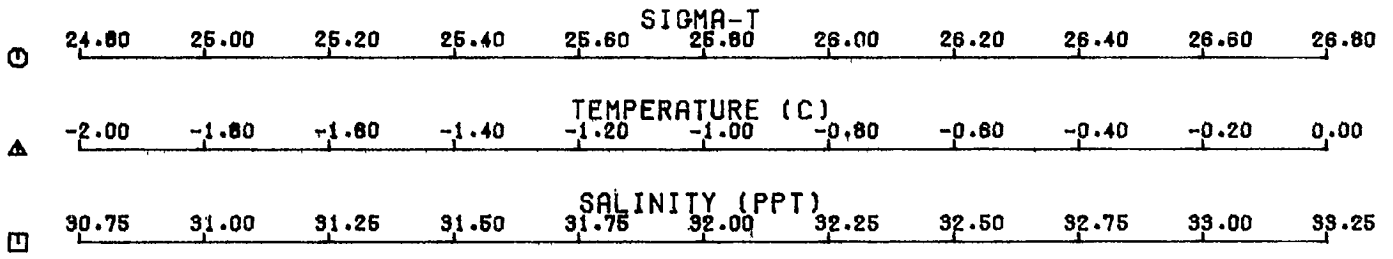

PENNY STRAIT

STATION 14 2 16

1700 GMT 16 4 1976 ICE= 2.0

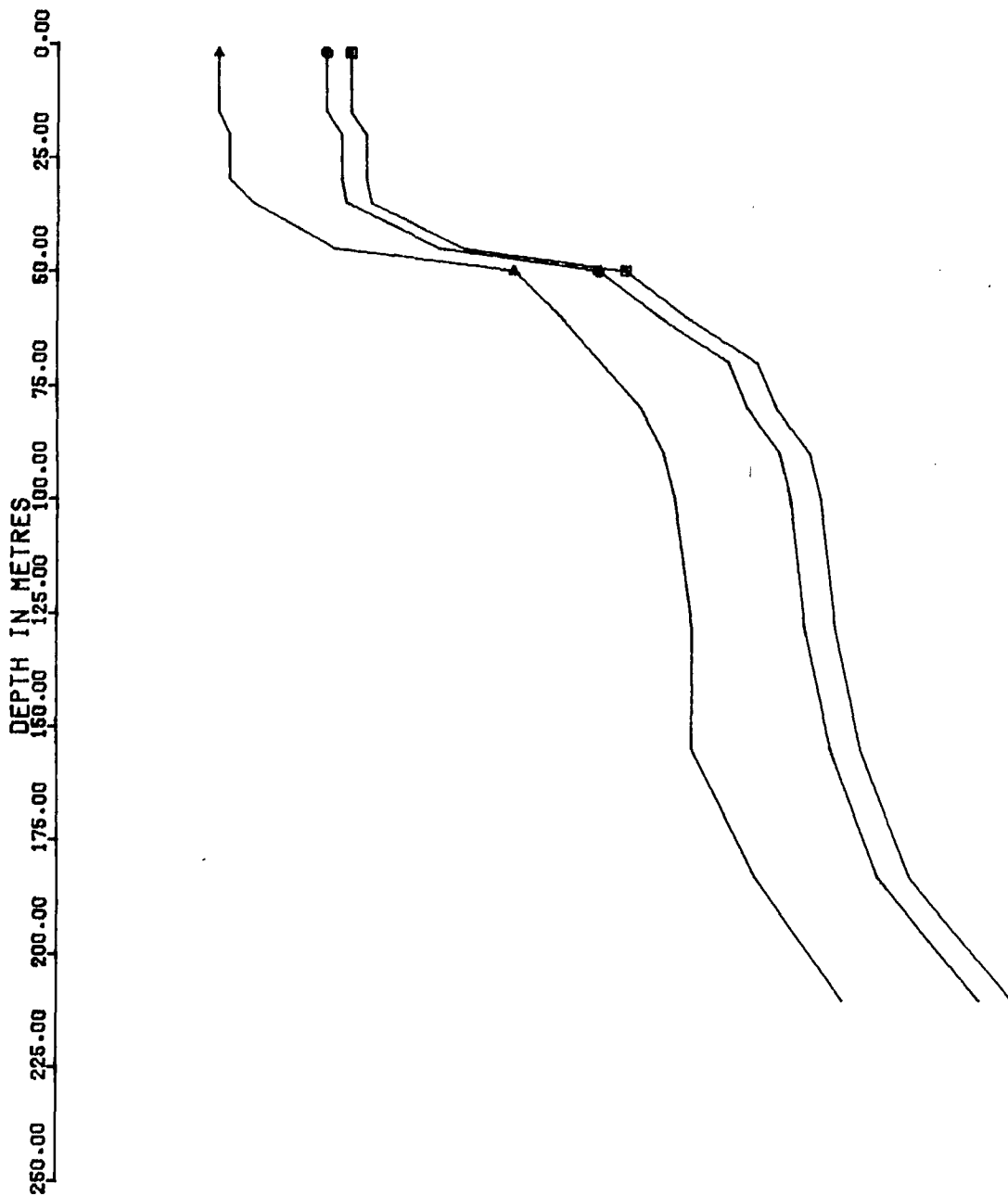
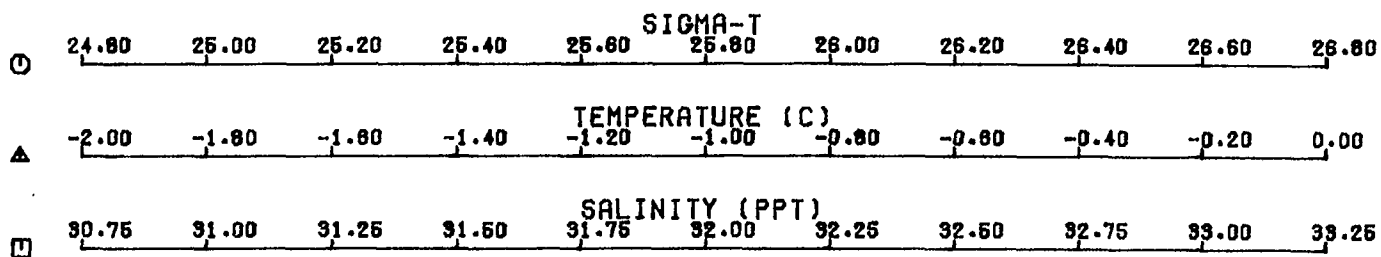

PENNY STRAIT 1976 DATA PROFILES. TENT STATION 14 3 17

LAT 76 38.60 CSTD 803 WATER DEPTH 260.0

LONG 97 23.80 ICE 2.0 TIME (G.M.T.) 1800

DATE 16 4 1976

DEPTH	SAL	TEMP	SIGMAT	SOUND
2.0	31.38	-1.72	25.26	1436.2
5.0	31.42	-1.70	25.29	1436.4
10.0	31.42	-1.70	25.29	1436.5
15.0	31.42	-1.70	25.29	1436.5
20.0	31.45	-1.68	25.32	1436.8
25.0	31.45	-1.68	25.32	1436.8
30.0	31.53	-1.59	25.38	1437.5
35.0	31.56	-1.57	25.41	1437.7
40.0	31.57	-1.52	25.41	1438.1
45.0	31.67	-1.46	25.49	1438.6
50.0	31.71	-1.41	25.55	1439.0
60.0	31.90	-1.30	25.68	1439.0
70.0	31.95	-1.24	25.71	1440.5
80.0	32.01	-1.19	25.76	1440.9
90.0	32.32	-1.05	25.01	1442.1
100.0	32.33	-1.02	25.01	1442.5
120.0	32.44	-0.90	26.10	1443.6
150.0	32.50	-0.86	26.15	1444.7
183.0	32.66	-0.73	26.27	1445.5
210.0	32.81	-0.68	26.39	1446.5

PENNY STRAIT 1976 DATA PROFILES. TENT STATION 14 4 18

LAT 76 38.60 CSTD 803 WATER DEPTH 260.0

LONG 97 23.80 ICE 2.0 TIME (G.M.T.) 1900

DATE 16 4 1976

DEPTH	SAL	TEMP	SIGMAT	SOUND
2.0	31.36	-1.70	25.25	1436.3
5.0	31.42	-1.70	25.29	1436.7
10.0	31.42	-1.70	25.29	1436.5
15.0	31.42	-1.68	25.32	1436.7
20.0	31.45	-1.68	25.32	1436.8
25.0	31.48	-1.65	25.35	1437.0
30.0	31.48	-1.65	25.34	1437.1
35.0	31.50	-1.61	25.35	1437.5
40.0	31.63	-1.52	25.46	1438.2
45.0	31.64	-1.48	25.47	1438.4
50.0	31.70	-1.43	25.51	1438.6
60.0	31.72	-1.39	25.53	1439.2
70.0	32.08	-1.15	25.81	1441.0
80.0	32.32	-1.06	26.01	1442.0
90.0	32.44	-0.90	26.10	1443.0
100.0	32.50	-0.86	26.15	1443.5
138.0	32.63	-0.77	26.25	1444.7
155.0	32.66	-0.75	26.27	1445.1
183.0	32.82	-0.64	26.40	1446.3
210.0	32.85	-0.62	26.42	1446.9

PENNY STRAIT

STATION 14 3 17

1800 GMT 16 4 1976 ICE= 2.0

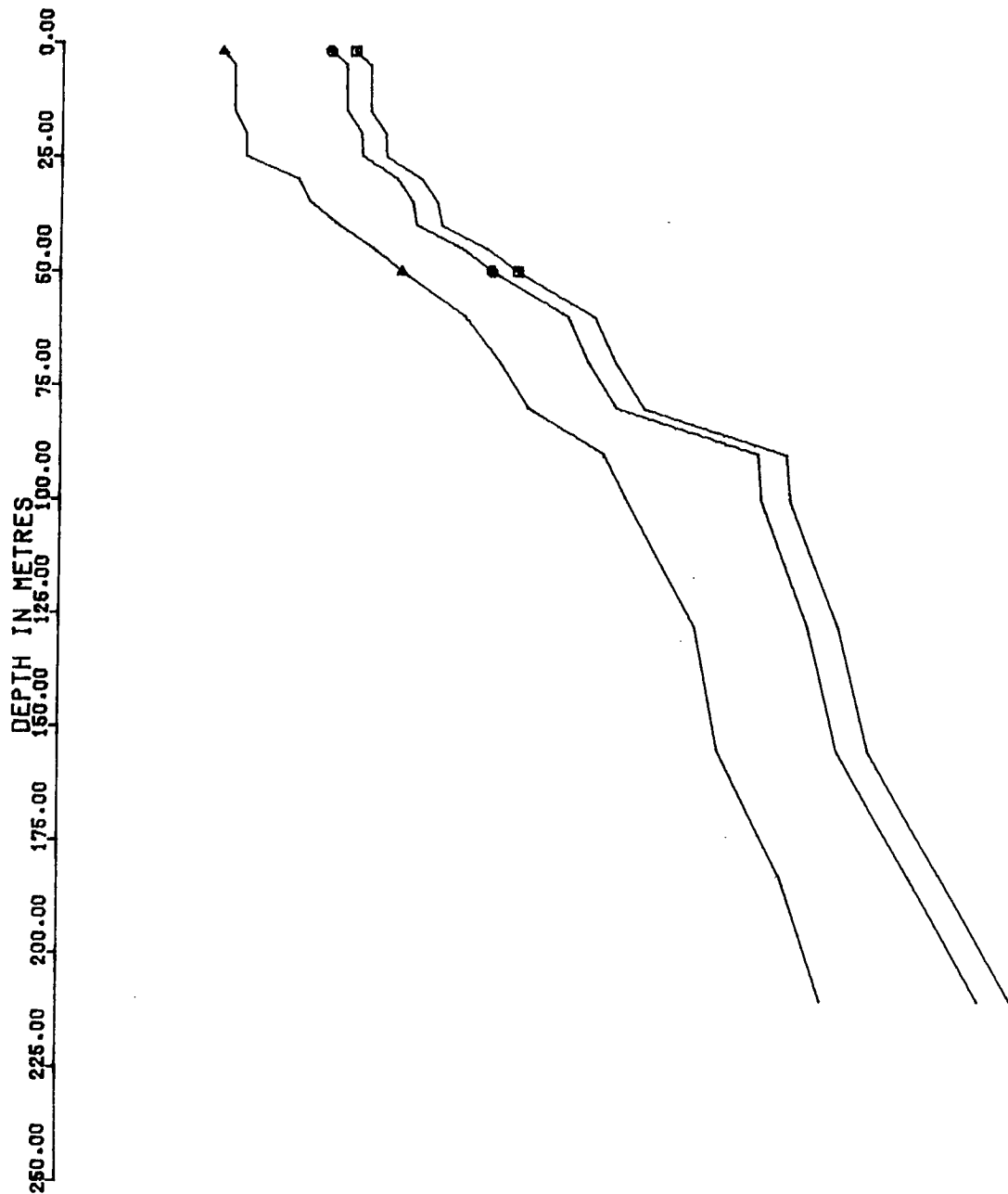
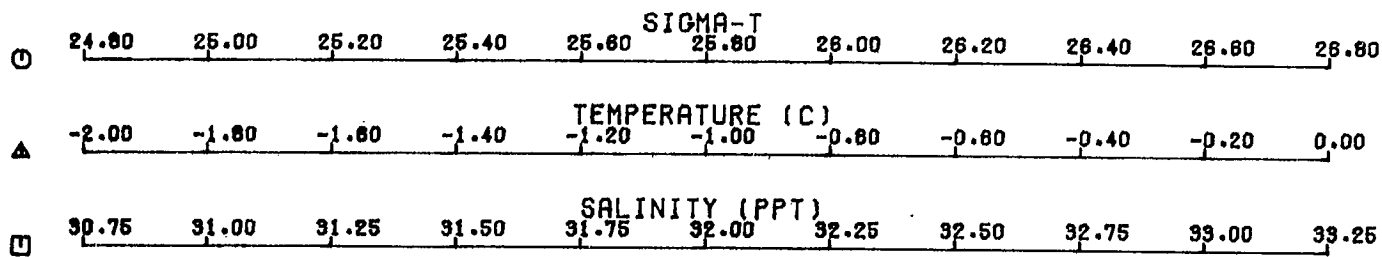

PENNY STRAIT

STATION 14 4 18

1900 GMT 16 4 1976 ICE= 2.0

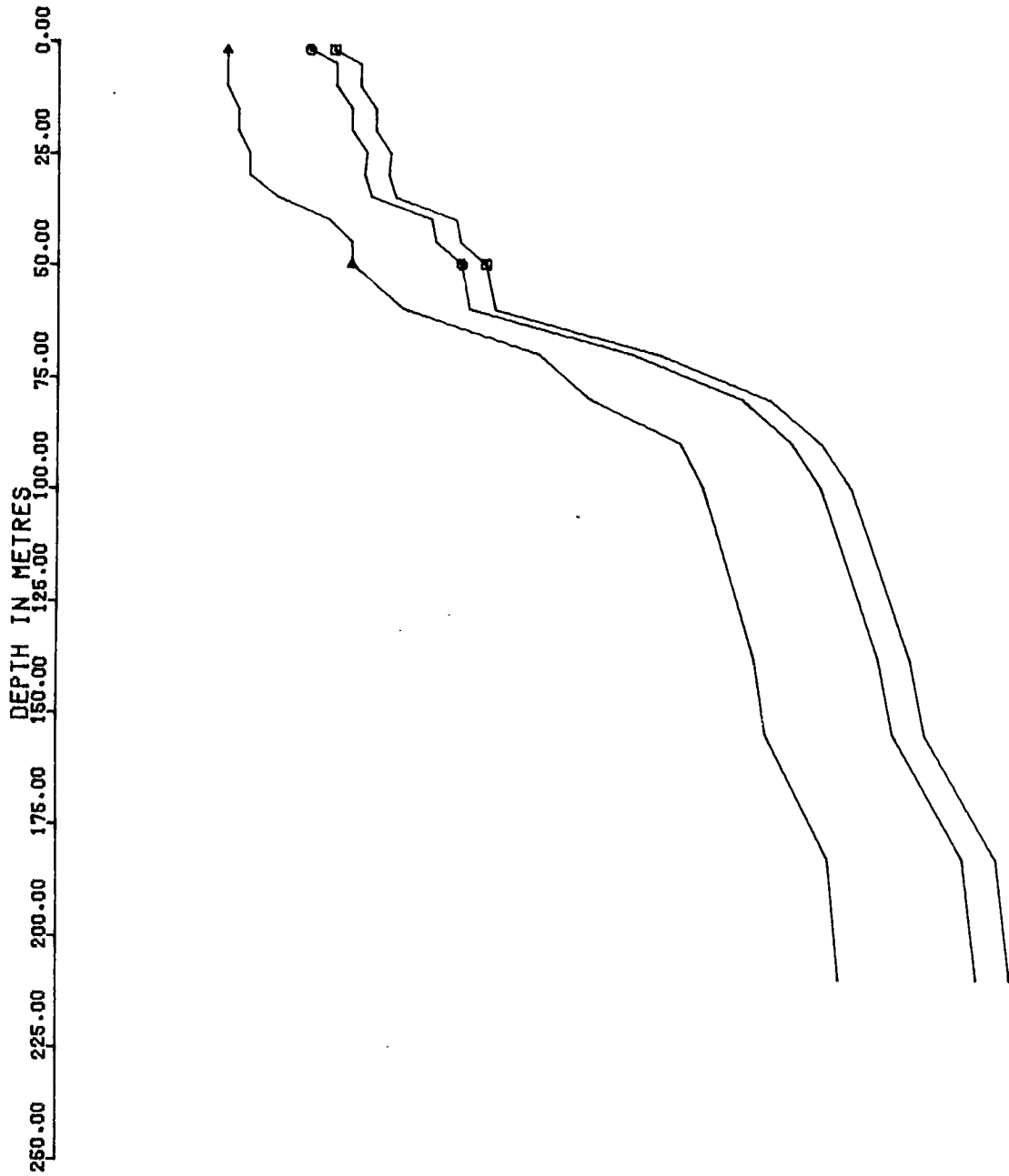
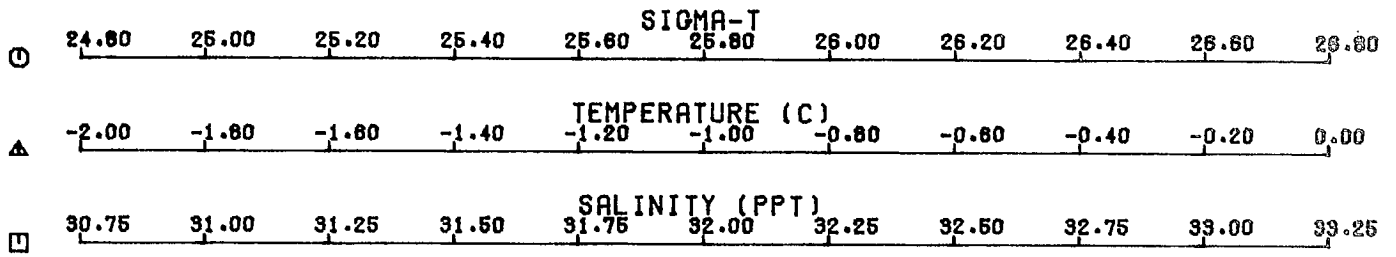

PENNY STRAIT 1976 DATA PROFILES. TENT STATION 14 5 19

LAT 76 38.60 OSTD 803 WATER DEPTH 260.0
 LONG 97 23.80 ICE 2.0 TIME (G.M.T.) 2000
 DATE 16 4 1976

DEPTH	SAL	TEMP	SIGMAT	SOUND
2.0	31.38	-1.72	25.26	1436.2
5.0	31.42	-1.70	25.29	1436.4
10.0	31.42	-1.70	25.29	1436.5
15.0	31.42	-1.70	25.29	1436.6
20.0	31.43	-1.66	25.30	1436.8
25.0	31.46	-1.63	25.33	1437.2
30.0	31.52	-1.63	25.37	1437.3
35.0	31.53	-1.59	25.38	1437.6
40.0	31.56	-1.57	25.41	1437.8
45.0	31.64	-1.48	25.47	1438.4
50.0	31.75	-1.40	25.57	1438.8
60.0	31.81	-1.37	25.60	1439.4
70.0	31.81	-1.37	25.60	1439.6
80.0	31.87	-1.32	25.65	1440.1
90.0	31.91	-1.26	25.68	1440.6
100.0	32.11	-1.13	25.81	1441.2
128.0	32.22	-0.93	25.99	1443.2
155.0	32.31	-0.68	26.30	1445.6
175.0	32.84	-0.65	26.41	1446.1
210.0	32.34	-0.65	26.42	1446.7

PENNY STRAIT 1976 DATA PROFILES. TENT STATION 14 6 20

LAT 76 38.60 OSTD 803 WATER DEPTH 260.0
 LONG 97 23.80 ICE 2.0 TIME (G.M.T.) 2100
 DATE 15 4 1976

DEPTH	SAL	TEMP	SIGMAT	SOUND
2.0	31.38	-1.72	25.26	1436.2
5.0	31.38	-1.72	25.26	1436.3
10.0	31.38	-1.72	25.26	1436.4
15.0	31.42	-1.70	25.29	1436.6
20.0	31.45	-1.68	25.32	1436.8
25.0	31.48	-1.65	25.34	1437.0
30.0	31.52	-1.63	25.37	1437.3
35.0	31.56	-1.59	25.40	1438.2
40.0	31.71	-1.44	25.49	1438.8
45.0	31.74	-1.41	25.55	1438.9
50.0	31.81	-1.37	25.60	1439.3
60.0	31.81	-1.32	25.61	1439.7
70.0	31.88	-1.28	25.66	1440.1
80.0	32.01	-1.13	25.76	1440.9
90.0	32.08	-1.15	25.81	1441.5
100.0	32.11	-1.13	25.84	1441.7
128.0	32.46	-0.93	26.12	1443.5
155.0	32.64	-0.84	26.26	1444.7
183.0	32.78	-0.71	26.37	1445.5
210.0	32.32	-0.64	26.40	1445.7

PENNY STRAIT

STATION 14 5 19

2000 GMT 16 4 1976 ICE= 2.0

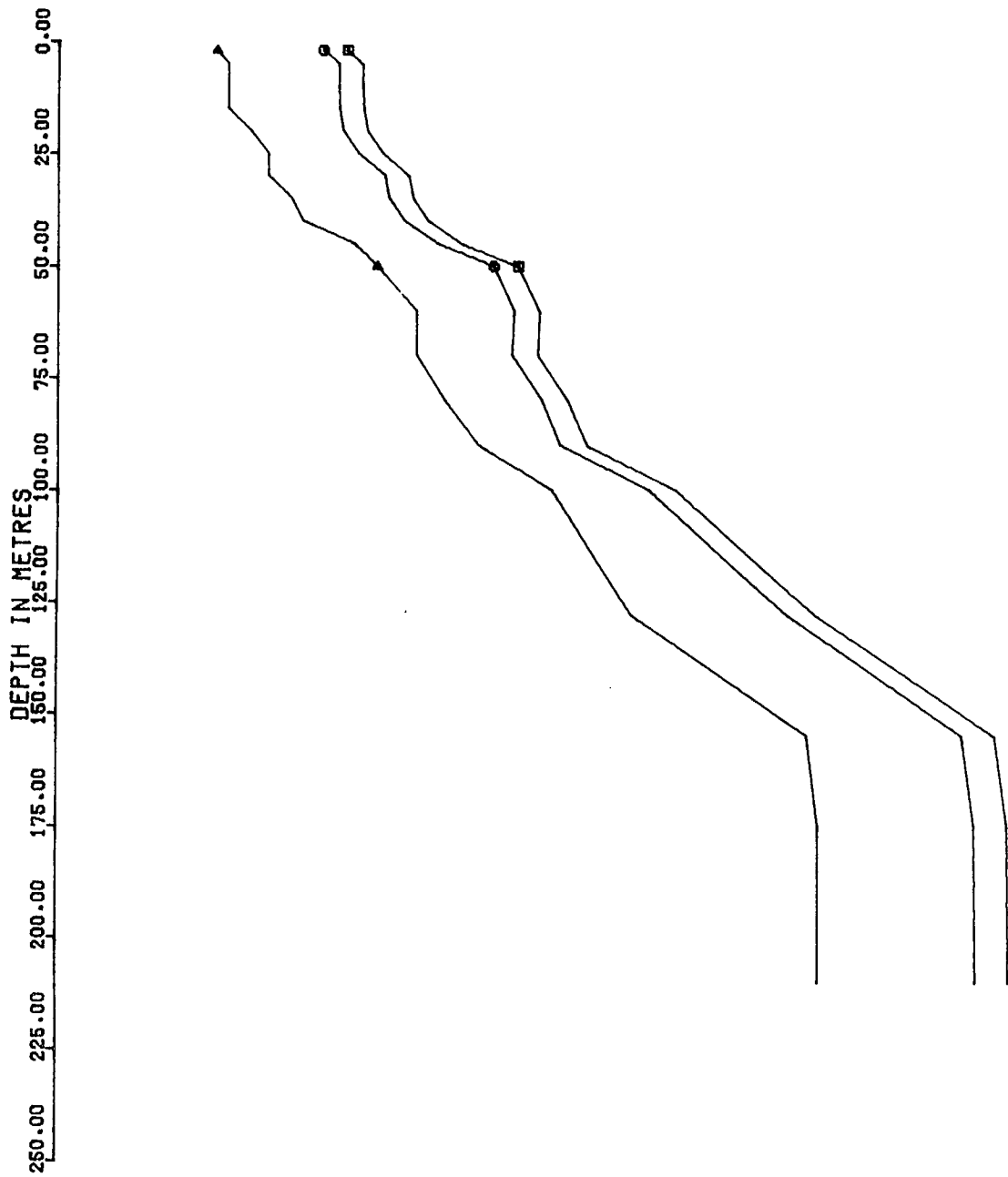
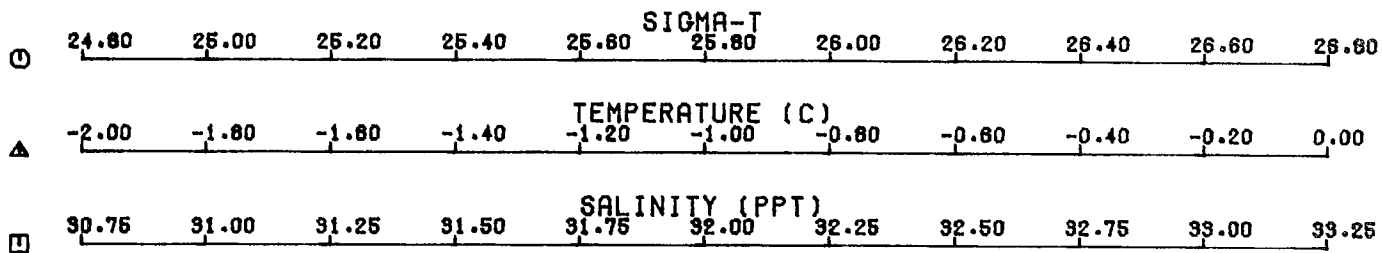

PENNY STRAIT

STATION 14 6 20

2100 GMT 16 4 1976 ICE= 2.0

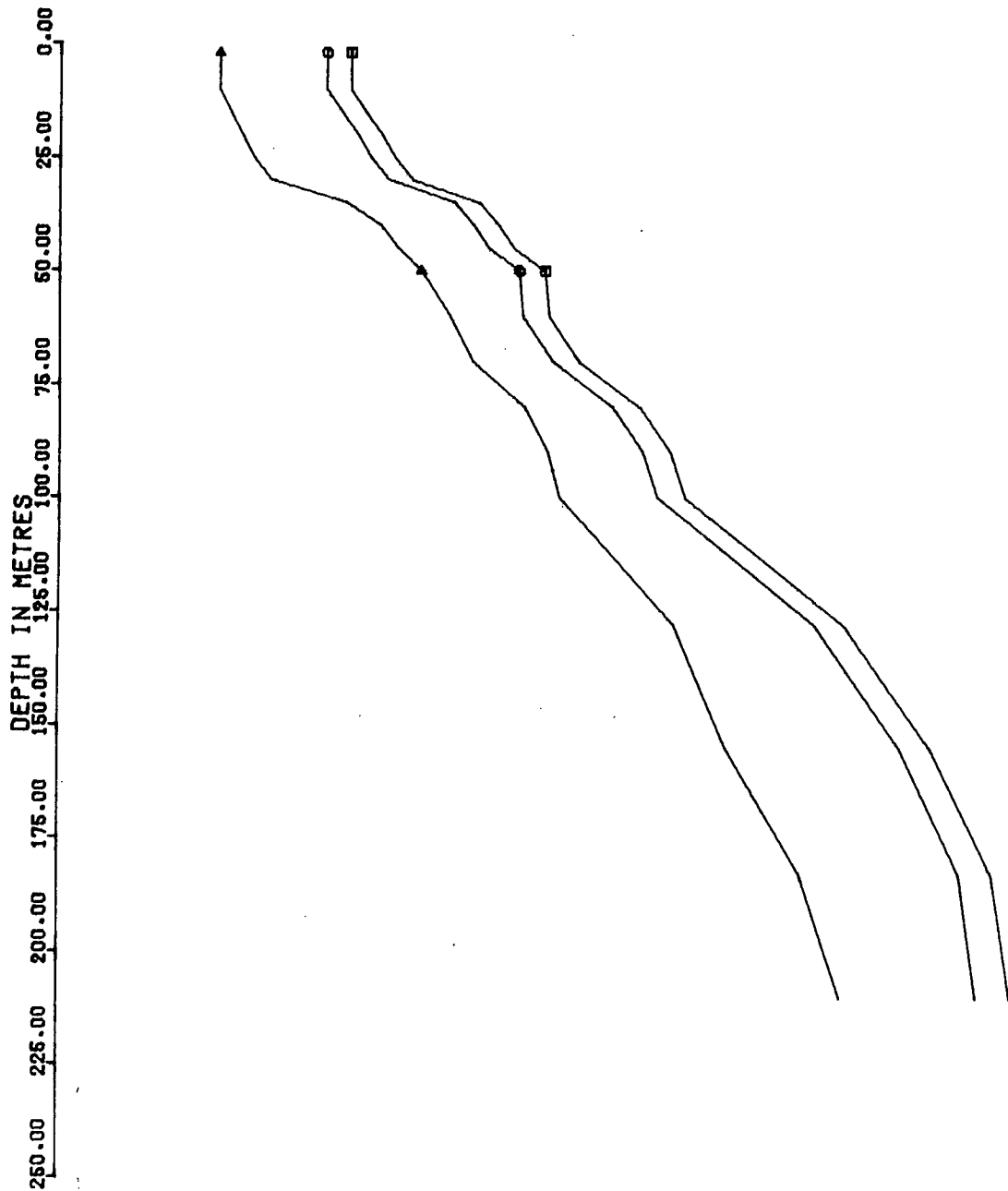
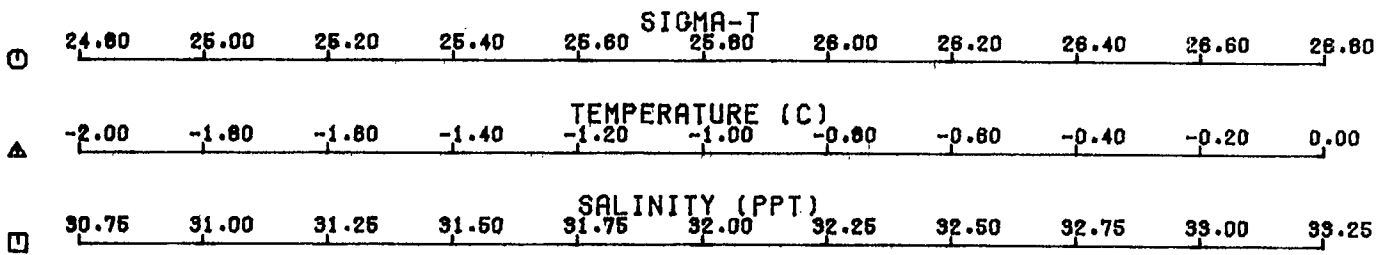

PENNY STRAIT 1976 DATA PROFILES. TENT STATION 14 7 21
 LAT 76 38.60 CSTD 893 WATER DEPTH 260.0
 LONG 97 23.80 ICE 2.0 TIME (G.M.T.) 2200
 DATE 15 4 1976

DEPTH	SAL	TEMP	SIGMAT	SOUND
2.0	31.38	-1.72	25.25	1436.3
5.0	31.38	-1.72	25.26	1436.3
10.0	31.38	-1.72	25.26	1436.4
15.0	31.42	-1.70	25.29	1436.6
20.0	31.45	-1.68	25.32	1436.7
25.0	31.48	-1.66	25.35	1437.0
30.0	31.56	-1.57	25.41	1437.7
35.0	31.66	-1.50	25.49	1438.3
40.0	31.66	-1.50	25.53	1438.3
45.0	31.74	-1.41	25.59	1438.6
50.0	31.81	-1.32	25.61	1439.5
55.0	31.94	-1.28	25.70	1440.1
70.0	31.95	-1.24	25.71	1440.1
80.0	32.01	-1.19	25.76	1440.5
90.0	32.05	-1.17	25.79	1441.3
100.0	32.05	-1.17	25.79	1441.3
120.0	32.08	-1.15	25.81	1442.3
150.0	32.42	-0.99	25.99	1443.5
180.0	32.56	-0.86	26.10	1444.9
210.0	32.76	-0.71	26.37	1446.1

PENNY STRAIT 1976 DATA PROFILES. TENT STATION 14 8 22
 LAT 76 38.60 CSTD 803 WATER DEPTH 260.0
 LONG 97 23.80 ICE 2.0 TIME (G.M.T.) 2300
 DATE 15 4 1976

DEPTH	SAL	TEMP	SIGMAT	SOUND
2.0	31.35	-1.85	25.24	1435.6
5.0	31.39	-1.72	25.27	1436.3
10.0	31.39	-1.72	25.27	1436.4
15.0	31.42	-1.70	25.29	1436.6
20.0	31.42	-1.70	25.29	1436.7
25.0	31.45	-1.68	25.32	1436.9
30.0	31.46	-1.63	25.33	1437.3
35.0	31.50	-1.61	25.35	1437.5
40.0	31.53	-1.59	25.38	1437.7
45.0	31.56	-1.57	25.41	1437.9
50.0	31.60	-1.55	25.43	1438.1
55.0	31.63	-1.52	25.46	1438.7
70.0	31.79	-1.30	25.59	1439.9
80.0	32.01	-1.19	25.76	1440.5
90.0	32.02	-1.15	25.77	1441.3
100.0	32.11	-1.13	25.84	1441.7
120.0	32.32	-1.06	26.01	1442.7
135.0	32.49	-0.90	26.14	1444.2
180.0	32.62	-0.82	26.24	1445.2
210.0	32.72	-0.75	26.32	1446.1

PENNY STRAIT

STATION 14 7 21

2200 GMT 16 4 1976 ICE= 2.0

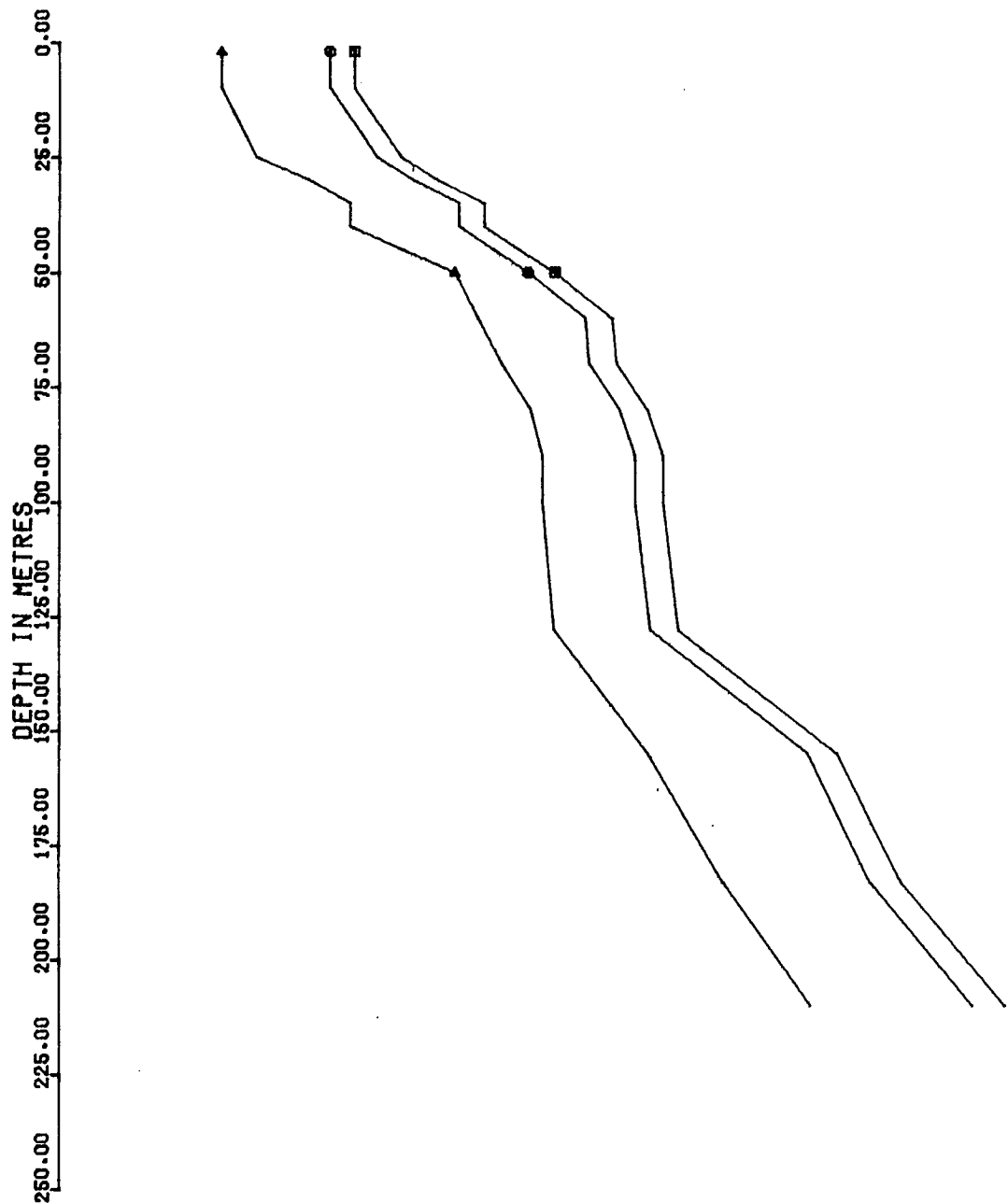
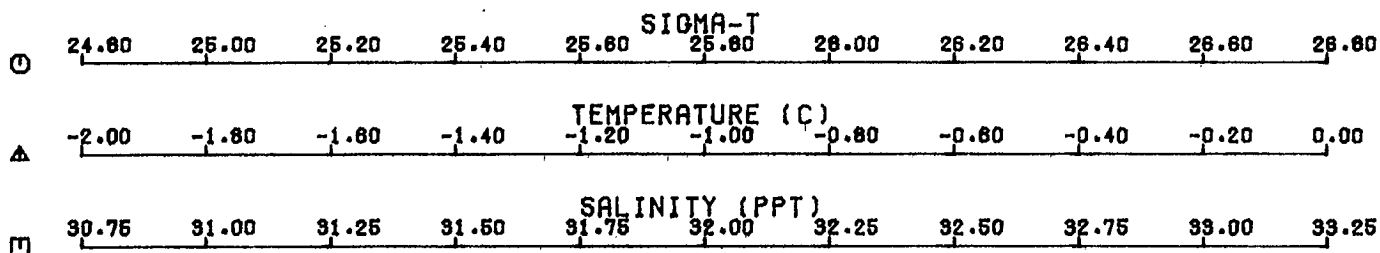

PENNY STRAIT

STATION 14 8 22

2300 GMT 16 4 1976 ICE= 2.0

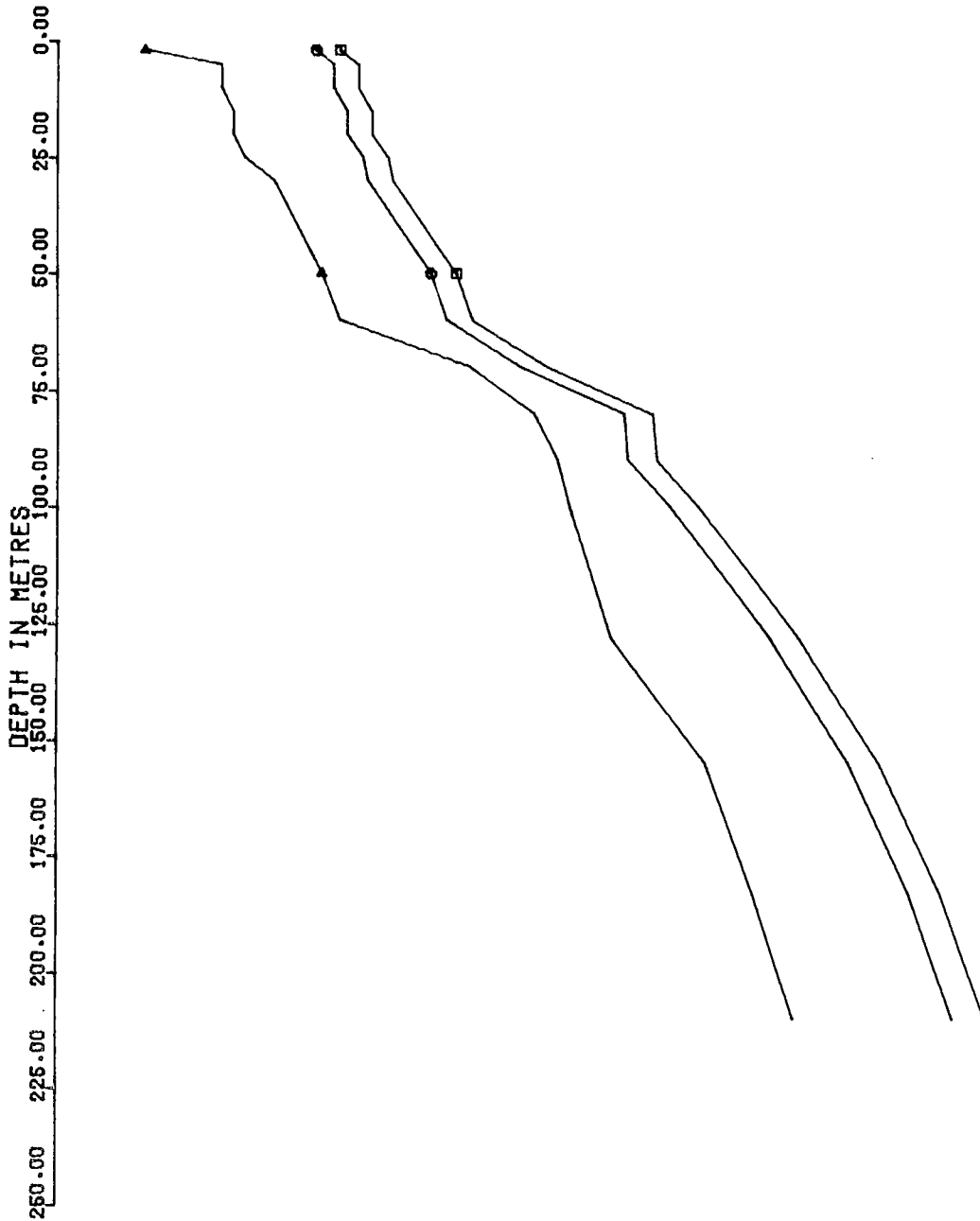
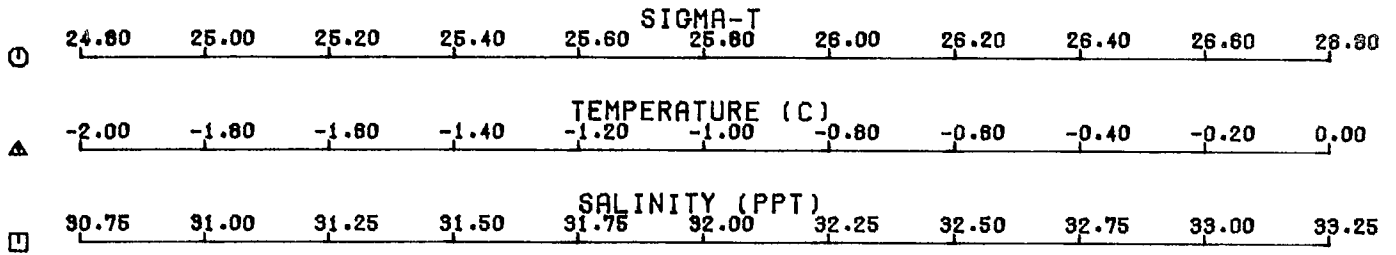

PENNY STRAIT 1976 DATA PROFILES. TENT STATION 14 9 23

LAT 76 38.60 CSTD 803 WATER DEPTH 260.0
 LONG 97 23.30 ICE 2.0 TIME (G.M.T.) 0000
 DATE 17 4 1976

DEPTH	SAL	TEMP	SIGMAT	SOUND
2.0	31.35	-1.74	23.24	1436.1
5.0	31.38	-1.72	23.26	1436.3
10.0	31.38	-1.72	23.26	1436.4
15.0	31.42	-1.70	23.29	1436.6
20.0	31.42	-1.70	23.29	1436.7
25.0	31.42	-1.70	23.29	1436.8
30.0	31.42	-1.70	23.29	1436.8
35.0	31.43	-1.66	23.30	1437.0
40.0	31.48	-1.66	23.35	1437.2
45.0	31.48	-1.66	23.35	1437.3
50.0	31.52	-1.63	23.37	1437.5
55.0	31.53	-1.59	23.38	1437.8
60.0	31.81	-1.37	23.60	1439.4
70.0	31.91	-1.26	23.68	1440.3
80.0	31.97	-1.25	23.73	1440.5
90.0	31.98	-1.21	23.74	1440.5
100.0	32.04	-1.21	23.78	1441.0
125.0	32.35	-1.04	23.83	1442.0
155.0	32.56	-0.86	23.91	1444.4
183.0	32.62	-0.82	23.92	1445.2
210.0	32.77	-0.75	23.93	1446.2

PENNY STRAIT 1976 DATA PROFILES. TENT STATION 14 10 24

LAT 76 38.60 CSTD 803 WATER DEPTH 260.0
 LONG 97 23.80 ICE 2.0 TIME (G.M.T.) 0100
 DATE 17 4 1976

DEPTH	SAL	TEMP	SIGMAT	SOUND
2.0	31.35	-1.75	23.24	1436.1
5.0	31.38	-1.72	23.26	1436.3
10.0	31.38	-1.72	23.26	1436.4
15.0	31.39	-1.68	23.27	1436.7
20.0	31.39	-1.66	23.27	1436.7
25.0	31.43	-1.66	23.30	1437.0
30.0	31.43	-1.66	23.30	1437.0
35.0	31.48	-1.66	23.35	1437.2
40.0	31.52	-1.63	23.37	1437.5
45.0	31.55	-1.61	23.40	1437.7
50.0	31.85	-1.41	23.64	1439.2
60.0	31.90	-1.30	23.68	1439.9
70.0	31.91	-1.26	23.68	1440.3
80.0	31.97	-1.26	23.73	1440.5
90.0	32.04	-1.21	23.78	1441.0
100.0	32.07	-1.19	23.81	1441.3
125.0	32.45	-0.97	23.81	1443.3
150.0	32.57	-0.86	23.90	1444.4
183.0	32.68	-0.77	23.92	1445.5
210.0	32.75	-0.73	23.93	1446.2

PENNY STRAIT

STATION 14 9 23

0000 GMT 17 4 1976 ICE= 2.0

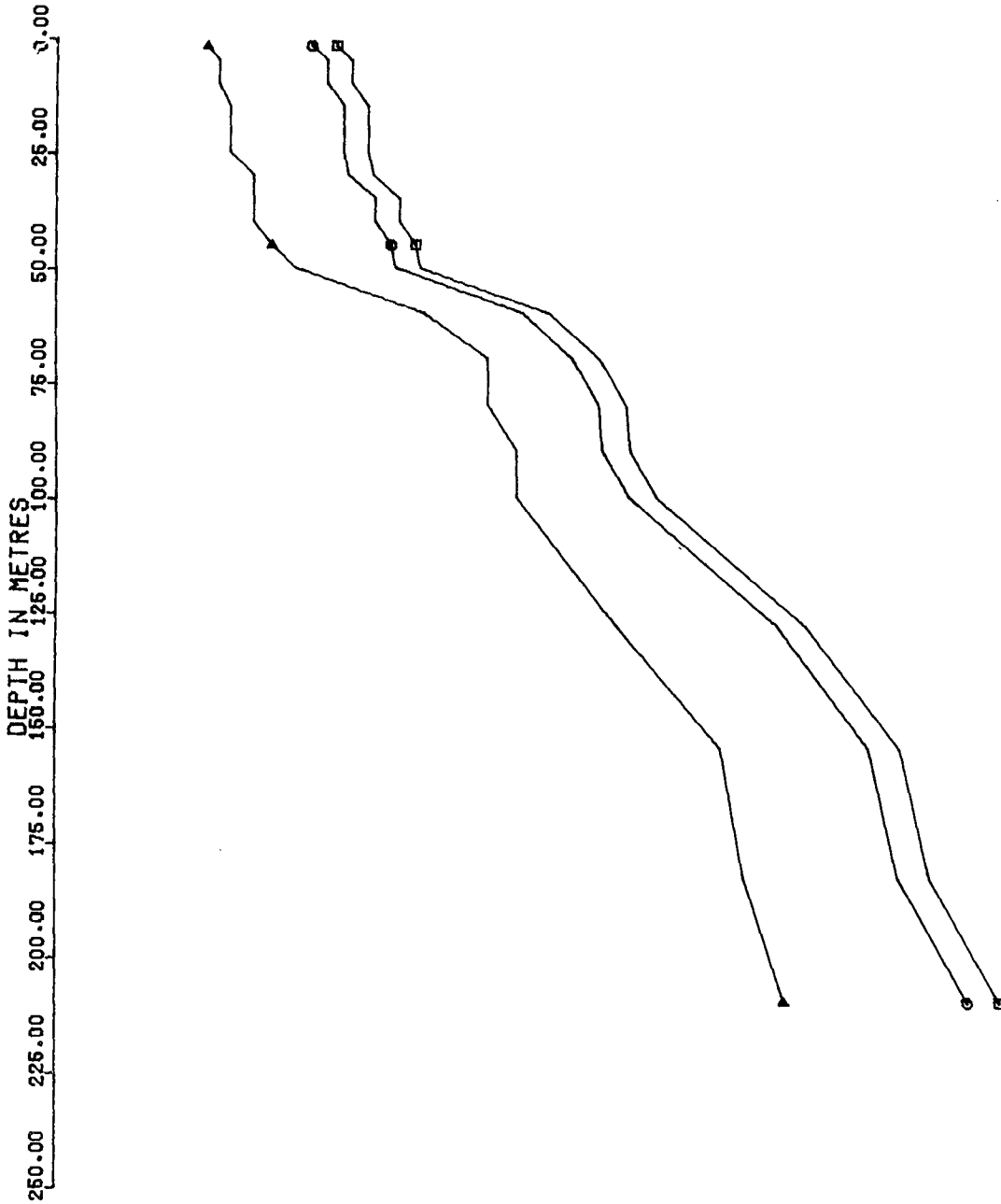
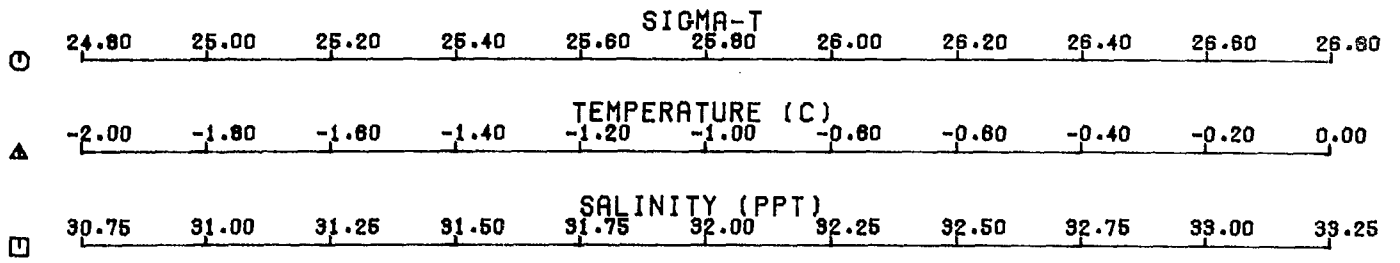

PENNY STRAIT

STATION 14 10 24

0100 GMT 17 4 1976 ICE= 2.0

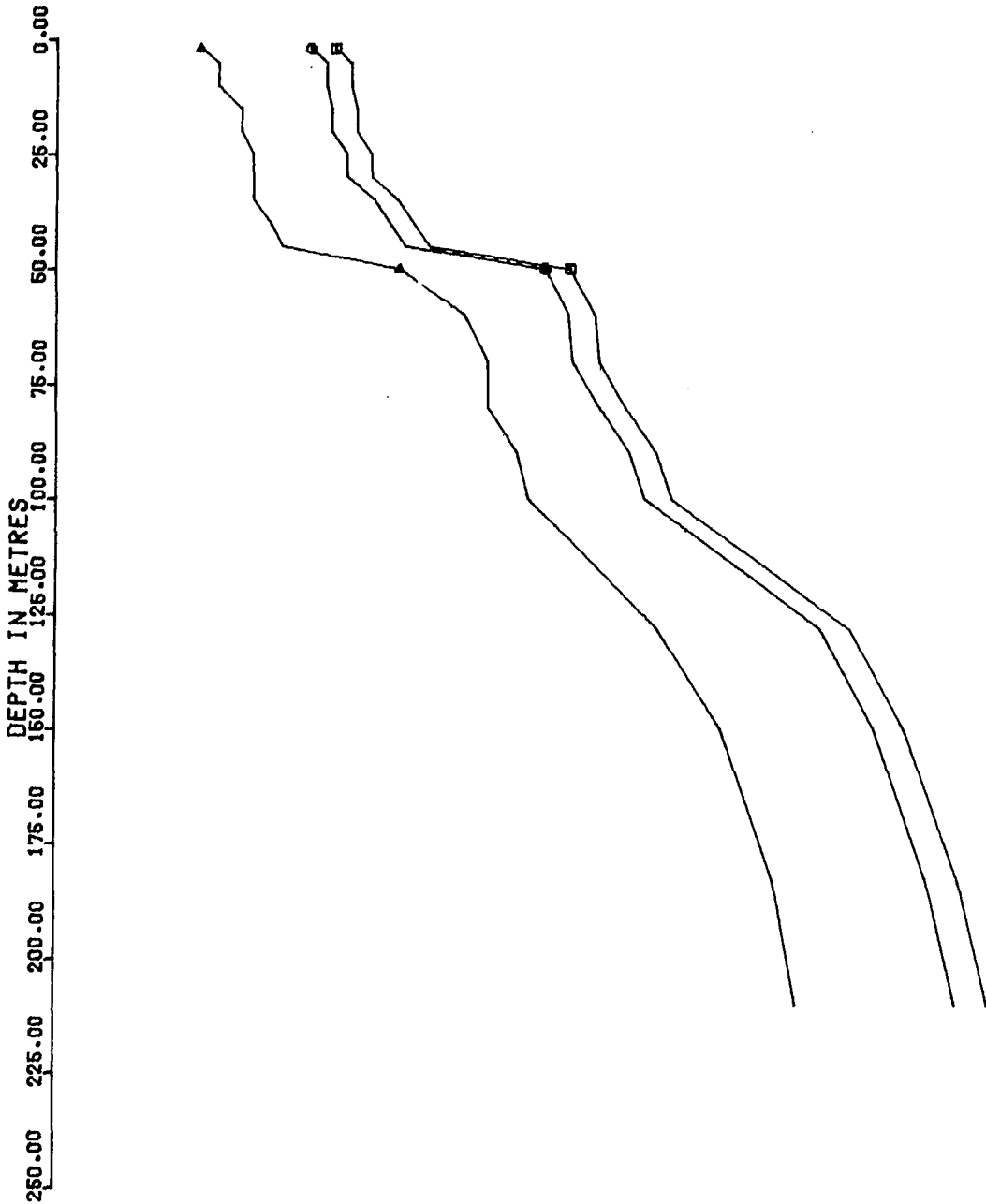
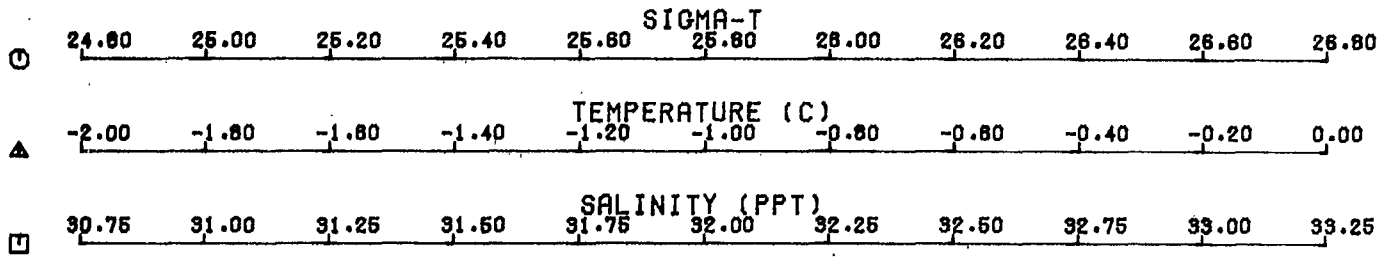

PENNY STRAIT 1976 DATA PROFILES. TENT STATION 14 11 25

LAT 75 38.60 CSTD 803 WATER DEPTH 260.0
 LONG 97 23.80 ICE 2.0 TIME (G.M.T.) 0200
 DATE 17 4 1976

DEPTH	SAL	TEMP	SIGMAT	SOUND
2.0	31.41	-1.74	25.28	1436.2
5.0	31.41	-1.74	25.28	1436.2
10.0	31.42	-1.70	25.29	1436.5
15.0	31.45	-1.68	25.32	1436.7
20.0	31.45	-1.68	25.32	1436.8
25.0	31.49	-1.66	25.35	1437.1
30.0	31.52	-1.63	25.37	1437.3
35.0	31.53	-1.59	25.38	1437.5
40.0	31.65	-1.55	25.46	1438.0
45.0	31.64	-1.38	25.63	1439.3
50.0	31.67	-1.32	25.65	1439.6
60.0	31.87	-1.26	25.73	1440.1
80.0	32.01	-1.24	25.76	1440.7
100.0	32.11	-1.13	25.84	1441.7
105.0	32.14	-1.10	25.87	1441.9
120.0	32.42	-0.99	26.00	1443.2
150.0	32.52	-0.93	26.16	1444.1
183.0	32.65	-0.79	26.27	1445.4
210.0	32.79	-0.66	26.37	1446.6

PENNY STRAIT 1976 DATA PROFILES. TENT STATION 14 12 26

LAT 75 38.60 CSTD 803 WATER DEPTH 260.0
 LONG 97 23.80 ICE 2.0 TIME (G.M.T.) 0300
 DATE 17 4 1976

DEPTH	SAL	TEMP	SIGMAT	SOUND
2.0	31.36	-1.70	25.25	1435.3
5.0	31.42	-1.70	25.29	1436.4
10.0	31.43	-1.66	25.30	1436.7
15.0	31.43	-1.66	25.30	1436.8
20.0	31.43	-1.66	25.30	1436.9
25.0	31.45	-1.63	25.32	1436.9
30.0	31.45	-1.58	25.32	1437.0
35.0	31.45	-1.68	25.32	1437.1
40.0	31.45	-1.68	25.32	1437.1
45.0	31.56	-1.57	25.41	1437.9
50.0	31.60	-1.55	25.43	1438.1
60.0	31.81	-1.37	25.60	1439.4
70.0	31.91	-1.26	25.68	1440.3
80.0	32.01	-1.19	25.75	1440.9
90.0	32.14	-1.10	25.87	1441.7
100.0	32.32	-1.06	26.01	1442.3
120.0	32.39	-0.97	26.07	1443.3
150.0	32.52	-0.88	26.17	1444.3
183.0	32.59	-0.84	26.22	1445.0
210.0	32.76	-0.68	26.35	1446.5

PENNY STRAIT

STATION 14.11.25

0200 GMT 17 4 1976 ICE= 2.0

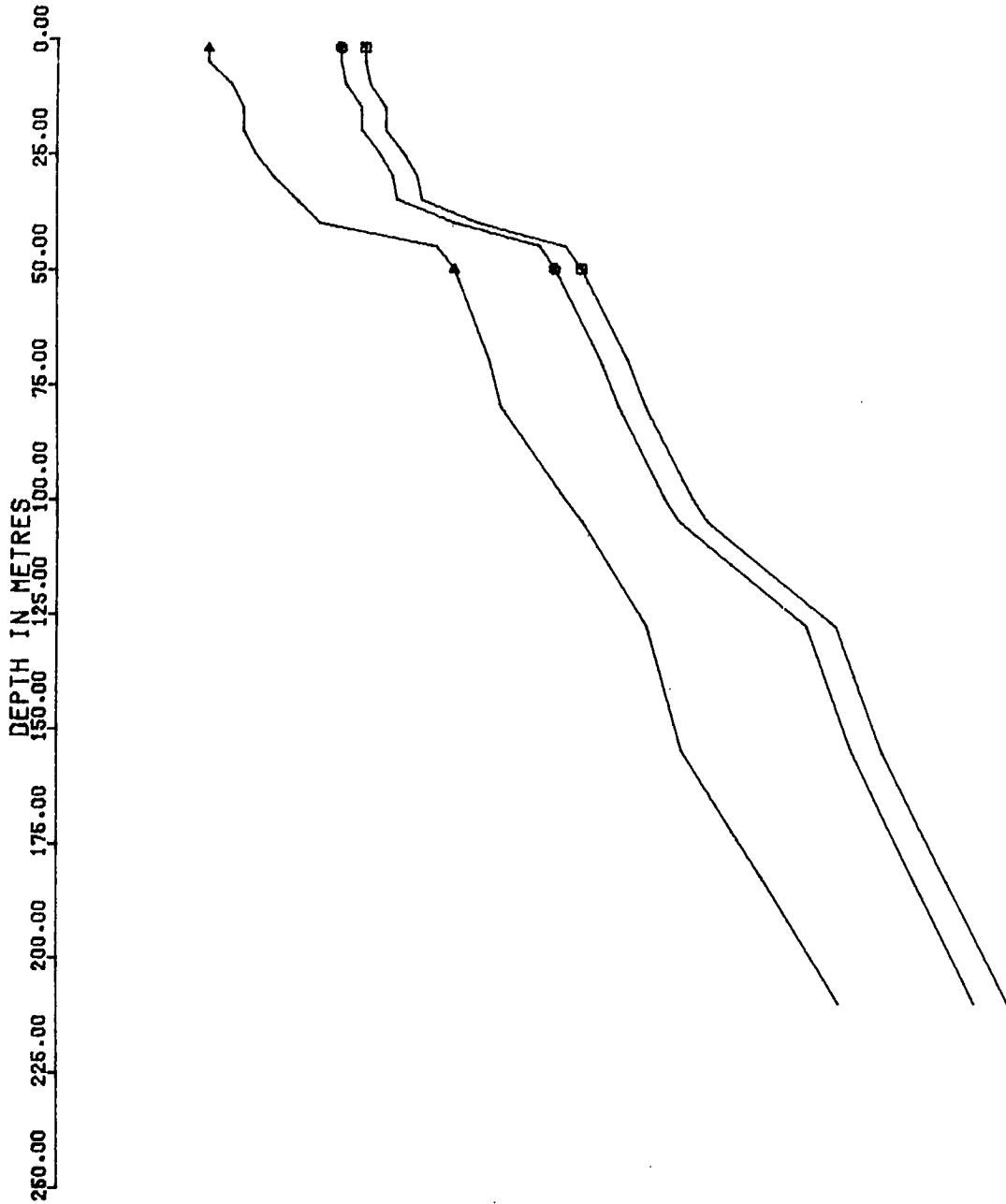
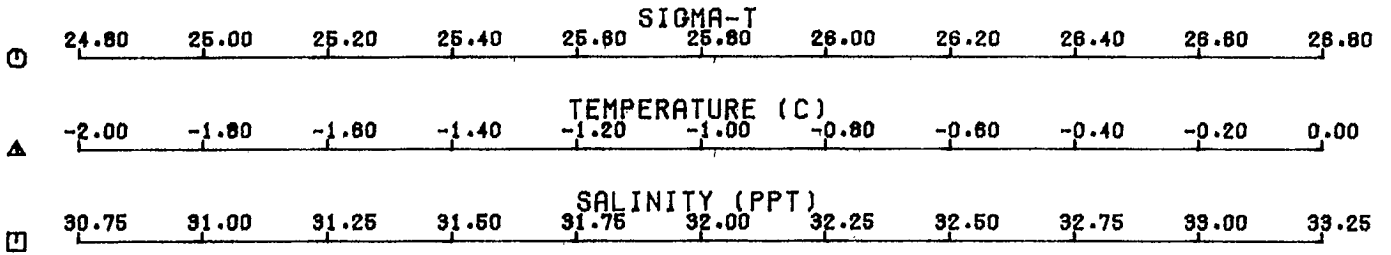

PENNY STRAIT

STATION 14 12 26

0300 GMT 17 4 1976 ICE= 2.0

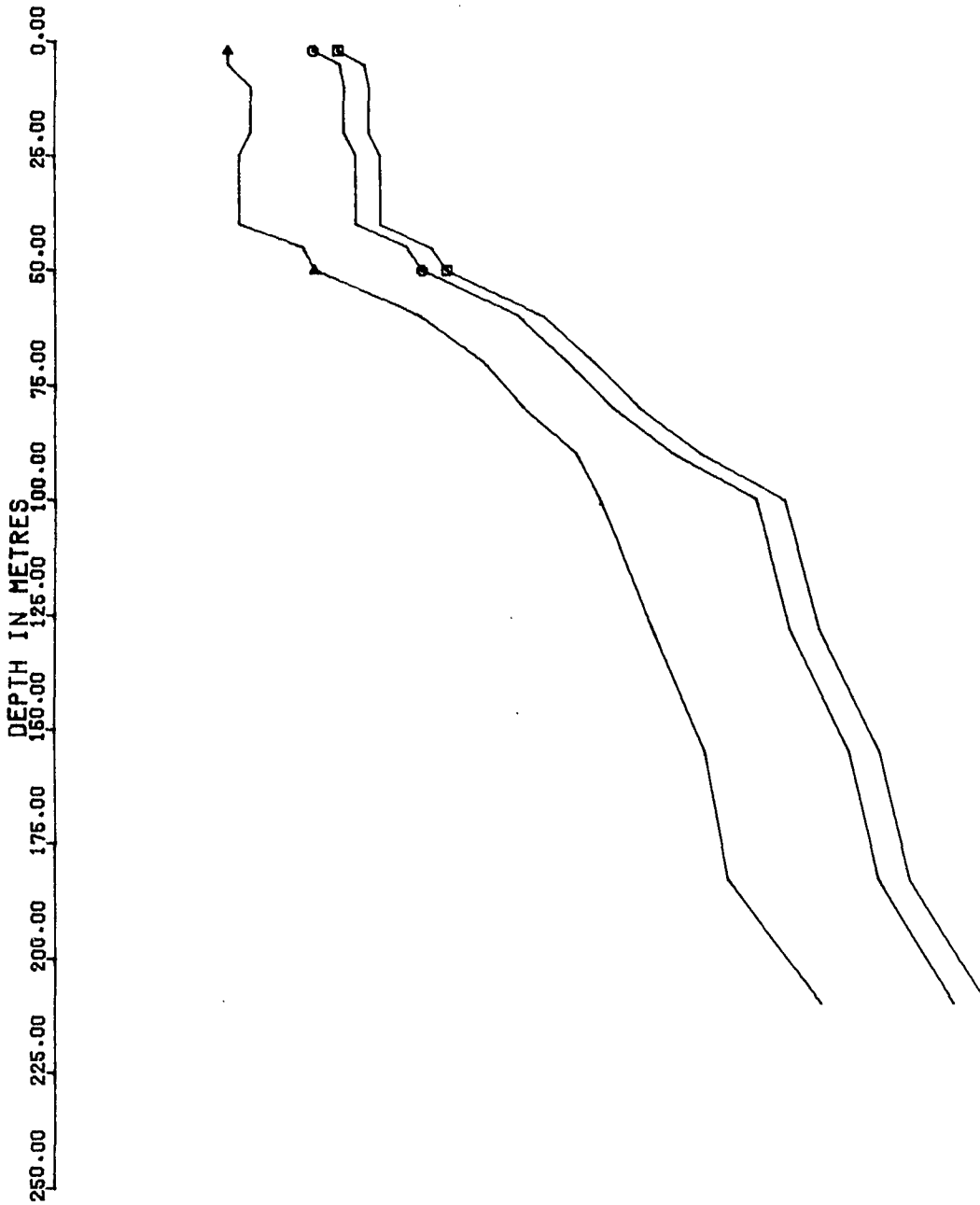
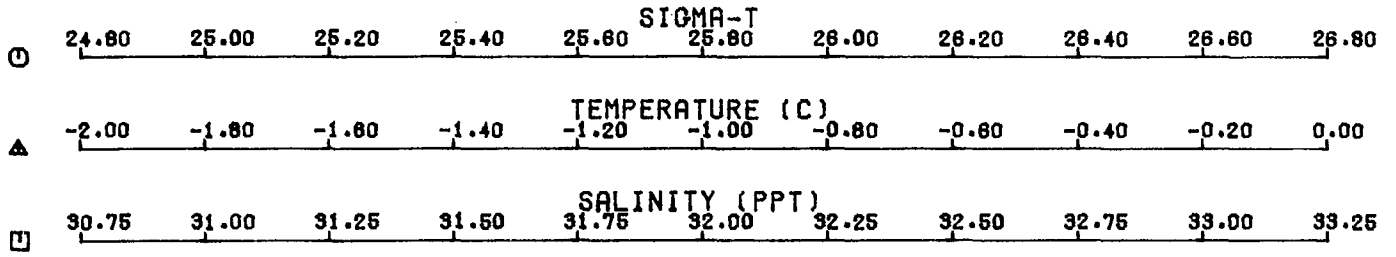

PENNY STRAIT 1976 DATA PROFILES. TENT STATION 1- 13 27
 LAT 76 38.60 CSTD 303 WATER DEPTH 260.0
 LONG 97 23.30 ICE 2.0 TIME (G.M.T.) 0400
 DATE 17 4 1976

DEPTH	SAL	TEMP	SIGMAT	SOUND
2.0	31.38	-1.72	25.26	1436.2
5.0	31.38	-1.72	25.26	1436.3
10.0	31.44	-1.72	25.31	1436.5
15.0	31.44	-1.72	25.31	1436.5
20.0	31.45	-1.68	25.32	1436.8
25.0	31.45	-1.68	25.32	1436.9
30.0	31.52	-1.63	25.37	1437.3
35.0	31.55	-1.61	25.40	1437.5
40.0	31.57	-1.57	25.41	1438.1
45.0	31.61	-1.50	25.44	1438.2
50.0	31.70	-1.43	25.51	1438.5
55.0	31.81	-1.37	25.60	1439.4
60.0	31.90	-1.30	25.68	1440.1
65.0	31.91	-1.26	25.68	1440.4
70.0	31.95	-1.24	25.71	1440.7
75.0	32.01	-1.19	25.76	1441.2
80.0	32.18	-1.08	25.80	1442.4
85.0	32.46	-0.93	26.12	1444.0
90.0	32.56	-0.86	26.10	1444.9
95.0	32.66	-0.77	26.20	1445.9

PENNY STRAIT 1976 DATA PROFILES. TENT STATION 14 14 28
 LAT 76 38.60 CSTD 303 WATER DEPTH 260.0
 LONG 97 23.80 ICE 2.0 TIME (G.M.T.) 0500
 DATE 17 4 1976

DEPTH	SAL	TEMP	SIGMAT	SOUND
2.0	31.42	-1.70	25.29	1436.4
5.0	31.42	-1.70	25.29	1436.4
10.0	31.42	-1.70	25.29	1436.5
15.0	31.45	-1.69	25.32	1436.7
20.0	31.45	-1.68	25.32	1436.8
25.0	31.45	-1.68	25.32	1436.9
30.0	31.51	-1.68	25.37	1437.1
35.0	31.54	-1.66	25.39	1437.3
40.0	31.54	-1.65	25.39	1437.4
45.0	31.55	-1.61	25.40	1437.7
50.0	31.60	-1.55	25.43	1438.1
55.0	31.83	-1.39	25.62	1439.4
60.0	31.88	-1.28	25.66	1440.1
65.0	31.95	-1.24	25.71	1440.6
70.0	31.99	-1.22	25.74	1440.9
75.0	32.01	-1.19	25.76	1441.2
80.0	32.30	-1.04	25.99	1442.8
85.0	32.56	-0.88	26.10	1444.4
90.0	32.56	-0.85	26.10	1444.9
95.0	32.61	-0.68	26.20	1445.7

PENNY STRAIT

STATION 14 13 27

0400 GMT 17 4 1976 ICE= 2.0

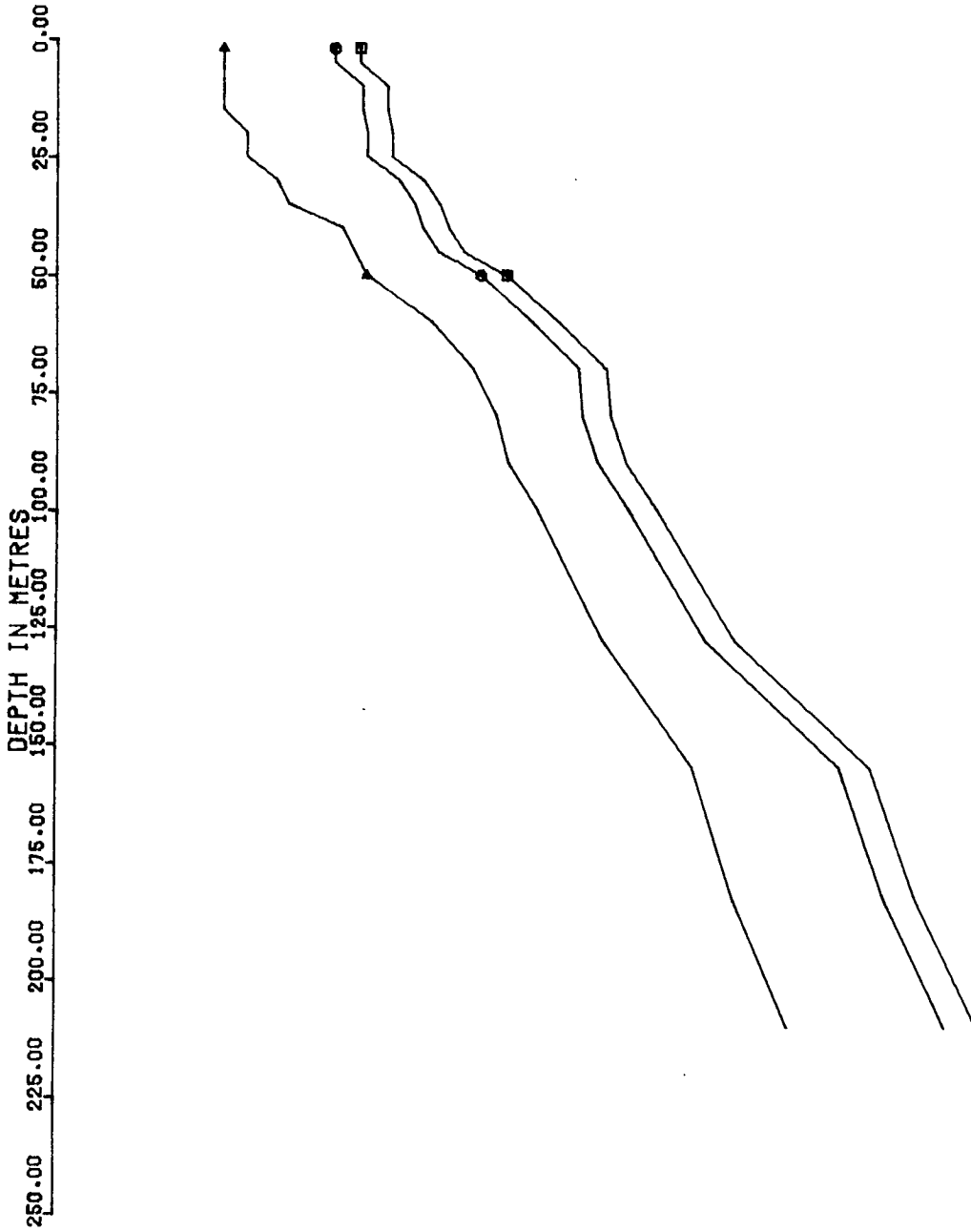
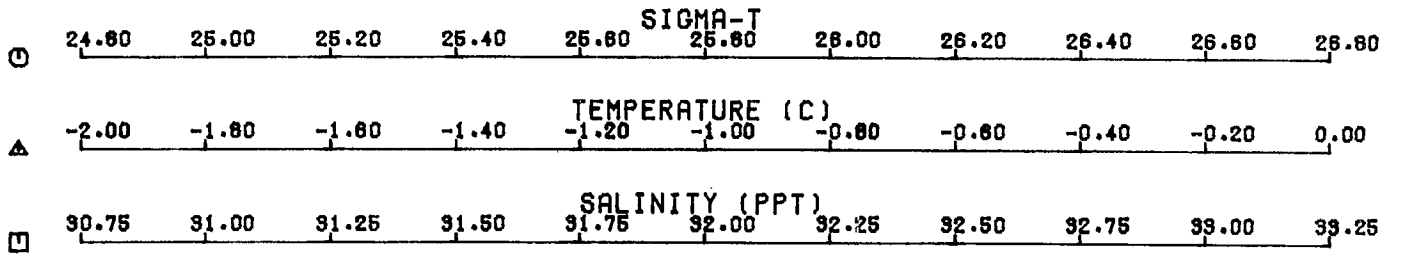

PENNY STRAIT

STATION 14 14 28

0500 GMT 17 4 1976 ICE= 2.0

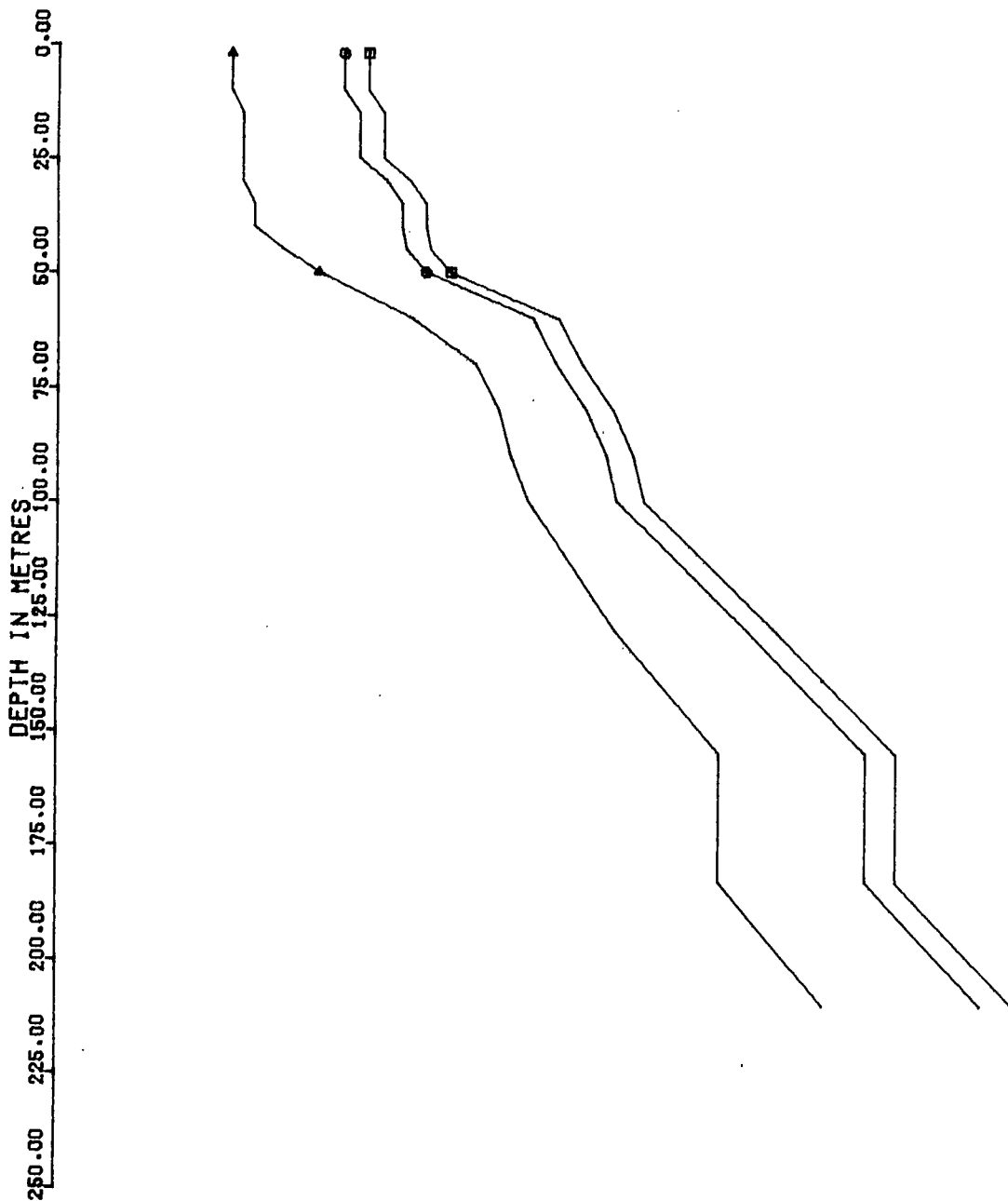
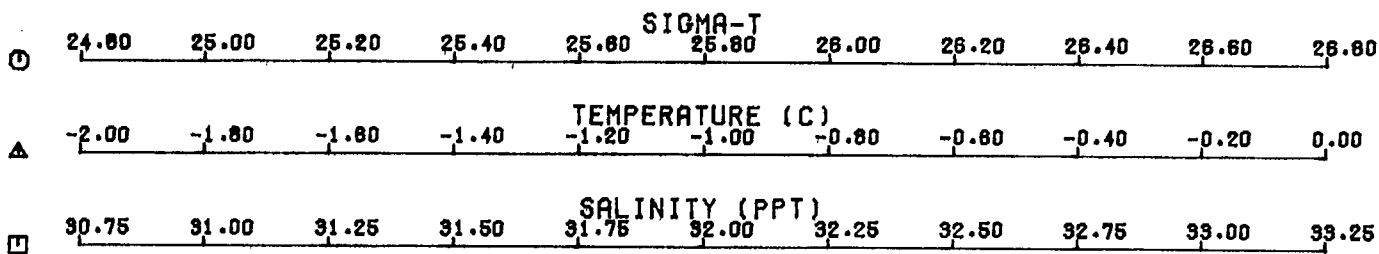

PENNY STRAIT 1976 DATA PROFILES.

OKC

STATION 11 1 23

LAT 76 42.80

CSTD 803

WATER DEPTH 152.0

LONG 96 58.70

ICE 0.8

TIME (G.M.T.) 1530

DATE 13 4 1976

DEPTH	SAL	TEMP	SIGMAT	SOUND
2.0	31.55	-1.50	25.40	1437.5
5.0	31.68	-1.57	25.50	1437.4
10.0	31.68	-1.57	25.50	1437.3
15.0	31.73	-1.57	25.54	1437.7
20.0	31.77	-1.55	25.57	1437.5
25.0	31.78	-1.50	25.58	1438.0
30.0	31.78	-1.50	25.58	1438.3
35.0	31.78	-1.50	25.58	1438.4
40.0	31.78	-1.50	25.58	1438.5
45.0	31.78	-1.50	25.58	1438.5
50.0	31.78	-1.50	25.58	1438.6
60.0	31.78	-1.50	25.58	1438.8
70.0	31.81	-1.48	25.61	1439.1
80.0	31.81	-1.48	25.61	1439.3
90.0	31.84	-1.46	25.63	1439.6
100.0	31.92	-1.37	25.69	1440.3
128.0	32.08	-1.26	25.72	1441.5
155.0	32.16	-1.17	25.88	1442.4
183.0	32.18	-1.19	25.90	1442.8
200.0	32.22	-1.13	25.93	1443.4

PENNY STRAIT 1976 DATA PROFILES.

OKC

STATION 12 15 30

LAT 76 41.50

CSTD 803

WATER DEPTH 187.0

LONG 97 7.00

ICE 0.8

TIME (G.M.T.) 1604

DATE 18 4 1976

DEPTH	SAL	TEMP	SIGMAT	SOUND
2.0	31.51	-1.68	25.37	1436.6
5.0	31.57	-1.63	25.41	1436.7
10.0	31.57	-1.68	25.41	1436.8
15.0	31.57	-1.68	25.41	1436.9
20.0	31.57	-1.68	25.41	1437.0
25.0	31.57	-1.68	25.41	1437.1
30.0	31.57	-1.68	25.41	1437.2
35.0	31.60	-1.66	25.44	1437.4
40.0	31.60	-1.66	25.44	1437.5
45.0	31.60	-1.66	25.44	1437.5
50.0	31.70	-1.59	25.52	1438.1
60.0	31.84	-1.46	25.63	1439.1
70.0	31.92	-1.37	25.69	1439.8
80.0	32.07	-1.19	25.81	1441.0
90.0	32.10	-1.17	25.83	1441.3
100.0	32.22	-1.13	25.88	1441.8
126.0	32.41	-1.04	25.98	1443.0
155.0	32.68	-0.82	26.20	1445.8
183.0	32.66	-0.77	26.20	1445.5
200.0	32.72	-0.71	26.32	1445.1

PENNY STRAIT

STATION 11 1 29

1530 GMT 18 4 1976 ICE= 0.8

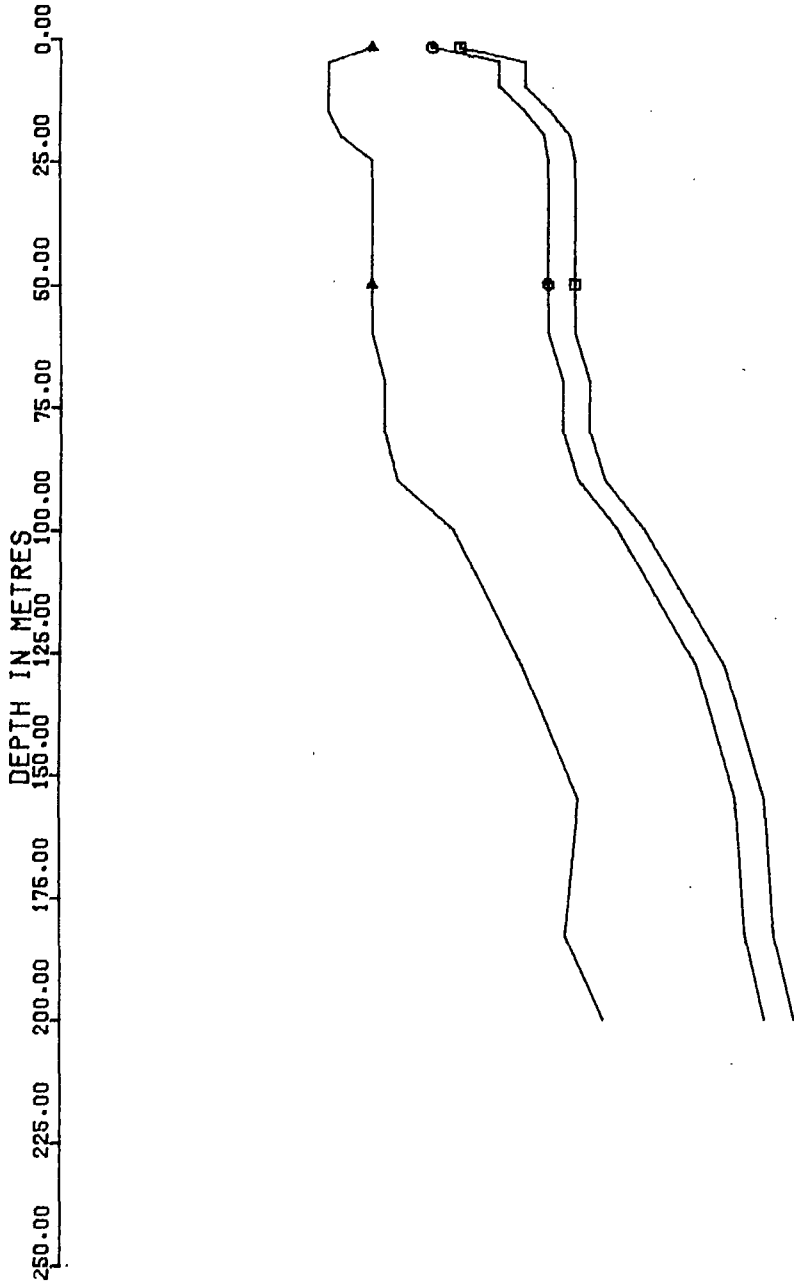
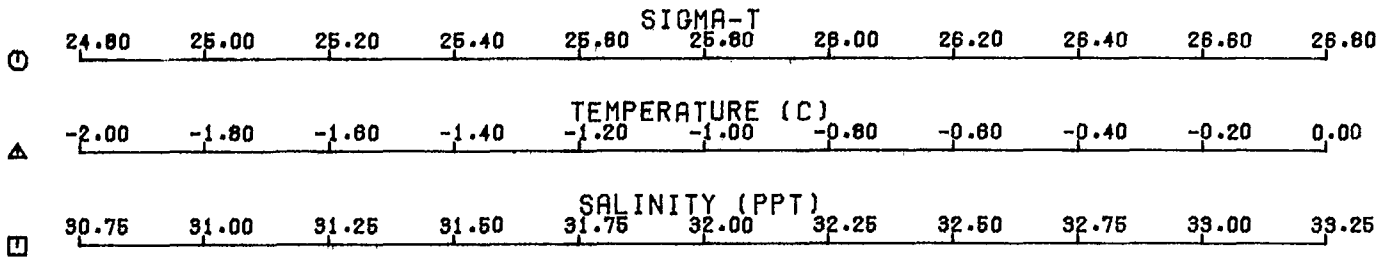

PENNY STRAIT

STATION 12 15 30

1604 GMT 18 4 1976 ICE= 0.8

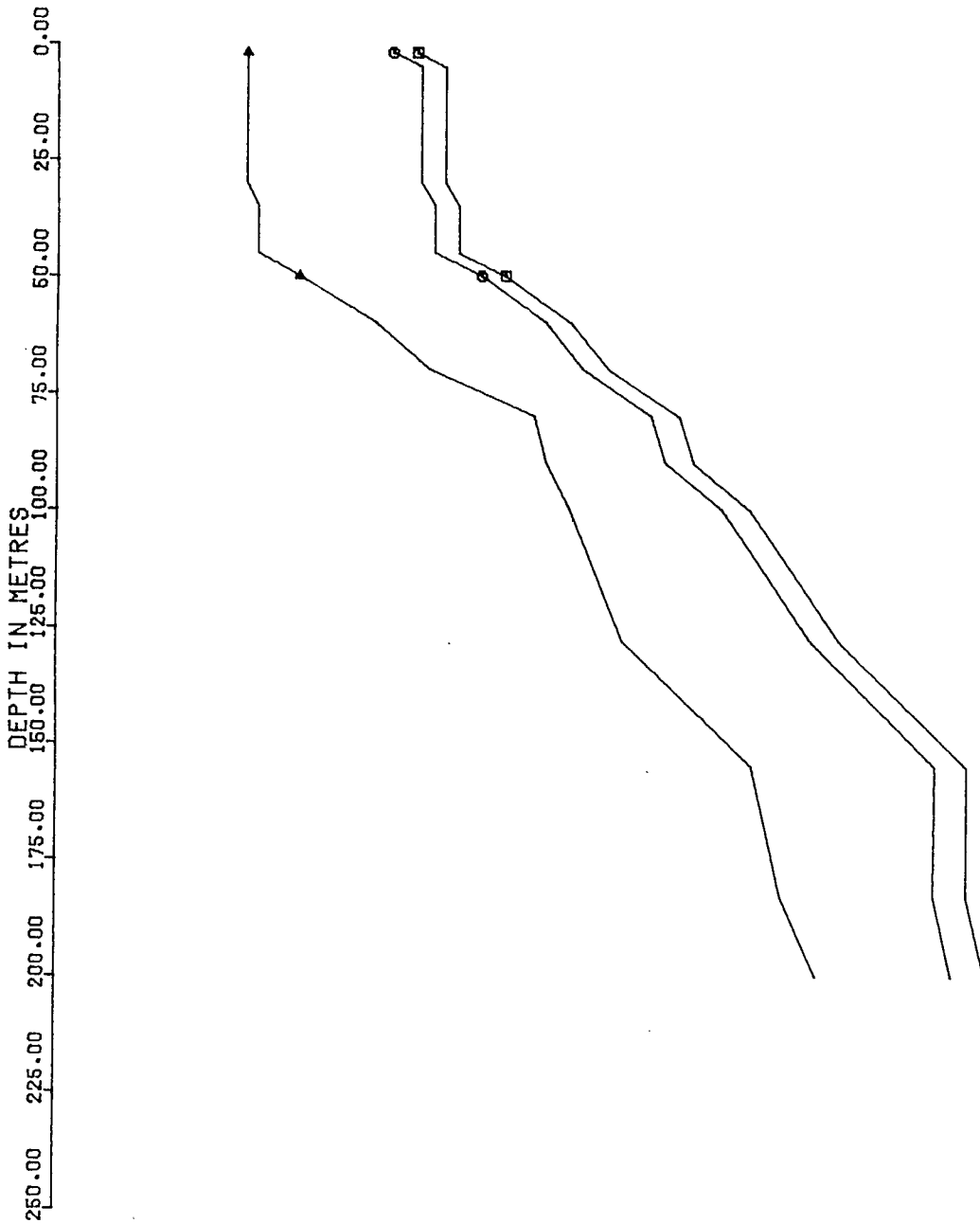
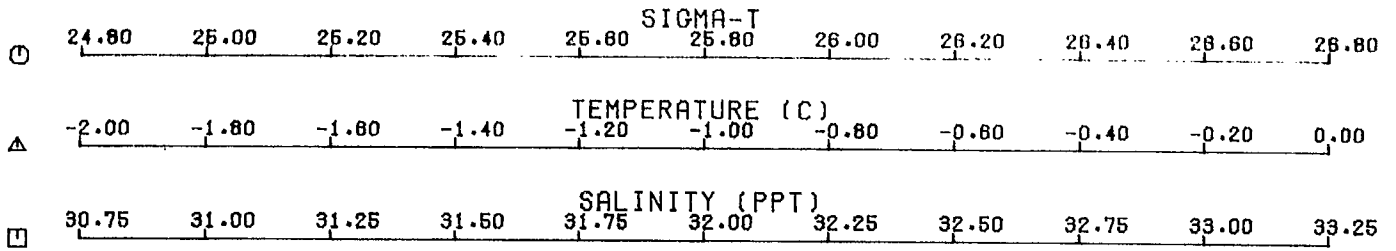

PENNY STRAIT 1976 DATA PROFILES. OKC

STATION 16 1 31

LAT 75 31.40

CSTD 803

WATER DEPTH 225.0

LONG 97 42.80

ICE 0.7

TIME (G.M.T.) 1519

DATE 20 4 1976

DEPTH	SAL	TEMP	SIGMAT	SOUND
2.0	31.22	-1.57	25.13	1436.7
5.0	31.34	-1.57	25.23	1436.9
10.0	31.50	-1.61	25.35	1437.1
15.0	31.50	-1.61	25.35	1437.1
20.0	31.52	-1.63	25.37	1437.2
25.0	31.52	-1.63	25.37	1437.2
30.0	31.52	-1.63	25.37	1437.3
35.0	31.52	-1.63	25.37	1437.4
40.0	31.52	-1.63	25.37	1437.5
45.0	31.55	-1.61	25.40	1437.7
50.0	31.55	-1.61	25.40	1437.8
60.0	31.64	-1.48	25.47	1438.7
70.0	31.73	-1.46	25.54	1439.1
80.0	31.76	-1.44	25.55	1439.4
90.0	31.76	-1.44	25.56	1439.5
100.0	31.76	-1.33	25.66	1439.6
128.0	31.83	-1.39	25.72	1440.5
135.0	31.84	-1.35	25.63	1441.1
183.0	31.87	-1.32	25.68	1441.8
210.0	32.04	-1.21	25.79	1443.0

PENNY STRAIT 1976 DATA PROFILES. OKC

STATION 15 1 32

LAT 76 36.30

CSTD 803

WATER DEPTH 108.0

LONG 97 28.60

ICE 0.7

TIME (G.M.T.) 1619

DATE 20 4 1976

DEPTH	SAL	TEMP	SIGMAT	SOUND
2.0	31.48	-1.66	25.34	1436.7
5.0	31.52	-1.63	25.37	1436.9
10.0	31.62	-1.57	25.45	1437.4
15.0	31.70	-1.48	25.52	1438.0
20.0	31.80	-1.41	25.60	1438.6
25.0	31.31	-1.37	25.60	1438.9
30.0	31.86	-1.37	25.64	1439.0
35.0	31.90	-1.35	25.68	1439.3
40.0	31.90	-1.35	25.68	1439.3
45.0	31.93	-1.32	25.70	1439.6
50.0	31.93	-1.32	25.70	1439.7
60.0	31.95	-1.24	25.71	1440.3
70.0	32.07	-1.19	25.81	1440.8
80.0	32.06	-1.15	25.82	1441.2
90.0	32.30	-1.04	25.99	1442.2
100.0	32.33	-1.02	26.01	1442.5

PENNY STRAIT

STATION 16 1 31

1519 GMT 20 4 1976 ICE= 0.7

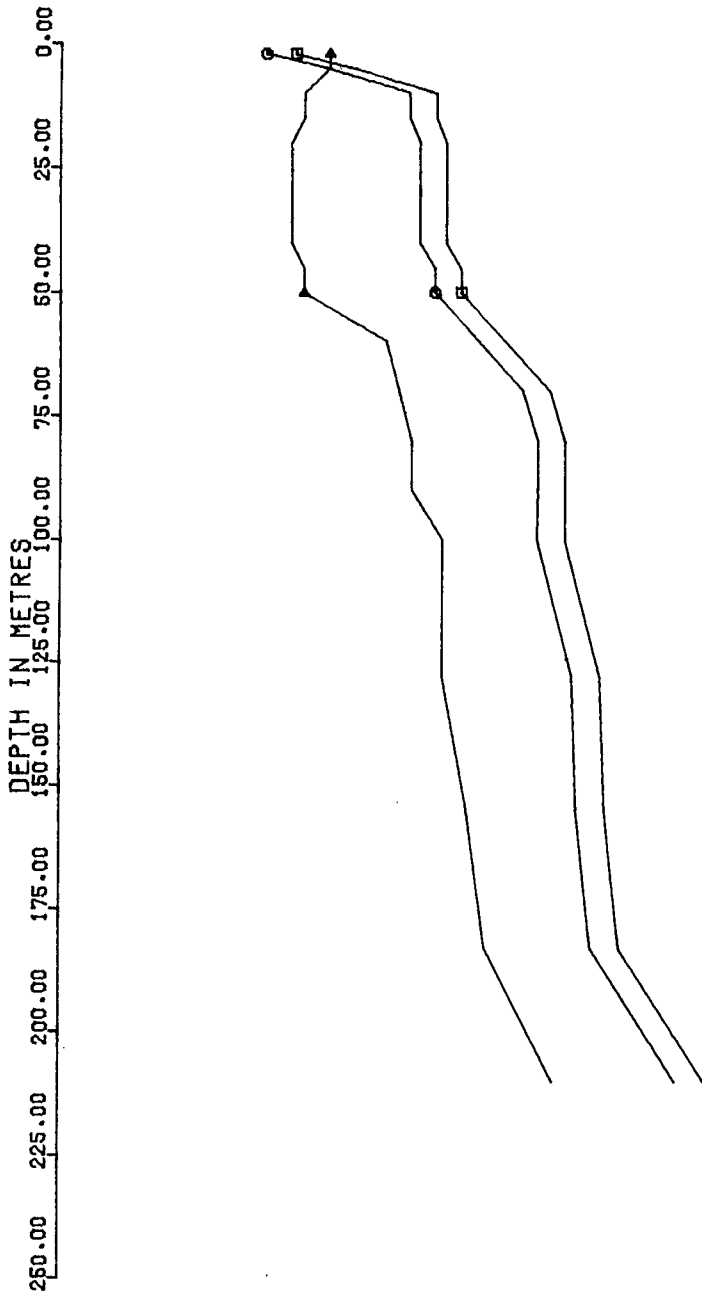
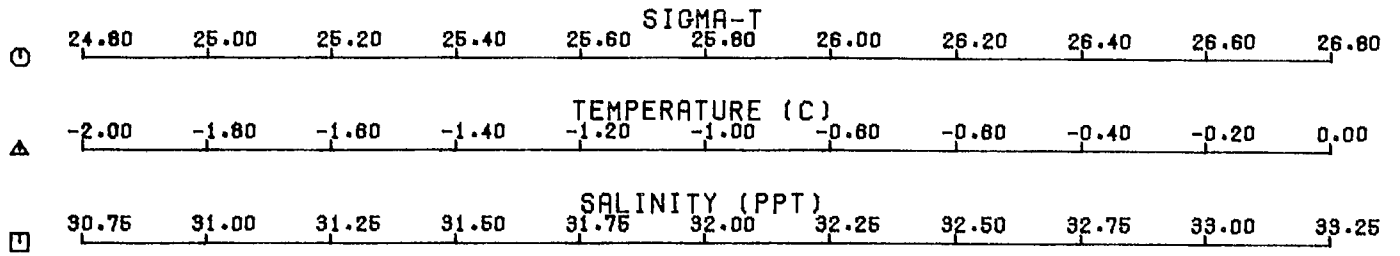

PENNY STRAIT

STATION 15 1 32

1619 GMT 20 4 1976 ICE= 0.7

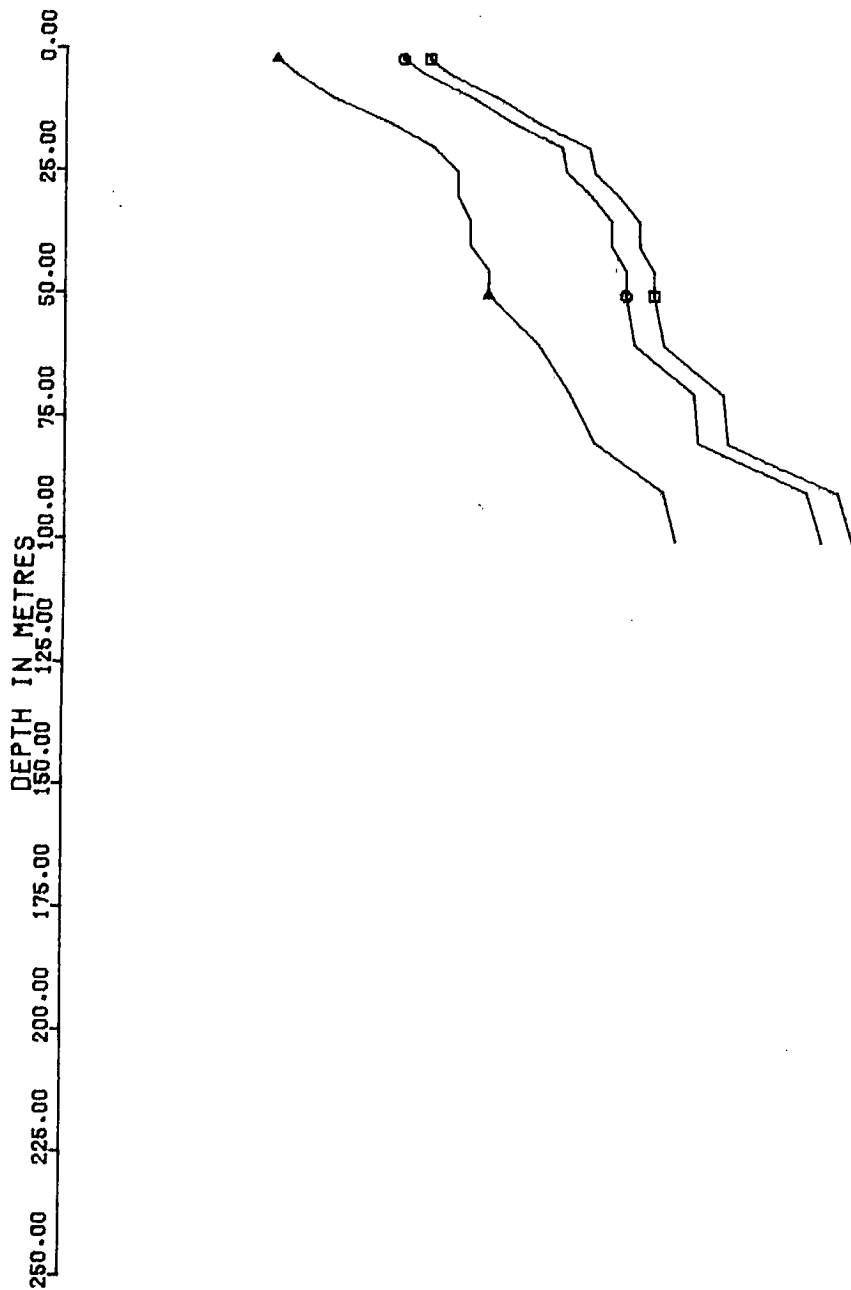
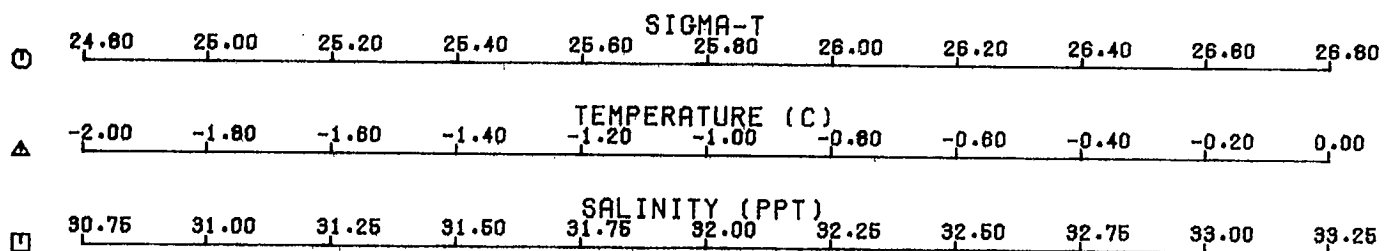

PENNY STRAIT 1976 DATA PROFILES. OKC

STATION 14 15 33

LAT 76 38.60

CSTD 803

WATER DEPTH 260.0

LONG 97 23.80

ICE 2.0

TIME (G.M.T.) 1745

DATE 20 4 1976

DEPTH	SAL	TEMP	SIGMAT	SOUND
2.0	31.34 2	-1.79 2	25.23	1435.8
5.0	31.34 2	-1.79 2	25.23	1435.8
10.0	31.38 2	-1.77 2	25.23	1436.1
15.0	31.41	-1.74	25.20	1436.4
20.0	31.48	-1.66	25.34	1437.0
25.0	31.65	-1.55	25.48	1437.8
30.0	31.81	-1.37	25.60	1439.0
35.0	31.97	-1.26	25.73	1439.8
40.0	31.98	-1.21	25.74	1440.1
45.0	31.98	-1.21	25.74	1440.2
50.0	32.01	-1.19	25.76	1440.4
55.0	32.08	-1.15	25.82	1440.9
60.0	32.11	-1.13	25.84	1441.2
65.0	32.14	-1.10	25.85	1441.5
70.0	32.26	-1.06	25.96	1442.0
75.0	32.32	-1.06	25.99	1442.3
80.0	32.40	-0.97	26.07	1443.3
85.0	32.46	-0.97	26.12	1443.8
90.0	32.58	-0.88	26.21	1444.8
95.0	32.69	-0.73	26.30	1446.1

PENNY STRAIT 1976 DATA PROFILES. OKC

STATION 13 1 34

LAT 76 39.80

CSTD 803

WATER DEPTH 220.0

LONG 97 16.60

ICE 0.7

TIME (G.M.T.) 1819

DATE 20 4 1976

DEPTH	SAL	TEMP	SIGMAT	SOUND
2.0	31.46	-1.77	25.35	1436.2
5.0	31.50	-1.72	25.36	1436.5
10.0	31.56	-1.72	25.41	1436.6
15.0	31.56	-1.72	25.41	1436.7
20.0	31.60	-1.66	25.44	1437.1
25.0	31.66	-1.50	25.48	1438.1
30.0	31.73	-1.46	25.54	1438.4
35.0	31.76	-1.44	25.56	1438.6
40.0	31.80 2	-1.41	25.60	1438.9
45.0	31.90	-1.35	25.68	1439.4
50.0	31.95	-1.24	25.71	1440.1
55.0	31.98	-1.21	25.74	1440.4
60.0	32.07	-1.19	25.81	1440.8
65.0	32.10	-1.17	25.83	1441.1
70.0	32.20	-1.10	25.91	1441.8
75.0	32.39	-1.02	26.06	1442.6
80.0	32.46	-0.93	26.12	1443.5
85.0	32.62	-0.83	26.24	1444.7
90.0	32.68	-0.77	26.29	1445.5
95.0	32.73 2	-0.75	26.33	1446.1

PENNY STRAIT

STATION 14 15 33

1745 GMT 20 4 1976 ICE= 2.0

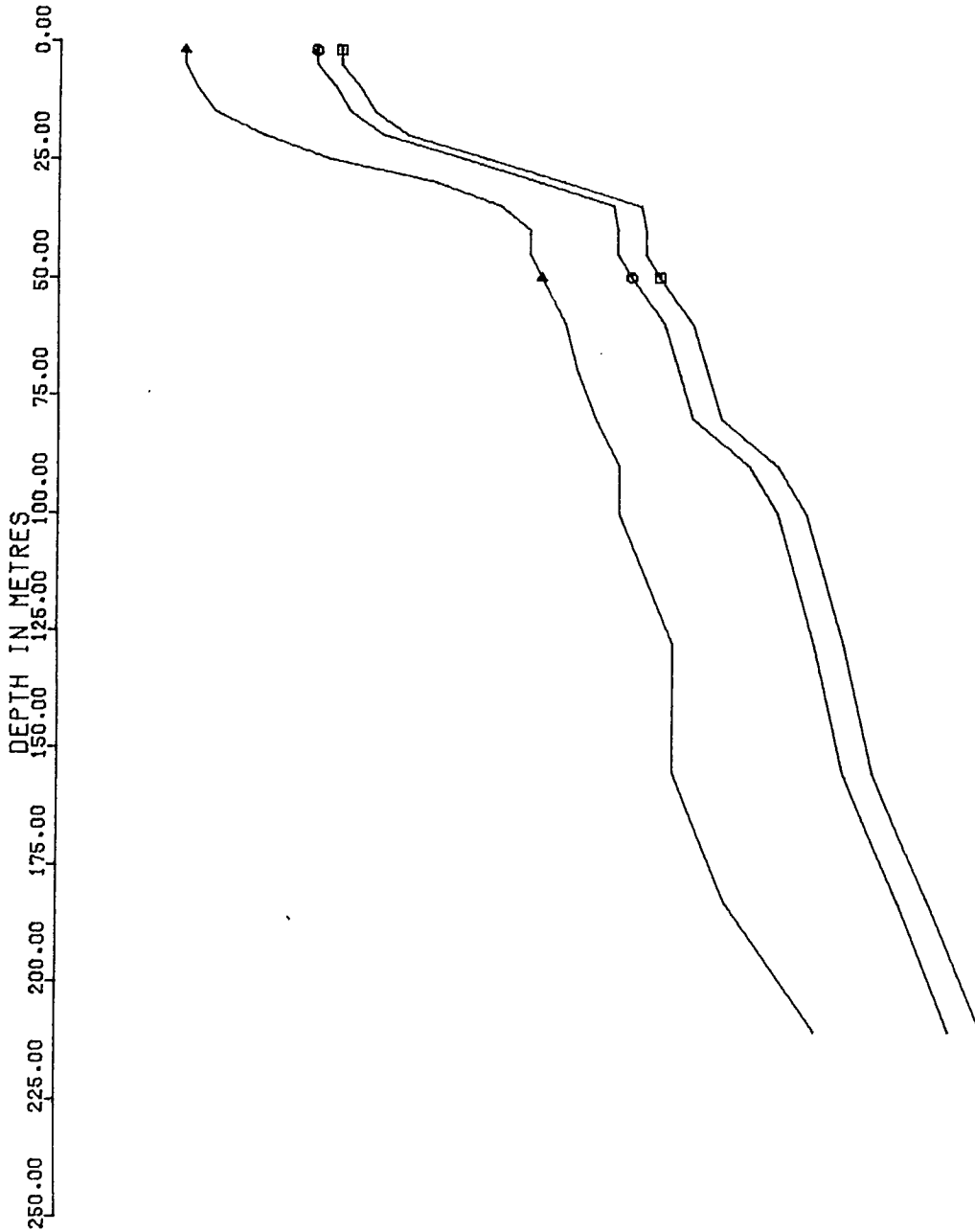
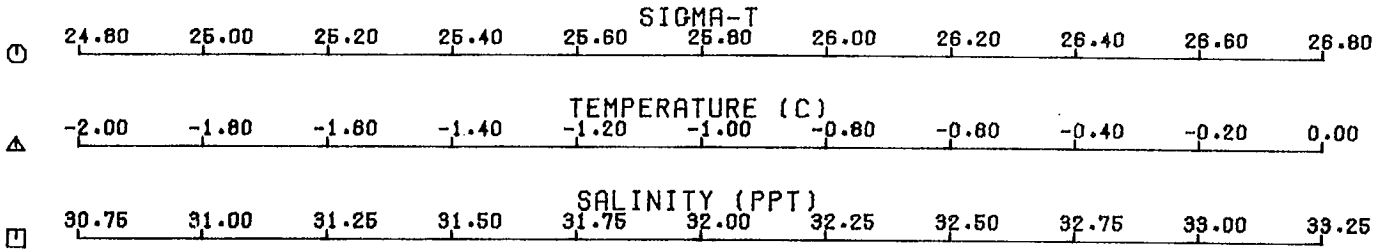

PENNY STRAIT

STATION 13 1 34

1819 GMT 20 4 1976 ICE= 0.7

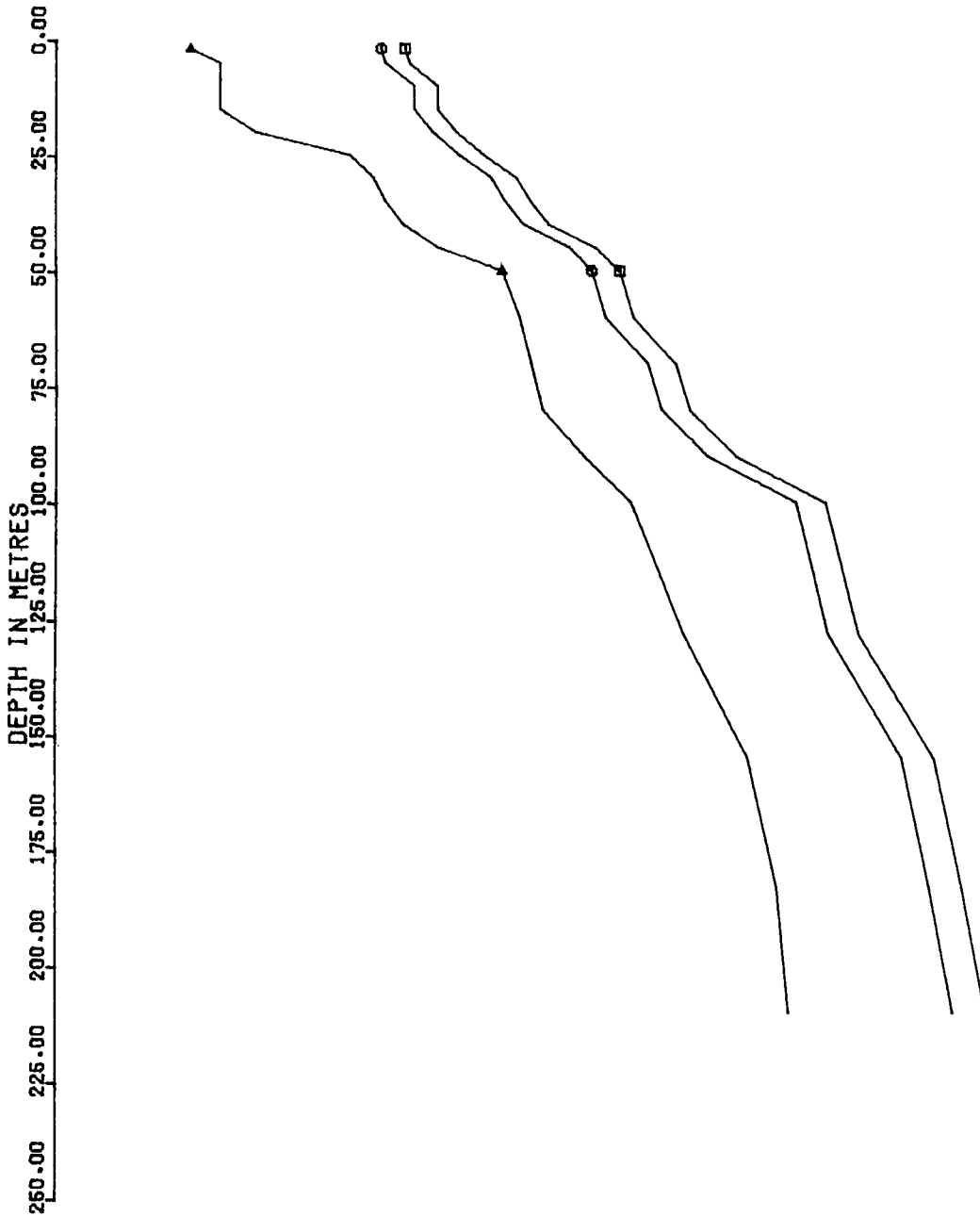
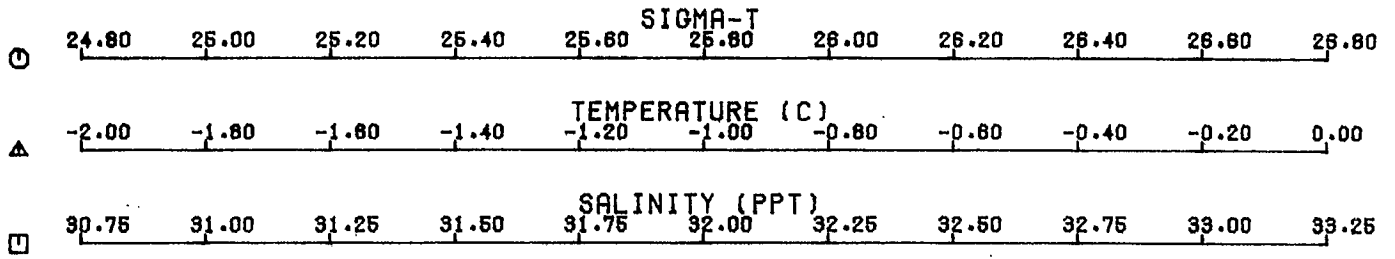

PENNY STRAIT 1976 DATA PROFILES. OKC STATION 12 16 35

LAT 76 41.50 CSTD 803 WATER DEPTH 187.0
 LONG 37 7.09 ICE 0.8 TIME (G.M.T.) 1855
 DATE 20 4 1976

DEPTH	SAL	TEMP	SIGMAT	SOUND
2.0	31.855	-1.70	25.46	1436.7
5.0	31.855 2	-1.70 2	25.46	1436.3
10.0	31.866	-1.66	25.49	1437.0
15.0	31.899	-1.63	25.51	1437.3
20.0	31.72 2	-1.61	25.54	1437.5
25.0	31.72	-1.61	25.54	1437.6
30.0	31.72	-1.61	25.54	1437.7
35.0	31.766	-1.59	25.57	1437.9
40.0	31.766	-1.59	25.57	1438.0
45.0	31.766	-1.57	25.59	1438.2
50.0	31.83 2	-1.55	25.62	1438.5
60.0	31.87	-1.48	25.65	1439.0
70.0	32.08	-1.39	25.82	1440.3
80.0	32.13	-1.19	25.86	1441.1
90.0	32.31	-1.10	25.80	1441.5
100.0	32.32	-1.06	25.81	1442.3
120.0	32.46	-0.93	25.12	1443.5
150.0	32.52	-0.83	26.16	1444.1
183.0	32.52	-0.83	26.16	1444.8

PENNY STRAIT 1976 DATA PROFILES. OKC STATION 11 2 36

LAT 76 42.80 CSTD 803 WATER DEPTH 192.0
 LONG 36 58.70 ICE 0.8 TIME (G.M.T.) 1930
 DATE 20 4 1976

DEPTH	SAL	TEMP	SIGMAT	SOUND
2.0	31.79	-1.57	25.80	1437.5
5.0	31.86	-1.52	25.85	1437.9
10.0	31.86	-1.52	25.85	1438.0
15.0	31.86	-1.52	25.85	1438.1
20.0	31.86	-1.52	25.85	1438.2
25.0	31.89 2	-1.50	25.87	1438.4
30.0	31.89	-1.50 2	25.87	1438.5
35.0	31.90	-1.46	25.88	1438.7
40.0	31.93	-1.44	25.90	1439.0
50.0	31.97	-1.41	25.73	1439.2
60.0	31.98	-1.37	25.74	1439.5
70.0	31.96	-1.32	25.74	1439.9
80.0	32.12	-1.24	25.85	1440.7
90.0	32.15	-1.21	25.87	1441.0
100.0	32.15	-1.21	25.87	1441.2
120.0	32.22	-1.13	25.83	1442.3
150.0	32.31	-1.10	25.80	1443.0
183.0	32.38	-1.06	26.06	1443.7

PENNY STRAIT

STATION 12 16 35

1855 GMT 20 4 1976 ICE= 0.8

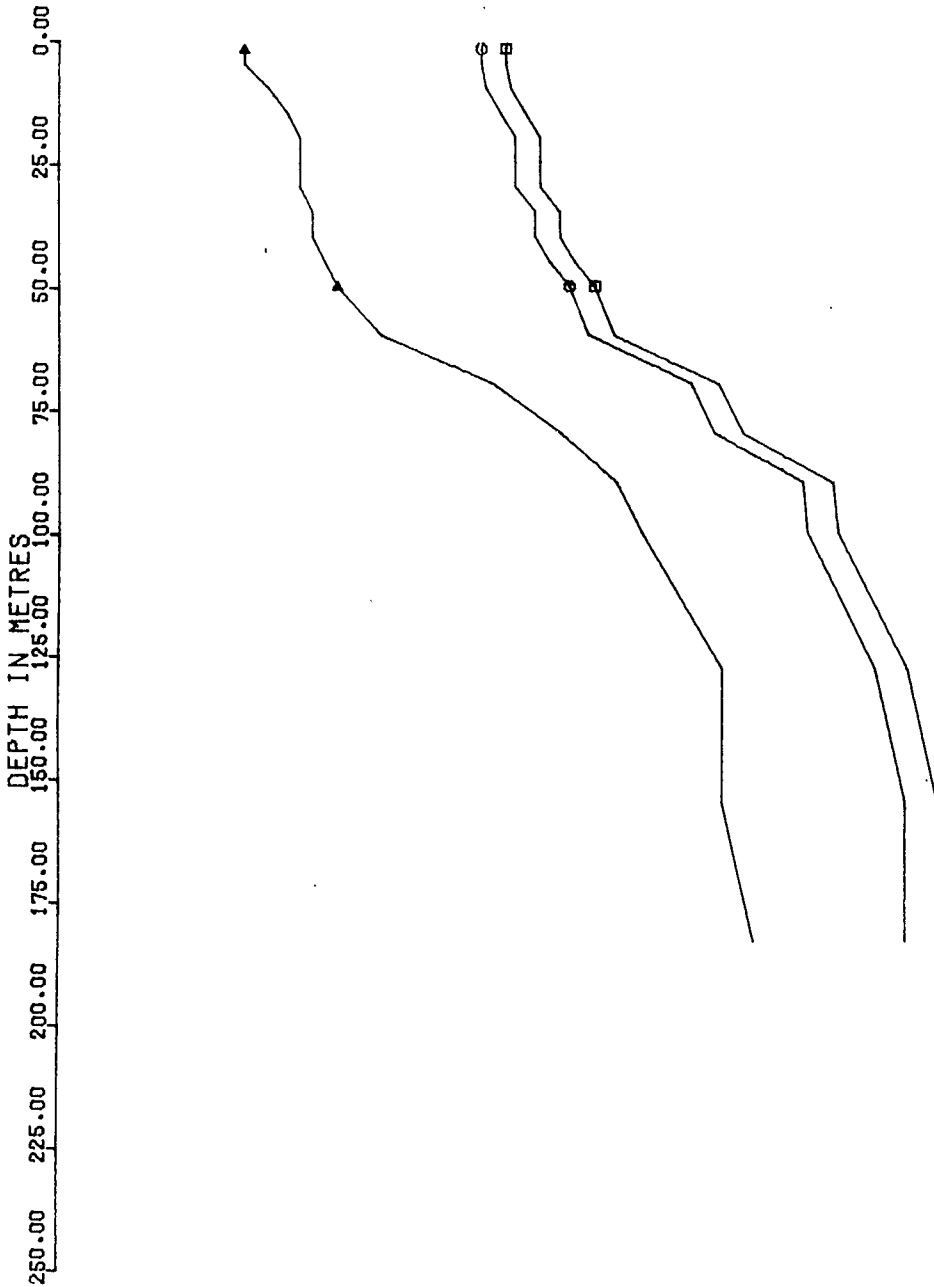
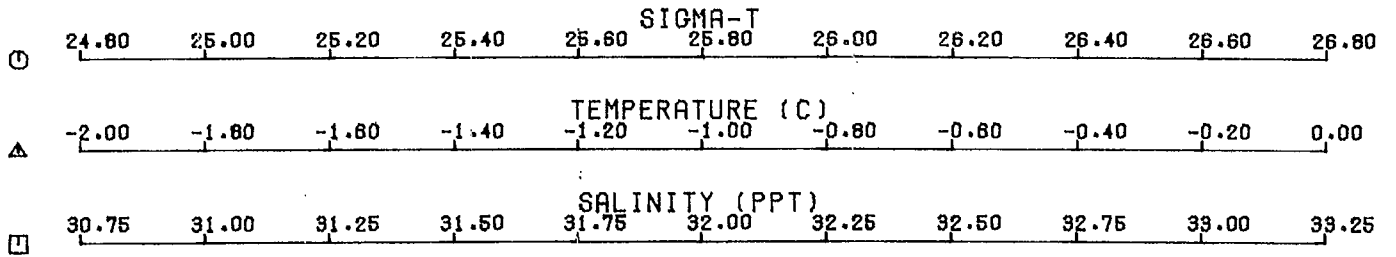

PENNY STRAIT STATION 11 2 36 1930 GMT 20 4 1976 ICE= 0.8

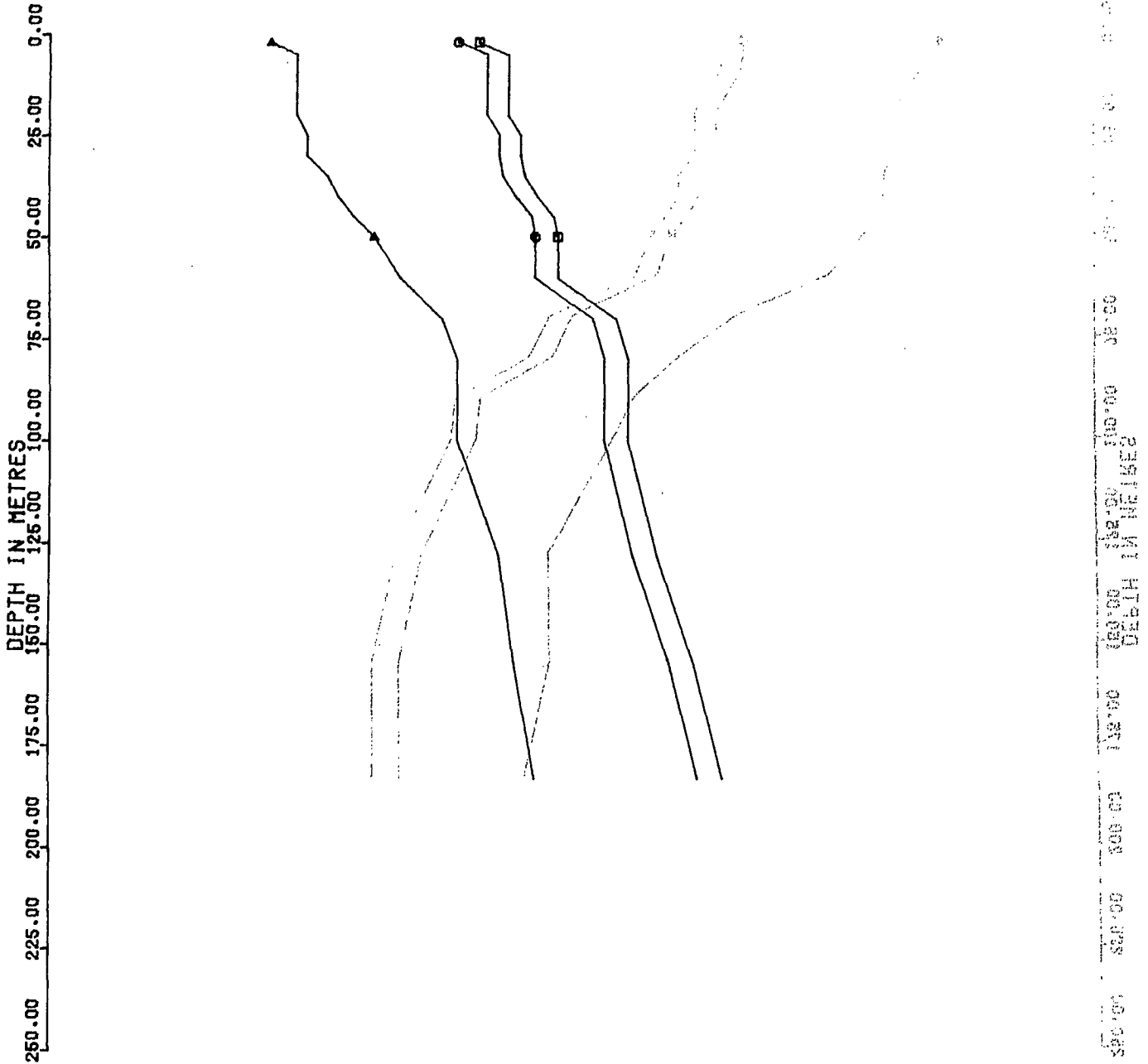
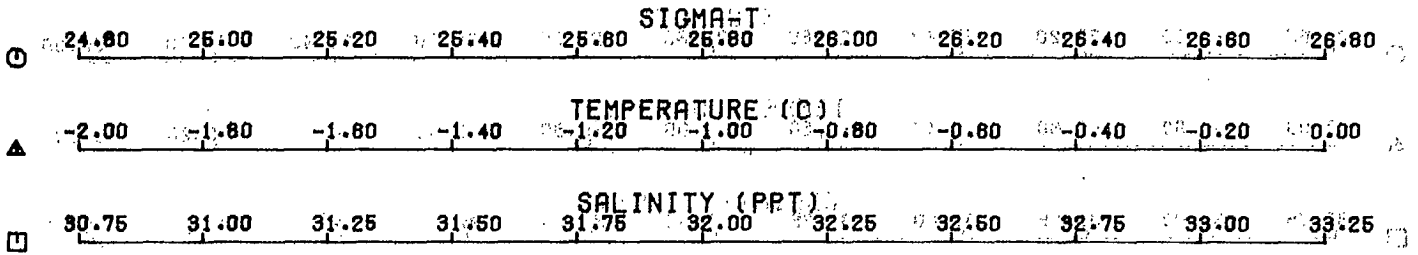

PENNY STRAIT 1976 DATA PROFILES.

OKC

STATION 15 2 37

LAT 76 31.40

CSTD 803

WATER DEPTH 225.0

LONG 97 42.80

ICE 0.7

TIME (G.M.T.) 2040

DATE 20 4 1976

DEPTH	SAL	TEMP	SIGMAT	SOUND
2.0	31.42	-1.70	25.29	1436.4
5.0	31.45	-1.68	25.32	1436.6
10.0	31.48	-1.66	25.34	1436.8
15.0	31.48	-1.65	25.34	1436.9
20.0	31.48	-1.66	25.34	1437.0
25.0	31.52	-1.63	25.37	1437.2
30.0	31.52	-1.63	25.37	1437.3
35.0	31.55	-1.61	25.40	1437.5
40.0	31.55	-1.61	25.40	1437.6
45.0	31.55	-1.61	25.40	1437.7
50.0	31.55	-1.61	25.40	1437.8
55.0	31.56	-1.57	25.40	1438.2
60.0	31.62	-1.57	25.45	1438.4
70.0	31.70	-1.46	25.50	1439.3
80.0	31.86	-1.37	25.64	1440.0
90.0	31.90	-1.35	25.68	1440.3
100.0	31.94	-1.28	25.71	1441.2
128.0	32.03	-1.23	25.73	1441.8
155.0	32.04	-1.21	25.79	1442.5
183.0	32.13	-1.19	25.86	1443.2
210.0				

PENNY STRAIT 1976 DATA PROFILES.

OKC

STATION 15 2 38

LAT 76 36.30

CSTD 803

WATER DEPTH 157.0

LONG 97 28.60

ICE 0.6

TIME (G.M.T.) 2115

DATE 20 4 1976

DEPTH	SAL	TEMP	SIGMAT	SOUND
2.0	31.45	-1.68	25.32	1436.5
5.0	31.45	-1.68	25.32	1436.6
10.0	31.51	-1.68	25.37	1436.7
15.0	31.55	-1.68	25.40	1437.0
20.0	31.58	-1.63	25.42	1437.2
25.0	31.50	-1.55	25.44	1437.7
30.0	31.69	-1.35	25.51	1438.1
35.0	31.72	-1.30	25.53	1438.3
40.0	31.72	-1.30	25.53	1438.4
45.0	31.72	-1.30	25.53	1438.5
50.0	31.75	-1.48	25.56	1438.7
55.0	31.90	-1.33	25.66	1439.7
60.0	31.90	-1.35	25.68	1439.8
70.0	32.07	-1.19	25.81	1441.0
80.0	32.11	-1.13	25.84	1441.5
90.0	32.25	-1.08	25.90	1442.1
128.0	32.40	-0.93	26.07	1443.5
155.0	32.52	-0.88	26.14	1444.3

PENNY STRAIT

STATION 16 2 37

2040 GMT 20 4 1976 ICE= 0.7

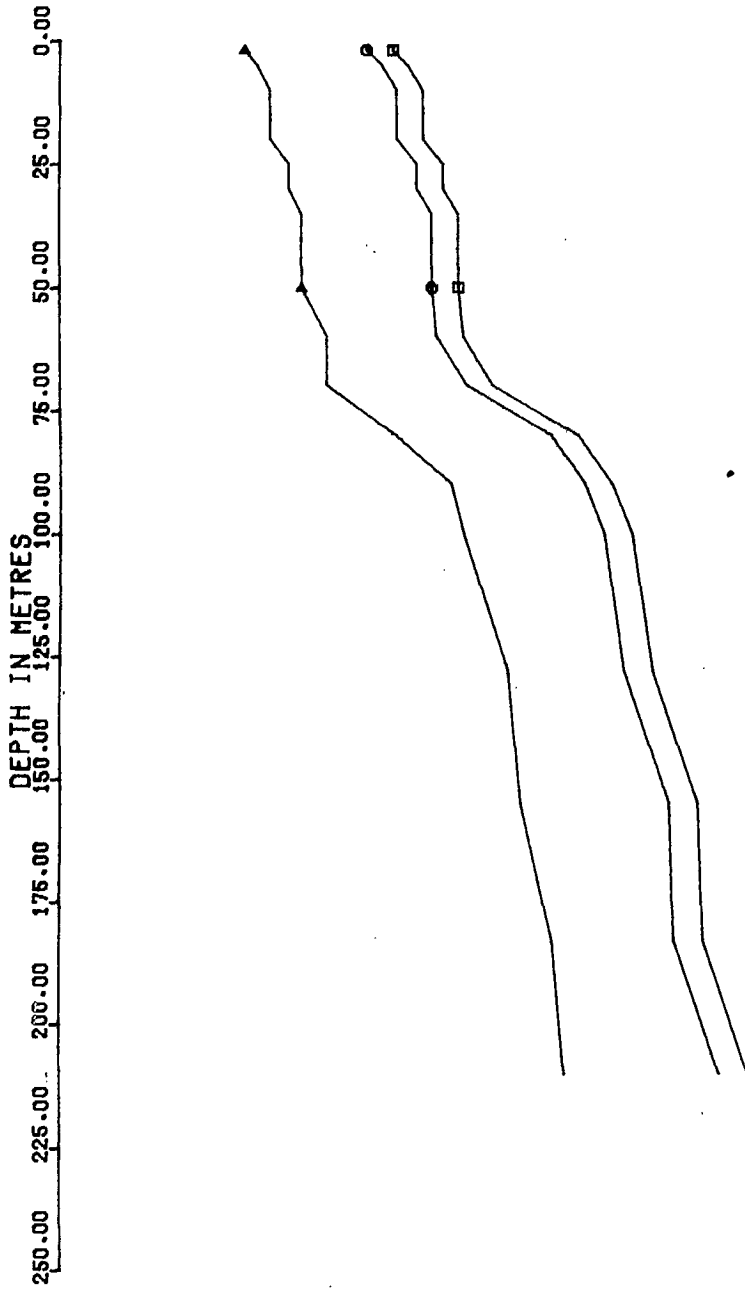
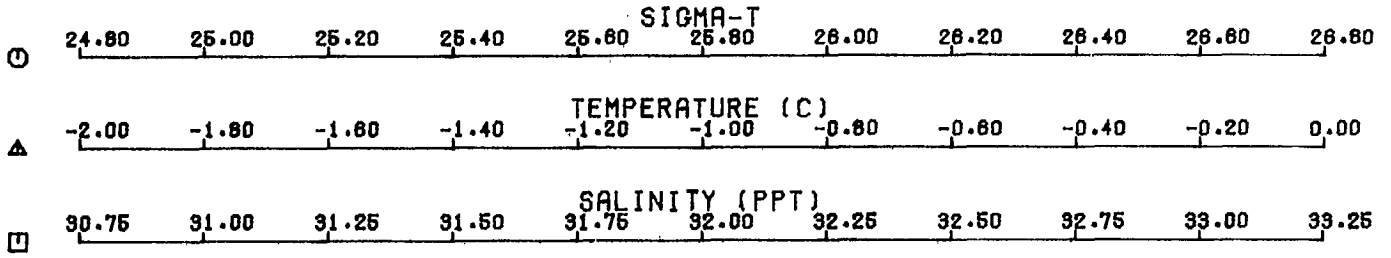

PENNY STRAIT

STATION 15 2 38

2115 GMT 20 4 1976 ICE= 0.6

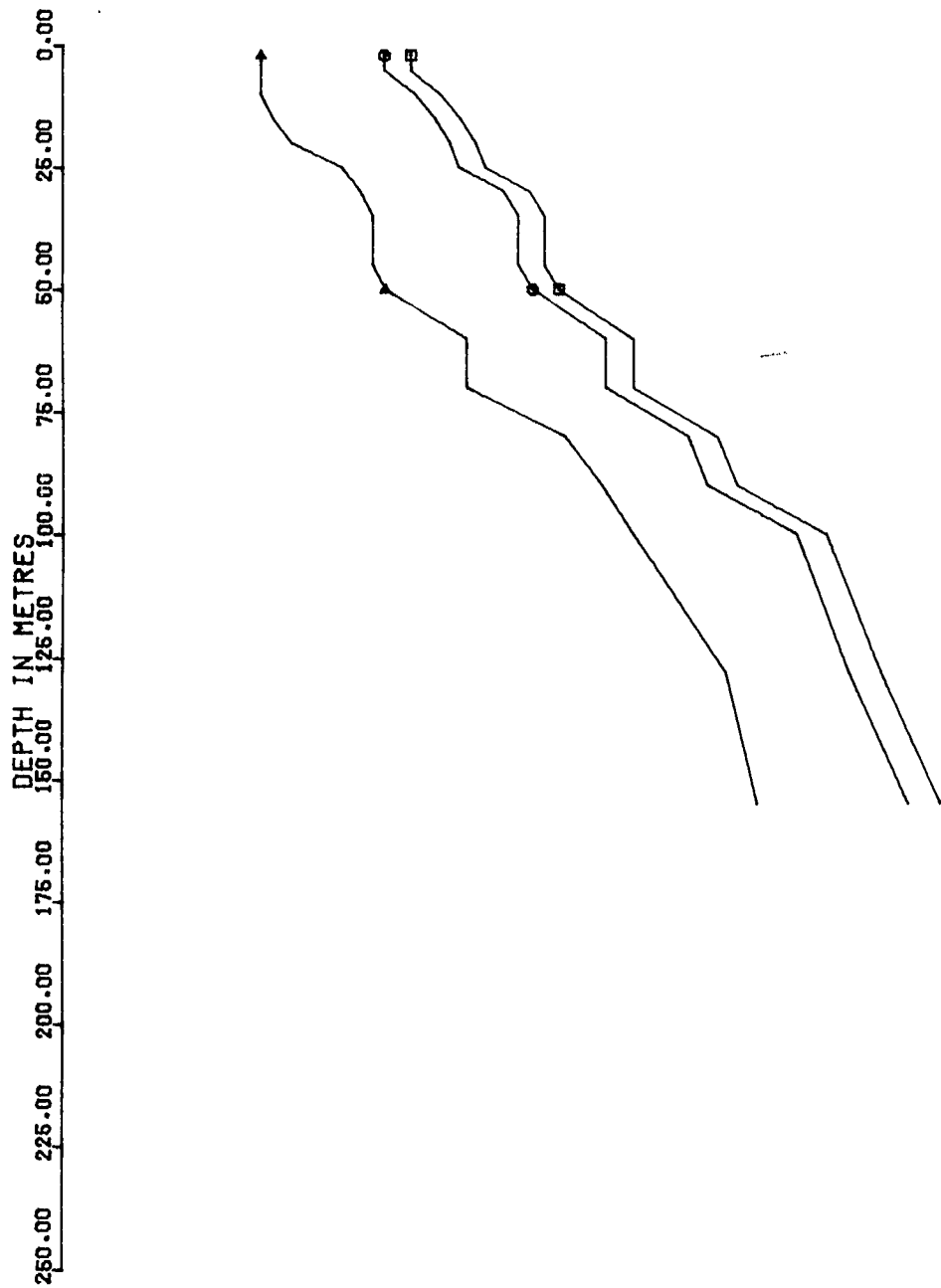
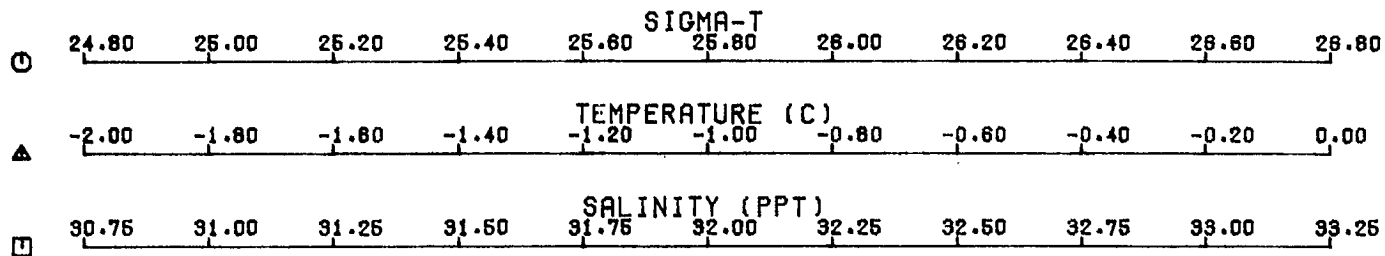

PENNY STRAIT 1976 DATA PROFILES. OKC STATION 14 16 39

LAT 76 38.60 CSTD 803 WATER DEPTH 260.0
 LONG 97 23.80 ICE 2.0 TIME (G.M.T.) 2152
 DATE 20 4 1976

DEPTH	SAL	TEMP	SIGMAT	SOUND
2.0	31.38	-1.72	25.26	1436.2
5.0	31.42	-1.70	25.29	1436.7
10.0	31.43	-1.66	25.30	1436.7
15.0	31.47	-1.59	25.33	1437.2
20.0	31.60	-1.55	25.44	1437.6
25.0	31.66	-1.50	25.48	1438.1
30.0	31.71	-1.44	25.52	1438.5
35.0	31.76	-1.44	25.55	1438.6
40.0	31.80	-1.41	25.58	1438.9
45.0	31.80	-1.41	25.60	1439.0
50.0	31.90	-1.30	25.67	1439.7
60.0	31.94	-1.23	25.71	1440.1
70.0	32.05	-1.17	25.79	1440.9
80.0	32.18	-1.08	25.89	1441.7
90.0	32.30	-1.04	25.99	1442.2
100.0	32.45	-0.97	25.11	1442.6
128.0	32.51	-0.82	26.15	1444.1
137.0	32.59	-0.84	26.22	1444.6
183.0	32.62	-0.82	26.24	1445.2
210.0	32.70	-0.68	26.30	1446.4

PENNY STRAIT 1976 DATA PROFILES. OKC STATION 13 2 40

LAT 76 39.80 CSTD 803 WATER DEPTH 220.0
 LONG 97 16.60 ICE 0.7 TIME (G.M.T.) 2332
 DATE 20 4 1976

DEPTH	SAL	TEMP	SIGMAT	SOUND
2.0	31.48	-1.70	25.34	1436.5
5.0	31.49	-1.66	25.35	1436.7
10.0	31.50	-1.61	25.36	1437.1
15.0	31.55	-1.61	25.40	1437.2
20.0	31.56	-1.57	25.40	1437.5
25.0	31.56	-1.57	25.40	1437.6
30.0	31.63	-1.53	25.46	1437.9
35.0	31.70	-1.48	25.52	1438.4
40.0	31.73	-1.46	25.54	1438.5
45.0	31.76	-1.44	25.56	1438.5
50.0	31.88	-1.32	25.66	1439.5
55.0	31.98	-1.28	25.71	1440.1
70.0	31.94	-1.23	25.71	1440.2
80.0	31.99	-1.24	25.71	1440.6
90.0	31.99	-1.17	25.74	1441.1
128.0	32.22	-1.08	25.08	1442.6
137.0	32.41	-0.86	25.10	1444.3
183.0	32.58	-0.88	25.21	1444.8
210.0	32.82	-0.64	26.40	1445.7

PENNY STRAIT

STATION 14 16 39

2152 GMT 20 4 1976 ICE= 2.0

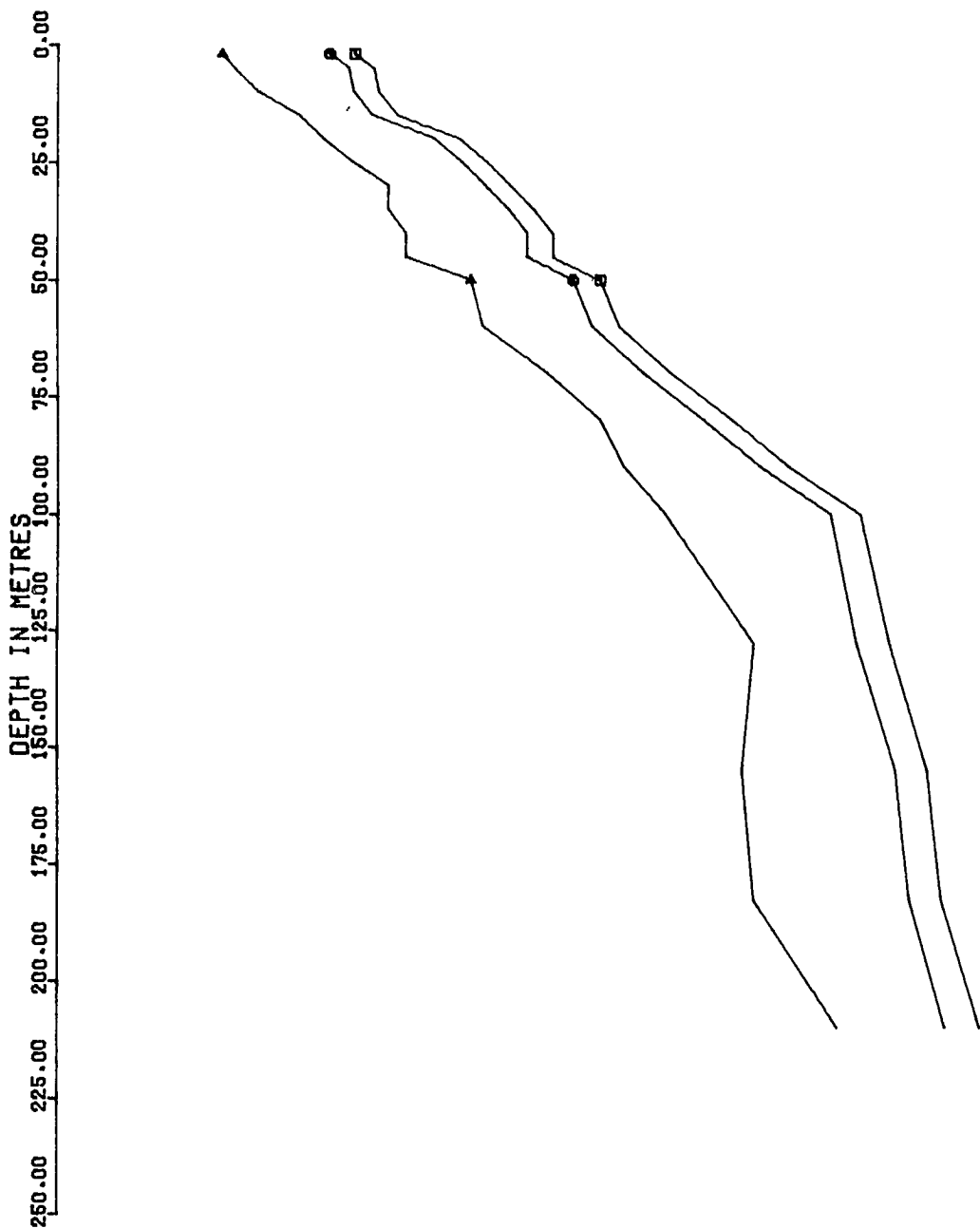
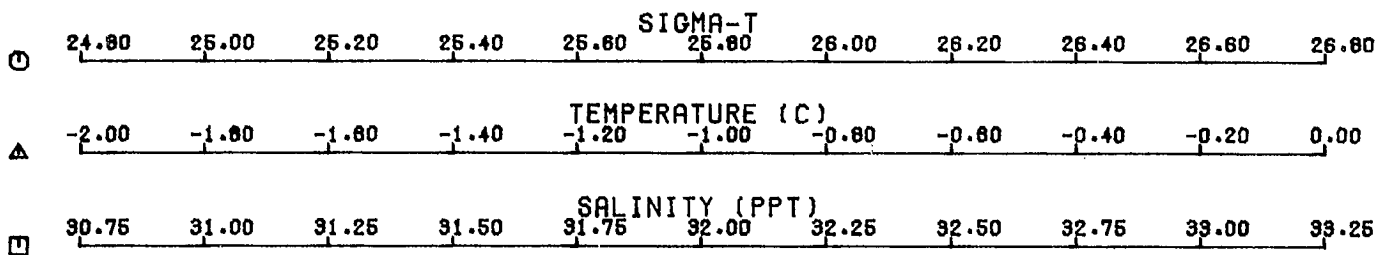

PENNY STRAIT

STATION 13 2 40

2332 GMT 20 4 1976 ICE= 0.7

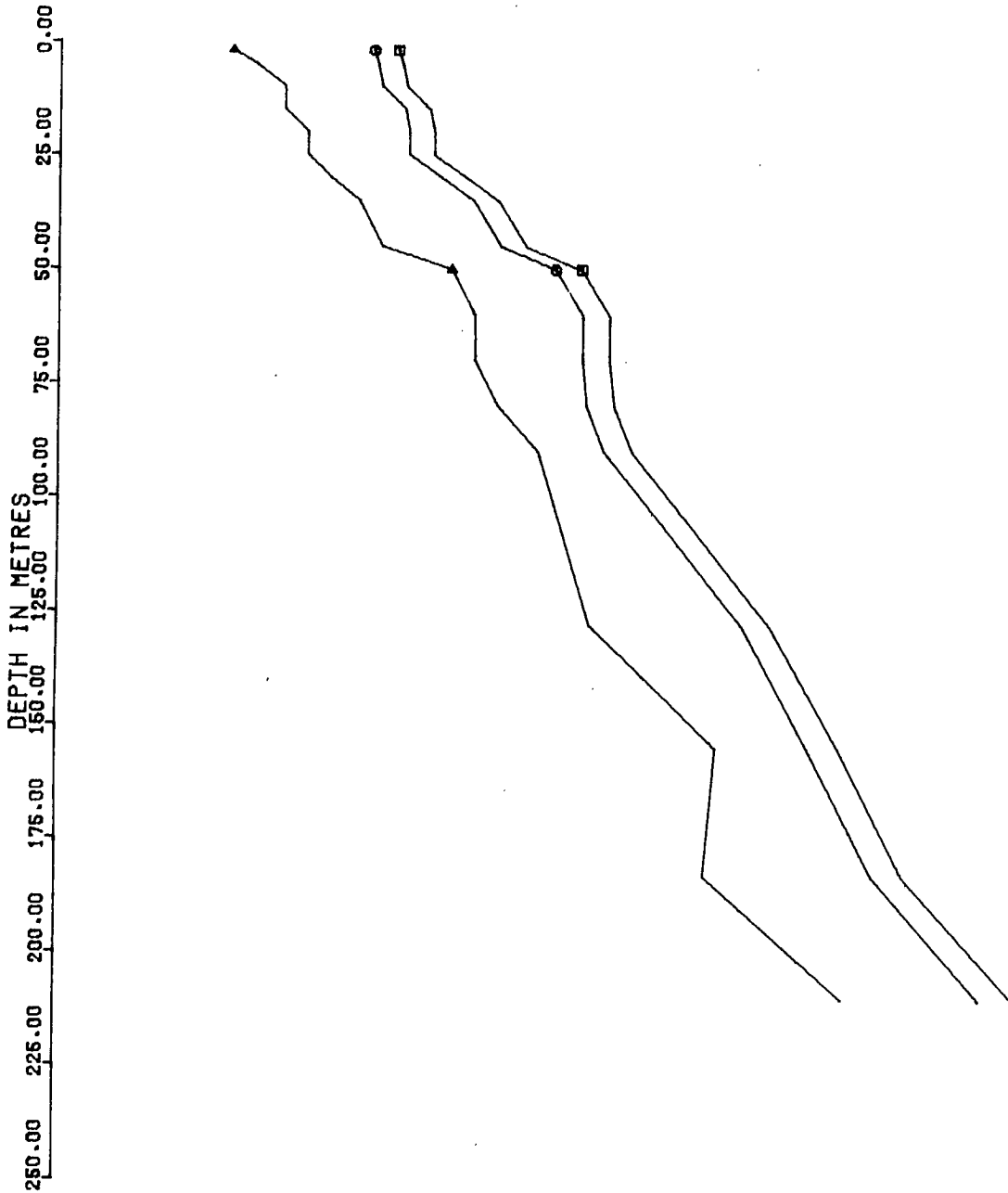
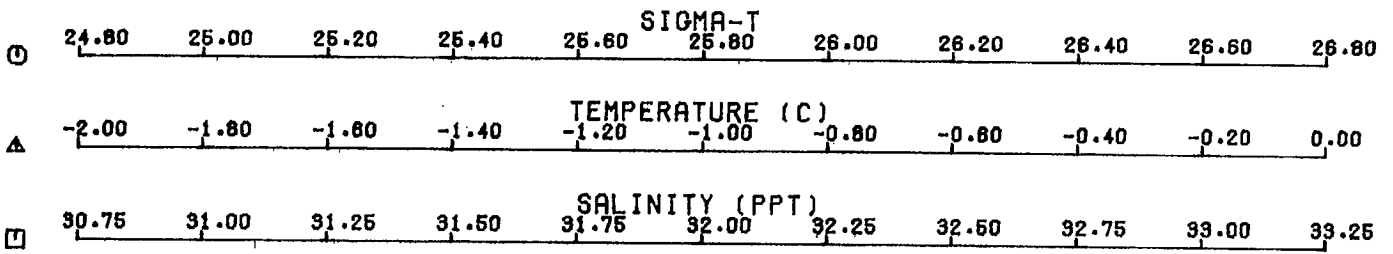

PENNY STRAIT 1976 DATA PROFILES. OKC STATION 12 17 41
 LAT 76 41.50 CSTN 803 WATER DEPTH 187.0
 LONG 97 7.00 ICE 0.8 TIME (G.M.T.) 2312
 DATE 20 4 1976

DEPTH	SAL	TEMP	SIGMAT	SOUND
2.0	31.53	-1.70	25.38	1436.5
5.0	31.55 2	-1.66	25.40	1436.8
10.0	31.58	-1.63	25.42	1437.1
15.0	31.62	-1.57	25.45	1437.5
20.0	31.68	-1.57	25.50	1437.7
25.0	31.69	-1.52	25.51	1438.0
30.0	31.69	-1.52	25.51	1438.1
35.0	31.72	-1.50	25.53	1438.3
40.0	31.83	-1.50	25.62	1438.5
45.0	31.84	-1.46	25.63	1438.8
50.0	31.90	-1.46	25.68	1439.0
55.0	32.01	-1.39	25.75	1439.8
60.0	32.11	-1.28	25.84	1440.5
70.0	32.16 2	-1.21	25.88	1441.0
80.0	32.17 2	-1.17	25.89	1441.4
90.0	32.35	-1.04	25.93	1442.4
100.0	32.52	-0.89	25.16	1443.9
128.0	32.56	-0.85	25.19	1444.5
157.0	32.59	-0.84	26.22	1445.0
183.0				

PENNY STRAIT 1976 DATA PROFILES. OKC STATION 11 3 42
 LAT 76 42.80 CSTN 803 WATER DEPTH 192.0
 LONG 96 56.70 ICE 0.8 TIME (G.M.T.) 2340
 DATE 20 4 1976

DEPTH	SAL	TEMP	SIGMAT	SOUND
2.0	31.77	-1.70 2	25.58	1436.9
5.0	31.80 2	-1.68 2	25.60	1437.1
10.0	31.81 2	-1.64 2	25.61	1437.4
15.0	31.82 2	-1.59	25.62	1437.7
20.0	31.83	-1.55	25.62	1438.0
25.0	31.83	-1.55	25.62	1438.0
30.0	31.89 2	-1.55 2	25.67	1438.2
35.0	31.92	-1.52	25.70	1438.5
40.0	31.92 2	-1.53 2	25.70	1438.5
45.0	31.93	-1.48	25.70	1438.8
50.0	32.01 2	-1.39 2	25.77	1439.5
55.0	32.03	-1.37	25.78	1439.8
60.0	32.10	-1.17	25.83	1441.0
70.0	32.22	-1.13	25.93	1441.5
80.0	32.30 2	-1.08	25.99	1442.0
90.0	32.32	-1.06	26.01	1442.3
100.0	32.44	-0.90	26.10	1443.7
128.0	32.49	-0.90	26.14	1444.2
157.0	32.49	-0.99	26.14	1444.6
183.0				

PENNY STRAIT

STATION 12 17 41

2312 GMT 20 4 1976 ICE= 0.8

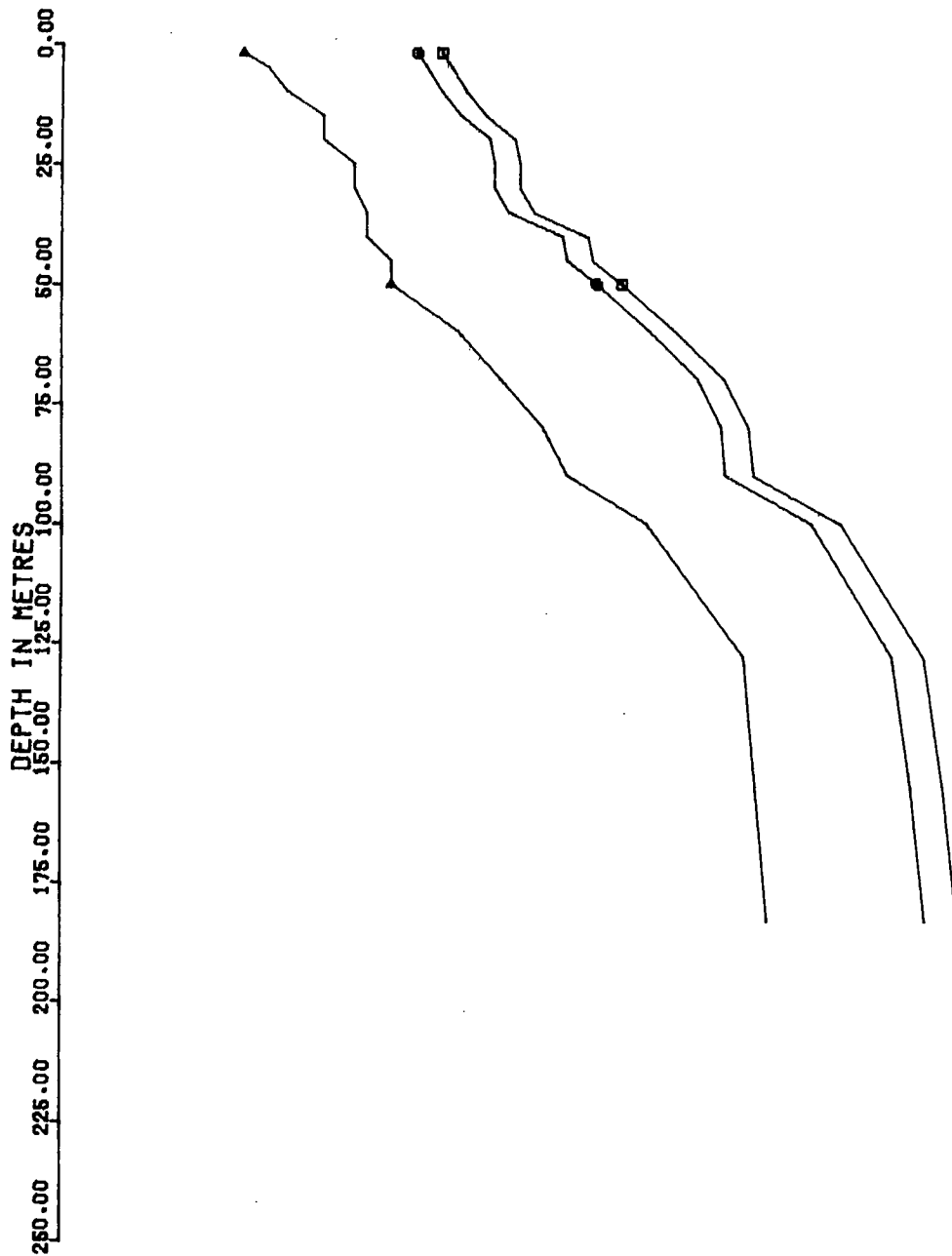
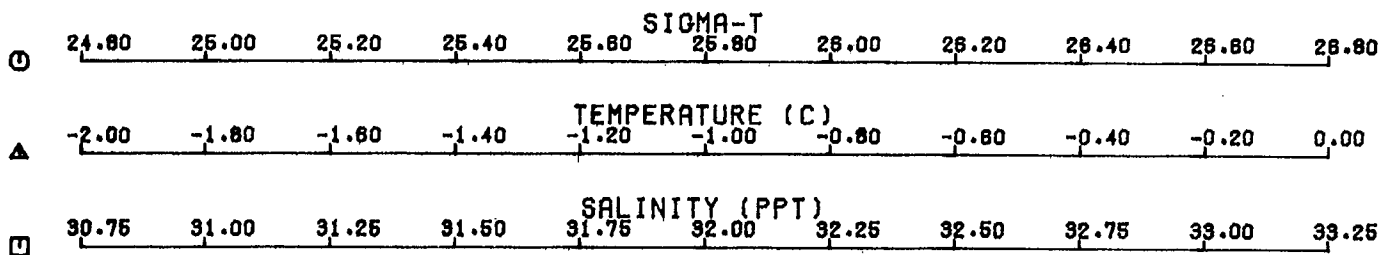

PENNY STRAIT

STATION 11 3 42

2340 GMT 20 4 1976 ICE= 0.8

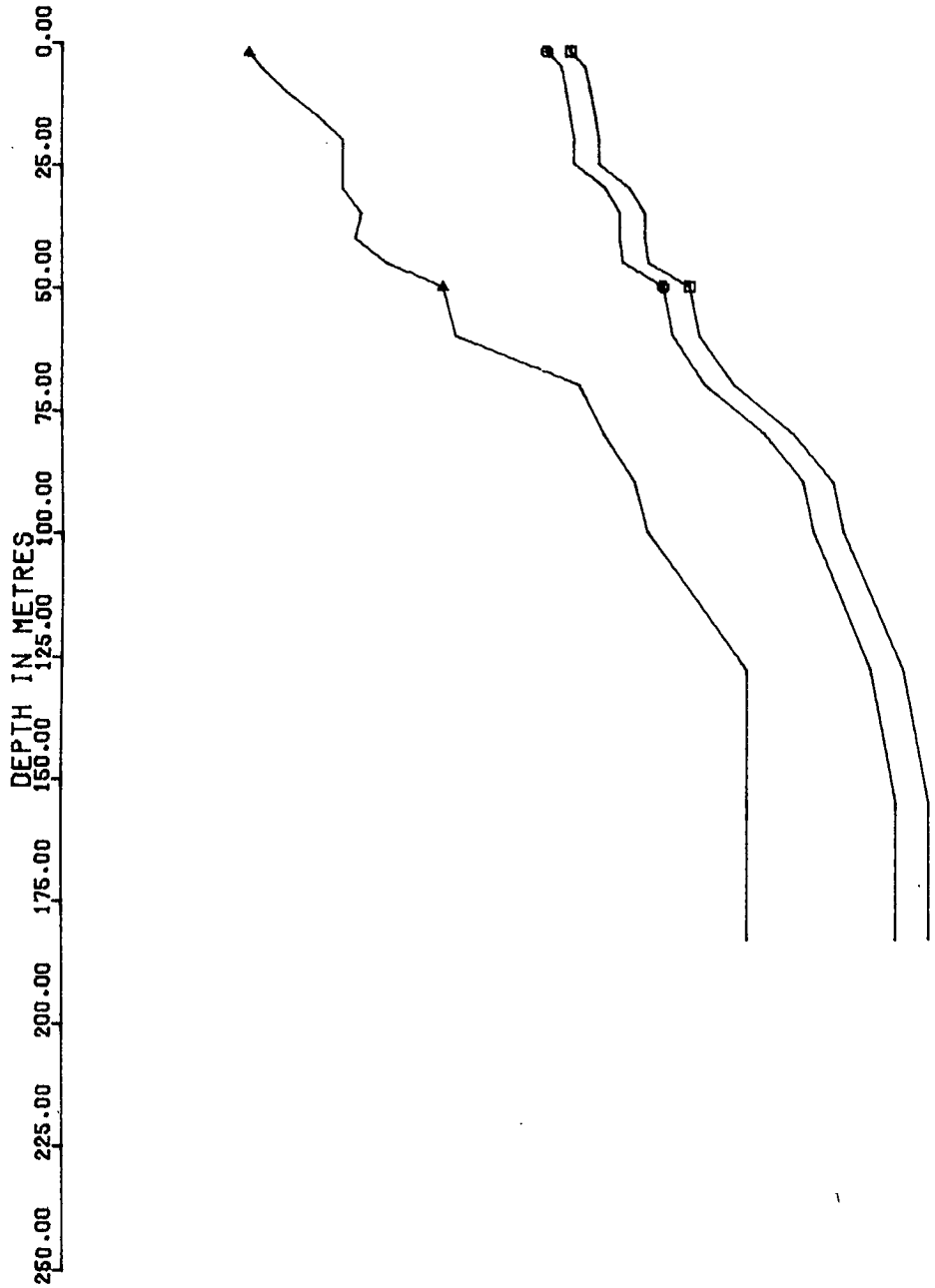
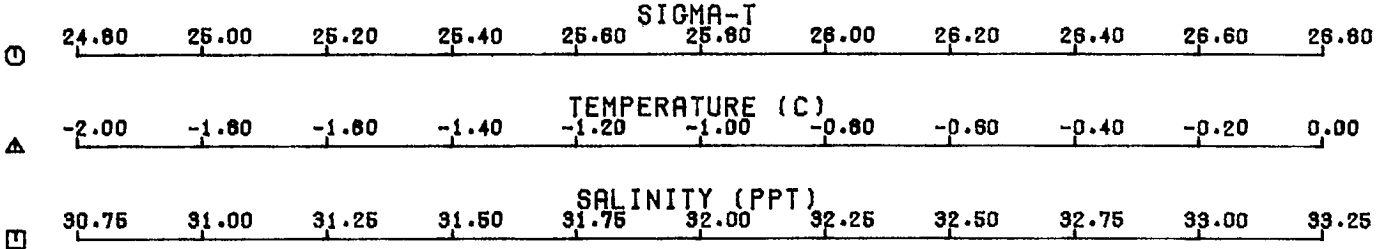

PENNY STRAIT 1976 DATA PROFILES. OKC STATION 15 3 43

LAT 76 31.40 CSTD 803 WATER DEPTH 225.0

LONG 97 42.80 ICE 0.7 TIME (G.M.T.) 0055

DATE 22 4 1976

DEPTH	SAL	TEMP	SIGMAT	SOUND
2.0	31.05	-1.57	24.99	1436.5
10.0	31.35	-1.53	25.24	1436.8
20.0	31.42	-1.53	25.29	1437.2
30.0	31.52	-1.52	25.37	1437.8
40.0	31.56 2	-1.46	25.40	1438.3
50.0	31.57	-1.41	25.41	1438.8
60.0	31.66	-1.39	25.48	1439.1
70.0	31.72	-1.32	25.53	1439.4
80.0	31.75	-1.37	25.55	1439.7
90.0	31.75	-1.37	25.55	1439.9
100.0	31.78	-1.35	25.58	1440.2
125.0	31.82	-1.32	25.61	1440.8
150.0	31.90	-1.30	25.67	1441.4
175.0	31.94	-1.28	25.71	1441.9
200.0	32.06	-1.24	25.80	1442.7

PENNY STRAIT 1976 DATA PROFILES. OKC STATION 15 3 44

LAT 76 36.30 CSTD 803 WATER DEPTH 190.0

LONG 97 28.50 ICE 0.5 TIME (G.M.T.) 0127

DATE 22 4 1976

DEPTH	SAL	TEMP	SIGMAT	SOUND
2.0	31.42	-1.70	25.29	1436.4
10.0	31.42	-1.70	25.29	1436.5
20.0	31.42	-1.70	25.29	1436.7
30.0	31.45	-1.68	25.32	1437.0
40.0	31.54	-1.55	25.36	1437.9
50.0	31.66	-1.50	25.48	1438.5
60.0	31.71	-1.44	25.52	1439.0
70.0	31.83	-1.39	25.62	1439.5
80.0	31.84	-1.35	25.63	1439.9
90.0	31.93	-1.32	25.70	1440.3
100.0	32.00	-1.24	25.75	1441.0
125.0	32.35	-1.04	26.03	1442.8
150.0	32.35	-0.91	26.19	1444.1
175.0	32.66	-0.75	26.27	1445.4
185.0	32.72	-0.75	26.32	1445.7

PENNY STRAIT

STATION 16 3 43

0055 GMT 22 4 1976 ICE= 0.7

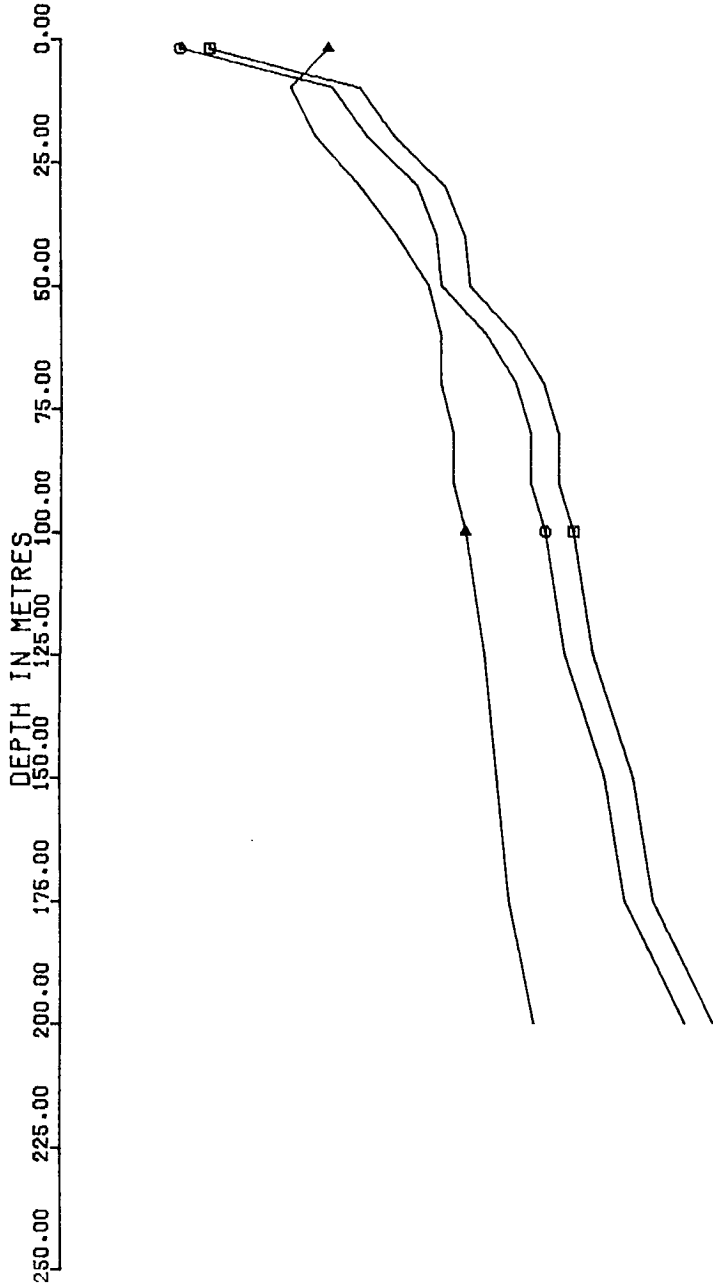
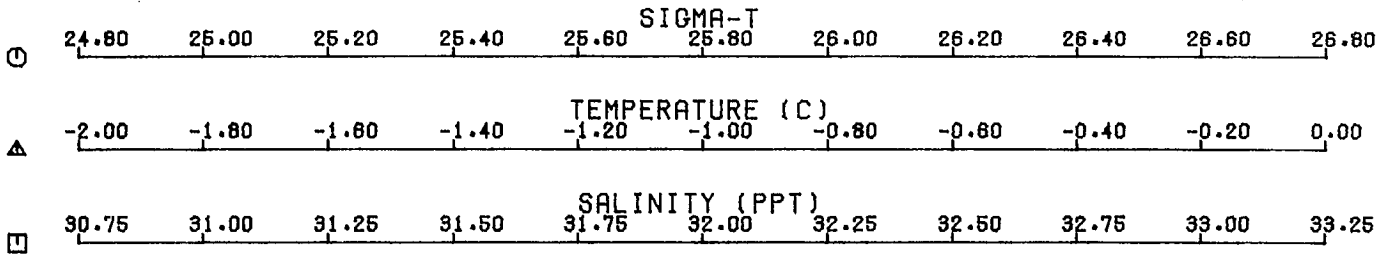

PENNY STRAIT

STATION 15 3 44

0127 GMT 22 4 1976 ICE= 0.5

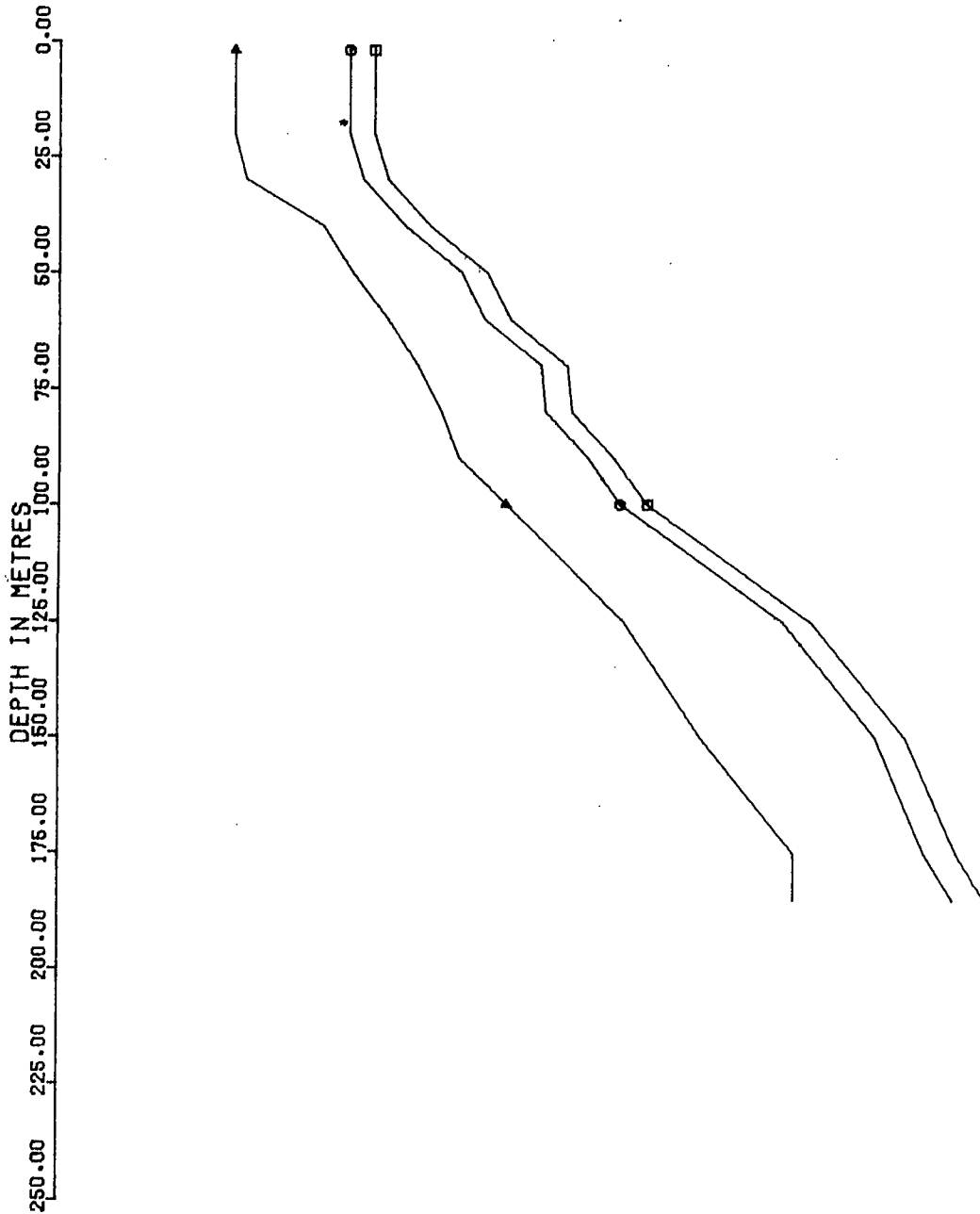
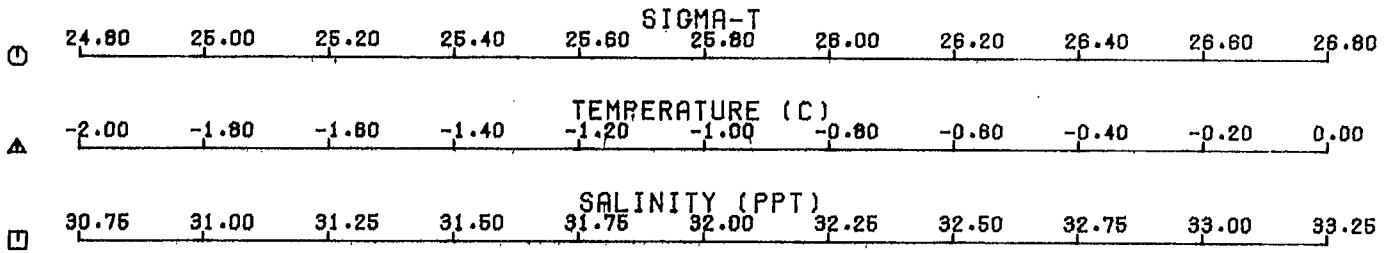

PENNY STRAIT 1976 DATA PROFILES. OKC STATION 14 17 45
 LAT 76 38.60 CSTD 803 WATER DEPTH 269.0
 LONG 97 23.80 ICE 2.0 TIME (G.M.T.) 0155
 DATE 22 4 1976

DEPTH	SAL	TEMP	SIGMAT	SOUND
2.0	31.35 2	-1.75 2	25.24	1436.1
10.0	31.38	-1.72	25.25	1436.4
20.0	31.43	-1.66	25.30	1436.9
30.0	31.53	-1.59	25.38	1437.5
40.0	31.63	-1.52	25.46	1438.2
50.0	31.80	-1.41	25.60	1439.1
60.0	31.87	-1.32	25.65	1439.8
70.0	31.90 2	-1.30	25.67	1440.1
80.0	31.90	-1.30	25.67	1440.2
90.0	31.97	-1.26	25.73	1440.7
100.0	32.04	-1.21	25.79	1441.2
125.0	32.29	-1.08	25.92	1442.6
150.0	32.72	-0.75	26.32	1445.1
175.0	32.76	-0.68	26.35	1445.9
200.0	32.88	-0.64	26.45	1446.7

PENNY STRAIT 1976 DATA PROFILES. OKC STATION 13 3 46
 LAT 76 39.80 CSTD 803 WATER DEPTH 220.0
 LONG 97 16.60 ICE 0.7 TIME (G.M.T.) 0230
 DATE 22 4 1976

DEPTH	SAL	TEMP	SIGMAT	SOUND
2.0	31.43 2	-1.77 2	25.30	1436.1
10.0	31.47 2	-1.75 2	25.34	1436.3
20.0	31.50	-1.72	25.36	1436.7
30.0	31.55	-1.61	25.40	1437.5
40.0	31.72	-1.50	25.53	1438.4
50.0	31.77	-1.39	25.57	1439.1
60.0	31.87	-1.32	25.65	1439.8
70.0	31.97	-1.26	25.73	1440.4
80.0	32.04	-1.21	25.79	1440.9
90.0	32.11	-1.13	25.84	1441.5
100.0	32.17	-1.13	25.89	1441.7
125.0	32.35	-1.04	25.93	1442.8
150.0	32.48	-0.95	26.13	1443.3
175.0	32.58	-0.88	26.21	1444.7
200.0	32.61	-0.68	26.39	1446.4

PENNY STRAIT

STATION 14 17 45

0155 GMT 22 4 1976 ICE= 2.0

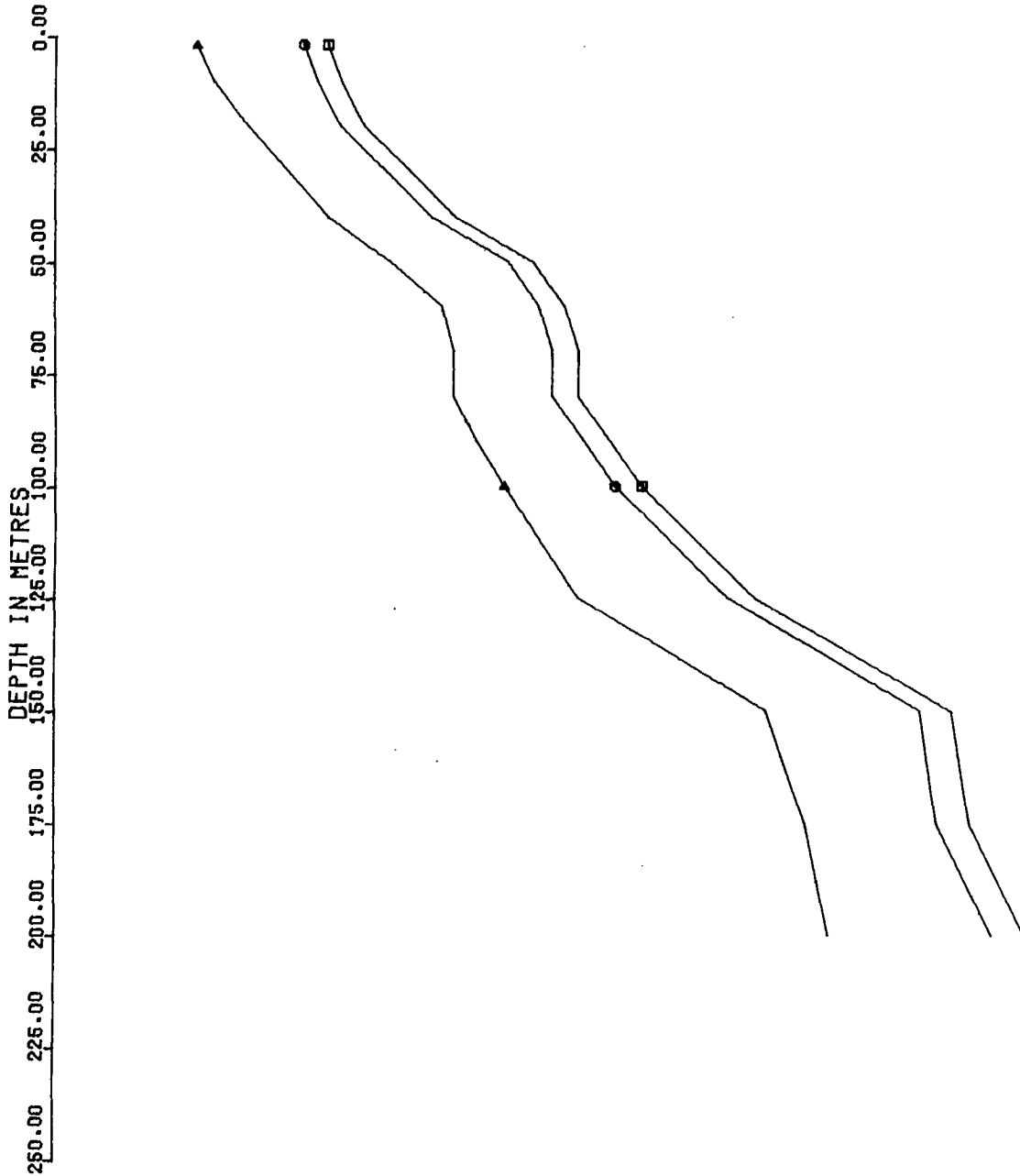
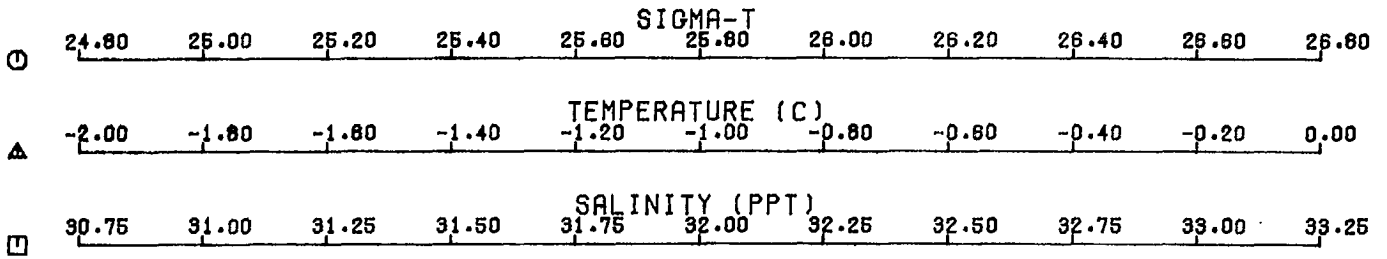

PENNY STRAIT

STATION 13 3 46

0230 GMT 22 4 1976 ICE= 0.7

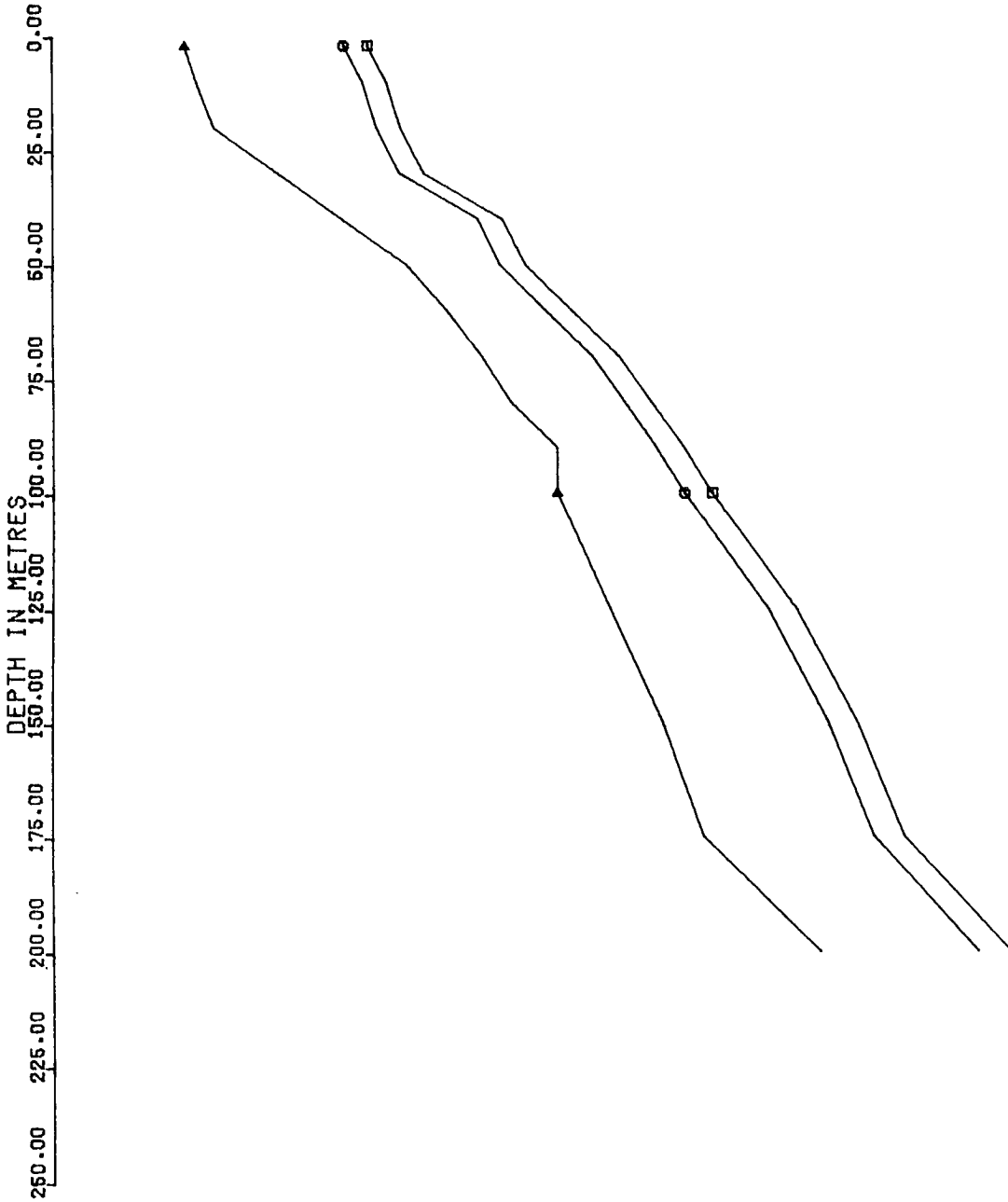
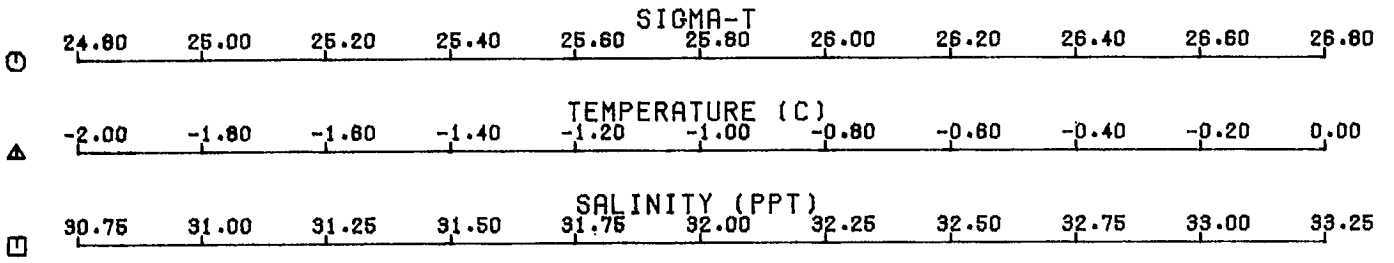

PENNY STRAIT 1976 DATA PROFILES. OKC STATION 12 18 47

LAT 76 41.50 CSTD 303 WATER DEPTH 187.0
 LONG 97 7.00 ICE 0.8 TIME (G.M.T.) 0300
 DATE 22 4 1976

DEPTH	SAL	TEMP	SIGMAT	SOUND
2.0	31.54	-1.70	25.39	1436.6
10.0	31.60	-1.66	25.44	1437.0
20.0	31.61	-1.61 ?	25.45	1437.4
30.0	31.78	-1.50	25.58	1438.3
40.0	31.81	-1.48	25.61	1438.6
50.0	31.87	-1.48	25.65	1438.8
60.0	31.93	-1.44	25.70	1439.3
70.0	32.13	-1.30	25.86	1440.4
80.0	32.14	-1.26	25.87	1440.8
90.0	32.24	-1.19	25.95	1441.4
100.0	32.35	-1.04	25.03	1442.4
125.0	32.52	-0.88	26.16	1443.8
150.0	32.65	-0.79	26.27	1444.6
175.0	32.77	-0.75	26.36	1445.6
185.0	32.82 ?	-0.73	26.40	1445.9

PENNY STRAIT 1976 DATA PROFILES. OKC STATION 11 4 48

LAT 76 42.80 CSTD 803 WATER DEPTH 192.0
 LONG 96 58.70 ICE 0.8 TIME (G.M.T.) 0330
 DATE 22 4 1976

DEPTH	SAL	TEMP	SIGMAT	SOUND
2.0	31.75	-1.74	25.56	1436.7
10.0	31.87 ?	-1.64 ?	25.66	1437.4
20.0	31.90	-1.57	25.58	1438.0
30.0	31.92	-1.52	25.70	1438.4
40.0	32.01	-1.45	25.77	1439.0
50.0	32.13	-1.30	25.86	1440.1
60.0	32.36	-1.15	25.04	1441.3
70.0	32.37	-1.10	25.05	1441.7
80.0	32.48	-1.10	25.14	1442.0
90.0	32.48	-1.10	25.14	1442.2
100.0	32.51 ?	-1.02 ?	25.15	1442.7
125.0	32.52	-0.93	25.15	1443.6
150.0	32.52	-0.88 ?	25.17	1444.2
175.0	32.59	-0.84	25.22	1444.9
190.0	32.59	-0.84	25.22	1445.2

PENNY STRAIT

STATION 12 18 47

0300 GMT 22 4 1976 ICE= 0.8

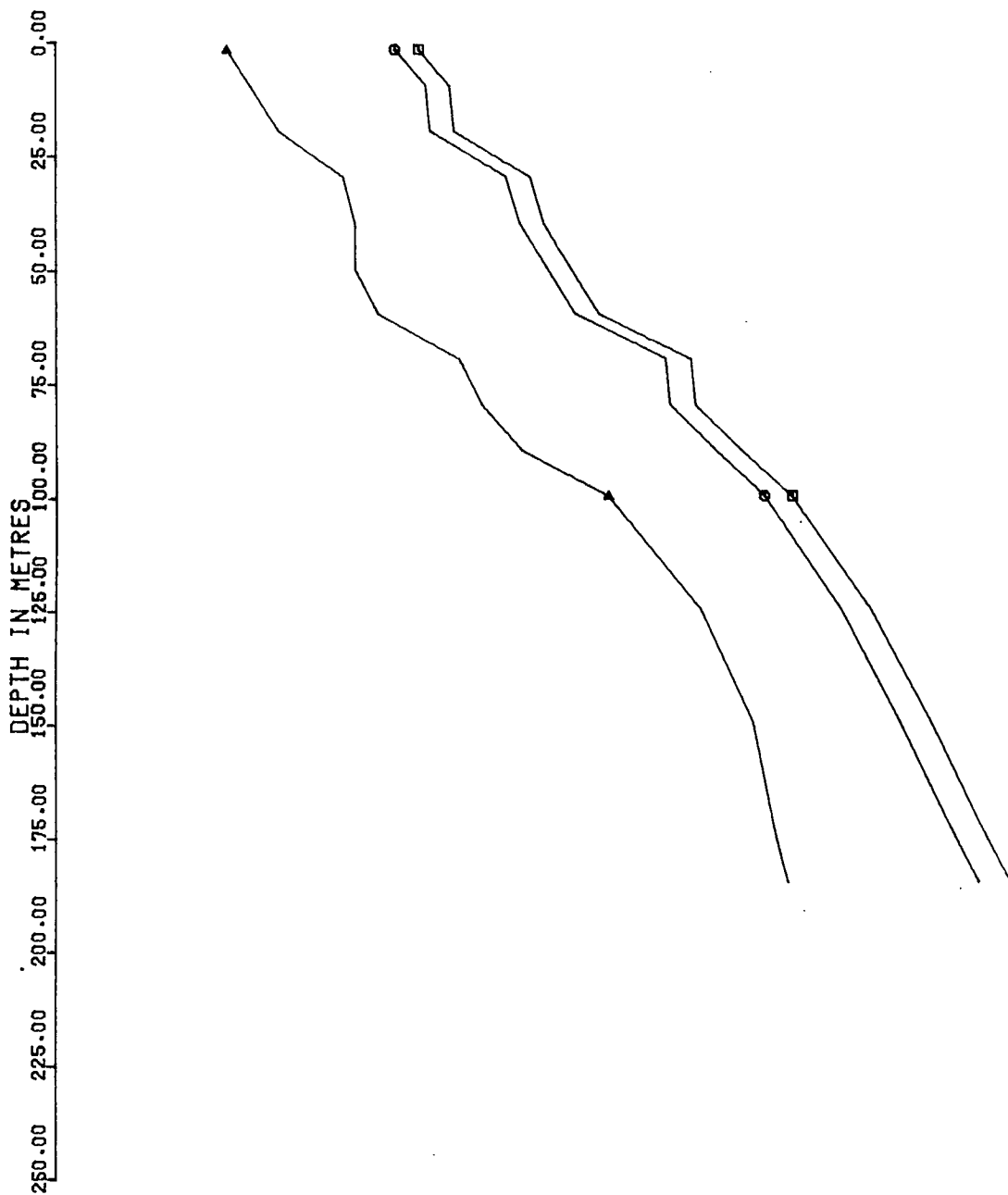
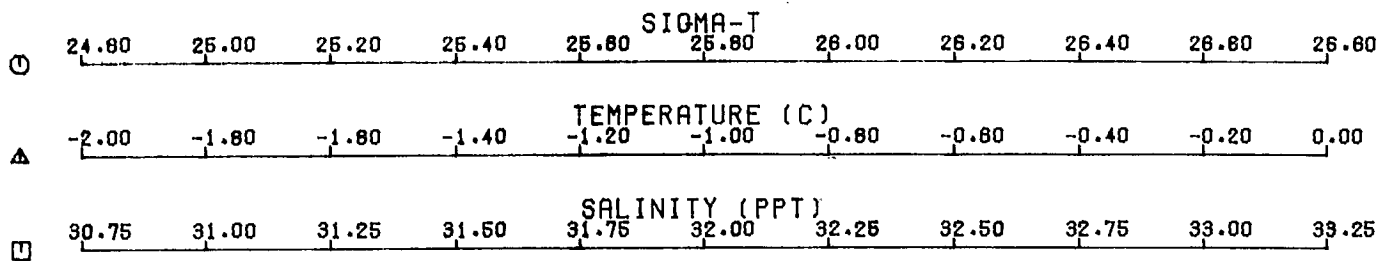

PENNY STRAIT

STATION 11 4 48

0330 GMT 22 4 1976 ICE= 0.8

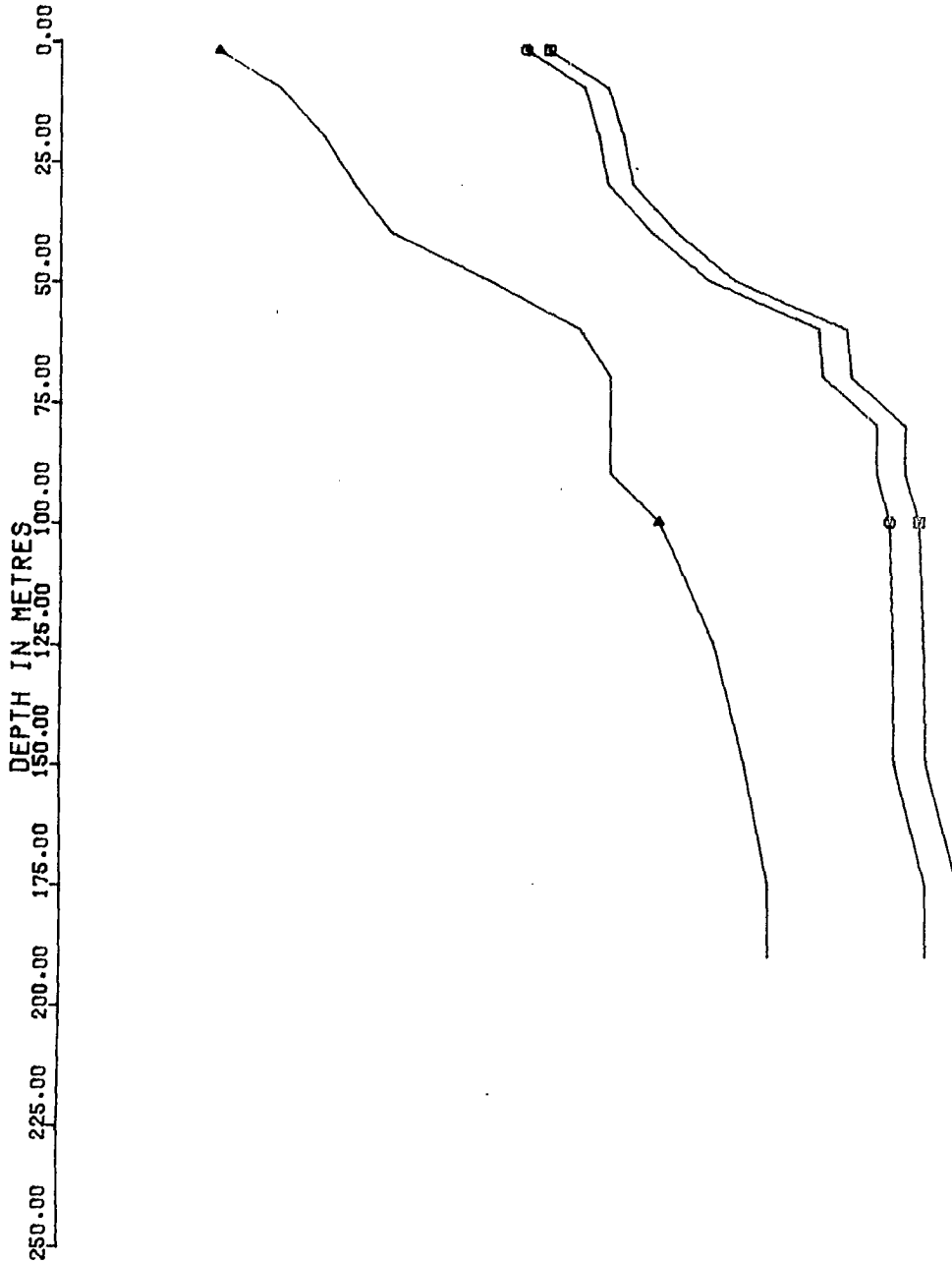
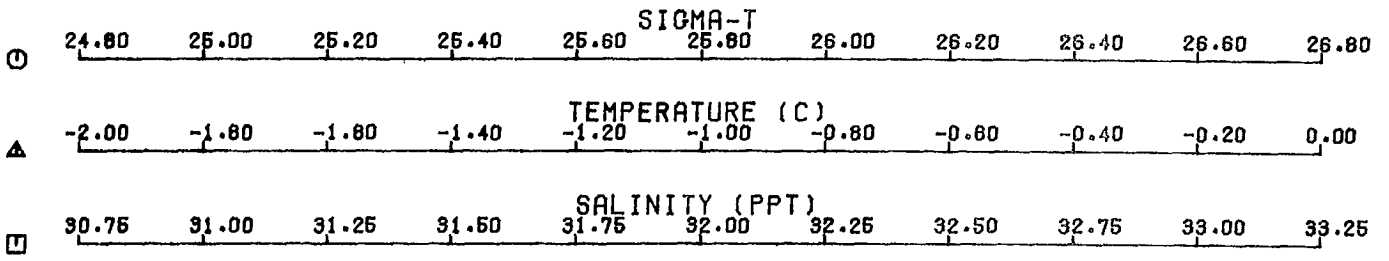

PENNY STRAIT 1976 DATA PROFILES. OKC STATION 15 4 49

LAT 76 31.40 CSTD 803 WATER DEPTH 225.0

LONG 97 42.80 ICE 0.7 TIME (G.M.T.) 1513

DATE 22 4 1976

DEPTH	SAL	TEMP	SIGMAT	SOUND
2.0	31.29	-1.63	25.19	1436.5
10.0	31.29	-1.63	25.19	1436.7
20.0	31.35	-1.63	25.24	1436.7
30.0	31.40	-1.63	25.28	1437.1
40.0	31.44	-1.61	25.31	1437.5
50.0	31.52	-1.52	25.37	1438.2
60.0	31.61	-1.50	25.44	1438.6
70.0	31.65	-1.44	25.48	1439.1
80.0	31.71	-1.44	25.52	1439.3
90.0	31.78	-1.35	25.58	1440.0
100.0	31.84	-1.35	25.63	1440.2
125.0	31.90	-1.30	25.67	1441.0
150.0	31.96	-1.30	25.72	1441.5
175.0	31.99	-1.22	25.74	1442.3
200.0	32.07	-1.19	25.81	1443.0

PENNY STRAIT 1976 DATA PROFILES. OKC STATION 15 4 50

LAT 76 36.30 CSTD 803 WATER DEPTH 190.0

LONG 97 28.60 ICE 0.5 TIME (G.M.T.) 1545

DATE 22 4 1976

DEPTH	SAL	TEMP	SIGMAT	SOUND
2.0	31.30	-1.70	25.20	1436.2
10.0	31.60	-1.55	25.44	1437.5
20.0	31.77	-1.39	25.57	1438.6
30.0	31.85	-1.30	25.63	1439.3
40.0	31.86	-1.26	25.64	1439.7
50.0	31.89	-1.24	25.66	1440.0
60.0	31.95	-1.24	25.71	1440.3
70.0	31.99	-1.21	25.74	1440.6
80.0	32.04	-1.21	25.79	1440.9
90.0	32.05	-1.17	25.79	1441.2
100.0	32.07	-1.08	25.81	1441.8
125.0	32.10	-1.06	25.83	1442.4
150.0	32.15	-1.06	25.87	1442.9
175.0	32.76	-0.68	26.35	1445.0
185.0	32.79	-0.65	26.37	1446.2

PENNY STRAIT

STATION 16 4 49

1513 GMT 22 4 1976 ICE= 0.7

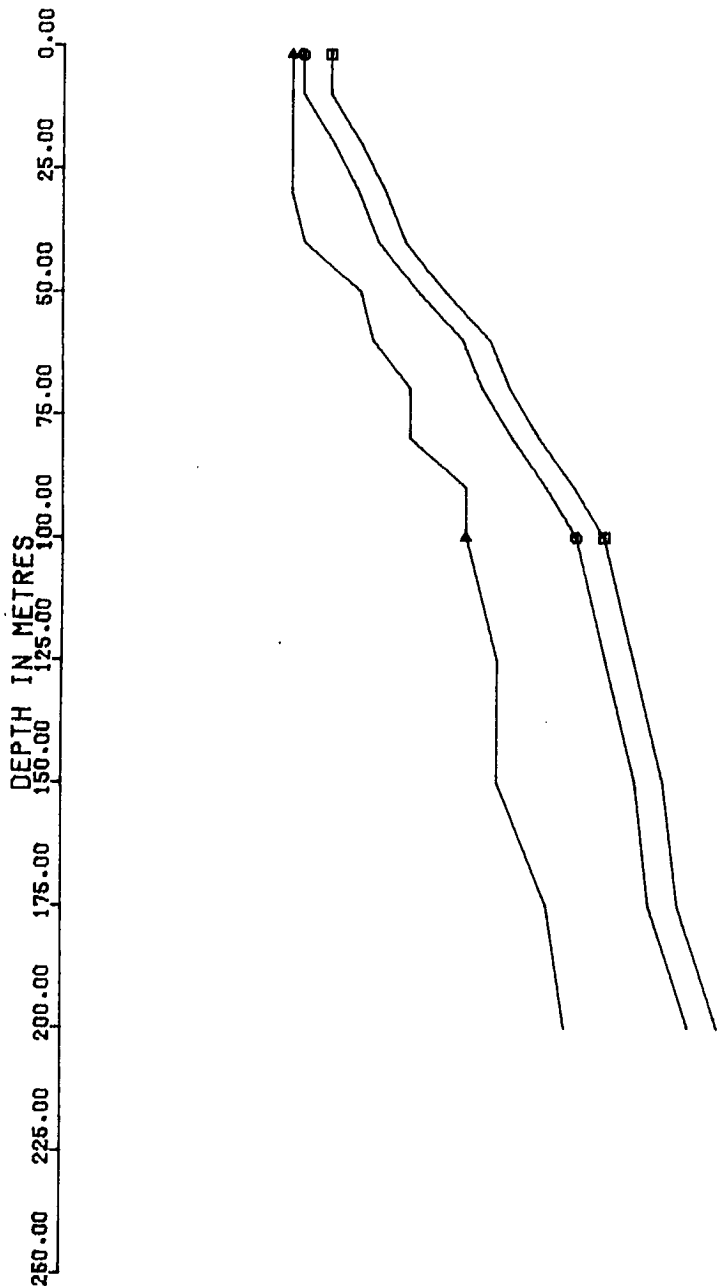
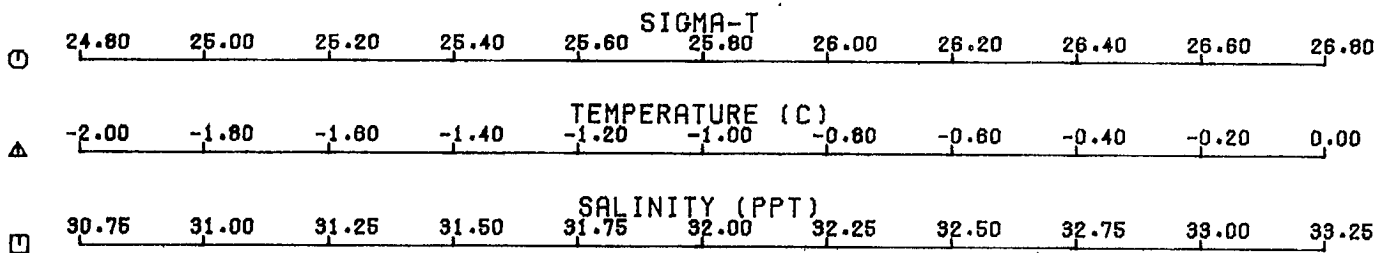

PENNY STRAIT

STATION 15 4 50

1545 GMT 22 4 1976 ICE= 0.5

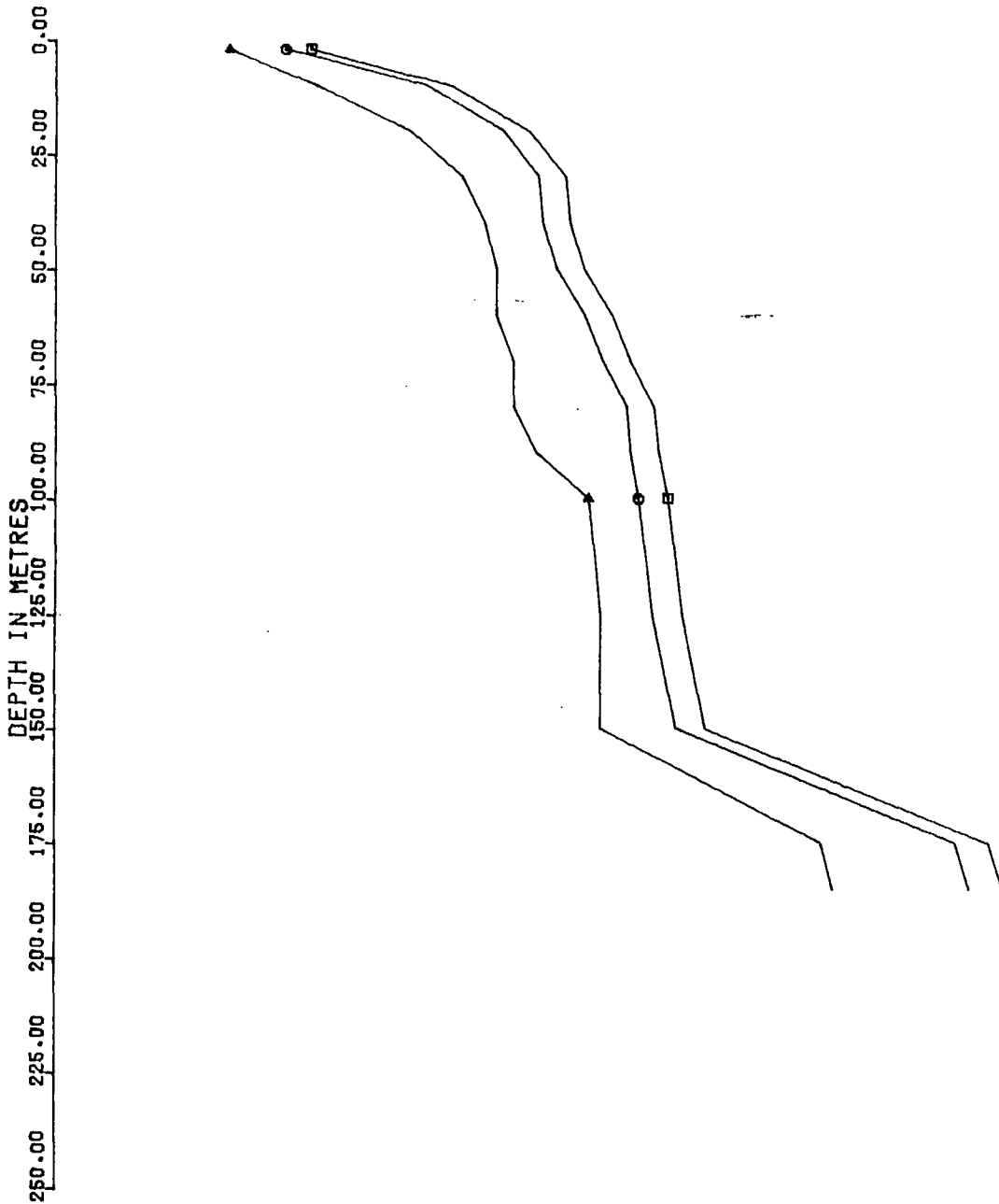
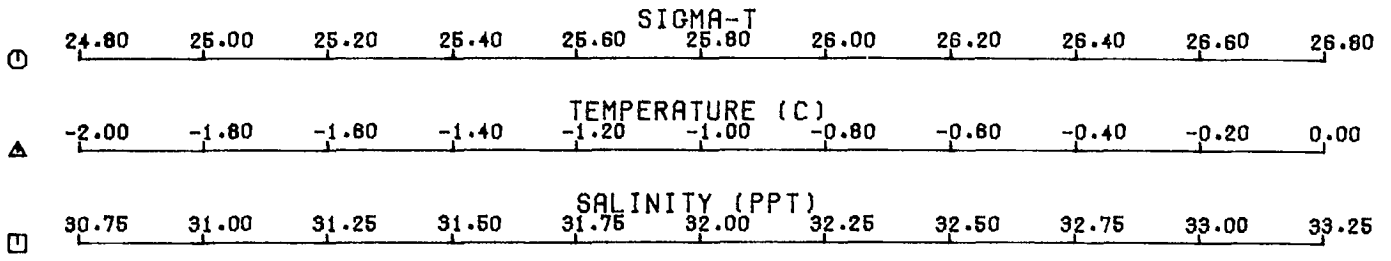

PENNY STRAIT 1976 DATA PROFILES. OKC STATION 14 16 51

LAT 76 38.60 CSTD 803 WATER DEPTH 260.0

LONG 97 23.80 ICF 2.0 TIME (G.M.T.) 1616

DATE 22 4 1976

DEPTH	SAL	TEMP	SIGMAT	SOUND
2.0	31.30 2	-1.72 2	25.27	1436.2
10.0	31.43 2	-1.65 2	25.30	1436.7
20.0	31.45	-1.57	25.32	1437.3
30.0	31.55	-1.50	25.40	1438.0
40.0	31.68	-1.30	25.50	1439.3
50.0	31.79	-1.30	25.59	1439.6
60.0	31.91	-1.25	25.66	1440.1
70.0	32.07	-1.13	25.81	1440.8
80.0	32.06	-1.15	25.82	1441.2
90.0	32.08	-1.15	25.82	1441.4
100.0	32.08 2	-1.15 2	25.82	1441.5
125.0	32.17	-1.13	25.80	1442.1
150.0	32.40	-0.93	25.07	1443.8
175.0	32.86 2	-0.82	25.44	1445.4
200.0	32.94 2	-0.68	26.50	1446.6

PENNY STRAIT 1976 DATA PROFILES. OKC STATION 13 4 52

LAT 76 39.80 CSTD 803 WATER DEPTH 220.0

LONG 97 16.50 ICF 0.7 TIME (G.M.T.) 1645

DATE 22 4 1976

DEPTH	SAL	TEMP	SIGMAT	SOUND
2.0	31.26 2	-1.66 2	25.15	1436.4
10.0	31.27 2	-1.61 2	25.17	1436.7
20.0	31.30	-1.48	25.19	1437.6
30.0	31.70	-1.43	25.52	1438.3
40.0	31.75	-1.37	25.55	1439.0
50.0	31.81	-1.37	25.60	1439.3
60.0	31.90	-1.30	25.67	1439.9
70.0	31.96	-1.30	25.72	1440.2
80.0	32.01	-1.19	25.76	1440.9
90.0	32.33	-1.04	26.03	1442.3
100.0	32.37	-0.95	26.04	1442.9
125.0	32.52	-0.93	26.16	1443.5
150.0	32.53	-0.84	26.17	1444.4
175.0	32.66	-0.75	26.27	1445.4
200.0	32.82	-0.6-	26.40	1446.6

PENNY STRAIT

STATION 14 18 51

1616 GMT 22 4 1976 ICE= 2.0

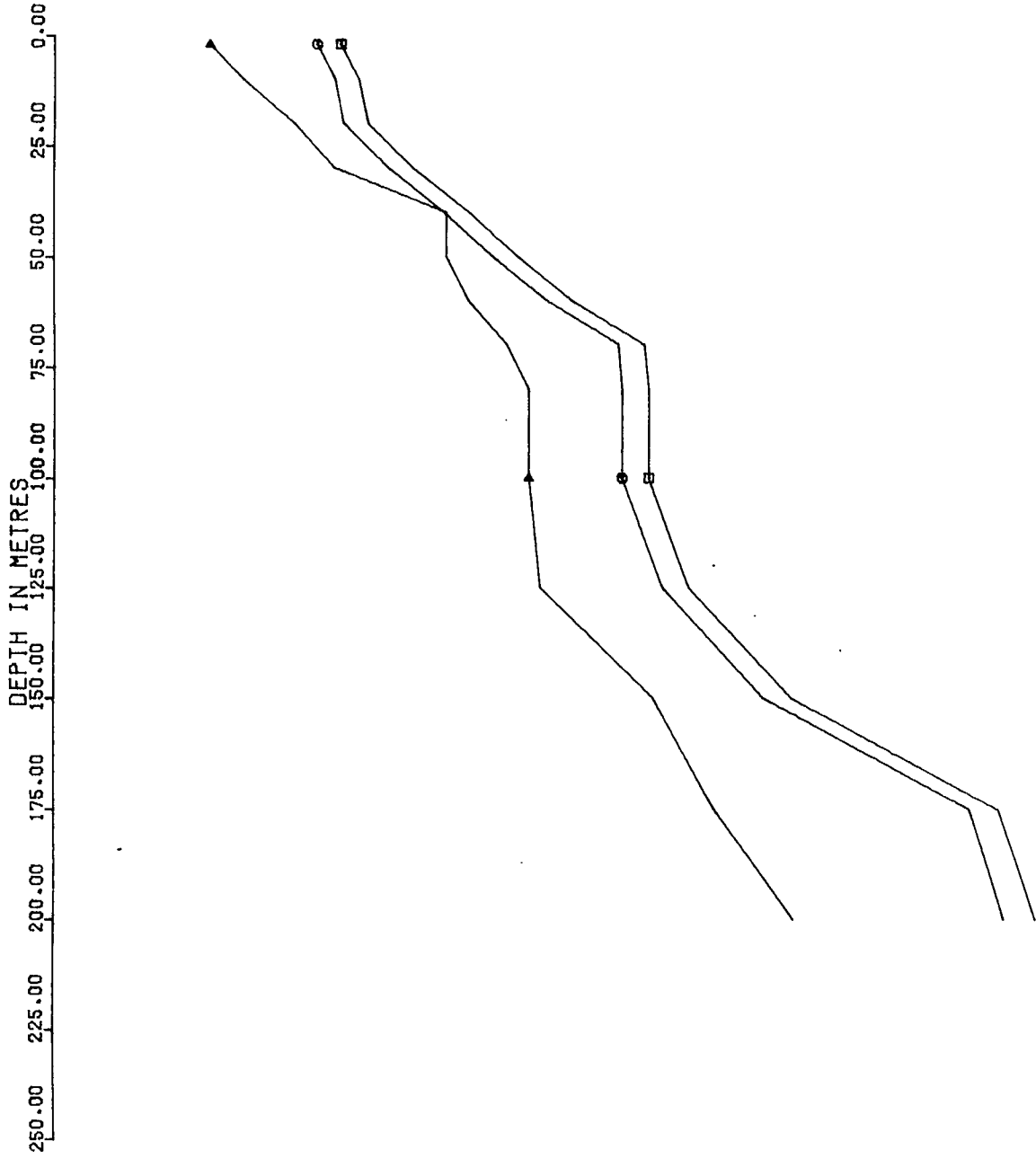
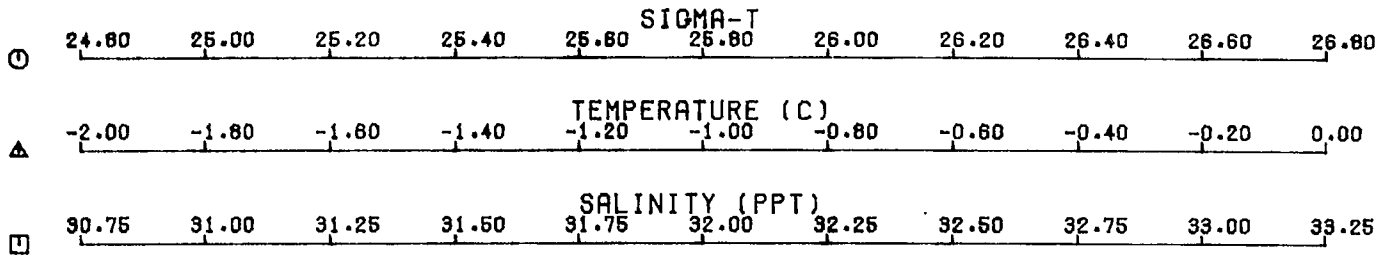

PENNY STRAIT

STATION 13 4 52

1645 GMT 22 4 1976 ICE= 0.7

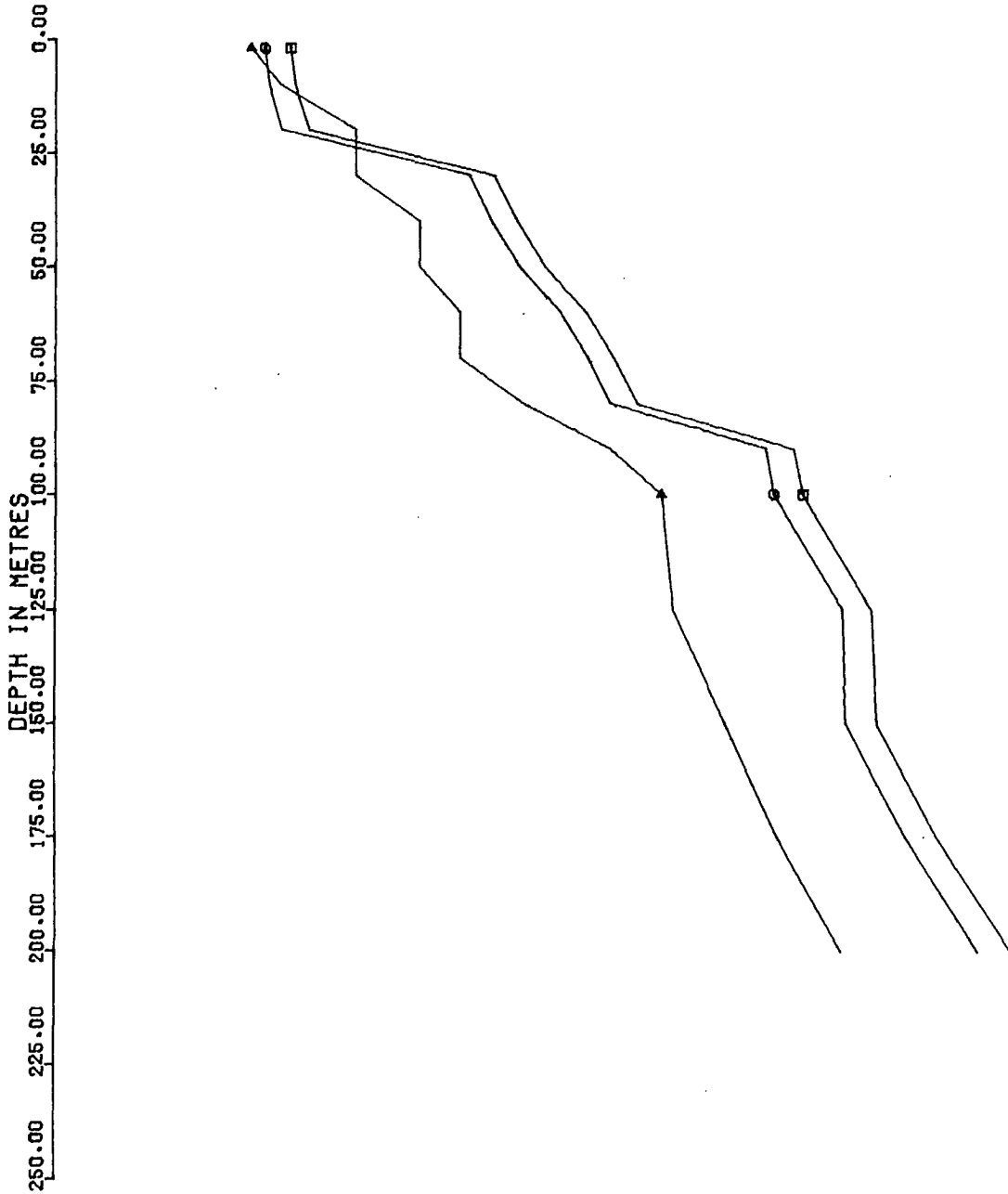
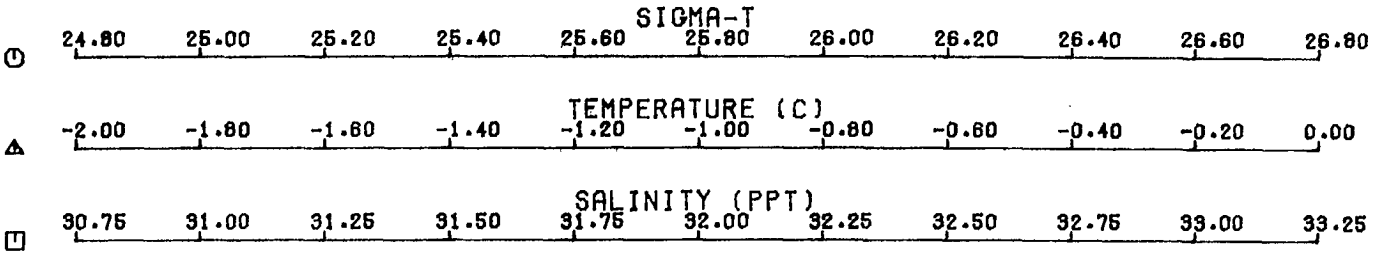

PENNY STRAIT 1976 DATA PROFILES OKC STATION 17 1 53

LAT 76 40.2 CSTD 803 WATER DEPTH 300.0
 LONG 07 12.0 ICE 0.7 TIME (G.M.T.) 1704
 DATE 22 4 1976

DEPTH	SAL	TEMP	SIGMAT	SOUND
25.0	31.62	-1.68	25.46	1437.1
50.0	31.71	-1.55	25.53	1438.3
75.0	32.04	-1.21	25.70	1440.8
100.0	32.32	-1.02	26.06	1442.6
125.0	32.47	-0.88	26.12	1443.7
150.0	32.62	-0.82	26.24	1444.6
175.0	32.66	-0.75	26.27	1445.4
200.0	32.68	-0.70	26.29	1446.1
225.0	32.71	-0.68	26.31	1446.6
250.0	32.71	-0.68	26.31	1447.1
275.0	32.76	-0.63	26.35	1447.6

PENNY STRAIT 1976 DATA PROFILES. OKC STATION 12 19 54

LAT 76 41.50 CSTD 803 WATER DEPTH 187.0
 LONG 07 7.00 ICE 0.8 TIME (G.M.T.) 1745
 DATE 22 4 1976

DEPTH	SAL	TEMP	SIGMAT	SOUND
2.0	31.34 2	-1.79 2	25.23	1435.8
10.0	31.38 2	-1.77 2	25.26	1436.1
20.0	31.41	-1.74	25.28	1436.5
30.0	31.44	-1.72	25.31	1436.9
40.0	31.34	-1.46	25.63	1438.7
50.0	31.92 2	-1.42 2	25.69	1439.2
60.0	32.02	-1.30	25.77	1440.1
70.0	32.26	-1.24	25.89	1440.9
80.0	32.35	-1.08	26.03	1441.3
90.0	32.38	-1.06	26.05	1442.2
100.0	32.39	-1.02	26.06	1442.6
125.0	32.52	-1.03 2	26.17	1443.1
150.0	32.56	-0.97	26.20	1443.9
175.0	32.63	-0.93	26.25	1444.6
185.0	32.67 2	-0.90 2	26.29	1444.9

PENNY STRAIT

STATION 17 1 53

1704 GMT 22 4 1976 ICE= 0.7

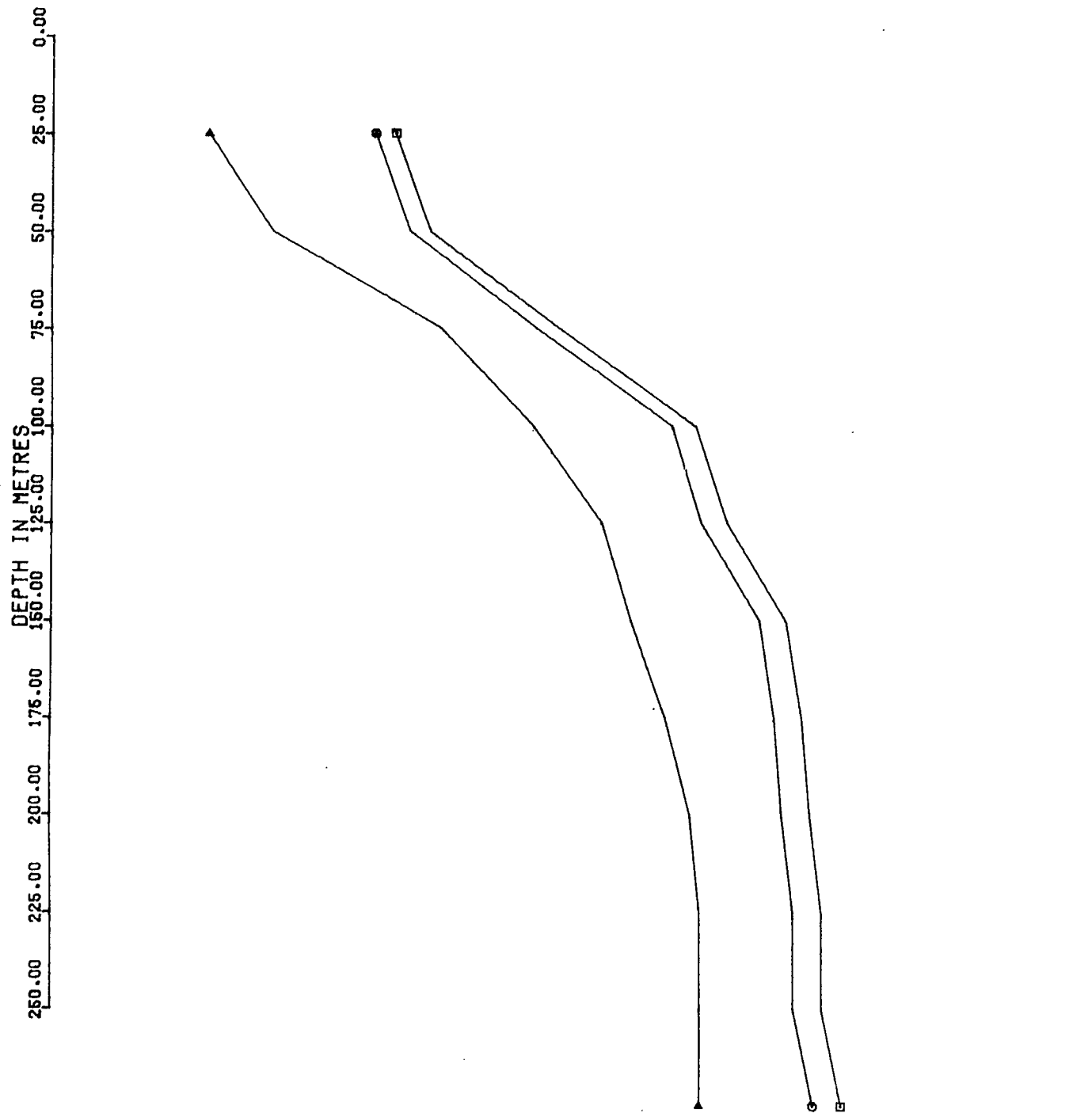
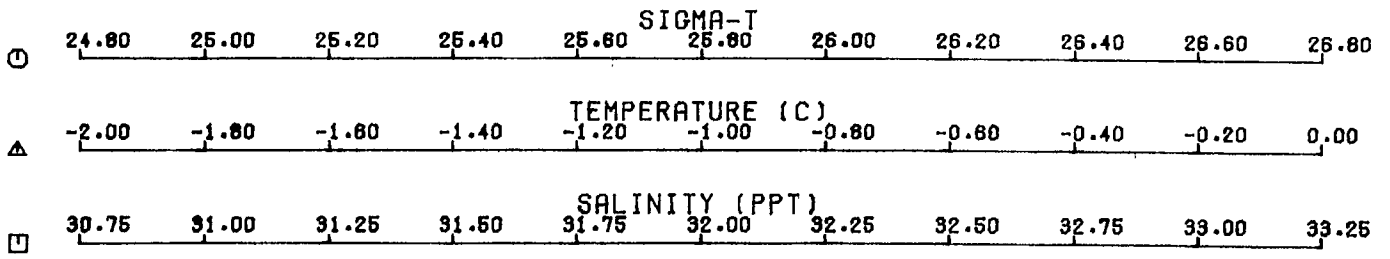

PENNY STRAIT

STATION 12 19 54

1745 GMT 22 4 1976 ICE= 0.8

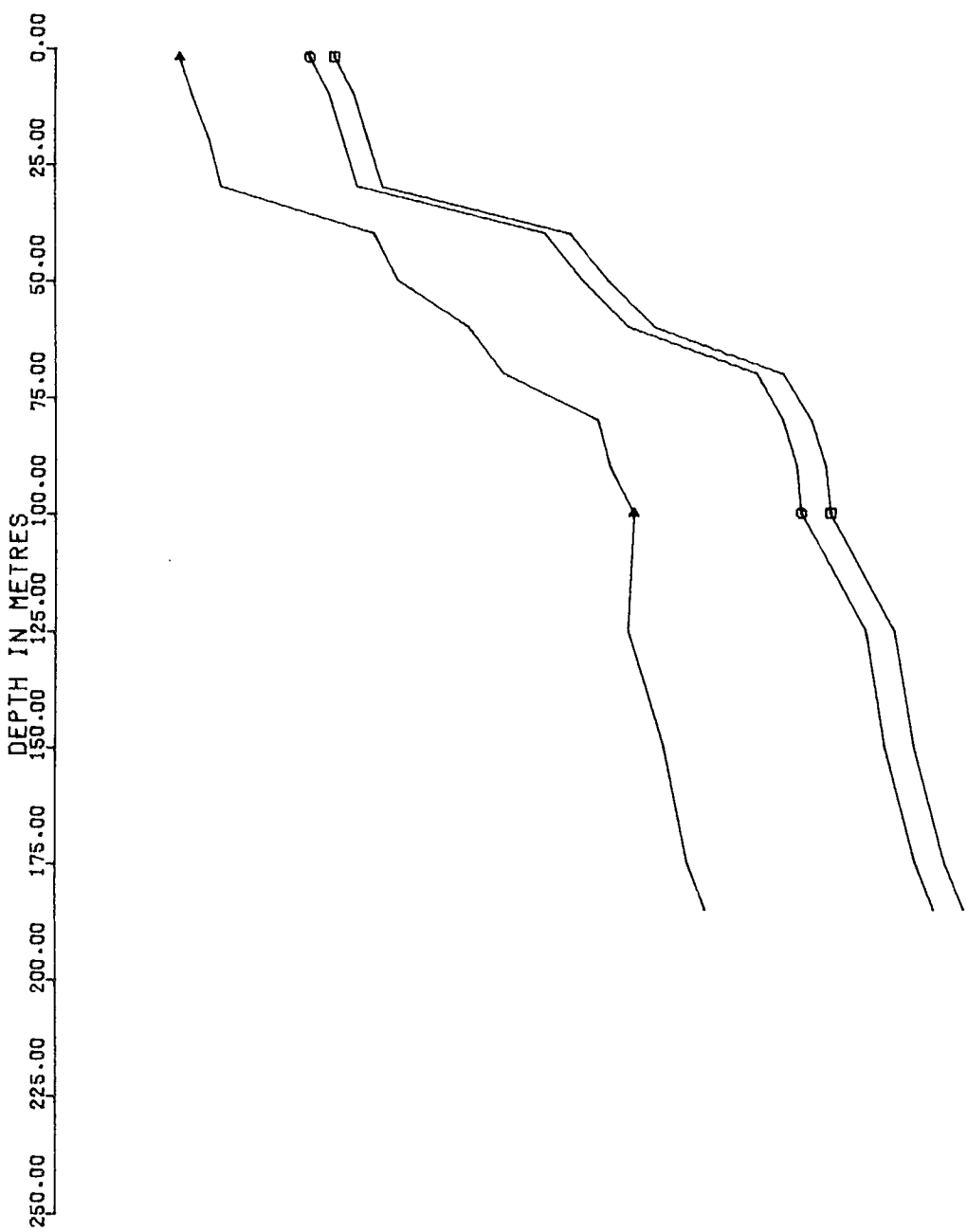
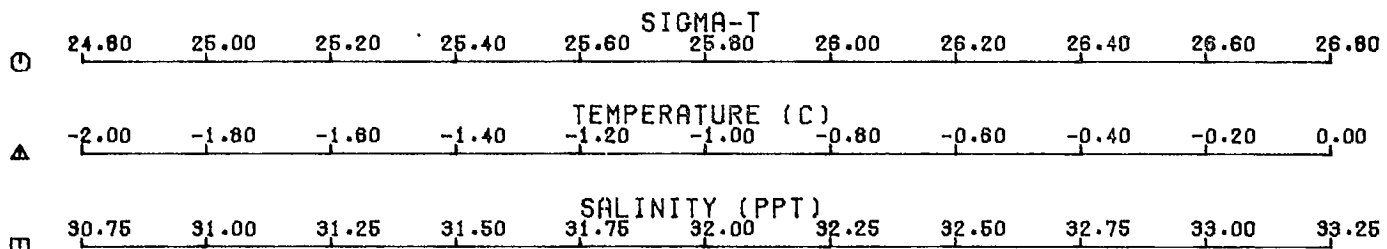

PENNY STRAIT 1976 DATA PROFILES. OKC STATION 11 5 55

LAT 76 42.80 CSTD 803 WATER DEPTH 192.0
 LONG 96 58.70 ICE 0.8 TIME (G.M.T.) 1815
 DATE 22 4 1976

DEPTH	SAL	TEMP	SIGMAT	SOUND
2.0	31.71	-1.65	25.53	1437.0
10.0	31.80	-1.57	25.60	1437.7
20.0	31.83	-1.55	25.62	1438.0
30.0	31.83	-1.55	25.62	1438.1
40.0	31.88	-1.55	25.66	1438.4
50.0	31.92	-1.48	25.69	1438.3
60.0	31.94	-1.44	25.71	1439.3
70.0	31.95	-1.39	25.72	1439.7
80.0	32.01	-1.35	25.75	1440.2
90.0	32.01	-1.35	25.76	1440.3
100.0	32.07	-1.35	25.81	1440.5
120.0	32.12	-1.24	25.85	1441.0
150.0	32.29	-1.08	25.98	1443.0
170.0	32.42	-0.99	26.09	1444.0
185.0	32.46	-0.93	26.12	1444.5

BELOCHER CHAN 1976 DATA PROFILES. AJF STATION 21 1 56

LAT 77 26.00 CSTD 803 WATER DEPTH 59.0
 LONG 95 53.00 ICE 1.3 TIME (G.M.T.) 1500
 DATE 23 4 1976

DEPTH	SAL	TEMP	SIGMAT	SOUND
2.0	31.01	-1.74	24.95	1435.6
5.0	31.03	-1.77	25.03	1435.9
10.0	31.12	-1.75	25.05	1435.9
20.0	31.16	-1.72	25.08	1436.2
25.0	31.20	-1.65	25.11	1436.5
30.0	31.21	-1.61	25.12	1437.0
35.0	31.21	-1.61	25.12	1437.1
40.0	31.22	-1.57	25.13	1437.3
45.0	31.24	-1.53	25.15	1437.4
50.0	31.37	-1.55	25.25	1437.8
55.0	31.40	-1.52	25.27	1438.1

PENNY STRAIT

STATION 11 5 55

1815 GMT 22 4 1976 ICE= 0.8

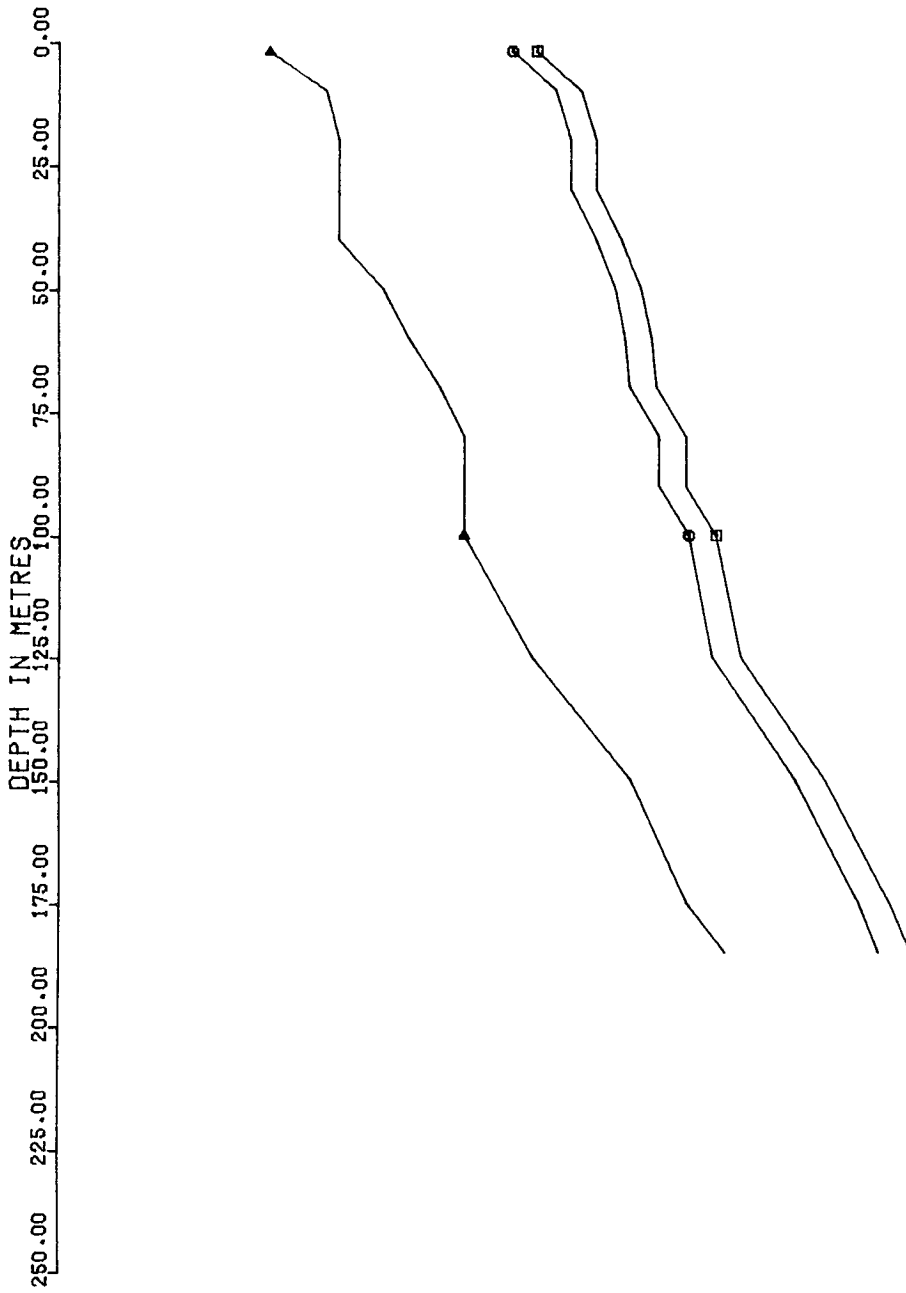
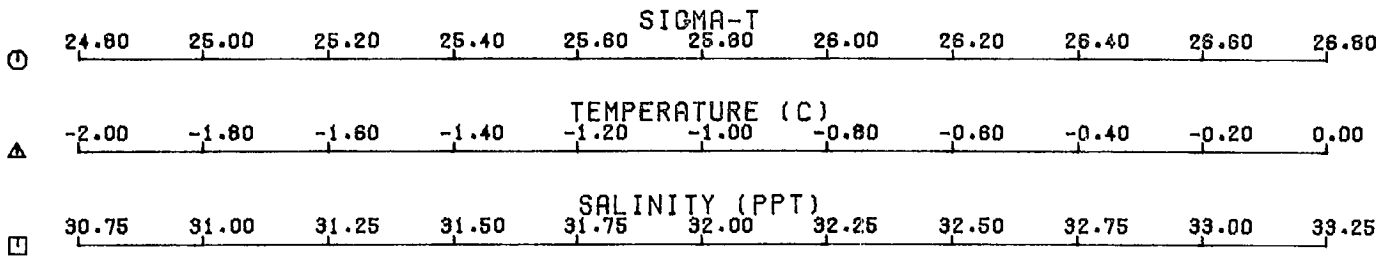

BELCHER CHAN

STATION 21 1 56

1500 GMT 23 4 1976 ICE= 1.3

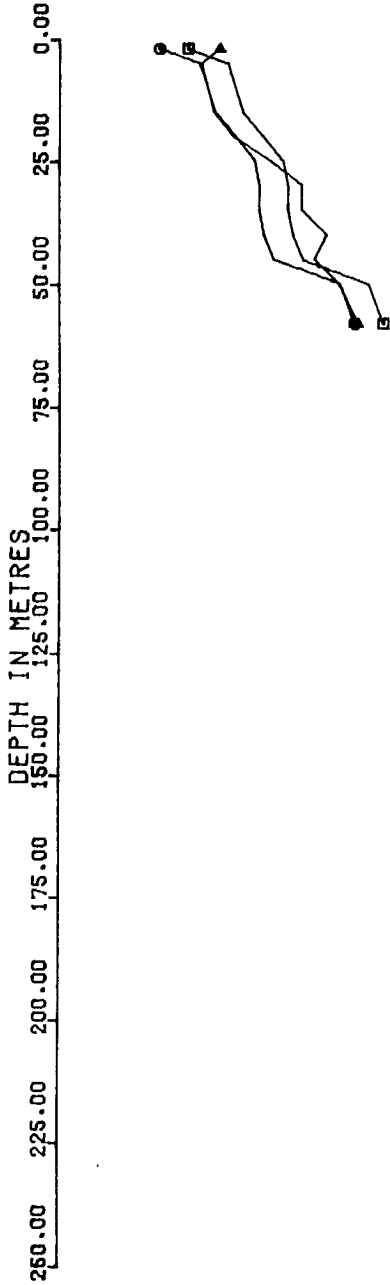
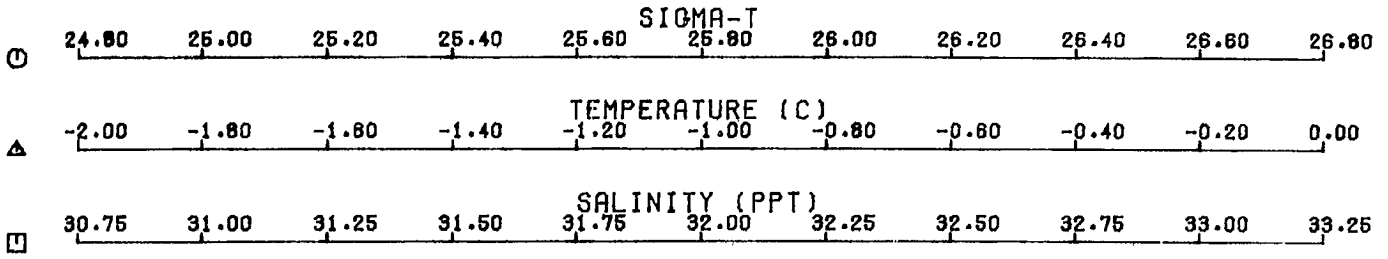

BELCHER CHAN1976 DATA PROFILES. AJR STATION 21 2 57
 LAT 77 26.00 CSTD 803 WATER DEPTH 59.0
 LONG 95 53.10 ICE 1.0 TIME (G.M.T.) 1913
 DATE 24 4 1976

DEPTH	SAL	TEMP	SIGMAT	SOUND
2.0	30.97	-1.70	24.93	1435.8
10.0	30.99	-1.72	24.95	1435.8
20.0	31.08	-1.66	25.02	1436.4
30.0	31.15	-1.61	25.07	1436.0
40.0	31.17	-1.52	25.09	1437.5
50.0	31.20	-1.39	25.11	1438.3
56.0	31.31	-1.44	25.20	1438.4

BELCHER CHAN1976 DATA PROFILES. AJR STATION 22 1 53
 LAT 77 22.40 CSTD 803 WATER DEPTH 68
 LONG 95 57.00 ICE 1.5 TIME (G.M.T.) 1945
 DATE 4 4 976

DEPTH	SAL	TEMP	SIGMAT	SOUND
2.0	31.02	-1.70	24.97	1435.8
10.0	31.10	-1.72	25.03	1436.0
20.0	31.12	-1.74	25.05	1436.1
30.0	31.16	-1.72	25.08	1436.4
40.0	31.34	-1.52	25.23	1437.8
50.0	31.48	-1.44	25.34	1438.5
60.0	31.61	-1.35	25.44	1439.3
70.0	31.80	-1.26	25.59	1440.1
80.0	31.87	-1.21	25.65	1440.6
90.0	32.00	-1.13	25.75	1441.3
100.0	32.12	-1.08	25.85	1441.9

BELCHER CHAN

STATION 21 2 57

1913 GMT 24 4 1976 ICE= 1.0

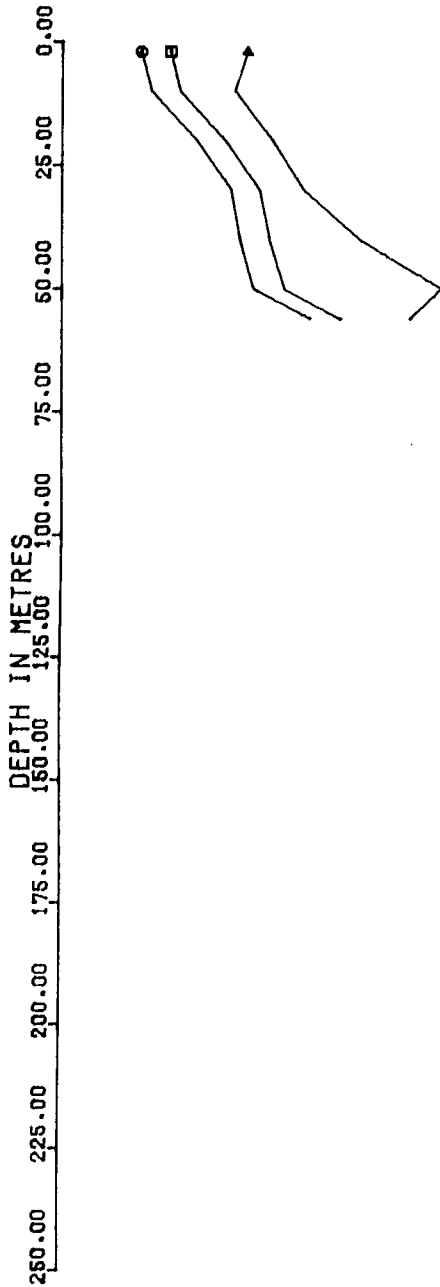
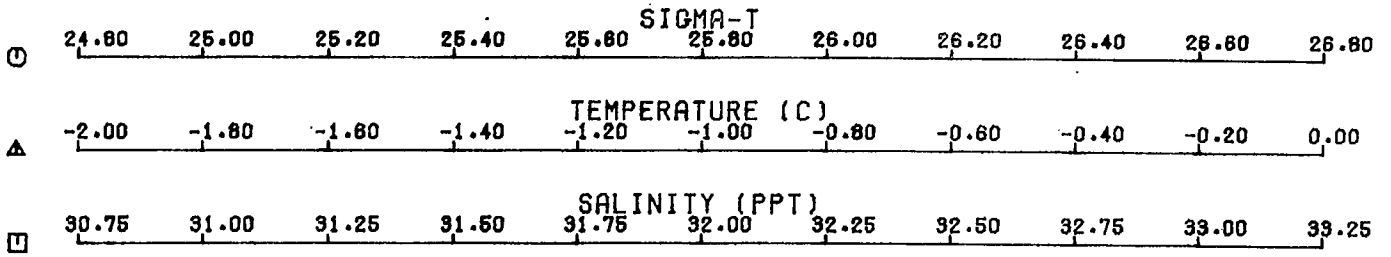

BELCHER CHAN

STATION 22 1 58

1945 GMT 4 4 976 ICE= 1.5

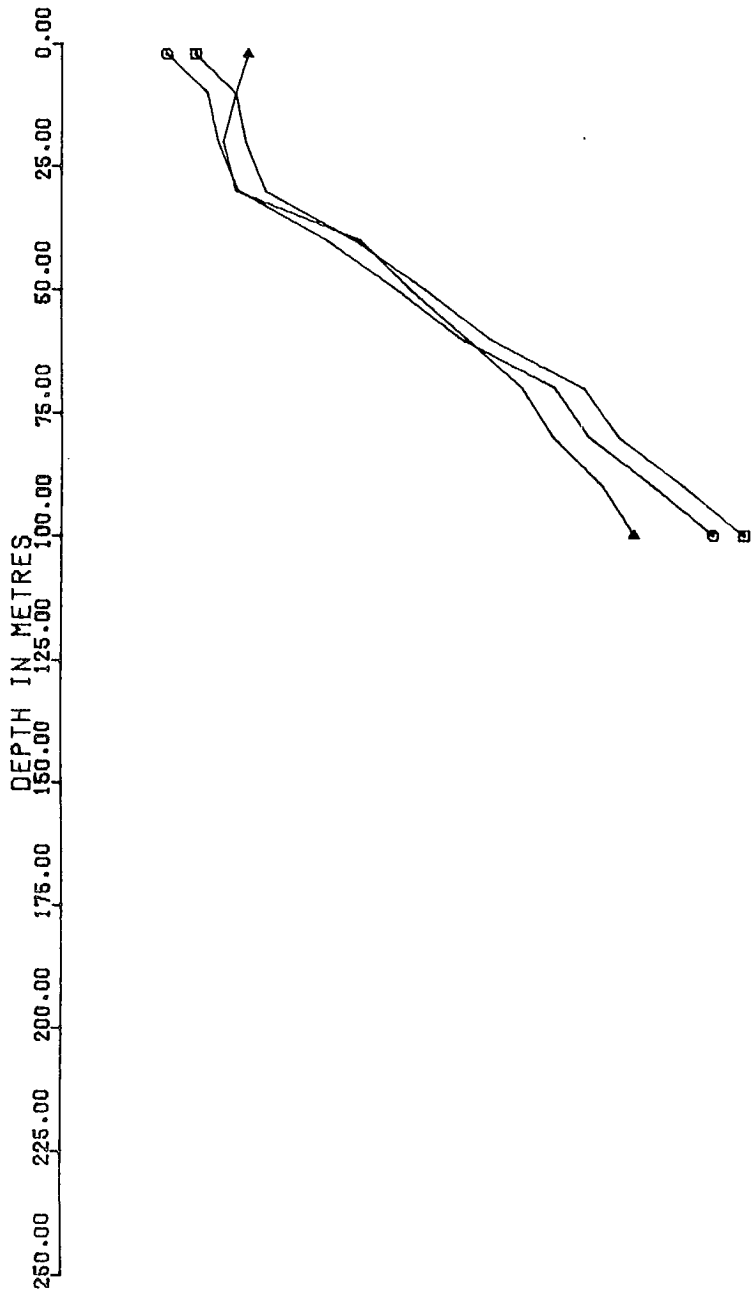
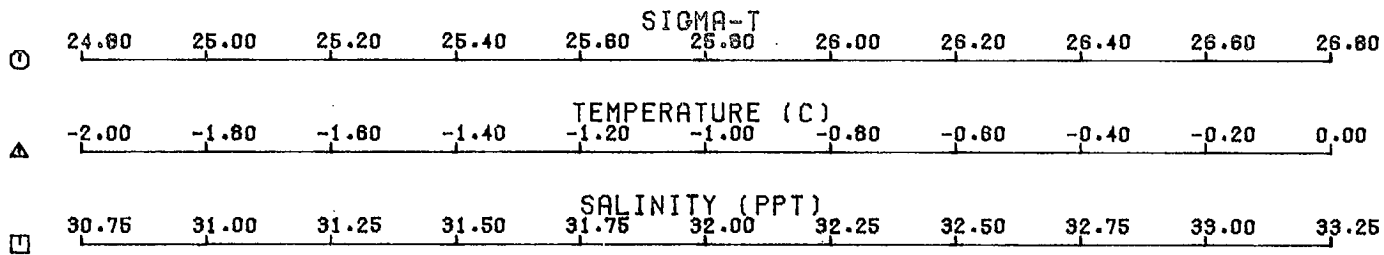

BELOCHER CHAN1976 DATA PROFILES. AJR STATION 23 1 59

LAT 77 18.30 CSTD 803 WATER DEPTH 127.0
LONG 96 1.80 ICF 2.0 TIME (G.M.T.) 2034
DATE 24 4 1976

DEPTH	SAL	TEMP	SIGMAT	SOUND
2.0	31.10	-1.94	25.04	1434.6
5.0	31.12	-1.86	25.05	1435.3
10.0	31.13	-1.81	25.06	1435.6
20.0	31.20	-1.77	25.12	1436.0
30.0	31.34	-1.68	25.23	1436.8
40.0	31.45	-1.57	25.32	1437.7
50.0	31.62	-1.46	25.45	1438.6
50.0	31.74	-1.41	25.55	1439.2
70.0	31.84	-1.35	25.63	1439.7
80.0	31.88	-1.28	25.66	1440.3
90.0	32.01	-1.19	25.76	1441.1
100.0	32.08	-1.15	25.82	1441.3
125.0	32.53	-0.84	26.17	1444.0

BELOCHER CHAN1976 DATA PROFILES. AJR STATION 24 1 50

LAT 77 14.50 CSTD 803 WATER DEPTH 220.0
LONG 96 5.90 ICF 1.5 TIME (G.M.T.) 2122
DATE 24 4 1976

DEPTH	SAL	TEMP	SIGMAT	SOUND
2.0	31.09	-1.88	25.03	1435.1
10.0	31.17	-1.79	25.09	1435.7
20.0	31.34	-1.68	25.23	1436.7
30.0	31.38	-1.61	25.26	1437.2
40.0	31.51	-1.57	25.36	1437.8
50.0	31.63	-1.52	25.46	1438.3
60.0	31.75	-1.37	25.55	1439.4
70.0	31.90	-1.30	25.67	1440.1
80.0	32.08	-1.15	25.82	1441.2
90.0	32.30	-1.02	25.96	1442.4
100.0	32.46	-0.93	25.12	1443.1
125.0	32.68	-0.77	26.29	1444.5
150.0	32.92	-0.57	26.48	1446.2
175.0	32.99	-0.48	26.53	1447.1
200.0	33.05	-0.44	26.57	1447.8

BELCHER CHAN

STATION 23 1 59

2034 GMT 24 4 1976 ICE= 2.0

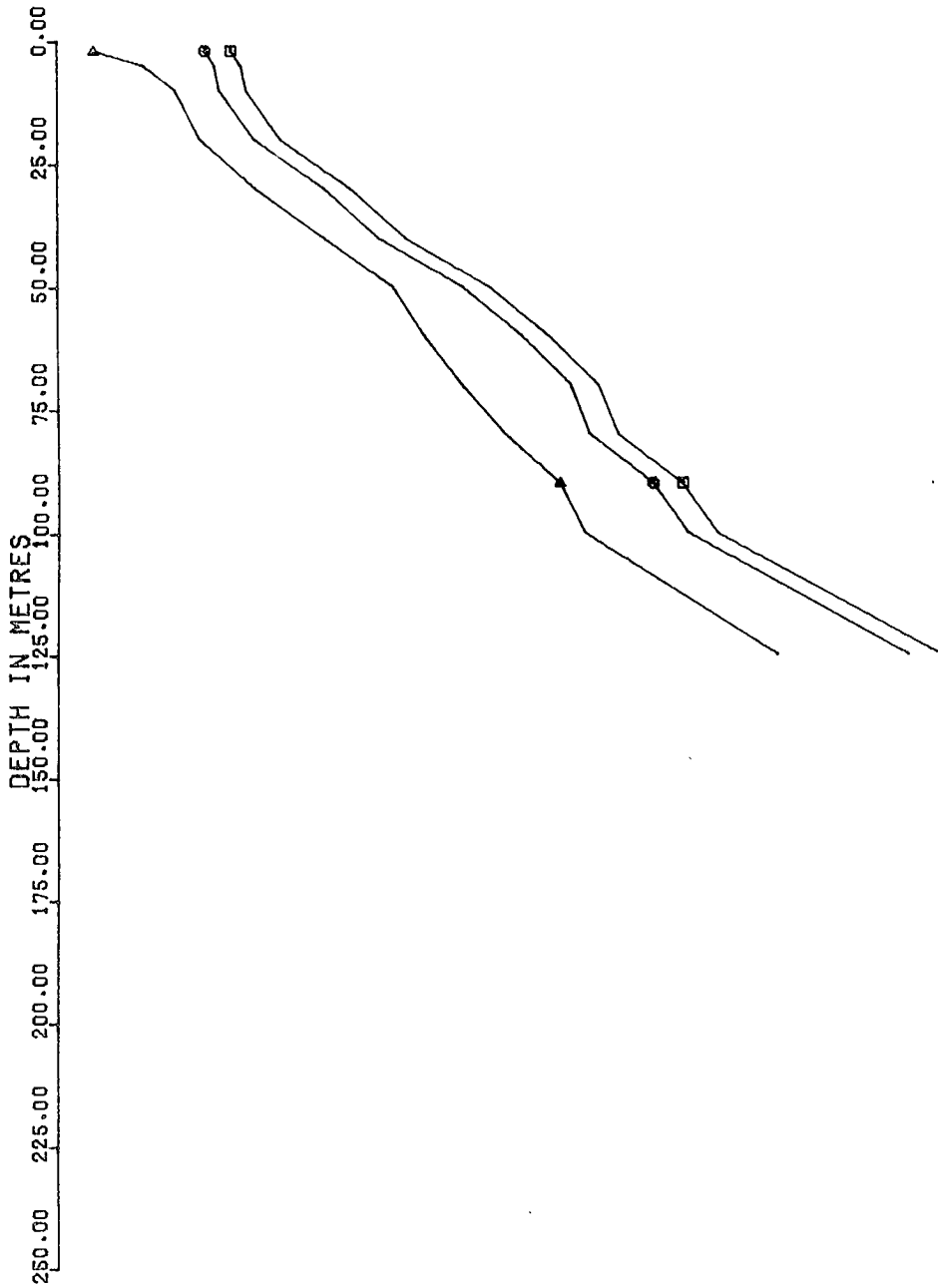
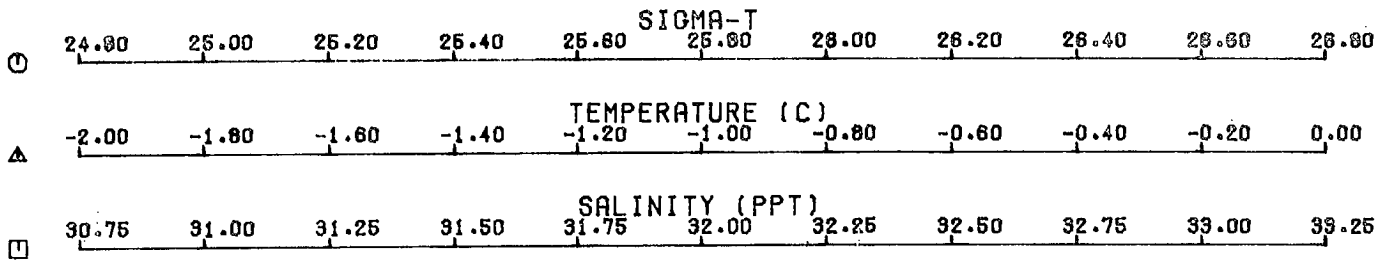

BELCHER CHAN

STATION 24 1 60

2122 GMT 24 4 1976 ICE= 1.5

SIGMA-T

24.80 25.00 25.20 25.40 25.60 25.80 26.00 26.20 26.40 26.60 26.80

TEMPERATURE (C)

-2.00 -1.80 -1.60 -1.40 -1.20 -1.00 -0.80 -0.60 -0.40 -0.20 0.00

SALINITY (PPT)

30.75 31.00 31.25 31.50 31.75 32.00 32.25 32.50 32.75 33.00 33.25

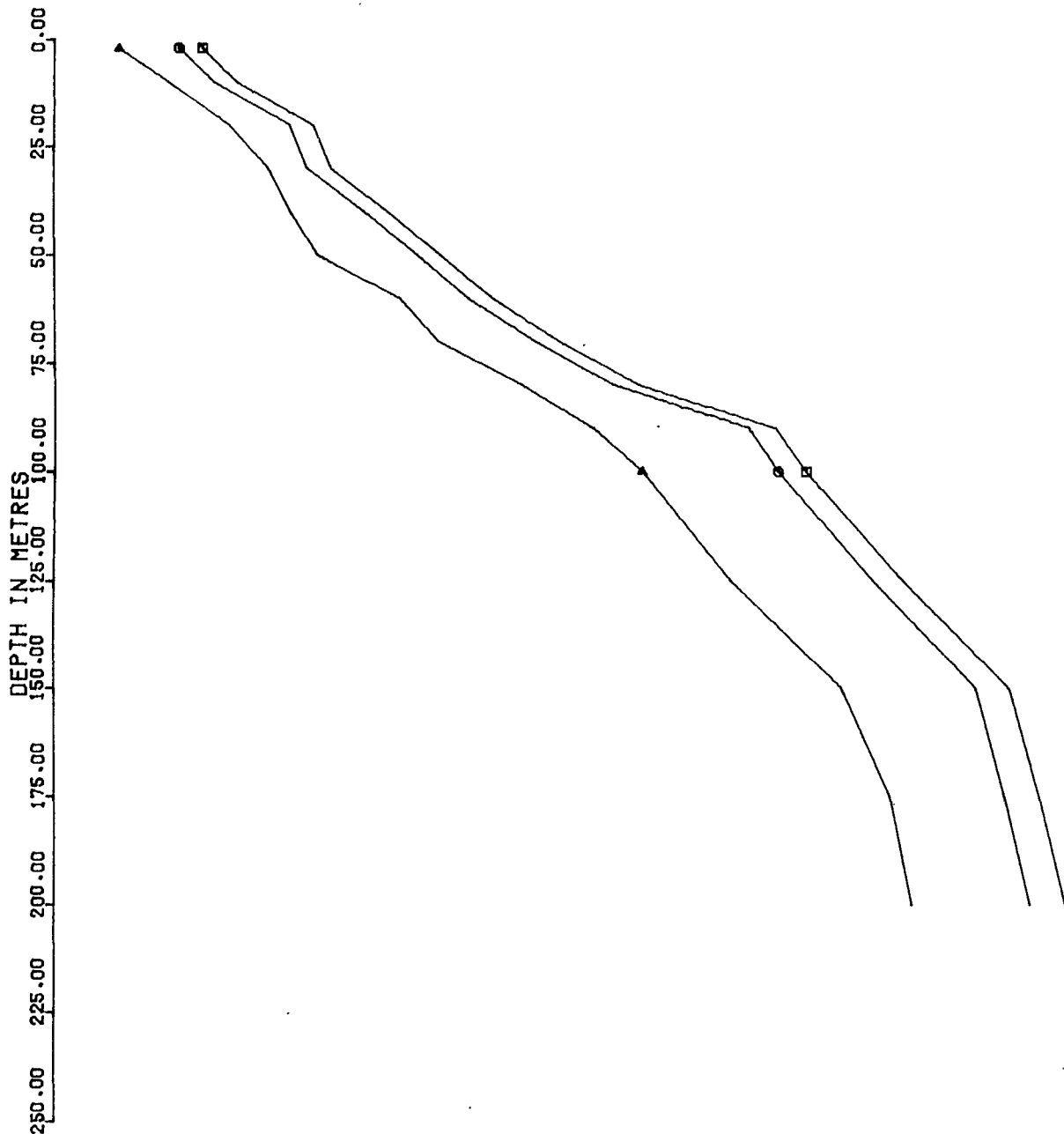

BELCHER CHAN1976 DATA PROFILES. AJR STATION 25 1 61
 LAT 77 7.90 CSTD 803 WATER DEPTH 180.0
 LONG 96 13.00 ICE 1.5 TIME (G.M.T.) 2257
 DATE 24 4 1976

DEPTH	SAL	TEMP	SIGMAT	SOUND
2.0	31.55	-1.83	25.41	1436.0
10.0	31.57	-1.73	25.42	1436.3
20.0	31.62	-1.68	25.46	1437.1
30.0	31.63	-1.63	25.46	1437.5
40.0	31.71	-1.52	25.55	1438.3
50.0	31.81	-1.48	25.61	1438.8
60.0	31.92	-1.37	25.69	1439.6
70.0	32.00	-1.28	25.75	1440.3
80.0	32.08	-1.15	25.82	1441.2
90.0	32.42	-0.99	26.09	1442.6
100.0	32.43	-0.95	26.09	1442.9
125.0	32.52	-0.88	26.16	1443.8
150.0	32.56	-0.82	26.19	1444.6
175.0	32.65	-0.79	26.27	1445.2

BELCHER CHAN1976 DATA PROFILES. AJR STATION 26 1 62
 LAT 77 3.60 CSTD 803 WATER DEPTH 200.0
 LONG 96 17.70 ICE 2.0 TIME (G.M.T.) 2353
 DATE 24 4 1976

DEPTH	SAL	TEMP	SIGMAT	SOUND
3.0	31.13 2	-1.81 2	25.06	1435.5
10.0	31.13 2	-1.81 2	25.11	1435.7
20.0	31.20	-1.77	25.12	1436.0
30.0	31.24	-1.59	25.15	1437.1
40.0	31.70	-1.59	25.52	1437.9
50.0	31.73	-1.46	25.54	1438.7
60.0	31.90	-1.35	25.68	1439.7
70.0	32.00	-1.23	25.75	1440.3
80.0	32.04	-1.21	25.79	1440.9
90.0	32.14	-1.13	25.86	1441.4
100.0	32.26	-1.06	25.96	1442.2
125.0	32.50	-0.86	26.15	1443.9
150.0	32.72	-0.71	26.32	1445.3
175.0	32.76	-0.69	26.35	1445.9
200.0	32.84	-0.66	26.41	1446.5

BELCHER CHAN

STATION 25 1 61

2257 GMT 24 4 1976 ICE= 1.5

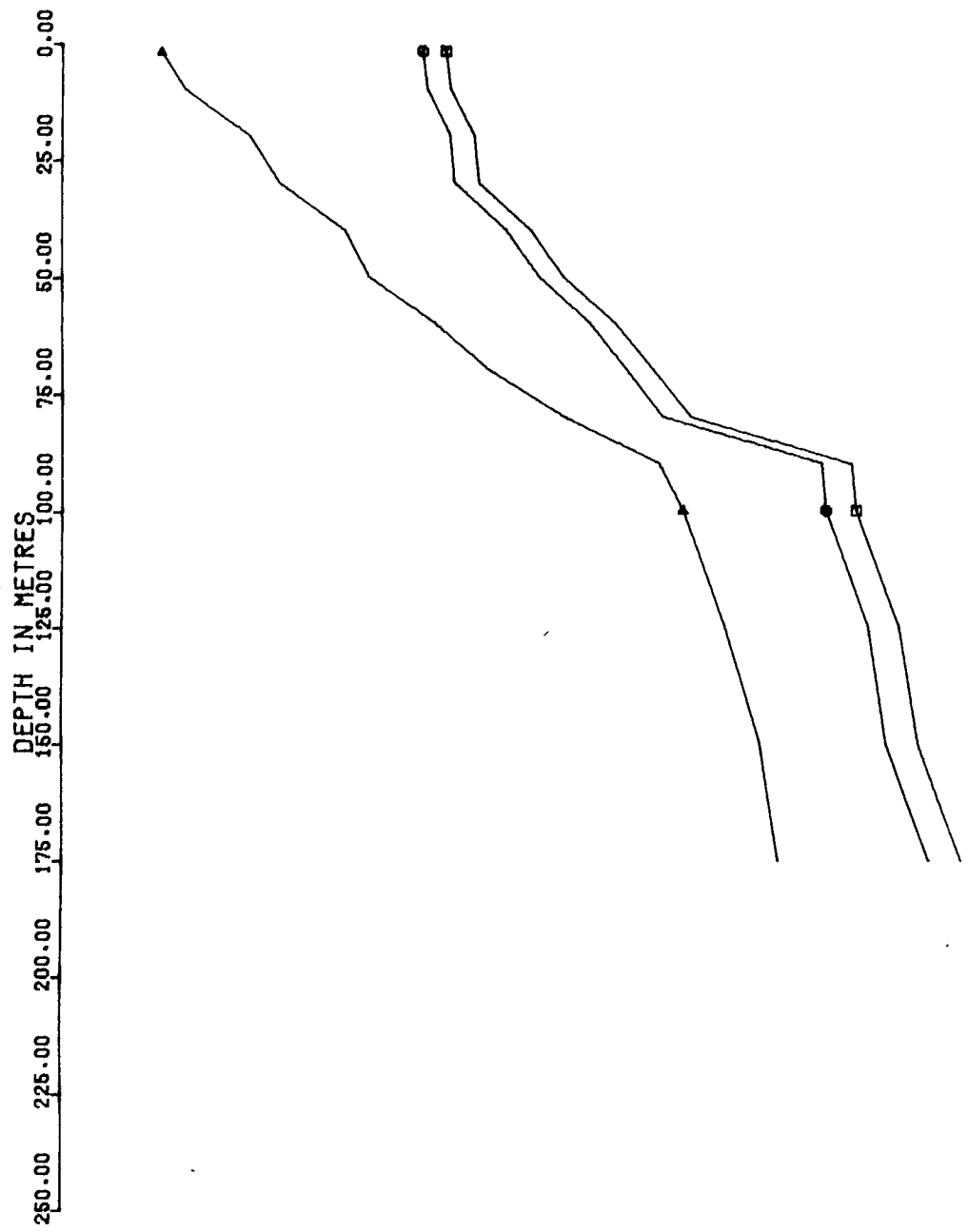
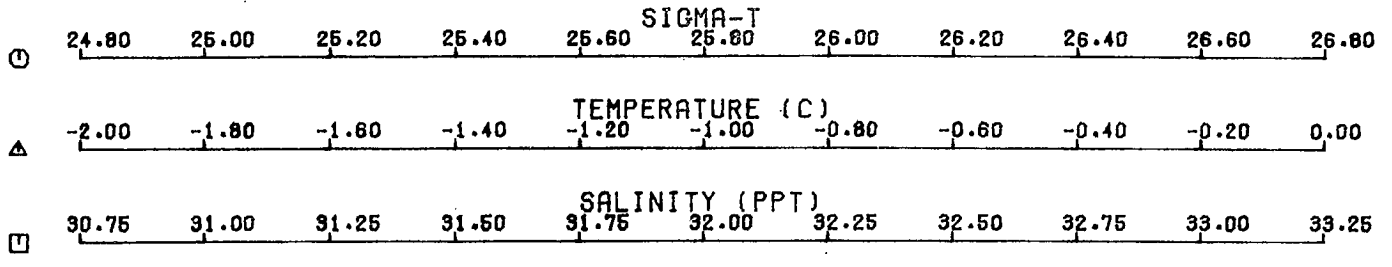

BELCHER CHAN

STATION 26 1 62

2353 GMT 24 4 1976 ICE= 2.0

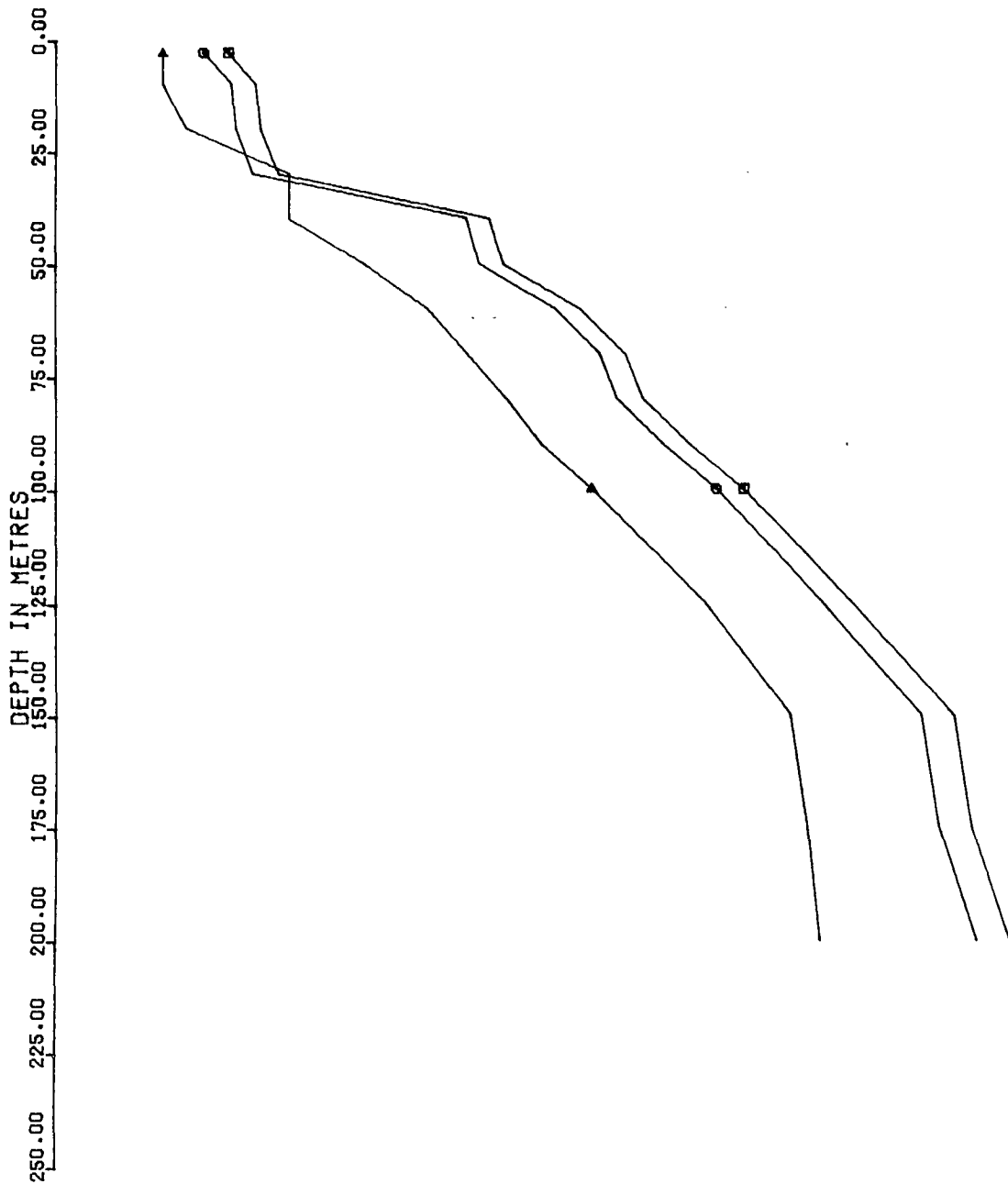
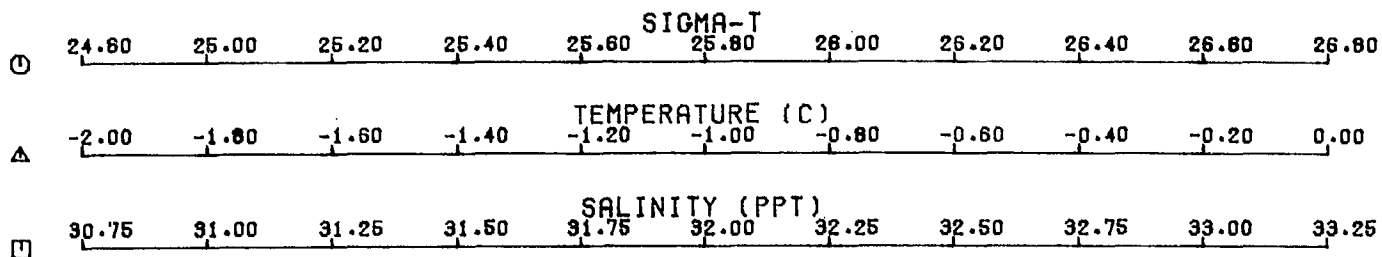

APPENDIX A

CHRONOLOGY OF EVENTS

The following account is included in this report to serve as an indication of how and when the data were collected.

- 1 April Arrived at Resolute.
- 3 April Arrived at Base Camp off Table Island, set up parcoll and started unpacking and setting up gear.
- 4 April Continued organizing gear.
- 5 April Tested Guildline Mark IV.
- 6 April Further tests with Guildline.
- 7 April Still more tests with Guildline and Aanderaa RCM4.
- 8 April Set up 6 stations across Penny Strait.
- 9 April Our contract helicopter (C-GOKC) arrived.
- 10 April Did stations 11 and 12 with Mark IV, but temperature O/P very erratic; returned to camp.
- 11 April Bad weather in survey area; decided to start moorings and 13-hour stations.
- 12 April CELL tent slung out to station 12, moored 12M and 12E by 0330Z (13 April).
- 13 April Started 13-hour station 1730Z.
- 14 April Back to Base Camp.
- 15 April Moved CELL tent and camp to station 14, back to Base Camp after setting up ice station.
- 16 April Did 13-hour station, started mooring 14M and 14E
- 17 April Finished moorings; back to Base Camp.
- 18 April Started CTD transects; completed only stations 11 and 12, because of the weather, before going back to Table Island.
- 19 April No flying - bad weather.
- 20 April Did transect 10 twice, starting with station 16. Could not locate station 15; presumably lost in area of uplifted ice.
- 21 April Started 3rd crossing of transect 10, but system was down due to short in cable. Returned to Base Camp to correct the problem and did transect once from 1900 to 2150 (CST).

22 April Completed final crossing of transect 10. OKC departed for Resolute in afternoon (completed contract). Hydrography recovered tide gauge at Pelham Bay.

23 April Started transect 20 in C-GAJR. Bad weather stopped work after doing station 21.

24 April Did transect 20.

25 April Finished packing gear, left for Resolute in afternoon.

27 April Departed Resolute.

5 May Hydrographic Service recovered 12E and 12M (by 0300Z 6 May).

7 May 14E and 14M recovered; project terminated.

APPENDIX B

PHOTOGRAPHS



Plate 1. Base Camp off Table Island



Plate 2. Transponder used with Mini-Ranger III
positioning system.



Plate 3. Taking CTD cast alongside helicopter.



Plate 4. The first prototype winch: Jiffy auger power head employed to haul up CTD.



Plate 5. Near-surface current profiling arrangement (see Figure 3). CELL tent in background.



Plate 6. Endeco current meter set for mooring. Battery pack is in cage above the instrument.



Plate 7. Remains of hut at Cape Briggs, Grinnell Peninsula, probably built by Belcher during his search for the Franklin expedition. View is towards North-east, with Table Island in the background.

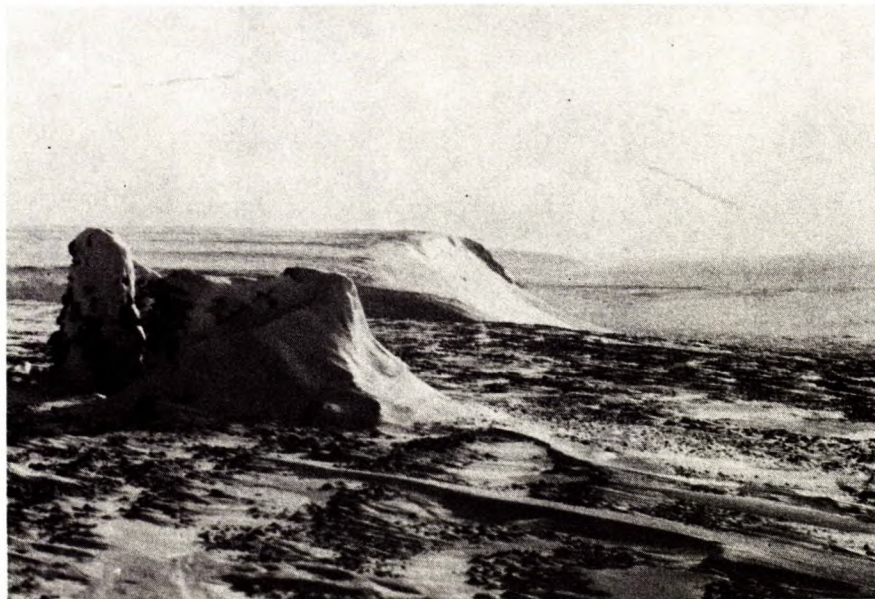

Plate 8. Same as 7, facing West. The walls are constructed of shale and are about .3 - .5m thick and 1.3m high (maximum). The doorway opens to the Southeast.

