



Fisheries and Oceans  
Canada

Pêches et Océans  
Canada

Science

Sciences

## **Canadian Science Advisory Secretariat (CSAS)**

---

**Research Document 2014/024**

**Central and Arctic Region**

### **Modifications to the Campelen 1800 Shrimp Survey Trawl**

T.D. Siferd<sup>1</sup> and G. Legge<sup>2</sup>

<sup>1</sup> Fisheries and Oceans Canada  
Freshwater Institute  
501 University Crescent  
Winnipeg, MB R3T 2N6

<sup>2</sup> Centre for Sustainable Aquatic Resources  
Fisheries and Marine Institute of Memorial University of Newfoundland  
P.O. Box 4920  
St. John's, NL A1C 5R3

---

## Foreword

This series documents the scientific basis for the evaluation of aquatic resources and ecosystems in Canada. As such, it addresses the issues of the day in the time frames required and the documents it contains are not intended as definitive statements on the subjects addressed but rather as progress reports on ongoing investigations.

Research documents are produced in the official language in which they are provided to the Secretariat.

### Published by:

Fisheries and Oceans Canada  
Canadian Science Advisory Secretariat  
200 Kent Street  
Ottawa ON K1A 0E6

[http://www.dfo-mpo.gc.ca/csas-sccs/  
csas-sccs@dfo-mpo.gc.ca](http://www.dfo-mpo.gc.ca/csas-sccs/csas-sccs@dfo-mpo.gc.ca)



© Her Majesty the Queen in Right of Canada, 2014  
ISSN 1919-5044

### Correct citation for this publication:

Siferd, T., and Legge, G. 2014. Modifications to the Campelen 1800 Shrimp Survey Trawl. DFO Can. Sci. Advis. Sec. Res. Doc. 2014/024. iv + 38 p.

---

---

## TABLE OF CONTENTS

ABSTRACT.....	iv
RÉSUMÉ .....	iv
INTRODUCTION .....	1
MATERIALS AND METHODS .....	1
TEST PARAMETERS .....	1
TRAWL MODIFICATIONS .....	2
Footgear.....	2
Float line .....	2
Fishingline.....	2
SINK RATE .....	3
RESULTS AND DISCUSSION.....	3
SINK RATE .....	3
FOOTGEAR.....	3
FLOAT LINE EFFECTS ON GEOMETRY .....	4
FISHINGLINE FLOAT EFFECTS .....	4
PREFERRED RIGGINGS .....	5
MOUTH AREA .....	5
BOTTOM CONTACT.....	5
CONCLUSION.....	5
EXPERIENCE WITH THE MODIFICATIONS.....	6
REFERENCES .....	6
TABLES AND FIGURES.....	7
APPENDIX A. SPECIFICATIONS OF THE FOOTGEAR OF THE STANDARD 1800 CAMPELEN TRAWL.....	13
APPENDIX B. TRAWL GEOMETRY .....	14
APPENDIX C. MODIFIED CAMPELEN TRAWL DETAILED DRAWINGS AND SPECIFICATIONS.....	31

---

## ABSTRACT

Initial Northern Shrimp Research Foundation (NSRF)–Fisheries and Oceans Canada (DFO) bottom trawl surveys conducted using the standard Campelen 1800 survey trawl in the new Resolution Island survey area of eastern Hudson Strait experienced a high tear-up rate. This was costly both in time and maintenance, but most importantly affected survey coverage and results. The standard Campelen trawl needed modifications for efficient sampling in this survey area. Modifications considered were increasing the diameter of the footgear, floating the fishingline, adding floatation along lower belly panel seams and putting a restrictor strap on the warps. These modifications, except for the restrictor strap, were tested in a flume tank to observe their effect on trawl geometry and to adjust the floatation on the footgear to reduce sinking in mud but still maintain bottom contact. Results of the testing and final configuration of the trawl are presented. The 21” footgear with 47 floats on the fishingline and float line along the first and second bellies seam line were put into practice in the 2008 and 2009 surveys. Tear-ups caused by bottom contact were reduced to zero with these modifications in place.

### **Modifications apportées au chalut de relevé Campelen 1800 utilisé pour la crevette**

## RÉSUMÉ

Les relevés initiaux au chalut de fond effectués par la Northern Shrimp Research Foundation (NSRF) et Pêches et Océans Canada (MPO) au moyen du chalut à relevés Campelen 1800 standard dans la nouvelle zone de relevé de l'île Resolution, dans l'est du détroit d'Hudson, ont connu un taux élevé de déchirures. Cela a entraîné des pertes de temps et nécessité de l'entretien, mais plus important encore, a eu des répercussions sur la couverture et sur les résultats des relevés. Il fallait modifier le chalut Campelen standard pour permettre un échantillonnage efficace dans cette zone de relevé. Les modifications envisagées étaient une augmentation du diamètre du bourrelet, le fait de faire flotter la ligne de pêche, l'ajout de matériel flottant le long des coutures des panneaux inférieurs des ventres, et l'ajout d'une courroie de restriction sur les funes. Ces modifications (à l'exception de la courroie de restriction) ont été testées dans une citerne antiroulis afin d'observer leur effet sur la géométrie du chalut et d'ajuster la flottaison du bourrelet afin de réduire qu'il s'enfonce dans la boue tout en maintenant un contact avec le fond. Les auteurs présentent les résultats des essais et la configuration finale du chalut. Le chalut comportant un bourrelet de 21 po avec une ligne de pêche munie de 47 flotteurs, et de la ligne de flottaison le long de la ligne de couture entre le premier et le deuxième ventre a été mis en pratique pendant les relevés de 2008 et de 2009. Grâce à ces modifications, les déchirures causées par les contacts avec le fond ont été réduites à zéro.

---

## INTRODUCTION

In 2006, the Northern Shrimp Research Foundation (NSRF) in partnership with Fisheries and Oceans Canada (DFO) began an annual series of stock assessment bottom trawl surveys in the new Resolution Island survey area (RISA; 60°30'-63°N, 63°-66°W) of eastern Hudson Strait. The trawl chosen for the survey was the standard Campelen 1800 survey trawl used by DFO in its surveys off Newfoundland and Labrador since 1995 (McCallum and Walsh 1996) with the current standard rigging documented in Walsh et al. (2009).

The first two survey years, 2006 and 2007, in RISA produced high tear-up rates up to 12.9%. Tear-ups increase the cost of the survey through the replacement of gear and the ship time required to repeat a station or relocate to an alternate station. Tear-ups are difficult on the crew having to continually repair the trawl but most importantly, affected the scientific data from unusable sets and reduced areal coverage. The NSRF requested that modifications to the trawl be made to reduce the cost and at the same time improve the survey.

The main factors thought to contribute to the high tear-up rate in RISA were the door and/or footgear sinking into soft bottoms bringing the lower bellies into contact with the bottom. Several modifications were suggested that might reduce the problem:

1. increase the shoe width of the doors,
2. increase the diameter of the footgear (i.e., rockhopper disks),
3. lighten the footgear by adding floats to the fishingline,
4. add floatation to the bellies and
5. use a restrictor strap (Engås and Ona 1991, 1993; Walsh and McCallum 1996) to help prevent the doors from falling over.

Of these, 2-4 could be modelled and tested in a flume tank prior to use at full scale.

In 2008, the Centre for Sustainable Aquatic Resources (CSAR), Marine Institute, Memorial University was contracted to provide flume tank testing facilities and expertise as it relates to the modification of the Campelen 1800. Utilizing an accurately-constructed scale model of the Campelen 1800, proposed modifications were tested to determine the possible effects these proposed changes might have on the geometry of the trawl.

## MATERIALS AND METHODS

### TEST PARAMETERS

To minimize potential damage to the full scale survey trawl a number of changes were proposed and subsequently modeled in the flume tank. These include the following.

1. Replacement of the 35 cm (hereafter referred to as 14") diameter rockhopper disks with 46 cm (hereafter referred to as 18") disks.
2. Replacement of the 14" diameter rockhopper disks with 53 cm (hereafter referred to as 21") disks.
3. The addition of floats to the fishingline to raise the fishingline further from the seafloor.
4. The addition of float line to the lower rib line in the first and second bellies to raise the bellies further off of the seafloor.

---

Several of these proposed changes are commonly used in commercial fishing trawls used on the east coast of Canada.

## **TRAWL MODIFICATIONS**

DFO-Newfoundland and Labrador Region's model of the Campelen trawl labelled as M-80 made by CSAR and stored at the Marine Institute was used with their permission for the testing conducted here. As a result of changes made to the survey trawl since the time that the model was originally built, some minor modifications to the model were required to produce an exact model of the standard Campelen specifications used today (Appendix A). The most significant change was the replacement of the travel wire with a travel chain which required disassembly of the footgear to drill a larger hole through the rockhopper disks.

### **Footgear**

Two sets of modified model footgear were constructed by Harold DeLouche and George Legge of CSAR with rockhopper disks of larger diameter than that of the standard Campelen 1800 survey trawl (Figure 1). These replacement model footgears represented rockhopper disks 18" and 21" in diameter, as opposed to the 14" disks typically used on the existing survey trawl. As well, larger bunt bobbins had to be fabricated to match the size and weight of each particular rockhopper diameter being tested. Typical footgear construction details can be found in Appendix A.

The theoretical weight calculations assumed that the replacement disks are of the same density and thickness as the 14" disks. Increased disk volume provides for the additional weight increase. Model wet weights were confirmed based on this calculation. Corresponding full scale seawater weight and model weights for each of the three disk sizes are listed in Table 1.

The bobbin chain lengths for both of the modified model footgear were also altered proportionately. The 18" footgear utilized a full scale equivalent 505 mm bobbin chain (effective length of 253 mm) and the 21" footgear utilized a 590 mm bobbin chain (effective length of 295 mm). Comparatively, the standard 14" footgear utilizes a 393 mm bobbin chain, having an effective length when rigged of 197 mm.

### **Float line**

The use of a float line, not traditionally used on the Campelen 1800 survey trawl, was evaluated on all three different footgear sizes. Float lines are difficult to simulate in model size, as entrapped air is not completely removed at the low water pressures experienced in a flume tank. As a result, small rigid floats were substituted and spaced to recreate the buoyancy specified by float line manufacturers (Figure 2). For the Campelen, a float line having a buoyancy of 0.75 kg/m was simulated. For the standard 14" rig, the float line was positioned on the lower rib line of the first belly. For the 18" and 21" footgears the float line was attached on the lower rib line of both the first and second bellies.

### **Fishingline**

The use of floats on the fishingline was evaluated for the 14", 18" and 21" footgears tested. All trawls were tested with 39 floats along the fishingline, a "normal" door spread of 51 m and a common tow speed of 3.0 knots.

No changes were made to the mesh or floatation along the headrope of the trawl.

---

## **SINK RATE**

Since standardization of both gear and gear procedures play an important role in survey accuracy, it was suggested that the sinking rate of the trawl should be evaluated. The rate of descent of a survey trawl can have a significant effect on the catch rate and changes to the gear can impact the descent rate, hence the catch and composition. Given the nature of the changes proposed for the survey trawl (i.e., various weight/buoyancy combinations) a test plan was devised to measure the rate of descent under controlled experimental conditions.

The model trawl was shot away at a tow speed of 1 knot but not lowered to the bottom of the flume. Tow points, which act as an adjustable connection point within the flume tank, were fixed at a known position above water. Once the gear had stabilized within the flume, the position of the bosum rockhopper disks was measured for height above the flume tank ground plane (or in full scale terms, the seafloor). The gear was then lowered by the tow points at a constant rate of descent. The tow points, in essence, simulate the trawl doors being lowered through the water column. The time required for the trawl to touch down was recorded and the resulting rate of descent was calculated. The gear was considered “on bottom” when the bosum made contact with the ground plane.

## **RESULTS AND DISCUSSION**

A total of 34 rigs were evaluated during the February 27-29, 2008 test period (Table 2). Apart from standard trawl geometry measurements there were 14 rigs tested specifically to determine whether the changes made to the trawl would have an effect on the trawl descent rate during the gear shooting process. Also, of the 20 remaining configurations, 7 included additional trawl geometry measurements which would allow a direct comparison of leading edge mouth shapes and positions, providing an accurate indicator of trawl mouth perimeter, mouth area and relative gear position changes. Further explanation of each is provided below.

## **SINK RATE**

Sink rate results are presented in model values only and it is recognized that the depth, time, and tow point rate of descent are not similar to that of any real world scenario (Table 3). These tests were not designed to determine “real-world” descent rates and are based upon one trial per rig only. It was intended to show the relative drop rate of the models in a controlled setting to determine whether to expect large changes in the sink rate in the full scale trawl.

Predictably, it appears the rate of descent is affected by the number of floats and the net weight of the footgear. As an example, comparing Rigs 6 and 32, it is apparent that the standard 14” gear used in Rig 6 descended at a slightly slower rate than that of the heavier 21” gear used in Rig 32. Contrary to this, the intermediate 18” gear descended at a rate slightly slower than that of the standard 14” gear. While this appears to contradict the gear weight as being the major contributor to sink rate it may be considered also a function of increased gear size hence increased resistance to sinking, but more likely the result of minor measurement error or other experimental limitations. In all cases, the rates of descent were within  $\pm 4\%$  of the standard Rig.

## **FOOTGEAR**

For these experiments Rig 1 is considered the standard Rig. The gear is fitted with its typical 14” rockhopper footgear, and a “normal” door spread of approximately 51 m, the observed mean door spread of the full scale trawl used during the 2007 NSRF-DFO survey. The same door spread parameters were applied to the 18” footgear (Rig 14) as well as the 21” footgear (Rig 33). By applying the same door spread to all three rigs it is possible to establish the anticipated

---

full scale door spread change via the bridle tension. Theoretically, if the bridle tension were to increase, the door spread would decrease, as the inward pulling component of the bridle tension increases. In the same manner, a decrease in bridle tension would result in an increase in door spread.

During this trial, no significant change in bridle tension was recorded between the three footgear sizes evaluated. This allows a direct comparison of results recorded for Rigs 1, 14, and 33. The results are found in Appendix B. Of significant value is the change in fishingline position between the 3 rigs, with the belly heights becoming progressively higher as rockhopper disk size is increased. For ease of comparison, a graphical representation of the mouth area at a speed of 3 knots is shown in Figures 3 and 4 for the three rigs listed, with Rig 1 shown in black.

Overall trawl shape changed very little, with changes in footgear size. The height of the fishingline and belly heights became progressively larger with footgear diameter increases as presented in Figure 5.

### **FLOAT LINE EFFECTS ON GEOMETRY**

Results can be found in Appendix B. For Rig 1, with 14" rockhopper, there was no significant change in trawl geometry as a result of the use of the float line when tested at 3.0 knots. As a result, the float line length was increased for the two remaining footgear sizes and terminated at the end of the second belly.

In Rigs 19 and 21, the effects of the float line on the 18" footgear were evaluated. As with the 14" footgear, there appeared to be little benefit of using a float line when tested at 3 and 3.75 knots. The same result was observed for the 21" footgear which was evaluated through testing of Rigs 26 and 31, again at 3.0 and 3.75 knots.

To be certain that the float line was having little effect throughout the speed range; it was evaluated at a speed of 1 knot for Rigs 26 and 31. The rib line height was measured at three positions; at the lower rib line of the first belly, at the end of the first belly and at the end of the second belly. With the float line attached, the rib line had raised approximately 6 cm full scale at the two forward points and remained at the same vertical height at the end of the second belly, displaying little buoyant value in flume tank trials at slow speed.

With no water flow the float line kept the bellies and cod end from sinking to the bottom. If the trawl was stopped during the tow this might help keep the bellies off the bottom and thereby snagging. However, the effect would likely be limited and dependent on very little weight being on the mesh.

### **FISHINGLINE FLOAT EFFECTS**

The use of floats on the fishingline was evaluated in Rigs 12, 21 and 24 for the 14", 18" and 21" footgears tested, respectively. The larger 21" rockhopper, utilized in Rig 24, had an increased delta plate size due to the restrictive nature of the typical smaller delta plate used on the existing Campelen 1800. The delta plate was increased in size by a factor of 1.5 (21"/14") and the additional delta plate length increase was compensated for by shortening of the flying wing chain by the difference in effective length. With no floats on the fishingline, the drag of the rockhopper disks on the bottom caused the travel chain to roll forward which in turn brings the fishingline down until stopped by the top of the disks. This effect occurred in all three footgear sizes tested. Adding floatation to the fishingline overcame the twist of the disks resulting in vertical toggle chains (Figure 6). This improved fishingline clearance from the seafloor which translated directly into an improved belly clearance (Table 4 and Figure 7). In all cases, when



---

referenced against the standard rig (Rig 1) clearances increased with the addition of fishingline floats, and by greater amounts as footgear size increased.

## **PREFERRED RIGGINGS**

The numerous rigs tested with the 18" and 21" footgears resulted in preferred riggings which, in terms of trawl geometry, provide reasonable bottom clearance versus the standard rig tested.

For the 18" footgear, the preferred rig was identified as Rig 19 which was fitted with 39 floats on the fishingline. The variation between Rig 19 and the standard rig (Rig 1) is shown graphically in Figure 8. An increase in fishingline height is noticeable, particularly in the bosom section, this increased height results in a slightly higher headline height as well. Wing opening is affected very little in comparison to the standard rig.

For the 21" footgear, the preferred rig was identified as Rig 31 which was fitted with 47 floats on the fishingline. The variation between Rig 31 and the standard rig (Rig 1) is shown graphically in Figure 9. The 21" footgear provides a greater fishingline clearance from wingtip to wingtip, and a slightly higher headline height than the standard rig. Wing opening remains practically the same as in the standard rig.

## **MOUTH AREA**

Several of the rigs tested had additional geometry data collected at 3.0 knots. These data were used to produce the graphical representations presented in Figures 3, 4, 8 and 9. The geometry data were used in an engineering drawing software package (Autocad® 2006) to create a profile drawing of the trawl mouth. Apart from the resulting graphic, the drawing provides specific information about the resulting two-dimensional shape, specifically the projected area and circumference. This information is shown in Table 5. Despite slight changes in projected area from rig to rig, the projected circumference remains relatively constant.

## **BOTTOM CONTACT**

The addition of excess floatation to the fishingline caused an undesirable result in flume tank trials at higher tow speeds. Fishingline floats can effectively lighten the footgear, causing bottom contact to be lost, specifically in the bosom and to a lesser extent in the wings. Most rigs tested had fishingline floats positioned away from these sensitive areas, to minimize bottom contact loss. Two rigs were tested with an increased number of floats than that of the more preferred rigs described above. Rigs 17 and 29 were tested with 7 and 8 more floats, respectively, positioned on the fishingline, but again distributed in areas away from the bosom and wing tips. The result was a regular momentary loss of bottom contact in the bosom and near the wing tip, at speeds of 3.75 knots. If the application of floats to the fishingline is planned for the full scale trawl, then the effect of excess floatation should be considered and the gear should be monitored to ensure good bottom contact.

## **CONCLUSION**

The damage a trawl receives during fishing can never be eliminated. The effects of low-bottom clearances on rough unstable bottom types will certainly determine the number of tear-ups a trawl will be subjected to.

The use of float lines on the lower rib line did not seem to provide any obvious advantages in maintaining or controlling trawl geometry on the flume tank Campelen 1800 model. This was demonstrated both at low speed (1 knot) as well as high speed (3.75 knots).

---

In flume tank trials, the increase in diameter of footgear components demonstrated a significant positive effect on lower belly clearances. In the same manner, the use of floats on the fishingline, which is common practice in commercial fisheries, had a beneficial result with respect to belly to seafloor clearances. The proper balance and positioning of floats is critical to maintain good bottom contact while ensuring reasonable belly clearance and ultimately reduced trawl damage. Use of these modifications during flume tank trials did not severely affect trawl geometry measurements.

## **EXPERIENCE WITH THE MODIFICATIONS**

In 2008, during the shakedown trials just prior to the survey, attempts were made by the crew of the Cape Ballard to use a restrictor strap between the warps ahead of the doors. This modification had been used with an 1800 Campelen trawl in Norway trawl survey (Engås and Ona 1991, 1994; Aschan and Sunnanå 1997) and trialed in Newfoundland (Walsh and McCallum 1996). The strap proved difficult to position and was abandoned early in the trials. More time than was available during the shakedown trials would be required to find the optimal position and length for the strap to function properly. A dedicated configuration cruise would be required if the strap is to be used in the future.

The preferred modifications tested in the flume tank (i.e., 21" rockhopper disks with 47 8-inch floats distributed on the fishingline and a polypropylene float line along each lower belly seam) were incorporated into the Campelen trawl used in the RISA survey conducted in 2008. No bottom contact tear ups of the modified trawl were recorded in 2008. One tear up (all upper panels torn) did occur caused by strong tidal currents putting too much strain on the twine. It could not be through bottom contact as monitoring equipment showed the trawl was never on bottom. The area surveyed with the modified trawl was expanded in 2009 to include both RISA and the area to the east, Shrimp fishing Area (SFA) 2 Exploratory (SFA2EX). No tear ups of any sort were recorded in either survey area. These modifications were so successful in reducing tear ups that it was felt the other modifications considered previously (i.e., the restrictor strap and wider door shoes) would not be required.

The specifications of the modifications included in the Campelen trawl used for NSRF-DFO surveys conducted in RISA and SFA2EX survey areas are shown in Appendix C.

## **REFERENCES**

- Aschan, M., and Sunnanå, K. 1997. Evaluation of the Norwegian shrimp survey conducted in the Barents Sea and the Svalbard area 1980-1997. ICES CM1997/Y:07. 24 p.
- Engås, A., and Ona, E. 1991. A method to reduce survey bottom trawl variability. ICES CM1991/B:39. 6 p.
- Engås, A., and Ona, E. 1993. Experiences using the constraint technique on bottom trawl doors. ICES CM1993/B:18. 10 p.
- McCallum, B.R., and Walsh, S.J. 1996. Groundfish survey trawls used at the Northwest Atlantic Fisheries Centre, 1971-present. NAFO SCR Doc. 96/50. Ser. No. N2726. 18 p.
- Walsh, S.J., and McCallum, B.R. 1996. Preliminary analysis of controlling the geometry of a bottom survey trawl using the restrictor rope technique: effect on trawl performance and catchability of groundfish. NAFO SCR Doc. 96/53. Ser. No. N2729. 15 p.
- Walsh, S.J., Hickey, W.H., Porter, J., Delouche, H., and McCallum, B.R. 2009. NAFC Survey Trawl Operations Manual: Version 1.0. Fisheries and Oceans, Northwest Atlantic Fisheries Centre, Newfoundland Region, St. John's. 195 p.

## TABLES AND FIGURES

*Table 1. Full scale weights for the three sections and total weight of the footgear in seawater and their corresponding model weights. Note that the table does not include the weight of the toggle chains for each section.*

R/hopper Size	Flying Wing		Quarter		Bosum		TOTAL	
	Full scale (kg)	Model (kg)	Full scale (kg)	Model (kg)	Full scale (kg)	Model (kg)	Full scale (kg)	Model (kg)
14"	42.56	0.304	122.75	0.877	132.92	0.949	463.54	3.311
18"	47.58	0.340	133.44	0.953	147.88	1.056	509.93	3.642
21"	52.25	0.373	143.24	1.023	161.60	1.154	552.56	3.947

*Table 2 Configuration of the model Campelen trawls tested (Rig) in the flume tank.*

Rig #	Rockhopper Size			Door Spread (m)	Float Line Fitted	Fishingline Floats	Sink Time Recorded	Geometry Measurements
	14"	18"	21"					
1	✓			51		0		✓
2	✓			49		0		✓
3	✓			47		0		✓
4	✓			44		0		✓
5	✓			41		0		✓
6	✓			43		0	✓	
7	✓			43		46	✓	
8	✓			51		46		✓
9	✓			51		39		✓
10	✓			43		39	✓	
11	✓			43	✓	39	✓	
12	✓			51	✓	39		✓
13		✓		43		0	✓	
14		✓		51		0		✓
15		✓		41		0		✓
16		✓		41		46	✓	
17		✓		51		46		✓
18		✓		43		39	✓	
19		✓		51		39		✓
20		✓		43	✓	39	✓	
21		✓		51	✓	39		✓
22			✓	43	✓	39	✓	
23			✓	43	✓	39	✓	
24			✓	51	✓	39		✓
25			✓	43	✓	47	✓	✓
26			✓	51	✓	47		✓
27			✓	47	✓	47		✓
28			✓	43	✓	55	✓	
29			✓	51	✓	55		✓
30			✓	43		47	✓	
31			✓	51		47		✓
32			✓	43		0	✓	
33			✓	51		0		✓
34			✓	41		0		✓

Table 3. Sink rate of model Campelen trawls in the flume tank.

Rig #	Bosum height above Bottom (m)	Time to Bottom (seconds)	Speed of Descent (cm/s)	Variation from Standard (%)
6	1.68	61	2.75	
7	1.90	71	2.68	-2.8
10	1.88	68	2.76	0.4
11	1.85	68	2.72	-1.2
13	1.61	59	2.73	-0.9
16	1.81	68	2.66	-3.4
18	1.77	67	2.64	-4.1
20	1.79	67	2.67	-3.0
22	1.75	65	2.69	-2.2
23	1.68	62	2.71	-1.6
25	1.71	63	2.71	-1.4
28	1.75	66	2.65	-3.7
30	1.70	61	2.79	-1.2
32	1.39	49	2.84	3.0

Table 4. Height above the seafloor of the standard Campelen with no floats on the fishingline and for the three footgear sizes tested (i.e., 14", 18" and 21") with 39 floats along the fishingline.

Section	Height above Seafloor (cm)			
	Rig 1 14" No Floats	Rig 12 14" 39 Floats	Rig 21 18" 39 Floats	Rig 24 21" 39 Floats
Fishingline	30	42	54	66
Aft of Belly 1	42	54	66	72
Aft of Belly 2	114	120	132	138

Table 5. Projected mouth area and circumference of selected Rigs tested.

Rig	Projected Area (m <sup>2</sup> )	Variation from Standard (Rig1)	Projected Circumference (m)	Variation from Standard (Rig1)
1	62.7		39.3	
14	61.8	-1.5%	39.3	0.0%
19	63.0	0.4%	39.5	0.5%
24	60.7	-3.2%	39.3	0.0%
26	59.6	-4.9%	39.3	0.0%
31	60.7	-3.2%	39.2	-0.3%
33	62.0	-1.1%	39.4	0.3%



*Figure 1. Center bosom section of the three model footgears tested representing 14" (top), 18" (middle) and 21" (bottom) rockhopper disks.*

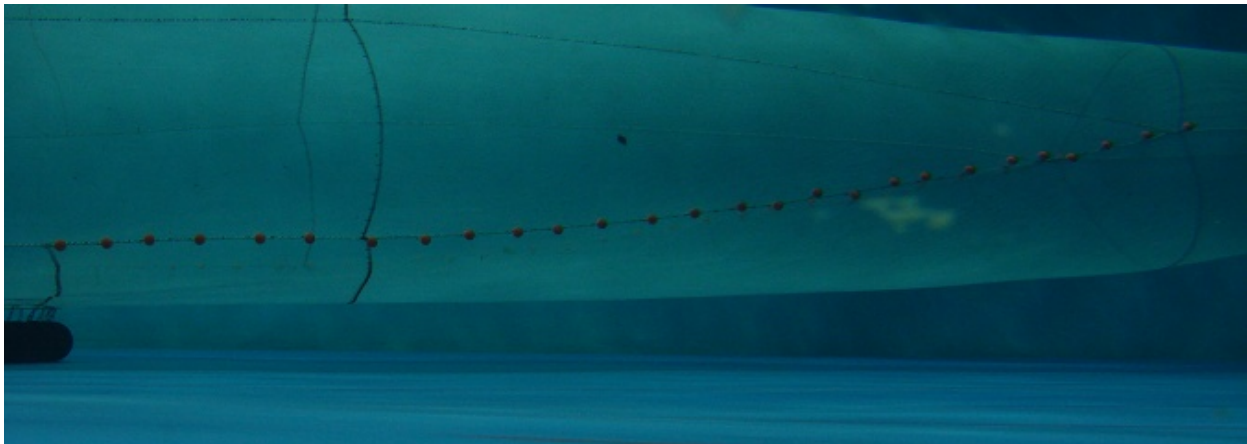

*Figure 2. Model float line (Rig 24) along the lower belly seam.*

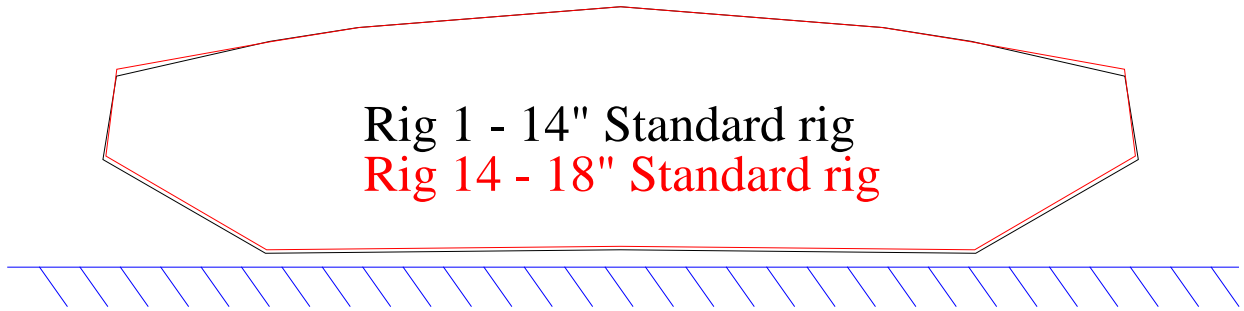

Figure 3. Mouth Area – Rig 1 (black) versus Rig 14 (red).



Figure 4. Mouth Area – Rig 1 (black) versus Rig 33 (red).

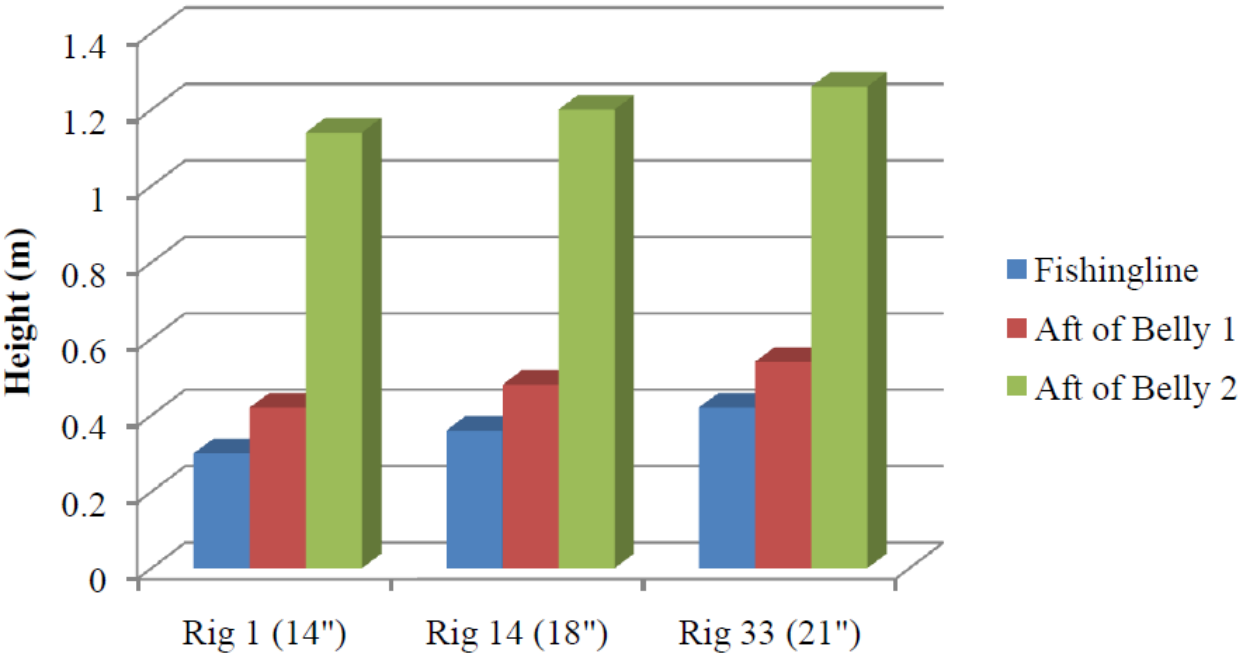

Figure 5. Effect of rockhopper size on fishingline and belly geometry.

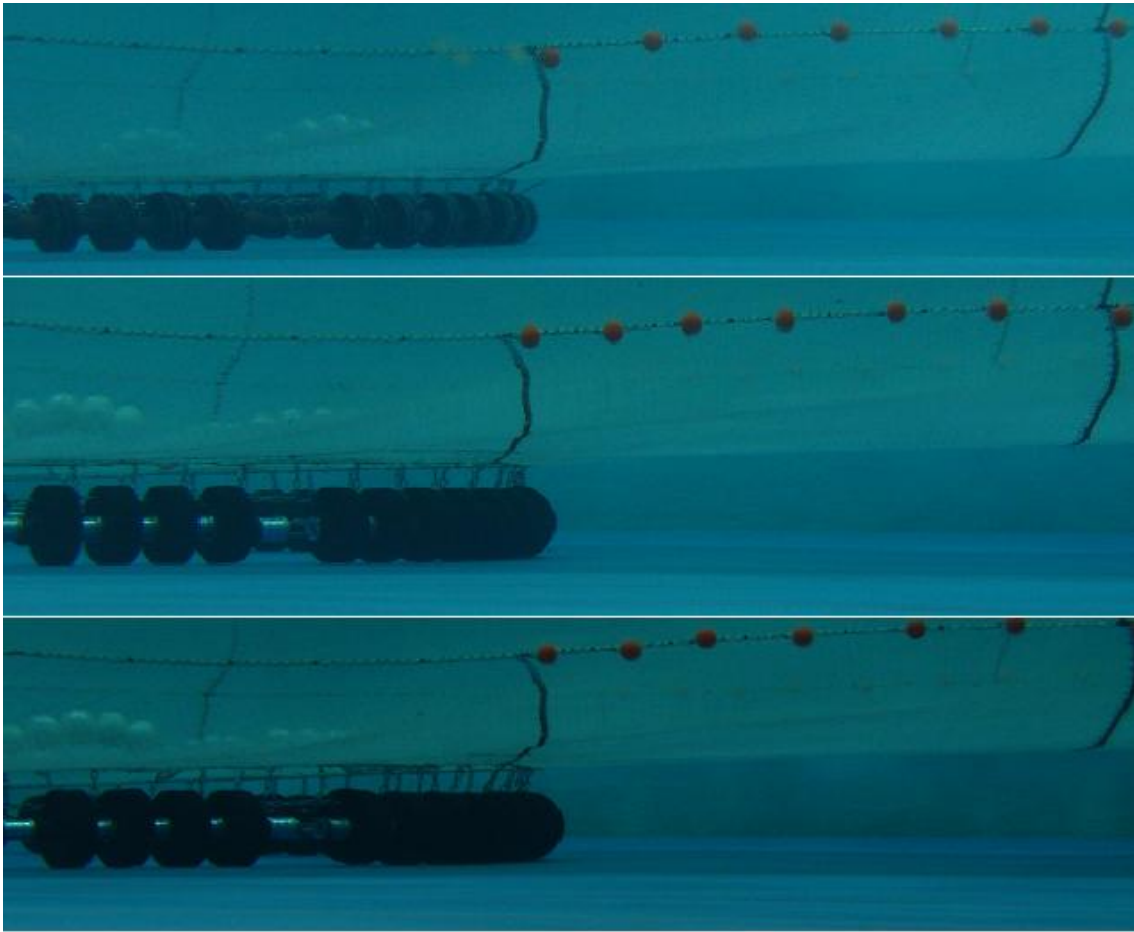

Figure 6. Fishingline clearance for Rigs 12, 21 and 24 (top to bottom respectively).

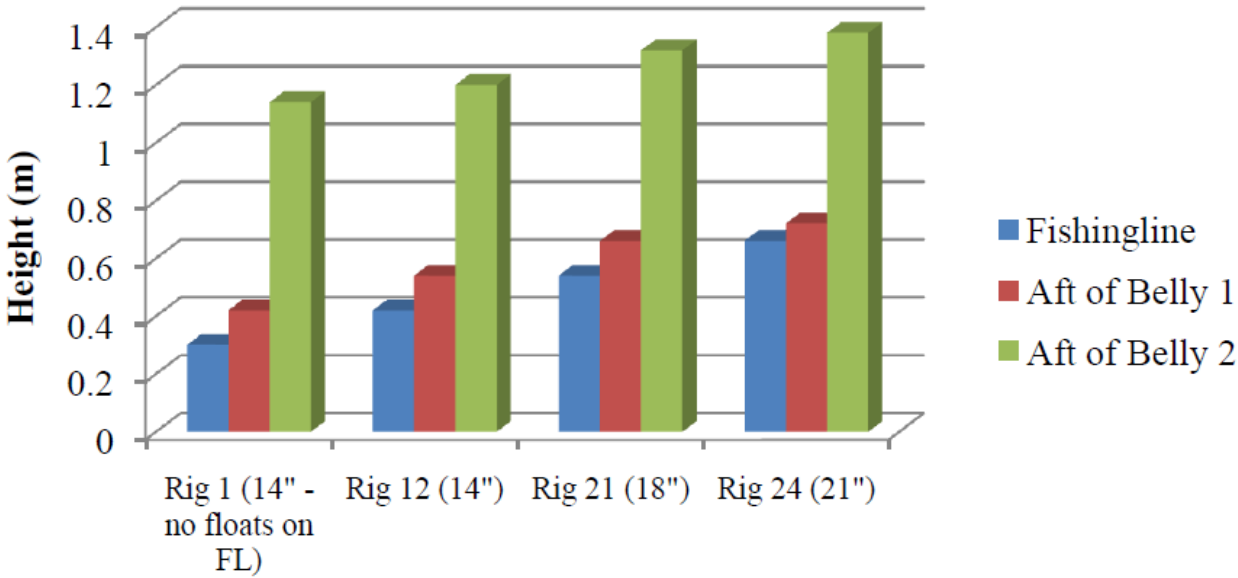

Figure 7. Effect of fishingline floats on fishingline/belly clearance.

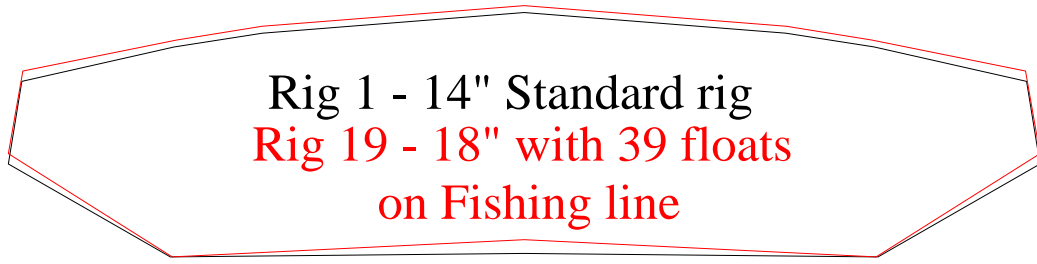

Figure 8. Mouth Area – Rig 1 (black) versus Rig 19 (red).

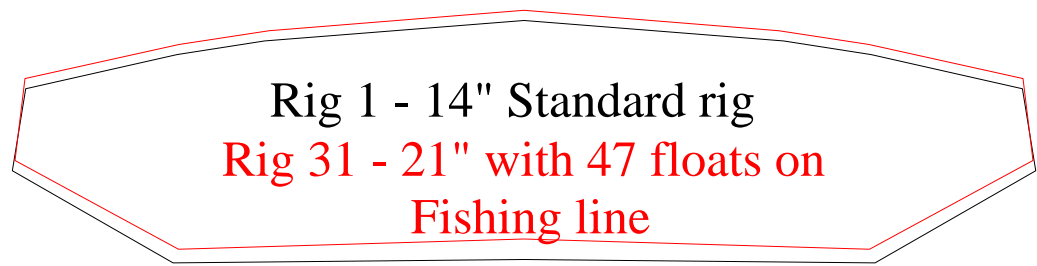
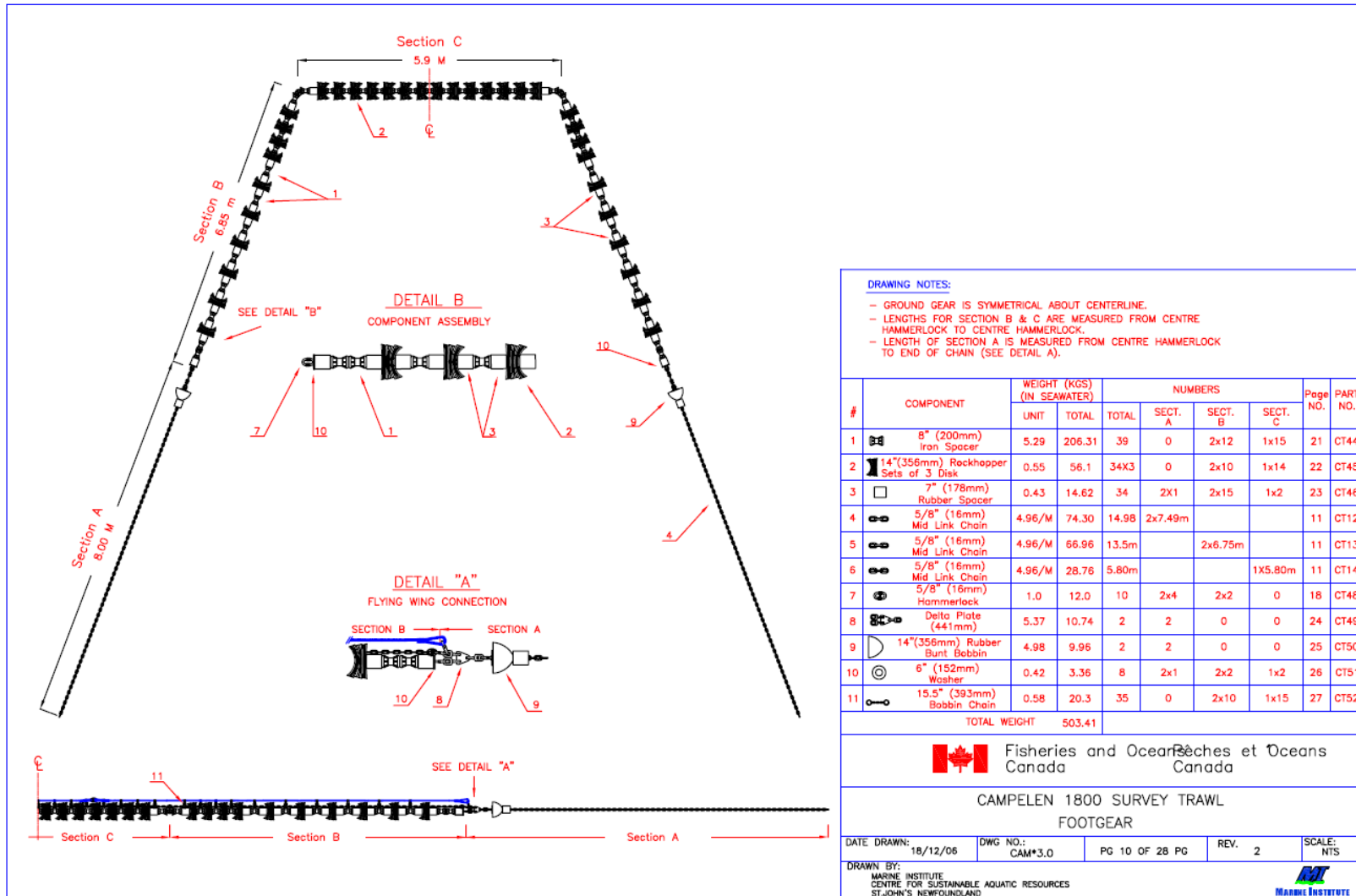

Figure 9. Mouth Area – Rig 1 (black) versus Rig 31 (red).



## APPENDIX A. SPECIFICATIONS OF THE FOOTGEAR OF THE STANDARD 1800 CAMPELEN TRAWL.



Appendix A Figure 1. Specifications of the footgear of the standard 1800 Campelen trawl. The specifications of the entire trawl can be found in Walsh et al. (2009).

## APPENDIX B. TRAWL GEOMETRY

Trawl Geometry data sheets from the flume tank trials of the modifications to the Northern Shrimp Research Foundation Campelen 1800 trawl. Full Scale Values (Metric Units). Mouth area is represented as the product of mean wing end spread and headline opening.

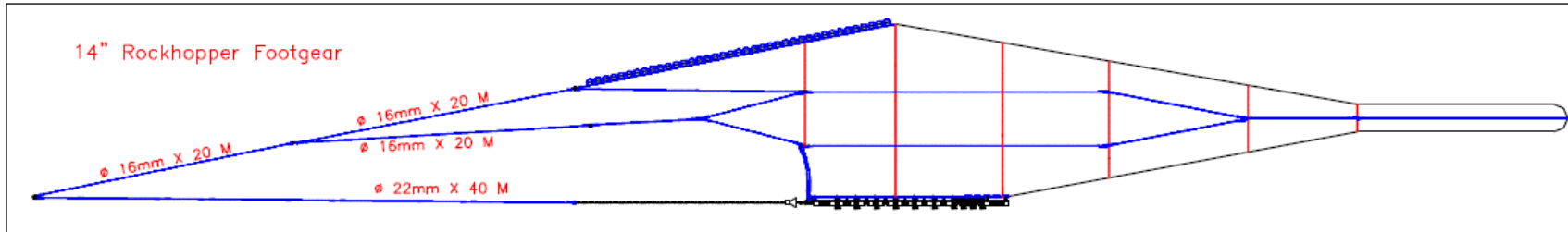

Appendix B Figure 1. Rig 1 Standard Rig

Appendix B Table 1. Trawl geometry data from the flume tank trials of the modifications to the Northern Shrimp Research Foundation Campelen 1800 trawl—Rig 1 Standard Rig.

Door type	U. bridle length (m)	L. bridle length (m)	1 float bouy (kgf)	Float no. Headline	Float no. f/line	Total Bouy. (kgf)															
N/A	40.00	40.00	2.55	90	0	229.5	SPREAD				OPENING			BELLY HEIGHT		TENSION			Mouth area (m <sup>2</sup> )	Mouth drag (kgf/m <sup>2</sup> )	Bridle angle (deg.)
Towing speed (kts)	Door (m)	U. wing (m)	L. wing (m)	Mean w/e (m)	M. wing (m)	Wing (m)	Headline (m)	HL fr. Bottom (m)	F/line in bosum	Aft of 1st belly	Aft of 2nd belly	Port (tonnes)	Stbd (tonnes)	Total (tonnes)							
2.75	51.24	17.47	18.07	17.77	20.50	3.36	4.44	4.74	0.30	0.42	1.20	2.45	2.49	4.94	78.9	62.6	21.3				
3.00	51.23	17.63	18.12	17.87	20.52	3.06	4.20	4.50	0.30	0.42	1.14	2.83	2.82	5.65	75.1	75.3	21.2				
3.25	51.23	17.61	18.06	17.84	20.59	2.88	3.84	4.14	0.30	0.42	1.08	3.19	3.20	6.40	68.5	93.4	21.2				
3.50	51.26	17.51	17.81	17.66	20.63	2.76	3.72	4.02	0.30	0.42	1.02	3.53	3.48	7.00	65.7	106.6	21.4				
3.75	51.25	17.53	17.87	17.70	20.53	2.58	3.60	3.90	0.30	0.42	1.02	3.74	3.75	7.48	63.7	117.4	21.3				

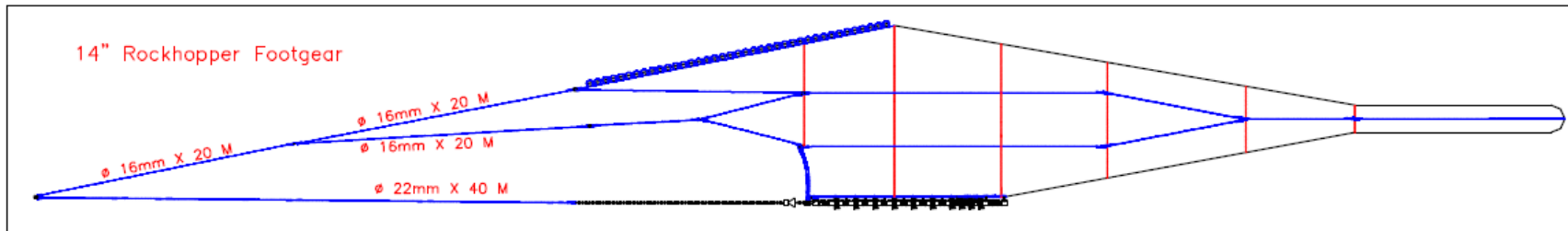

Appendix B Figure 2. Rig 1–5 Standard Rig (with reduced door spread @3kt).

Appendix B Table 2. Trawl geometry data from the flume tank trials of the modifications to the Northern Shrimp Research Foundation Campelen 1800 trawl–Rig 1–5 Standard Rig (with reduced door spread @3kt).

Door type	U. bridle length (m)	L. bridle length (m)	1 float bouy (kgf)	Float no. Headline	Float no. f/line	Total Bouy. (kgf)											
Towing speed (kts)	SPREAD					OPENING				BELLY HEIGHT		TENSION			Mouth area (m <sup>2</sup> )	Mouth drag (kgf/m <sup>2</sup> )	Bridle angle (deg.)
	Door (m)	U. wing (m)	L. wing (m)	Mean w/e (m)	M. wing (m)	Wing (m)	Headline (m)	HL fr. Bottom (m)	F/line in bosum	Aft of 1st belly	Aft of 2nd belly	Port (tonnes)	Stbd (tonnes)	Total (tonnes)			
Rig 1	51.23	17.63	18.12	17.87	20.52	3.06	4.20	4.50	0.30	0.42	1.14	2.83	2.82	5.65	75.1	75.3	21.2
Rig 2	49.23	17.26	17.50	17.38	19.97	3.00	4.14	4.44	0.30	0.42	1.14	2.86	2.86	5.72	72.0	79.5	20.2
Rig 3	47.23	16.83	16.93	16.88	19.41	3.06	4.20	4.50	0.30	0.42	1.14	2.89	2.88	5.77	70.9	81.4	19.2
Rig 4	44.21	16.26	16.24	16.25	18.63	3.12	4.50	4.80	0.30	0.42	1.20	2.88	2.88	5.77	73.1	78.9	17.6
Rig 5	40.54	15.50	15.22	15.36	17.68	3.36	4.74	5.04	0.30	0.42	1.26	2.88	2.85	5.74	72.8	78.8	15.8

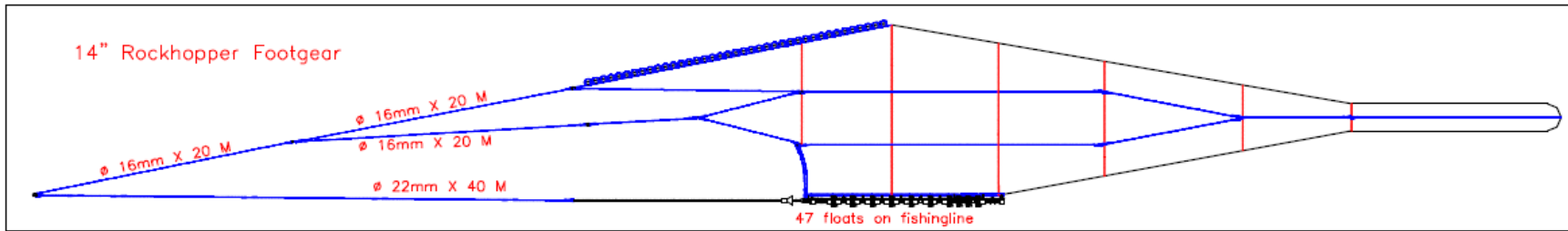

Appendix B Figure 3. Rig 8 - 47 floats on fishingline.

Appendix B Table 3. Trawl geometry data from the flume tank trials of the modifications to the Northern Shrimp Research Foundation Campelen 1800 trawl–Rig 8 - 47 floats on fishingline.

Door type	U. bridle length (m)	L. bridle length (m)	1 float bouy (kgf)	Float no. Headline	Float no. f/line	Total Bouy. (kgf)	SPREAD				BELL Y HEIGHT		TENSION			Mouth area (m <sup>2</sup> )	Mouth drag (kgf/m <sup>2</sup> )	Bridle angle (deg.)		
N/A	40.00	40.00	2.55	90	47	349.4	Door (m)	U. wing (m)	L. wing (m)	Mean w/e (m)	M. wing (m)	Wing (m)	Headline (m)	HL fr. Bottom (m)	F/line in bosum				Aft of 1st belly	Aft of 2nd belly
3.00	51.24	17.62	17.98	17.80	20.59	3.12	4.14	4.56	0.42	0.54	1.38	2.78	2.80	5.57	73.7	75.7	21.3			
3.75	51.24	17.57	17.99	17.78	20.59	2.70	3.54	3.96	0.42	0.54	1.14	3.77	3.77	7.53	62.9	119.7	21.3			

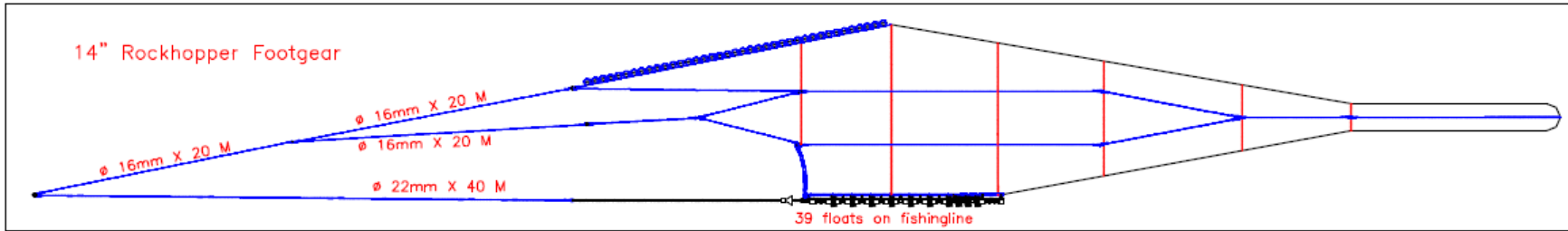

Appendix B Figure 4 Rig 9 - 39 floats on Fishingline, none in bosum.

Appendix B Table 4. Trawl geometry data from the flume tank trials of the modifications to the Northern Shrimp Research Foundation Campelen 1800 trawl—Rig 9 - 39 floats on Fishingline, none in bosum.

Door type	U. bridle length (m)	L. bridle length (m)	1 float bouy (kgf)	Float no. Headline	Float no. f/line	Total Bouy. (kgf)											
Towing speed (kts)	SPREAD					OPENING				BELLY HEIGHT		TENSION			Mouth area (m <sup>2</sup> )	Mouth drag (kgf/m <sup>2</sup> )	Bridle angle (deg.)
	Door (m)	U. wing (m)	L. wing (m)	Mean w/e (m)	M. wing (m)	Wing (m)	Headline (m)	HL fr. Bottom (m)	F/line in bosum	Aft of 1st belly	Aft of 2nd belly	Port (tonnes)	Stbd (tonnes)	Total (tonnes)			
N/A	40.00	40.00	2.55	90	39	329.0											
3.00	51.25	17.54	17.90	17.72	20.45	3.12	4.20	4.56	0.36	0.54	1.26	2.80	2.83	5.63	74.4	75.6	21.3

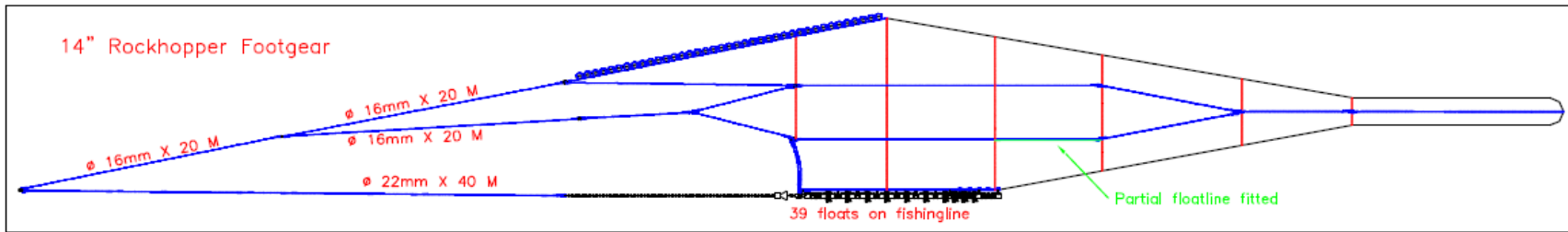

Appendix B Figure 5. Rig 12 - 39 floats on Fishingline (floatline on lower ribline).

Appendix B Table 5. Trawl geometry data from the flume tank trials of the modifications to the Northern Shrimp Research Foundation Campelen 1800 trawl—Rig 12 - 39 floats on Fishingline (floatline on lower ribline).

Door type	U. bridle length (m)	L. bridle length (m)	1 float bouy (kgf)	Float no. Headline	Float no. f/line	Total Bouy. (kgf)												
Towing speed (kts)	SPREAD					OPENING				BELLY HEIGHT		TENSION			Mouth area (m <sup>2</sup> )	Mouth drag (kgf/m <sup>2</sup> )	Bridle angle (deg.)	
	Door (m)	U. wing (m)	L. wing (m)	Mean w/e (m)	M. wing (m)	Wing (m)	Headline (m)	HL fr. Bottom (m)	F/line in bosum	Aft of 1st belly	Aft of 2nd belly	Port (tonnes)	Stbd (tonnes)	Total (tonnes)				
N/A	40.00	40.00	2.55	90	39	329.0												
3.00	51.25	17.45	17.96	17.71	20.50	3.12	4.20	4.62	0.42	0.54	1.20	2.76	2.78	5.54	74.4	74.5	21.3	

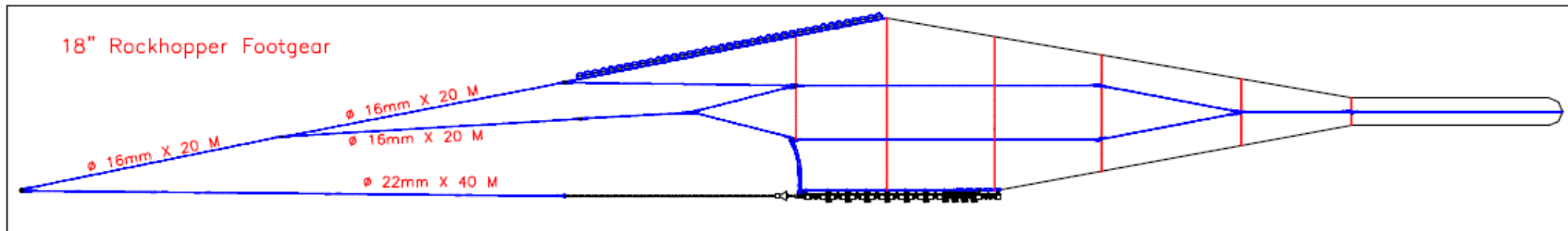

Appendix B Figure 6. Rig 14 - 18" footgear.

Appendix B Table 6. Trawl geometry data from the flume tank trials of the modifications to the Northern Shrimp Research Foundation Campelen 1800 trawl—Rig 14 - 18" footgear.

Door type	U. bridle length (m)	L. bridle length (m)	1 float bouy (kgf)	Float no. Headline	Float no. f/line	Total Bouy. (kgf)											
Towing speed (kts)	SPREAD					OPENING				BELLY HEIGHT		TENSION			Mouth area (m <sup>2</sup> )	Mouth drag (kgf/m <sup>2</sup> )	Bridle angle (deg.)
	Door (m)	U. wing (m)	L. wing (m)	Mean w/e (m)	M. wing (m)	Wing (m)	Headline (m)	HL fr. Bottom (m)	F/line in bosum	Aft of 1st belly	Aft of 2nd belly	Port (tonnes)	Stbd (tonnes)	Total (tonnes)			
N/A	40.00	40.00	2.55	90	0	229.5											
2.75	51.26	17.46	17.90	17.68	20.39	3.36	4.44	4.80	0.36	0.48	1.26	2.43	2.47	4.90	78.5	62.4	21.3
3.00	51.25	17.50	17.93	17.72	20.48	3.18	4.14	4.50	0.36	0.48	1.20	2.78	2.83	5.60	73.3	76.4	21.3
3.75	51.25	17.58	17.89	17.74	20.60	2.70	3.54	4.02	0.48	0.54	1.08	3.76	3.72	7.48	62.8	119.2	21.3

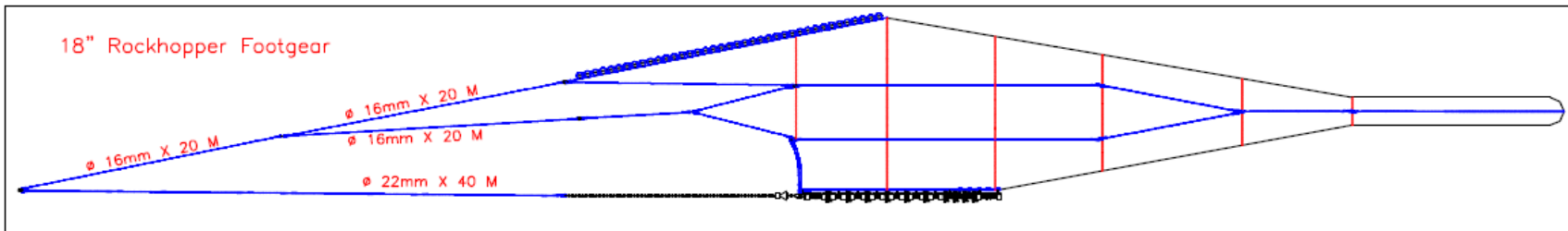

Appendix B Figure 7. Rig 15 - 18" footgear (reduced door spread).

Appendix B Table 7. Trawl geometry data from the flume tank trials of the modifications to the Northern Shrimp Research Foundation Campelen 1800 trawl—Rig 15 - 18" footgear (reduced door spread).

Door type	U. bridle length (m)	L. bridle length (m)	1 float bouy (kgf)	Float no. Headline	Float no. f/line	Total Bouy. (kgf)												
Towing speed (kts)	SPREAD					OPENING				BELLY HEIGHT		TENSION			Mouth area (m <sup>2</sup> )	Mouth drag (kgf/m <sup>2</sup> )	Bridle angle (deg.)	
	Door (m)	U. wing (m)	L. wing (m)	Mean w/e (m)	M. wing (m)	Wing (m)	Headline (m)	HL fr. Bottom (m)	F/line in bosum	Aft of 1st belly	Aft of 2nd belly	Port (tonnes)	Stbd (tonnes)	Total (tonnes)				
N/A	40.00	40.00	2.55	90	0	229.5												
3.00	40.55	15.47	15.20	15.34	17.57	3.42	4.80	5.16	0.36	0.42	1.32	2.77	2.79	5.57	73.6	75.6	15.9	



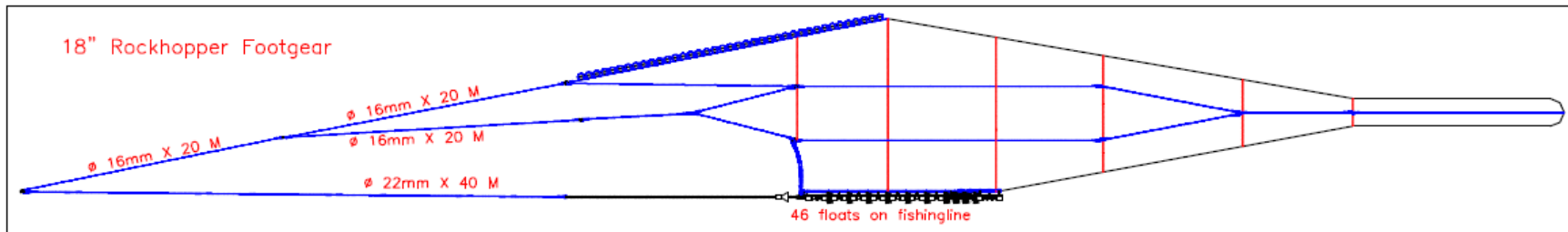

Appendix B Figure 8. Rig 17 - 18" footgear (46 extra floats on fishingline).

Appendix B Table 8. Trawl geometry data from the flume tank trials of the modifications to the Northern Shrimp Research Foundation Campelen 1800 trawl–Rig 17 - 18" footgear (46 extra floats on fishingline).

Door type	U. bridle length (m)	L. bridle length (m)	1 float bouy (kgf)	Float no. Headline	Float no. f/line	Total Bouy. (kgf)														
N/A	40.00	40.00	2.55	90	46	346.8	SPREAD			OPENING			BELLY HEIGHT		TENSION			Mouth area (m <sup>2</sup> )	Mouth drag (kgf/m <sup>2</sup> )	Bridle angle (deg.)
Towing speed (kts)	Door (m)	U. wing (m)	L. wing (m)	Mean w/e (m)	M. wing (m)	Wing (m)	Headline (m)	HL fr. Bottom (m)	F/line in bosum	Aft of 1st belly	Aft of 2nd belly	Port (tonnes)	Stbd (tonnes)	Total (tonnes)						
3.00	51.3	17.5	17.8	17.7	20.5	3.1	4.08	4.62	0.54	0.72	1.32	2.8	2.8	5.58	72.1	77.4	21.3			
3.75	51.3	17.5	17.9	17.7	20.6	2.8	3.5	4.1	0.54	0.66	1.14	3.7	3.8	7.5	62.7	119.9	21.3			

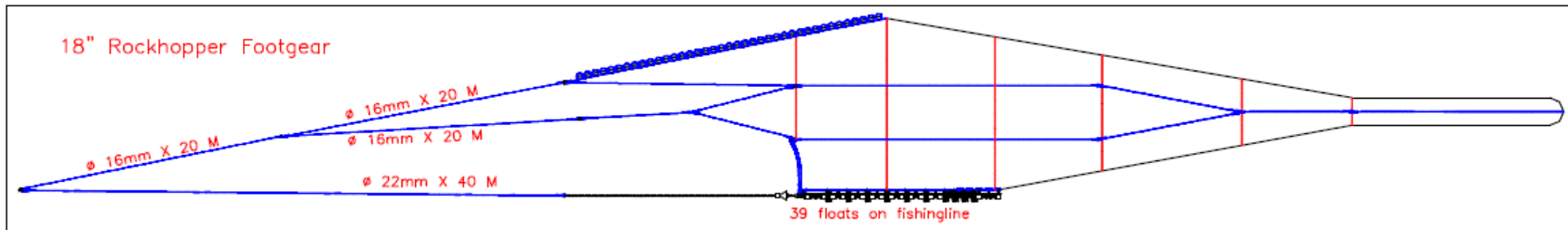

Appendix B Figure 9. Rig 19 - 18" footgear (39 extra floats on fishingline with none in bosum).

Appendix B Table 9. Trawl geometry data from the flume tank trials of the modifications to the Northern Shrimp Research Foundation Campelen 1800 trawl—Rig 19 - 18" footgear (39 extra floats on fishingline with none in bosum).

Door type	U. bridle length (m)	L. bridle length (m)	1 float bouy (kgf)	Float no. Headline	Float no. f/line	Total Bouy. (kgf)																
N/A	40.00	40.00	2.55	90	39	329.0	SPREAD				OPENING				BELLY HEIGHT		TENSION			Mouth area (m <sup>2</sup> )	Mouth drag (kgf/m <sup>2</sup> )	Bridle angle (deg.)
Towing speed (kts)	Door (m)	U. wing (m)	L. wing (m)	Mean w/e (m)	M. wing (m)	Wing (m)	Headline (m)	HL fr. Bottom (m)	F/line in bosum	Aft of 1st belly	Aft of 2nd belly	Port (tonnes)	Stbd (tonnes)	Total (tonnes)								
3.00	51.26	17.44	17.93	17.68	20.45	3.18	4.08	4.62	0.54	0.66	1.32	2.77	2.79	5.56	72.1	77.1	21.3					
3.75	51.25	17.49	17.90	17.70	20.52	2.76	3.54	4.08	0.54	0.66	1.20	3.78	3.74	7.52	62.6	120.0	21.3					

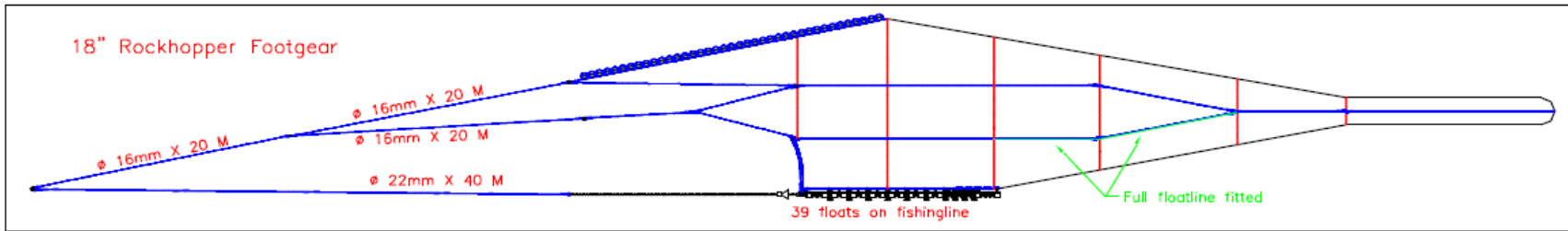

Appendix B Figure 10. Rig 21 - 18" footgear (39 extra floats on fishingline with none in bosum).

Appendix B Table 10. Trawl geometry data from the flume tank trials of the modifications to the Northern Shrimp Research Foundation Campelen 1800 trawl—Rig 21 - 18" footgear (39 extra floats on fishingline with none in bosum).

Door type	U. bridle length (m)	L. bridle length (m)	1 float bouy (kgf)	Float no. Headline	Float no. f/line	Total Bouy. (kgf)	SPREAD				OPENING			BELLY HEIGHT		TENSION			Mouth area (m <sup>2</sup> )	Mouth drag (kgf/m <sup>2</sup> )	Bridle angle (deg.)			
							Door (m)	U. wing (m)	L. wing (m)	Mean w/e (m)	M. wing (m)	Wing (m)	Headline (m)	HL fr. Bottom (m)	F/line in bosum	Aft of 1st belly	Aft of 2nd belly	Port (tonnes)				Stbd (tonnes)	Total (tonnes)	
N/A	40.00	40.00	2.55	90	39	329.0																		
3.00	51.26	17.46	17.90	17.68	20.44	3.18	4.08	4.62	0.54	0.66	1.32	2.76	2.79	5.55	72.1	76.9	21.3							
3.75	51.26	17.48	17.87	17.68	20.54	2.76	3.54	4.08	0.54	0.66	1.14	3.76	3.75	7.51	62.6	120.0	21.3							

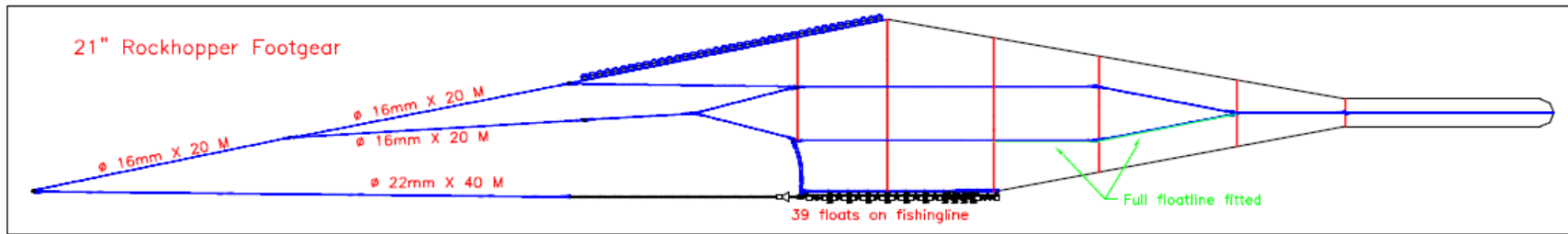

Appendix B Figure 11. Rig 24 - 21" footgear (39 extra floats on fishingline with none in bosum, full floatline on lower ribline, delta plate 1.5 x larger).

Appendix B Table 11. Trawl geometry data from the flume tank trials of the modifications to the Northern Shrimp Research Foundation Campelen 1800 trawl—Rig 24 - 21" footgear (39 extra floats on fishingline with none in bosum, full floatline on lower ribline, delta plate 1.5 x larger).

Door type	U. bridle length (m)	L. bridle length (m)	1 float bouy (kgf)	Float no. Headline	Float no. f/line	Total Bouy. (kgf)	SPREAD				OPENING			BELLY HEIGHT		TENSION			Mouth area (m <sup>2</sup> )	Mouth drag (kgf/m <sup>2</sup> )	Bridle angle (deg.)			
							Door (m)	U. wing (m)	L. wing (m)	Mean w/e (m)	M. wing (m)	Wing (m)	Headline (m)	HL fr. Bottom (m)	F/line in bosum	Aft of 1st belly	Aft of 2nd belly	Port (tonnes)				Stbd (tonnes)	Total (tonnes)	
N/A	40.00	40.00	2.55	90	39	329.0																		
3.00	51.25	17.59	17.81	17.70	20.42	3.18	3.96	4.62	0.66	0.72	1.38	2.88	2.90	5.78	70.1	82.5	21.30							
3.75	51.27	17.45	17.78	17.62	20.48	2.76	3.42	4.08	0.66	0.72	1.26	3.81	3.80	7.61	60.2	126.3	21.40							

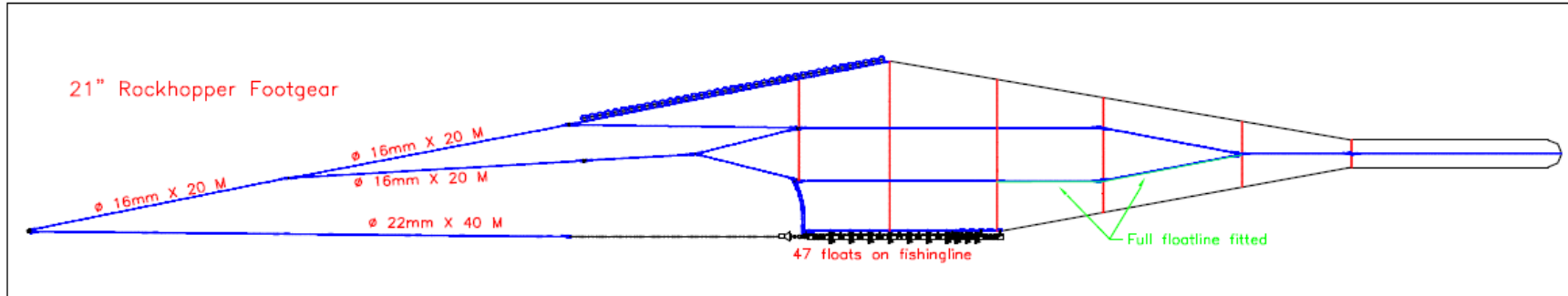

Appendix B Figure 12. Rig 26 - 21" footgear (47 extra floats on fishingline with none in bosum, full floatline on lower ribline).

Appendix B Table 12. Trawl geometry data from the flume tank trials of the modifications to the Northern Shrimp Research Foundation Campelen 1800 trawl—Rig 26 - 21" footgear (47 extra floats on fishingline with none in bosum, full floatline on lower ribline).

Door type	U. bridle length (m)	L. bridle length (m)	1 float bouy (kgf)	Float no. Headline	Float no. f/line	Total Bouy. (kgf)	SPREAD				OPENING			BELLY HEIGHT		TENSION			Mouth area (m <sup>2</sup> )	Mouth drag (kgf/m <sup>2</sup> )	Bridle angle (deg.)		
							Door (m)	U. wing (m)	L. wing (m)	Mean w/e (m)	M. wing (m)	Wing (m)	Headline (m)	HL fr. Bottom (m)	F/line in bosum	Aft of 1st belly	Aft of 2nd belly	Port (tonnes)				Stbd (tonnes)	Total (tonnes)
N/A	40.00	40.00	2.55	90	47	349.4																	
3.00	51.24	17.61	17.89	17.75	20.59	3.24	4.02	4.68	0.66	0.78	1.38	2.86	2.91	5.77	71.3	80.9	21.3						
3.75	51.24	17.56	17.99	17.77	20.72	2.82	3.54	4.20	0.66	0.72	1.26	3.82	3.85	7.67	62.9	122.0	21.3						

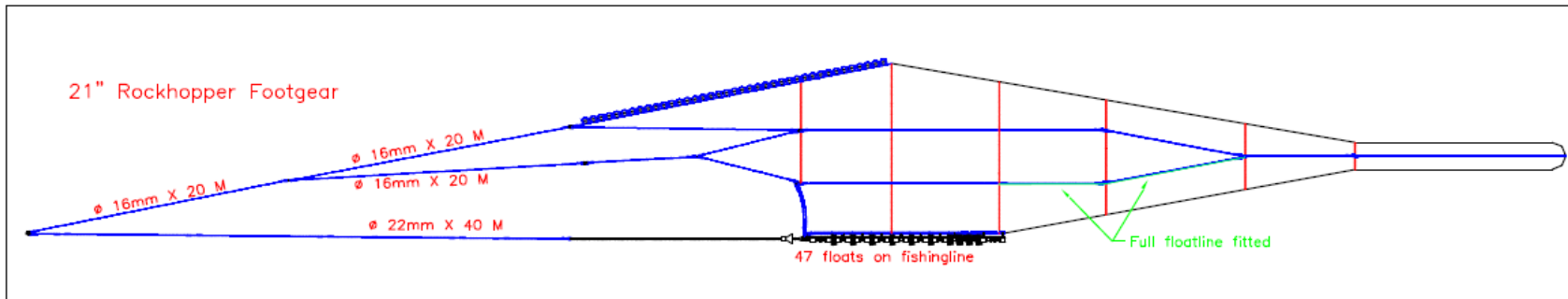

Appendix B Figure 13. Rig 27 - Same as Rig 26 but reduced door spread.

Appendix B Table 13. Trawl geometry data from the flume tank trials of the modifications to the Northern Shrimp Research Foundation Campelen 1800 trawl-Rig 27 - Same as Rig 26 but reduced door spread.

Door type	U. bridle length (m)	L. bridle length (m)	1 float bouy (kgf)	Float no. Headline	Float no. f/line	Total Bouy. (kgf)											
Towing speed (kts)	SPREAD					OPENING				BELLY HEIGHT		TENSION			Mouth area (m <sup>2</sup> )	Mouth drag (kgf/m <sup>2</sup> )	Bridle angle (deg.)
	Door (m)	U. wing (m)	L. wing (m)	Mean w/e (m)	M. wing (m)	Wing (m)	Headline (m)	HL fr. Bottom (m)	F/line in bosum	Aft of 1st belly	Aft of 2nd belly	Port (tonnes)	Stbd (tonnes)	Total (tonnes)			
N/A	40.00	40.00	2.55	90	47	349.4											
2.75	47.23	16.84	16.93	16.88	19.41	3.48	4.50	5.16	0.66	0.78	1.56	2.52	2.62	5.14	76.0	67.7	19.2
3.00	47.22	16.88	16.92	16.90	19.44	3.30	4.20	4.86	0.66	0.78	1.44	2.90	2.97	5.86	71.0	82.6	19.2
3.75	47.24	16.78	16.83	16.81	19.52	2.88	3.66	4.32	0.66	0.78	1.26	3.86	3.88	7.74	61.5	125.8	19.3

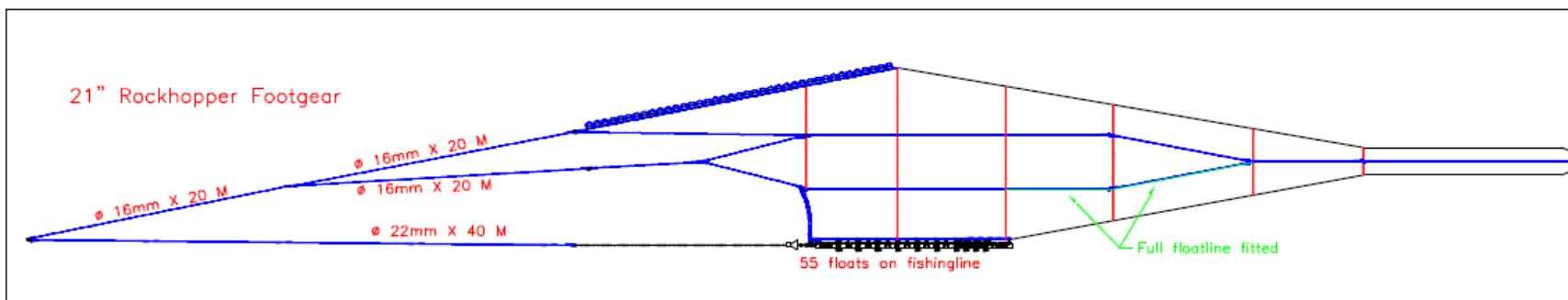

Appendix B Figure 14. Rig 29 - 21" footgear - 55 extra floats on floatline with non in bosum, full floatline on lower ribline.

Appendix B Table 14. Trawl geometry data from the flume tank trials of the modifications to the Northern Shrimp Research Foundation Campelen 1800 trawl—Rig 29 - 21" footgear - 55 extra floats on floatline with non in bosum, full floatline on lower ribline.

Door type	U. bridle length (m)	L. bridle length (m)	1 float bouy (kgf)	Float no. Headline	Float no. f/line	Total Bouy. (kgf)													
N/A	40.00	40.00	2.55	90	55	369.8	SPREAD			OPENING		BELLY HEIGHT		TENSION			Mouth area (m <sup>2</sup> )	Mouth drag (kgf/m <sup>2</sup> )	Bridle angle (deg.)
Towing speed (kts)	Door (m)	U. wing (m)	L. wing (m)	Mean w/e (m)	M. wing (m)	Wing (m)	Headline (m)	HL fr. Bottom (m)	F/line in bosum	Aft of 1st belly	Aft of 2nd belly	Port (tonnes)	Stbd (tonnes)	Total (tonnes)					
3.00	51.26	17.50	17.83	17.66	20.43	3.18	4.02	4.68	0.66	0.78	1.44	2.88	2.87	5.75	71.0	81.0	21.4		
3.75	51.25	17.50	17.89	17.69	21.51	2.82	3.48	4.20	0.72	0.78	1.20	3.87	3.82	7.69	61.6	124.9	21.3		

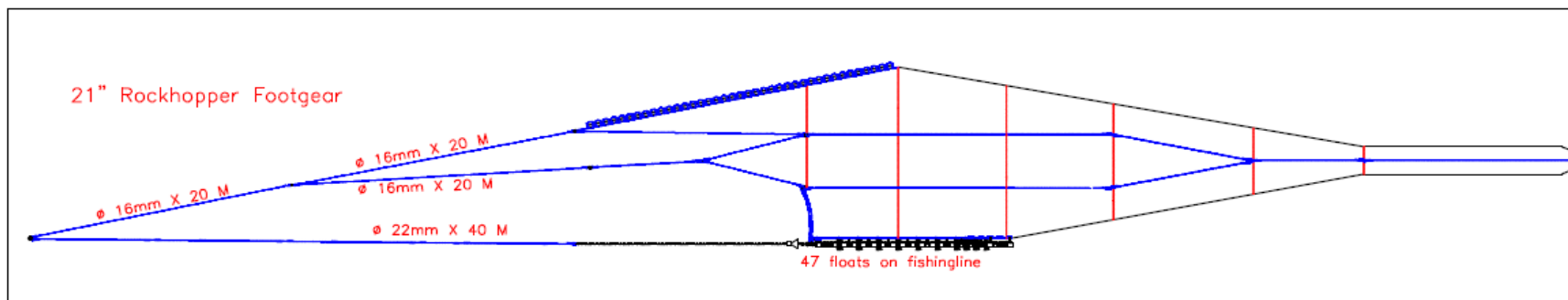

Appendix B Figure 15. Rig 31 - 21" footgear - 47 extra floats on floatline with none in bosum, floatline removed.

Appendix B Table 15. Trawl geometry data from the flume tank trials of the modifications to the Northern Shrimp Research Foundation Campelen 1800 trawl—Rig 31 - 21" footgear - 47 extra floats on floatline with none in bosum, floatline removed.

Door type	U. bridle length (m)	L. bridle length (m)	1 float bouy (kgf)	Float no. Headline	Float no. f/line	Total Bouy. (kgf)											
Towing speed (kts)	SPREAD					OPENING				BELLY HEIGHT		TENSION			Mouth area (m <sup>2</sup> )	Mouth drag (kgf/m <sup>2</sup> )	Bridle angle (deg.)
	Door (m)	U. wing (m)	L. wing (m)	Mean w/e (m)	M. wing (m)	Wing (m)	Headline (m)	HL fr. Bottom (m)	F/line in bosum	Aft of 1st belly	Aft of 2nd belly	Port (tonnes)	Stbd (tonnes)	Total (tonnes)			
N/A	40.00	40.00	2.55	90	47	349.4											
3.00	51.25	17.50	17.90	17.70	20.55	3.18	4.02	4.68	0.66	0.78	1.38	2.83	2.86	5.68	71.2	79.9	21.3
3.75	51.25	17.52	17.86	17.69	20.61	2.76	3.48	4.14	0.66	0.78	1.26	3.82	3.78	7.60	61.6	123.4	21.3



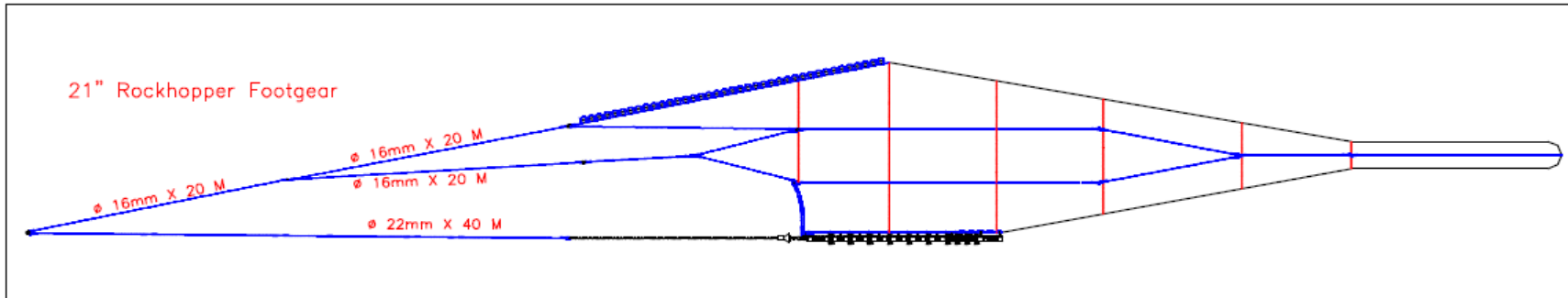

Appendix B Figure 16. Rig 33 - 21" footgear - no fishingline floats.

Appendix B Table 16. Trawl geometry data from the flume tank trials of the modifications to the Northern Shrimp Research Foundation Campelen 1800 trawl—Rig 33 - 21" footgear - no fishingline floats.

Door type	U. bridle length (m)	L. bridle length (m)	1 float bouy (kgf)	Float no. Headline	Float no. f/line	Total Bouy. (kgf)									Mouth area (m <sup>2</sup> )	Mouth drag (kgf/m <sup>2</sup> )	Bridle angle (deg.)
Towing speed (kts)	SPREAD					OPENING				BELLY HEIGHT		TENSION					
	Door (m)	U. wing (m)	L. wing (m)	Mean w/e (m)	M. wing (m)	Wing (m)	Headline (m)	HL fr. Bottom (m)	F/line in bosum	Aft of 1st belly	Aft of 2nd belly	Port (tonnes)	Stbd (tonnes)	Total (tonnes)			
N/A	40.00	40.00	2.55	90	0	229.5											
3.00	51.24	17.58	18.03	17.81	20.62	3.06	4.20	4.62	0.42	0.54	1.26	2.86	2.87	5.73	74.8	76.6	21.2
3.75	51.25	17.59	17.90	17.74	20.63	2.76	3.48	3.96	0.48	0.54	1.08	3.74	3.75	7.49	61.7	121.3	21.3

Rig 34 - Same as Rig 33 but reduced door spread.

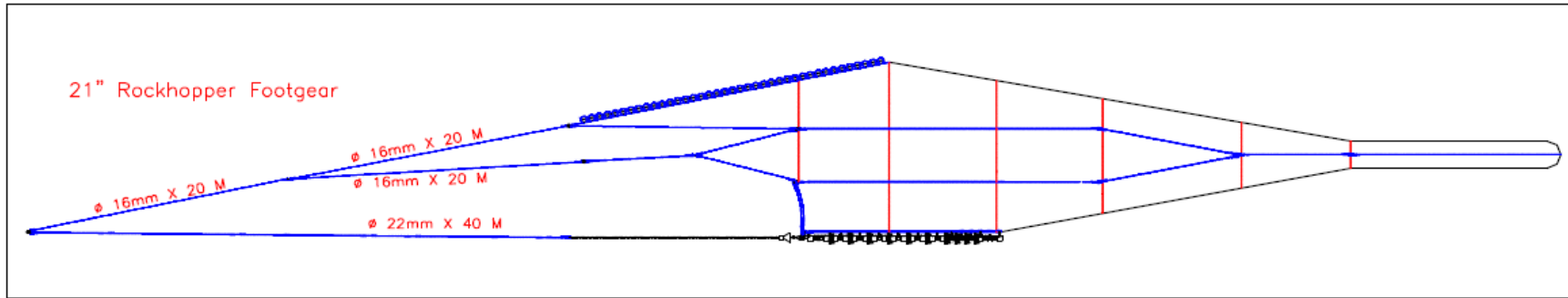

Appendix B Figure 17. Rig 34 - Same as Rig 33 but reduced door spread.

Appendix B Table 17. Trawl geometry data from the flume tank trials of the modifications to the Northern Shrimp Research Foundation Campelen 1800 trawl—Rig 34 - Same as Rig 33 but reduced door spread.

Door type	U. bridle length (m)	L. bridle length (m)	1 float bouy (kgf)	Float no. Headline	Float no. f/line	Total Bouy. (kgf)											Mouth area (m <sup>2</sup> )	Mouth drag (kgf/m <sup>2</sup> )	Bridle angle (deg.)
SPREAD						OPENING				BELLY HEIGHT		TENSION							
Towing speed (kts)	Door (m)	U. wing (m)	L. wing (m)	Mean w/e (m)	M. wing (m)	Wing (m)	Headline (m)	HL fr. Bottom (m)	F/line in bosum	Aft of 1st belly	Aft of 2nd belly	Port (tonnes)	Stbd (tonnes)	Total (tonnes)					
N/A	40.00	40.00	2.55	90	0	229.5													
3.00	40.54	15.49	15.28	15.39	17.68	3.36	4.80	5.28	0.48	0.54	1.38	2.85	2.80	5.65	73.9	76.5	15.8		

---

## APPENDIX C. MODIFIED CAMPELEN TRAWL DETAILED DRAWINGS AND SPECIFICATIONS.

Detailed drawings and specifications of the modifications made to the Campelen trawl and now used full scale for NSRF-DFO surveys in RISA and SFA2EX.

Parts required for standard bobbin chain:

- One quick link per bobbin chain; 35 of Blue Line Part # DQ 08 SS OL (or equivalent)
- 5 links of 5/16" chain with a pitch of 35 mm; 35 pieces (same chain as used with part CT-52)
- 3/8" steel rings (ID = 76 mm (3")), 70 pieces

Parts required for modified bobbin chain (21" footgear). Utilizes the standard bobbin chain with additional:

- 3/8" steel rings (ID = 76 mm (3")); 35 pieces MOUNTED ON 21" FOOTGEAR

Modified delta plate (2 required):

- Blue Line E4-250 or equivalent (note-remove 3<sup>rd</sup> swivel from this delta plate as per drawing)
- Adjust length of flying wing chain so that wing section "A" remains 8.0 m

21" Rockhopper (34 sets of 3):

- Availability of thickness similar to 14" rockhopper may dictate minor modifications (i.e. reduce number of rockhoppers in rockhopper set, or make other minor adjustments to allow footgear construction to be similar to that of the standard 14" footgear).

21" Bunt bobbin (2 required):

- As flume tank tested, weight in water = 14.7 kg, diameter = 535 mm (21")

Typically:

- Morernot AS – article # 25020013 (13 kg in water)
- AMS – AMS reference BOBBUNTS21 (15.7 kg in water)

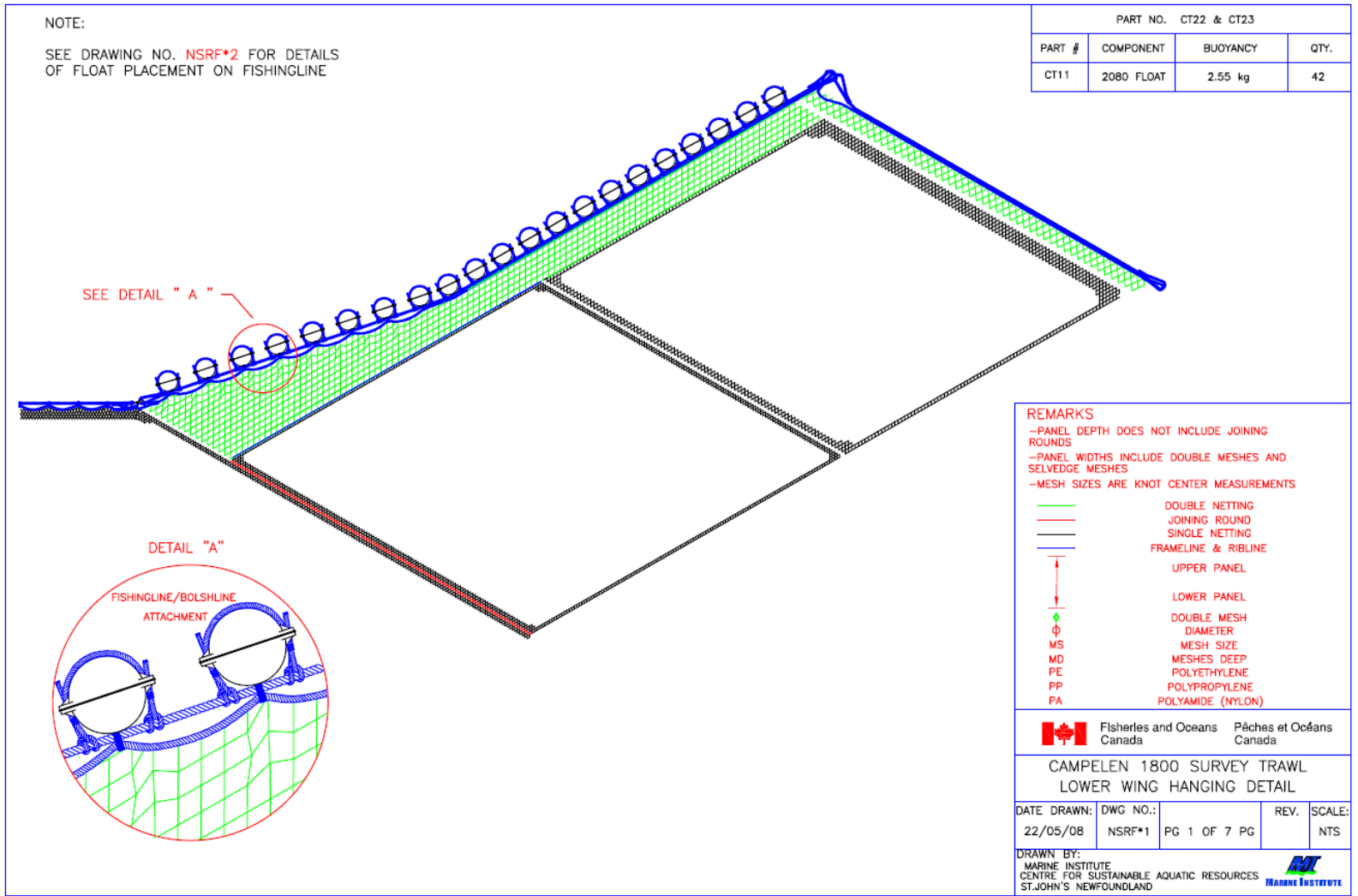

Appendix C Figure 1. Lower wing hanging detail.

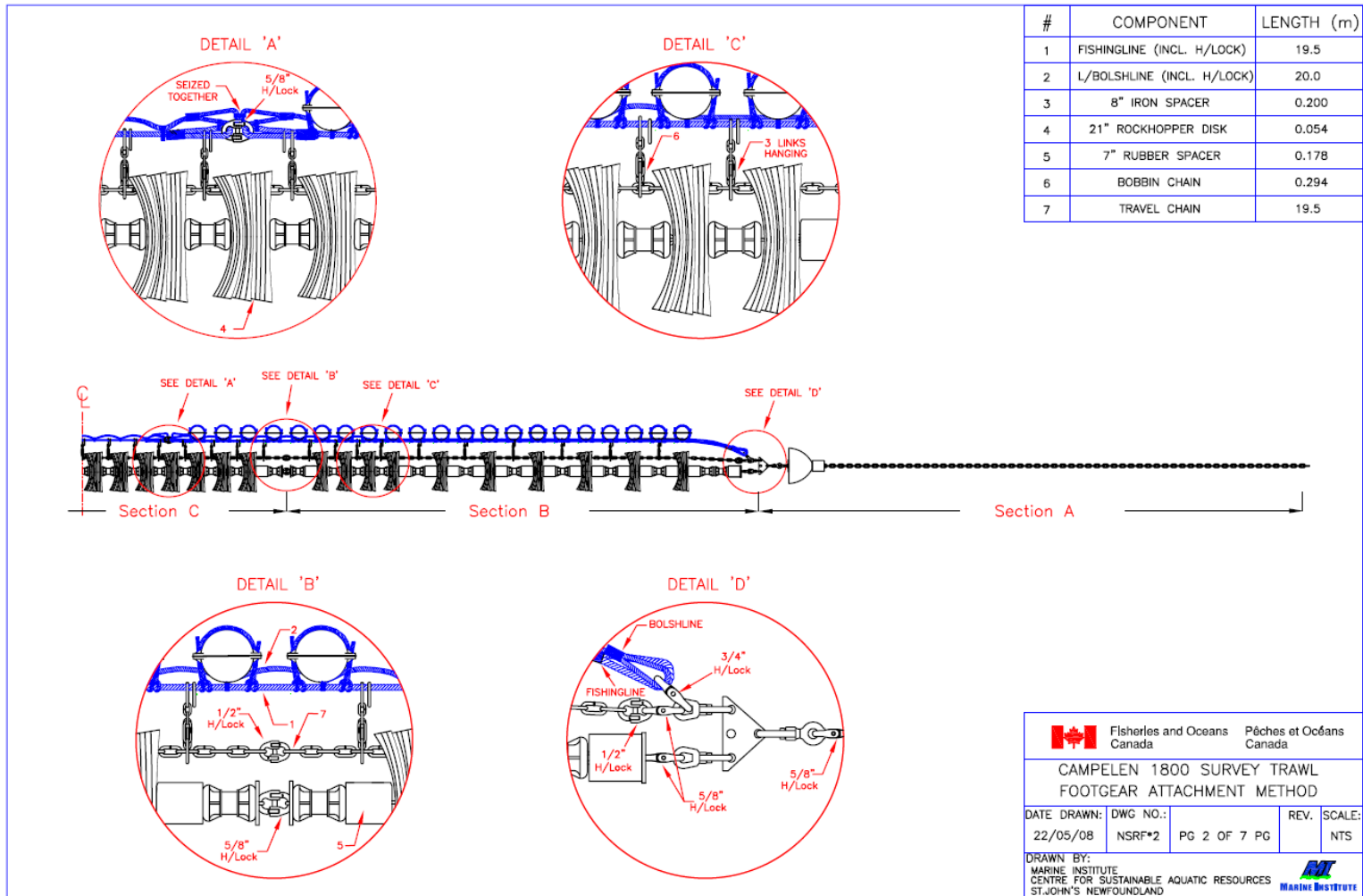

Appendix C Figure 2. Footgear attachment method.

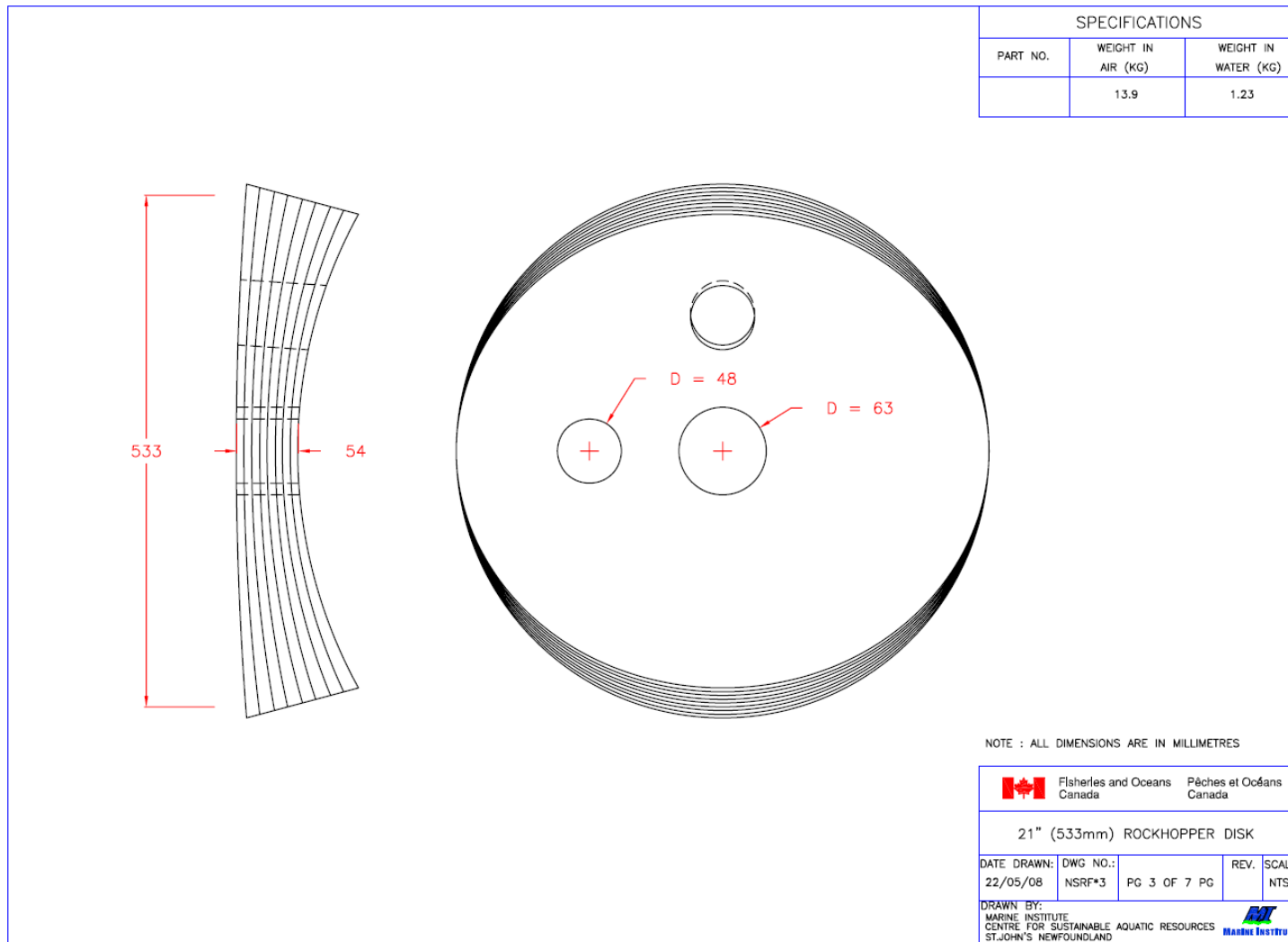

Appendix C Figure 3. 21 " Rockhopper disk.

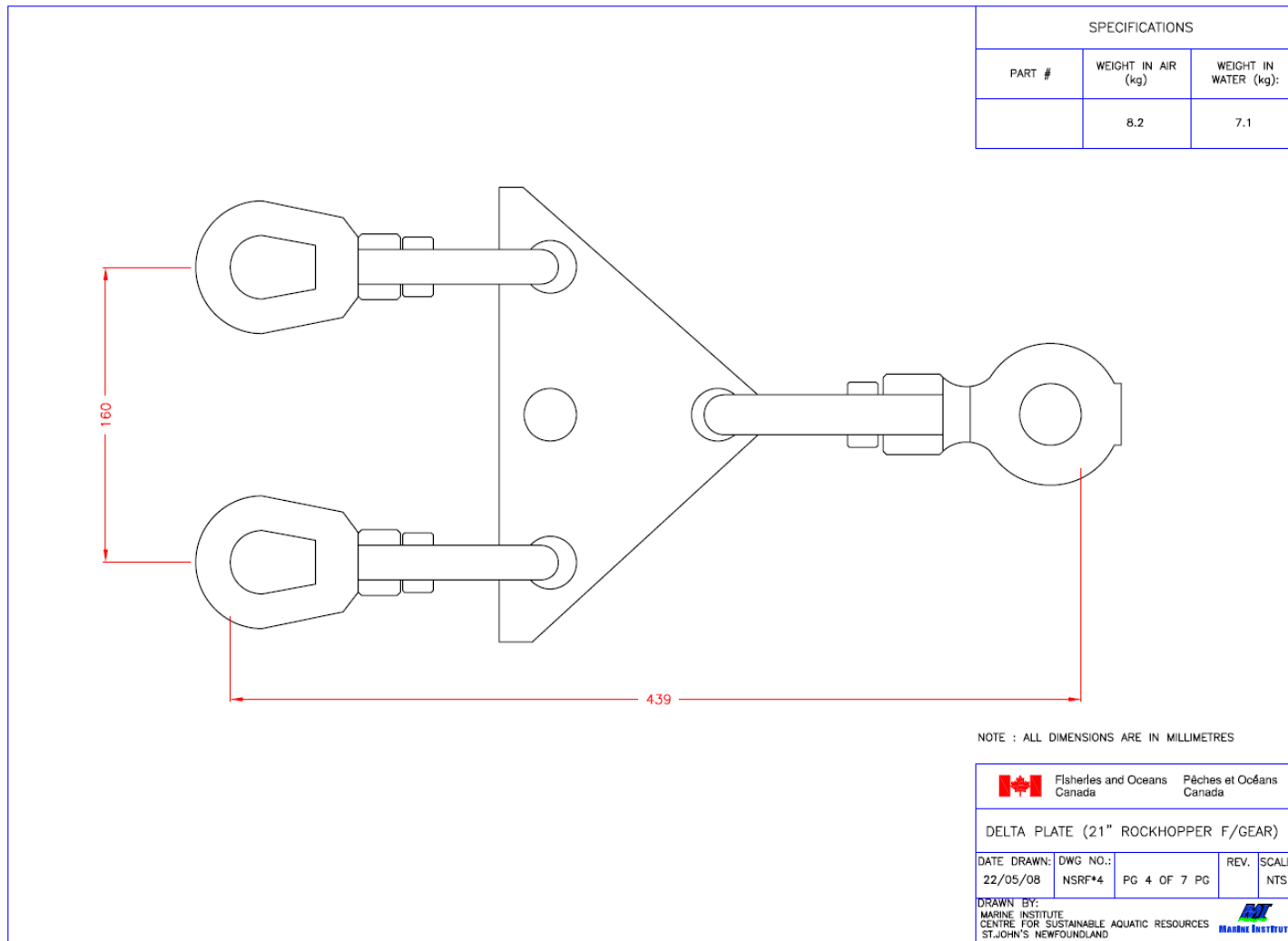

Appendix C Figure 4. Delta plate (21" rockhopper footgear).

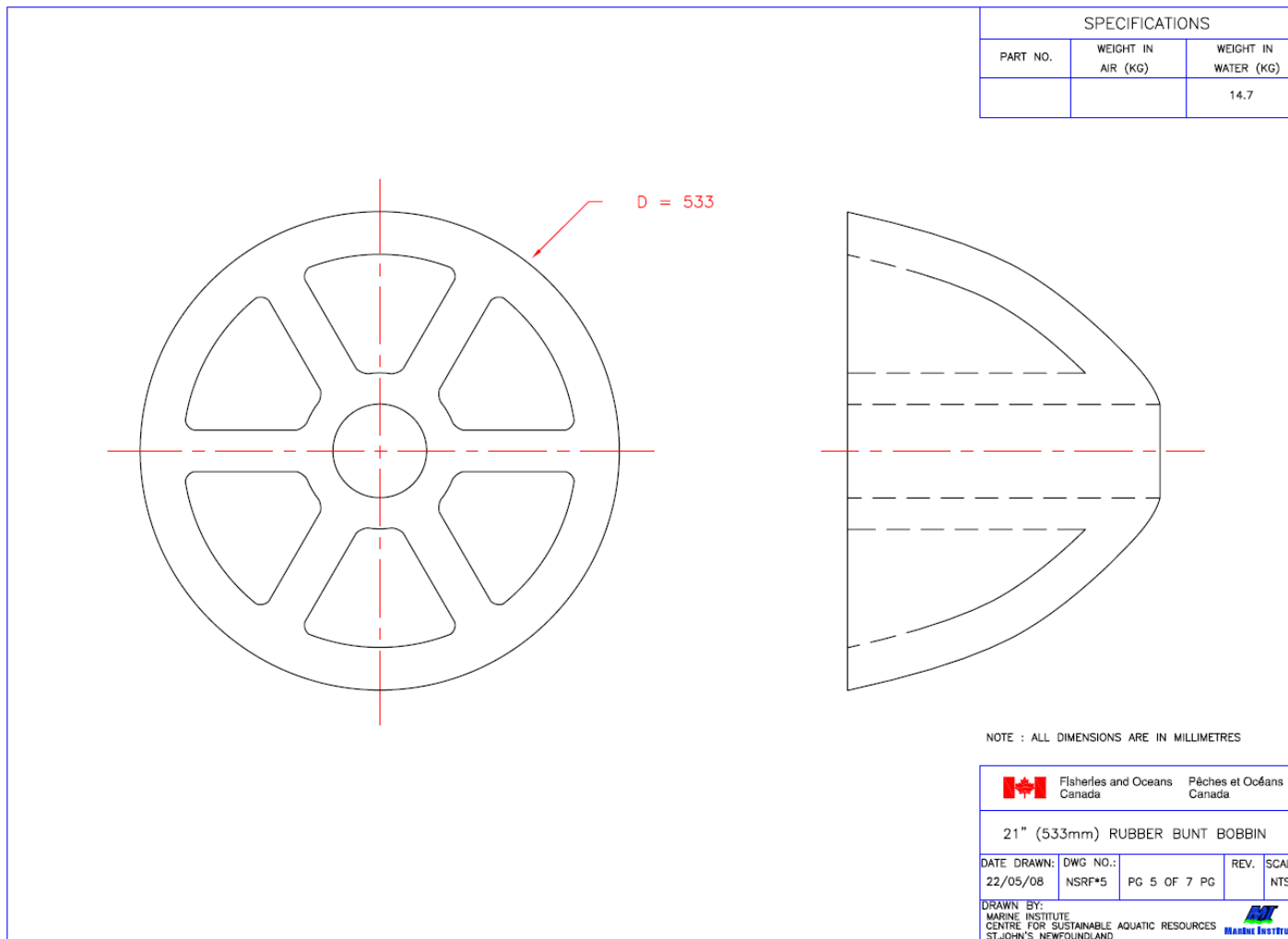

Appendix C Figure 5. 21" (533 mm) rubber bunt bobbin.



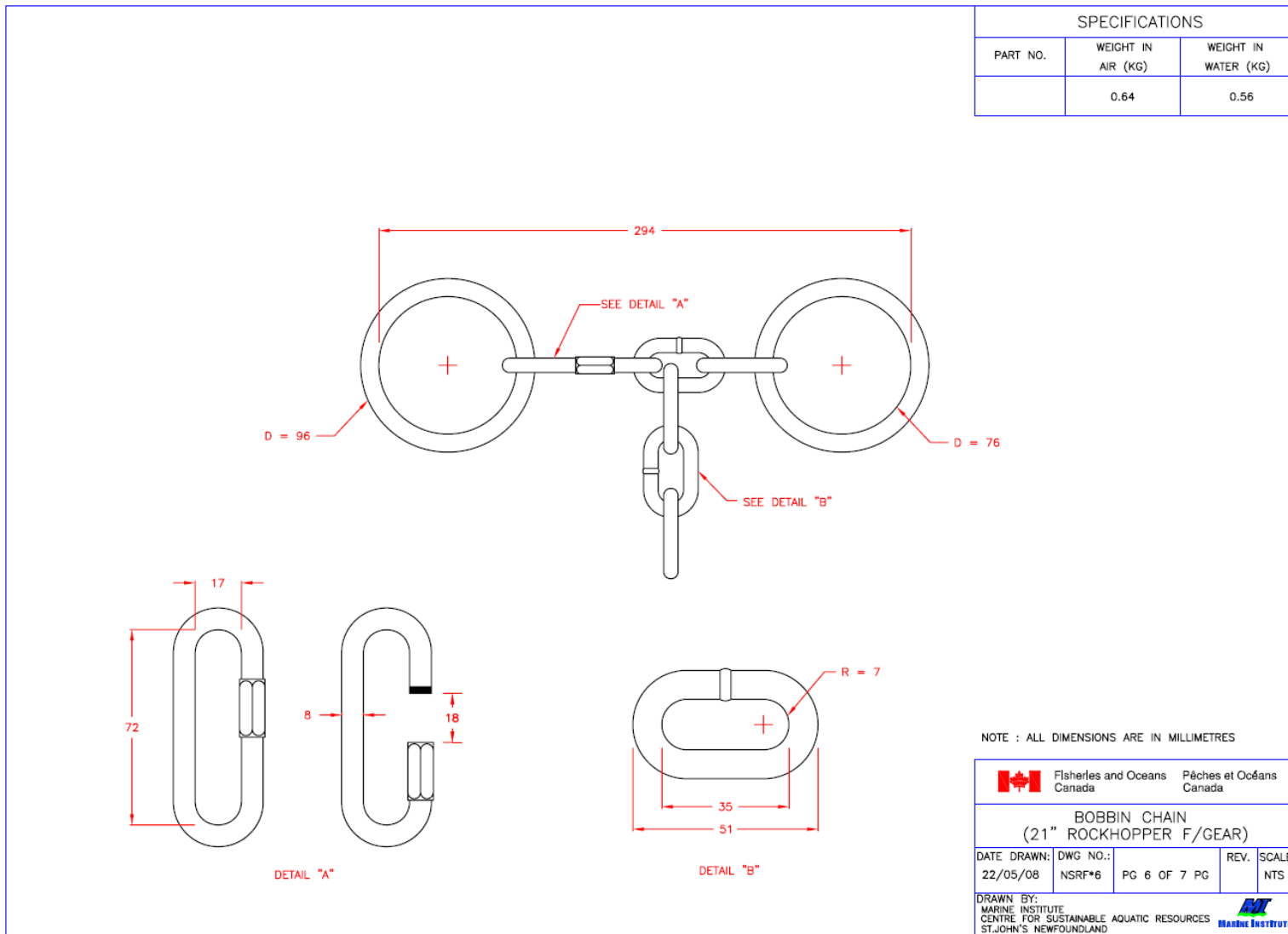

Appendix C Figure 6. Bobbin chain (21" rockhopper footgear).

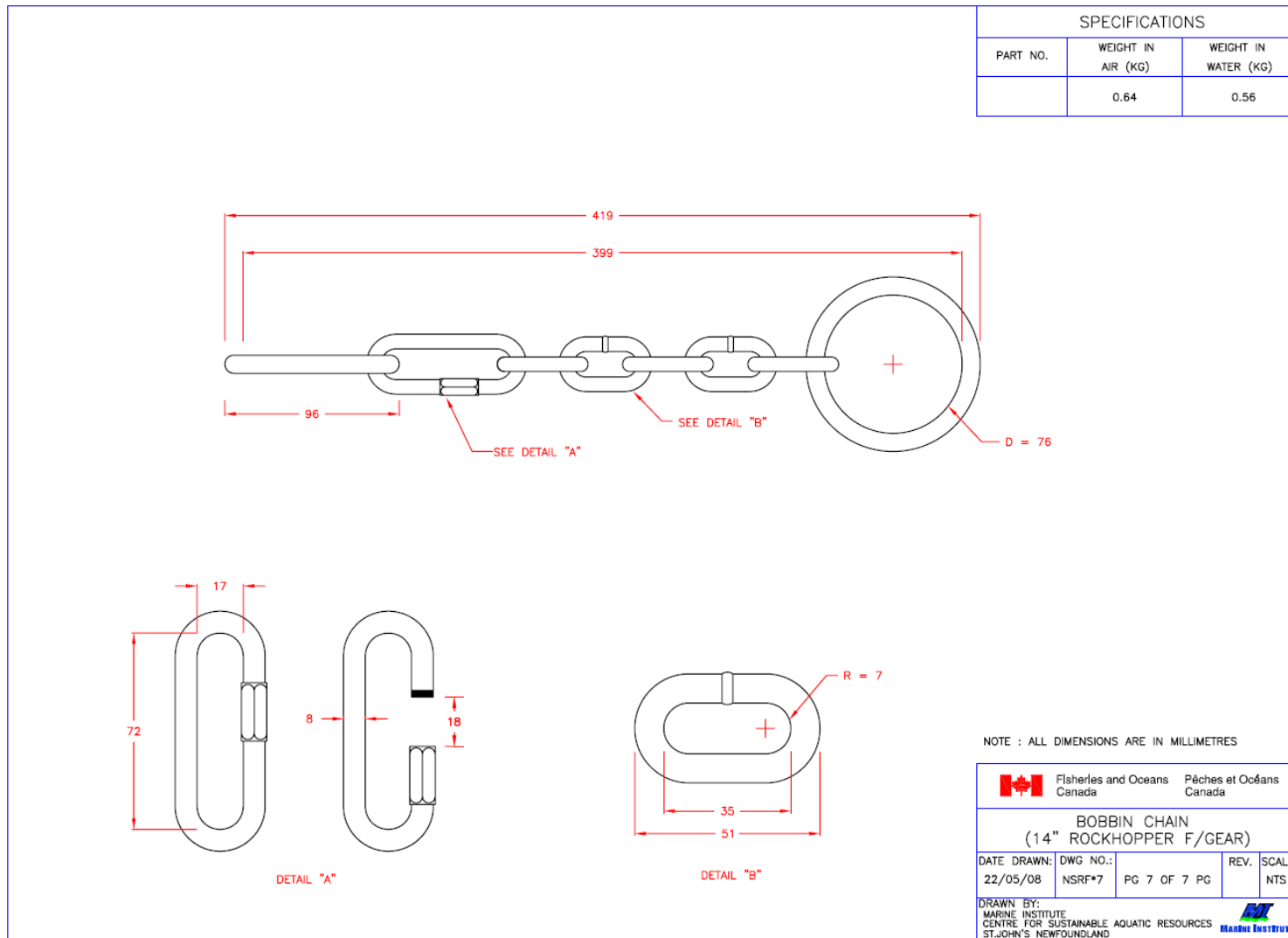

Appendix C Figure 7. Bobbin chain (14" rockhopper footgear).