

Not to be cited without
permission of the authors¹

Canadian Atlantic Fisheries
Scientific Advisory Committee

CAFSAC Research Document 92/72

Ne pas citer sans
autorisation des auteurs¹

Comité scientifique consultatif des
pêches canadiennes dans l'Atlantique

CSCPCA Document de recherche 92/72

Some Observations on the Biomass and Abundance of Fish Captured During Stratified Random Bottom Trawl Surveys in NAFO Divisions 2J3KL, Fall 1981-1991

by

D.B. Atkinson
Science Branch
Department of Fisheries and Oceans
P.O. Box 5667
St. John's, Newfoundland A1C 5X1

¹ This series documents the scientific basis for fisheries management advice in Atlantic Canada. As such, it addresses the issues of the day in the time frames required and the Research Documents it contains are not intended as definitive statements on the subjects addressed but rather as progress reports on ongoing investigations.

Research Documents are produced in the official language in which they are provided to the Secretariat by the author(s).

¹ Cette série documente les bases scientifiques des conseils de gestion des pêches sur la côte atlantique du Canada. Comme telle, elle couvre les problèmes actuels selon les échéanciers voulus et les Documents de recherche qu'elle contient ne doivent pas être considérés comme des énoncés finals sur les sujets traités mais plutôt comme des rapports d'étape sur les études en cours.

Les Documents de recherche sont publiés dans la langue officielle utilisée par les auteurs dans le manuscrit envoyé au secrétariat.

Abstract

Questions have been raised as to whether the observed declines in biomass of cod in NAFO Div. 2K3KL have been compensated for by increases in biomass of other species of marine life. This study examined the biomass of various fish species captured during annual fall research vessel surveys to see if increases coinciding with the decline in cod biomass could be detected. Declines in biomass were observed for all species examined. In most cases, the declines were greater than that for cod, and the proportion of cod biomass to total biomass showed some increase over time, particularly in Div. 2J. The declines in biomass were paralleled in most cases, by declines in abundance. It is still possible that compensatory increases in biomass have taken place in Div. 2J3KL in pelagic fish species, or non-fish species.

Résumé

Les déclinés observés dans la biomasse de morue des divisions 2J3KL de l'OPANO ont-ils été compensés par un accroissement de la biomasse d'autres espèces marines? La présente étude examine la biomasse de diverses espèces de poisson capturées au cours du relevé de recherche des stocks réalisée chaque année en automne, dans le but de déterminer si on peut déceler des augmentations coïncidant avec la diminution de la biomasse de morue. Or, on a observé une réduction de la biomasse de toutes les espèces examinées. Dans la plupart des cas, cette réduction était supérieure à celle observée pour la morue et la proportion de la biomasse de morue dans la biomasse totale reflétait un certain accroissement temporel, en particulier dans la division 2J. Dans la plupart des cas également, les reculs de la biomasse coïncidaient avec une diminution de l'abondance. Il est toutefois encore possible que des augmentations compensatoires de la biomasse se soient produites parmi le poisson pélagique ou des espèces marines autres que le poisson dans les divisions 2J3KL.

Introduction

Results of the most recent assessments of northern cod carried out by both CAFSAC and NAFO (May and June 1992 respectively) indicated that the stock had not increased as was perceived based on the assessment of May, 1991. This resulted in a discontinuation of the 3 year management plan, and a declaration, by the Minister, on July 2 of a 2 year moratorium. Of particular concern during this process was the dramatic decline in trawlable biomass observed during the 1991 fall survey as well as the disappearance of larger mature fish.

The survey results noted above prompted CAFSAC Steering Committee to question whether there were indications of any other fish species increasing in proportion to the observed decline in cod, thus 'filling the void.' Specifically, the Committee **recommended** that (a) *Research into the species composition of research survey catches should be undertaken in the context of potential large scale changes in community structure in the 2J3KL area (i.e. was there any compensatory response in other species in the ecosystem?).* and questioned (b) *Did abundance estimates of species other than cod also decrease in the 1991 survey?* These questions were to be directed to the newly formed Fisheries Oceanography Subcommittee of CAFSAC.

Annual fall stratified random bottom trawl surveys have been conducted in all of NAFO Div. 2J3KL beginning in 1981. Results of these surveys have been examined in conjunction with the assessments of a number of different species besides cod (e.g. redfish, Greenland halibut, witch flounder, American plaice and grenadiers). To date, there have been no attempts to bring the various estimates together as part of any holistic study.

The analyses presented here are of an exploratory nature, and represent attempts to address the questions posed by Steering Committee. Certain assumptions apply: there has been no systematic trend in catchability (q) over time, and there has been no systematic re-distribution of the various species between inside and outside the survey area over time. There has also been no consideration of the impact of commercial fisheries on any observed trends. For some species (e.g. redfish, Greenland halibut, American plaice), previous assessments have reported that the declines in biomass observed from the surveys cannot be explained by the fisheries.

Materials and Methods

Stratified random surveys have been conducted in NAFO Div. 2J, 3K and 3L during fall beginning in 1981. The surveys in 2J3K have consistently covered depths from 100-1000 m, while those in 3L were conducted from 50-200 fathoms (1981-1989) and 50-400 fathoms (1990-1991). Tows are usually of 30 min. duration with a small mesh liner used in the codend.

The data were extracted for a number of different fish species separately (cod, redfish, American plaice, Greenland halibut, witch flounder, roundnose grenadier, roughhead grenadier, skates [species combined]). The remainder of the species were grouped, and their catches totaled for each set.

Although the 'normal' procedure is to determine trawlable biomass or abundance using STRAP (Smith and Somerton 1981), for this study, I used ACON (Black MS 1991). This later procedure uses contouring (Watson 1982, Watson and Philip 1985) and the summation of the volume of all defined triangles (Delaunay) under the contoured surface (integration) approximates the total volume. From this, biomass or abundance can be determined. This method was employed because it enabled simultaneous contouring (mapping) of the data as desired. There are some differences in the results obtained from STRAP and ACON (Figure 1) but these are not considered to be sufficiently large to alter overall trends with time.

Trends in the biomass of cod compared to all other species separated and combined were examined for each division. The proportion of cod relative to the total trawlable biomass was also determined. The data were also partitioned to cod, other commercial species (COM) and non-commercial species (NONC). Least squares linear regressions of biomass on year were done for cod in all 3 divisions. For divisions with significant relationships for cod, regressions were also carried out of COM and NONC biomass on year.

Slopes of the different significant regressions were compared. The 1981 point for COM in Div. 2J was excluded from the analysis because the point was considered an outlier resulting from 2 very large catches of redfish. Contour plots illustrating the distribution of trawlable fish biomass were also prepared.

It has been observed off West Greenland that although there have been declines in biomass for many species in recent years, the decline in numbers has not been so great (Ratz 1991,1992). This indicated that the proportion of smaller fish had increased. In order to investigate whether a similar phenomenon has been taking place in Div. 2J3KL, ACON was also used to determine the abundance of the species and groups noted above. Trends in biomass and abundance with time were then compared.

Results and Discussion

No species or group demonstrated any trend in biomass that contrasted sharply with that for cod (Figure 2). Trends in the biomass of cod compared to all other species combined (Figure 3) are not generally dissimilar. In Div. 2J there was a decline for both groups, while further south in 3K and 3L, the decline in non-cod species seems to have been greater.

Thus from the data, there is no indication of any compensatory increase in other species paralleling the decline in cod. Instead, there appears to have been an overall decline in all species. In each of the divisions, the proportion of cod to the total biomass actually appears to increase over the 11 year time (Figure 4). This might suggest that cod itself is a compensatory species in the face of observed declines.

Regression analysis indicated that only in Div. 2J is the decline for cod significant ($p < 0.05$) (Table 1). This relationship is not significant without 1990 and 1991. Regressions of COM and NONC were also significant for this division ($p < 0.05$) (Table 2). Comparison of slopes of COM and NONC to that of cod in Div. 2J (Table 3, Figure 5) indicated that the differences were not significant ($p < 0.05$).

Contour plots (Figure 6) indicate wide scale distribution of densities > 100 kg per tow during the early 1980s. There was a decline in density on top of some of the banks in the 1984/85 period, probably related to the cold water temperatures during that period. With time, however, it is also obvious that the amount of area with the > 100 kg densities steadily declined. Even in 1986, a year identified as yielding anomalously high biomass estimates for cod and other species, this trend was sustained. The trends from 1989 through 1991 are particularly dramatic and suggest not only a decline, but a concentration of the remaining biomass in the offshore areas away from the coast.

Comparisons of trends in biomass and abundance for the various species indicate that abundance has declined simultaneously in many cases (Figure 7, 8 and 9), but in some instances such as turbot in Div. 3K it did not. This may be related to recruitment of relatively strong year classes of the mid-1980s. It also appears that the abundance of other species has increased although the overall biomass declined. This is most noticeable in Div. 3K and 3L. A closer examination of these data is required to determine if there has been a shift in species mix or from larger to smaller individuals within any one species. Ratz (1991) interpreted the declines in biomass off West Greenland to be indicative of "ecosystem stress". It is reasonable to believe that the wide spread declines observed in Div. 2J3KL are also the result of ecosystem stress, although the nature of the stress is unclear. It may encompass a number of factors including fishing pressure, environment and predator-prey relationships.

Summary and Conclusions

1. The declines observed for cod in 2J3KL are not compensated for by any dramatic increases in the biomass of other fish species caught during the annual fall bottom trawl surveys. Instead, general declines in biomass were noted for all species or species groups examined. This does not preclude increases in biomass having occurred for pelagic fish species or non-fish species.
2. The proportion of cod to the total biomass of fish actually appeared to increase over the 11 year period perhaps indicating that cod itself is compensating to some degree for the decline in other species. (Although the increase in proportion in Div. 2J cannot be considered statistically significant since the slopes of the various declining biomasses were not statistically different.)

3. The declines observed for biomass were also reflected in fish abundance in most cases although a few exceptions were observed.
3. In order to properly address the issues and questions, we must ensure that our horizons are broad enough by:
 - a) not focusing only on the environmental events of 1991 and their possible impacts on cod. Large scale environmental events happening over broader periods of time must be considered.
 - b) not focusing on any particular species (e.g. cod, or capelin, or salmon). Something seems to be occurring which is impacting on a wide variety of fish species (and possibly other marine organisms as well) and a more holistic approach is required.

References

- Smith, S.J. and G.D. Somerton. 1981. STRAP: A User-Oriented Computer Analysis System for Groundfish Research Trawl Survey Data. Can. Tech. Rep. Fish. Aquat. Sci. 1030: iv + 66 p.
- Black, G.A.P. 1991. ACON: Documentation for ACON Version 5.02. Unpubl. Manuscript. 148p.
- Ratz, H-J. 1991. Notes of the Structure and Changes in the Ichthyofauna off West Greenland. NAFO SCR Doc. 91/36. Ser. No. N1916, 16p.
- Ratz, H-J. 1992. Decrease in Fish Biomass off West Greenland (Subdivisions 1B-1F) Continued. NAFO SCS Doc. 92/40. Ser. No. N2088, 8p.
- Watson, D.F. 1982. ACORD - Automatic Contouring of Raw Data. Comp. & Geosci. 8: 97-101.
- Watson, D.F. and G.M. Philip. 1985. A Refinement of Inverse Distance Weighted Interpolation. Geo-Processing 2: 315-327.

Table 1: Results of regression analyses of cod biomass vs. time.

Division 2J

DEP VAR: COD N: 11 MULTIPLE R: 0.623 SQUARED MULTIPLE R: 0.388
 ADJUSTED SQUARED MULTIPLE R: 0.320 STANDARD ERROR OF ESTIMATE: 70296.2060

VARIABLE	COEFFICIENT	STD ERROR	STD COEF	TOLERANCE	T	P(2 TAIL)
CONSTANT	.319799E+08	.133111E+08	0.0000	.	2.4025	0.0397
YEAR	-16001.8091	6702.4803	-0.6227	1.0000	-2.3874	0.0407

ANALYSIS OF VARIANCE

SOURCE	SUM-OF-SQUARES	DF	MEAN-SQUARE	F-RATIO	P	SIG.
REGRESSION	.281664E+11	1	.281664E+11	5.6999	0.0407	SIG.
RESIDUAL	.444740E+11	9	.494156E+10			

Division 3K

DEP VAR: COD N: 11 MULTIPLE R: 0.166 SQUARED MULTIPLE R: 0.028
 ADJUSTED SQUARED MULTIPLE R: 0.000 STANDARD ERROR OF ESTIMATE: 86321.1675

VARIABLE	COEFFICIENT	STD ERROR	STD COEF	TOLERANCE	T	P(2 TAIL)
CONSTANT	-.805514E+07	.163456E+08	0.0000	.	-0.4928	0.6340
YEAR	4155.7727	8230.4004	0.1660	1.0000	0.5049	0.6257

ANALYSIS OF VARIANCE

SOURCE	SUM-OF-SQUARES	DF	MEAN-SQUARE	F-RATIO	P	SIG.
REGRESSION	.189975E+10	1	.189975E+10	0.2550	0.6257	N.S.
RESIDUAL	.670621E+11	9	.745134E+10			

Division 3L

DEP VAR: COD N: 11 MULTIPLE R: 0.166 SQUARED MULTIPLE R: 0.028
 ADJUSTED SQUARED MULTIPLE R: 0.000 STANDARD ERROR OF ESTIMATE: 86321.1675

VARIABLE	COEFFICIENT	STD ERROR	STD COEF	TOLERANCE	T	P(2 TAIL)
CONSTANT	-.805514E+07	.163456E+08	0.0000	.	-0.4928	0.6340
YEAR	4155.7727	8230.4004	0.1660	1.0000	0.5049	0.6257

ANALYSIS OF VARIANCE

SOURCE	SUM-OF-SQUARES	DF	MEAN-SQUARE	F-RATIO	P	SIG.
REGRESSION	.189975E+10	1	.189975E+10	0.2550	0.6257	N.S.
RESIDUAL	.670621E+11	9	.745134E+10			

Table 2: Results of regression analyses of other commercial species (COM) and non-commercial species (NONC) biomass vs. time for Div. 2J.

DEP VAR: **COM (excl. 1981)** N: 10 MULTIPLE R: 0.916 SQUARED MULTIPLE R: 0.839
 ADJUSTED SQUARED MULTIPLE R: 0.818 STANDARD ERROR OF ESTIMATE: 40298.1454

VARIABLE	COEFFICIENT	STD ERROR	STD COEF	TOLERANCE	T	P(2 TAIL)
CONSTANT	.569824E+08	.881347E+07	0.0000	.	6.4654	0.0002
YEAR	-28598.1576	4436.6798	-0.9157	1.0000	-6.4458	0.0002

ANALYSIS OF VARIANCE

SOURCE	SUM-OF-SQUARES	DF	MEAN-SQUARE	F-RATIO	P	SIG.
REGRESSION	.674730E+11	1	.674730E+11	41.5489	0.0002	SIG.
RESIDUAL	.129915E+11	8	.162394E+10			

DEP VAR: **NONC** N: 11 MULTIPLE R: 0.909 SQUARED MULTIPLE R: 0.827
 ADJUSTED SQUARED MULTIPLE R: 0.808 STANDARD ERROR OF ESTIMATE: 9209.3438

VARIABLE	COEFFICIENT	STD ERROR	STD COEF	TOLERANCE	T	P(2 TAIL)
CONSTANT	.114770E+08	.174386E+07	0.0000	.	6.5814	0.0001
YEAR	-5755.6455	878.0765	-0.9093	1.0000	-6.5548	0.0001

ANALYSIS OF VARIANCE

SOURCE	SUM-OF-SQUARES	DF	MEAN-SQUARE	F-RATIO	P	SIG.
REGRESSION	.364402E+10	1	.364402E+10	42.9658	0.0001	SIG.
RESIDUAL	.763308E+09	9	.848120E+08			

Table 3: Results of comparison of slopes of cod with those of other commercial species (COM) and non-commercial species (NONC) in Div. 2J.

Commercial Species (excl. 1981)

LEVELS ENCOUNTERED DURING PROCESSING ARE:

CAT\$

COD COM

DEP VAR: **BIOMASS** N: 21 MULTIPLE R: 0.797 SQUARED MULTIPLE R: 0.635

ANALYSIS OF VARIANCE

SOURCE	SUM-OF-SQUARES	DF	MEAN-SQUARE	F-RATIO	P	
YEAR	.937745E+11	1	.937745E+11	27.7413	0.0001	
CAT\$.746962E+10	1	.746962E+10	2.2097	0.1555	
YEAR*CAT\$.748006E+10	1	.748006E+10	2.2128	0.1552	N.S.
ERROR	.574655E+11	17	.338033E+10			

Non-Commercial Species

LEVELS ENCOUNTERED DURING PROCESSING ARE:

CAT\$

COD NONC

DEP VAR: **BIOMASS** N: 22 MULTIPLE R: 0.884 SQUARED MULTIPLE R: 0.782

ANALYSIS OF VARIANCE

SOURCE	SUM-OF-SQUARES	DF	MEAN-SQUARE	F-RATIO	P	
YEAR	.260363E+11	1	.260363E+11	10.3599	0.0048	
CAT\$.586180E+10	1	.586180E+10	2.3324	0.1441	
YEAR*CAT\$.577411E+10	1	.577411E+10	2.2975	0.1469	N.S.
ERROR	.452373E+11	18	.251318E+10			

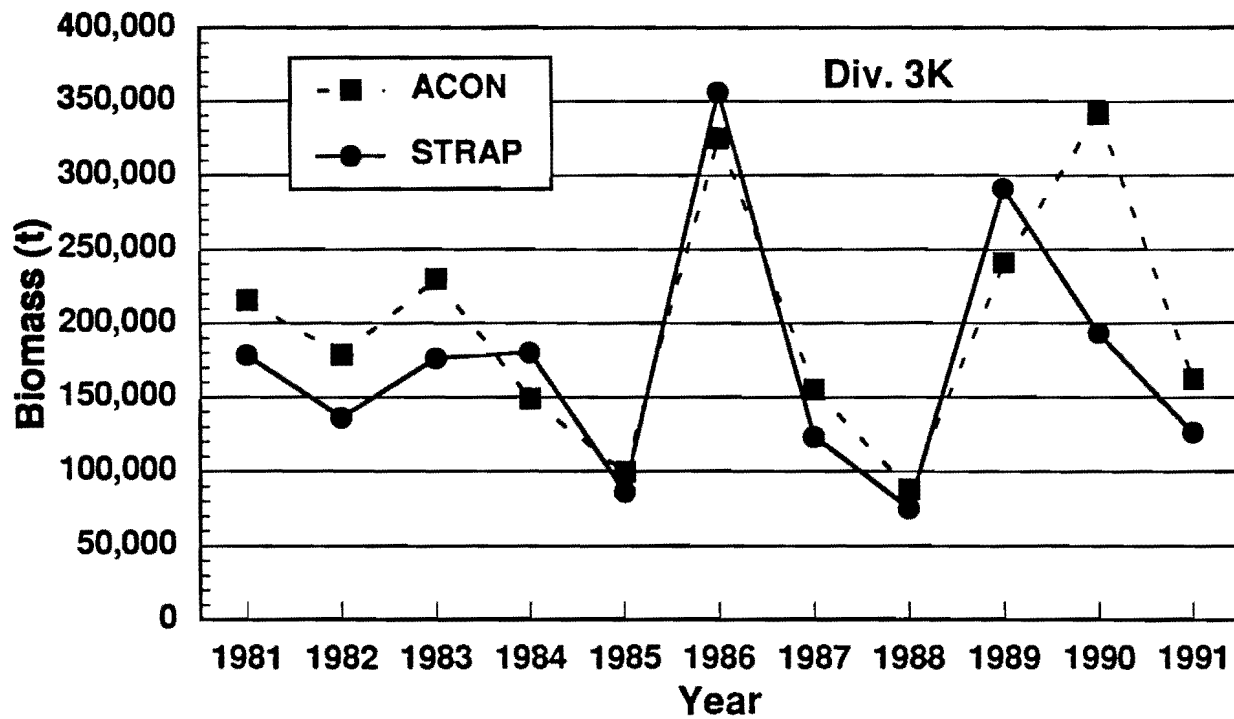
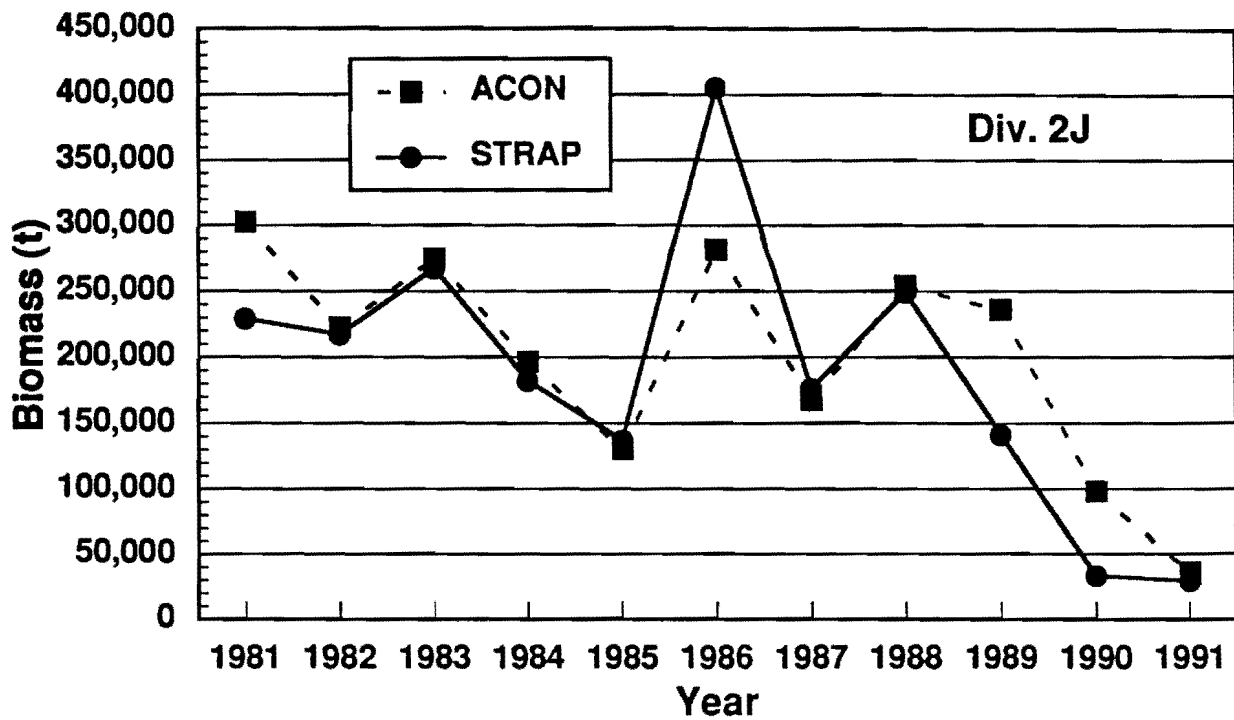

Figure 1: Comparison of biomass estimates from STRAP and ACON for Div. 2J3KL cod.

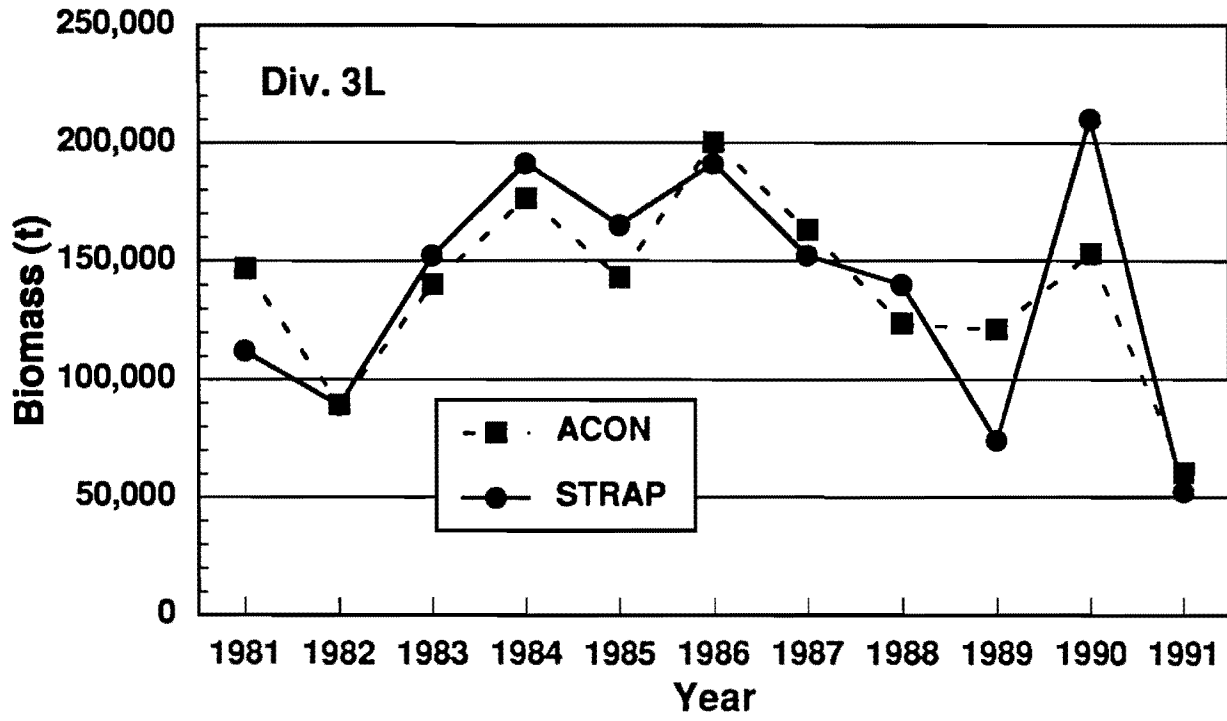

Figure 1: Continued

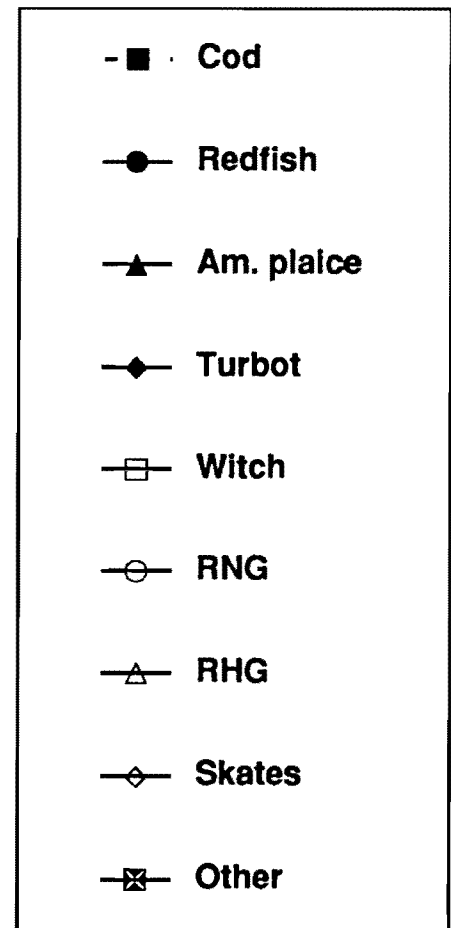
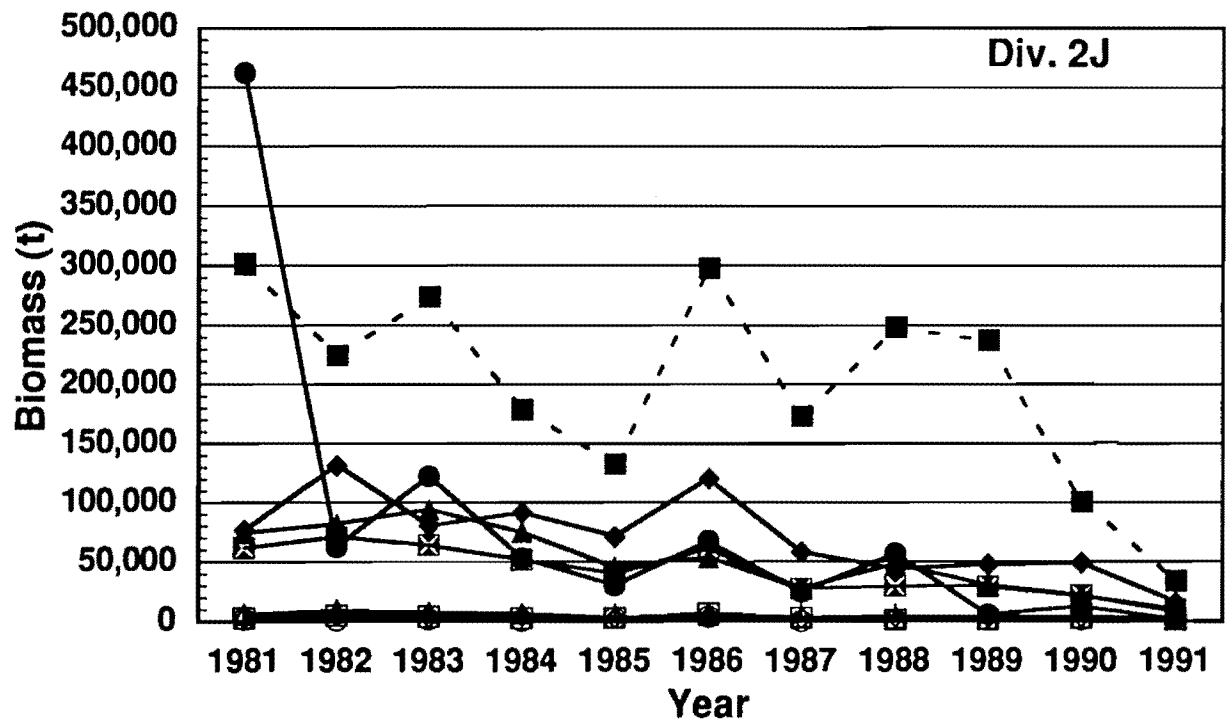

Figure 2: Biomass estimates for the various species and groups examined by Division.

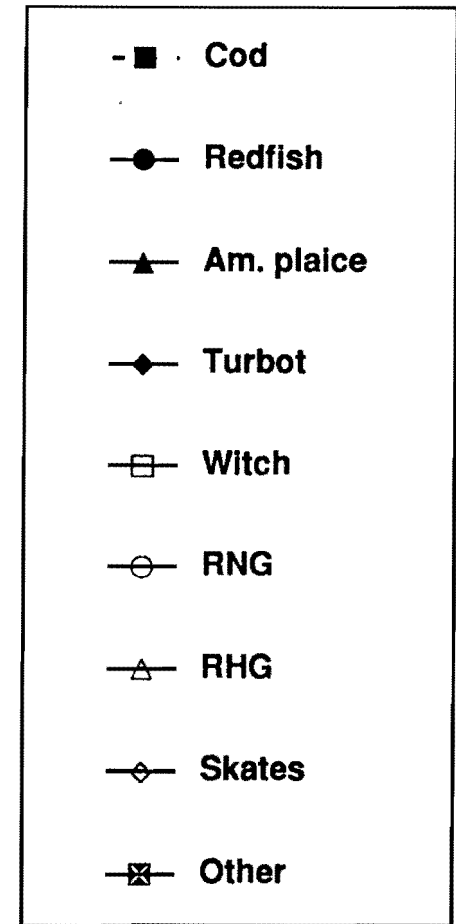
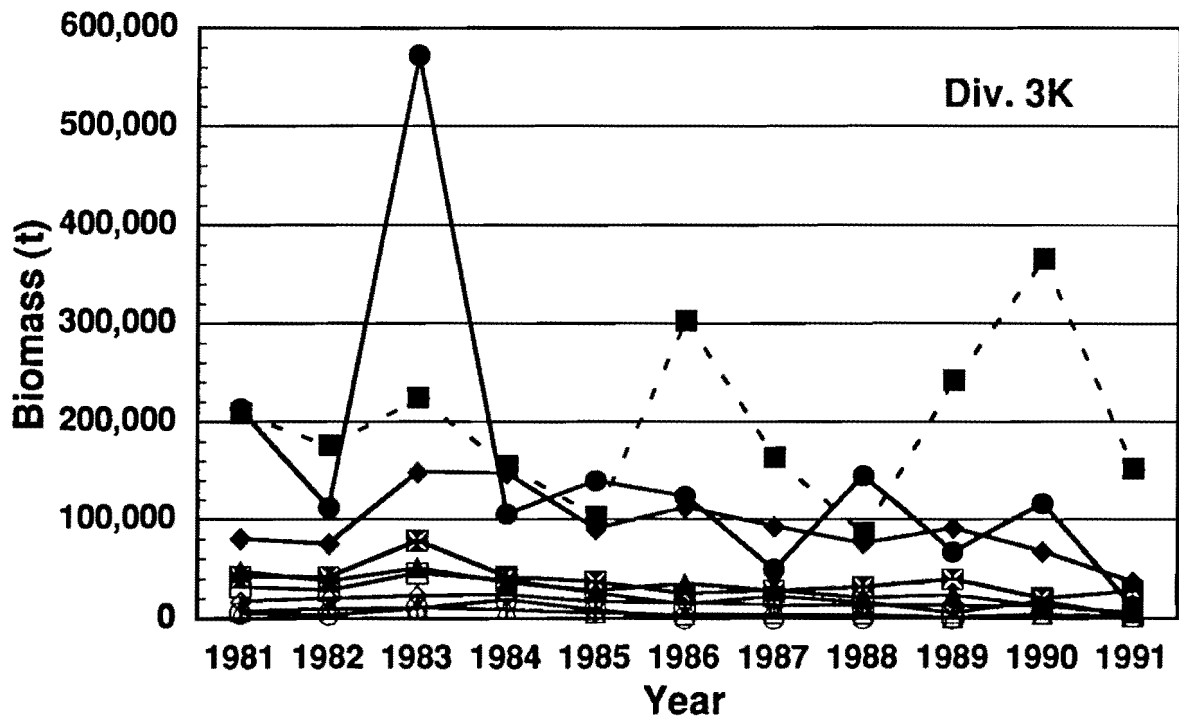

Figure 2: Continued.

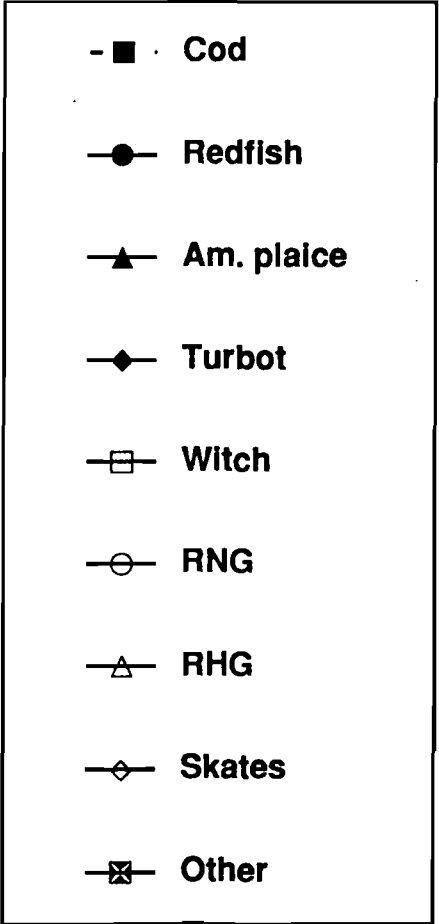
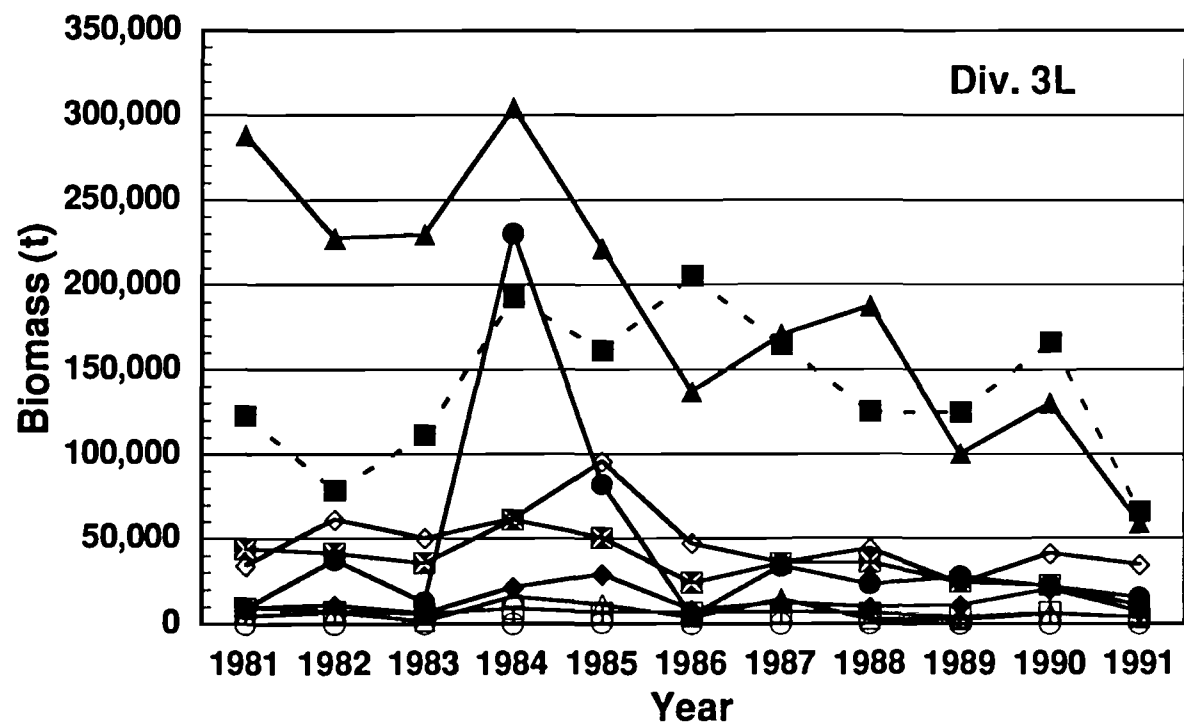

Figure 2: Continued.

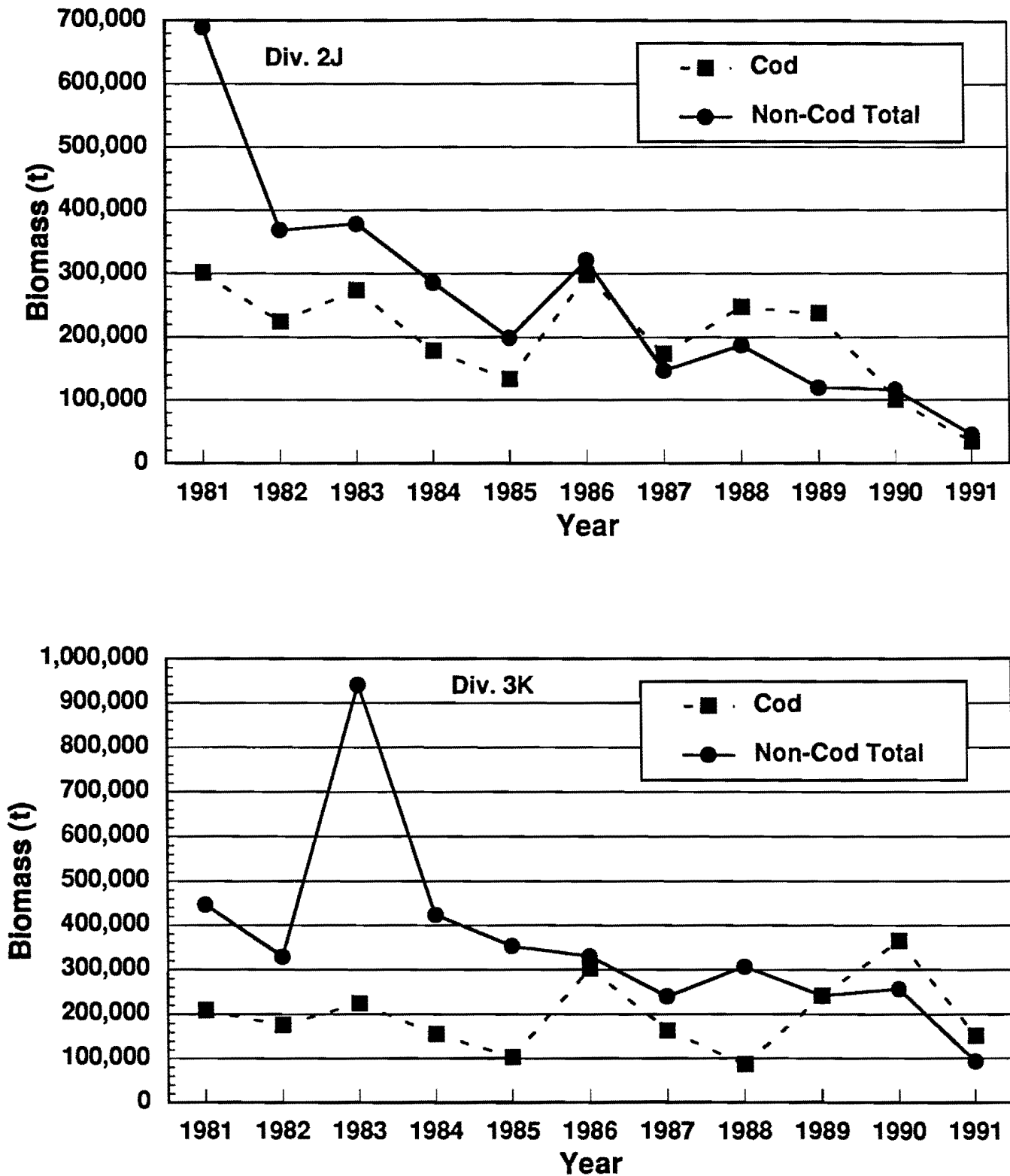

Figure 3: Comparisons of biomass for cod and non-cod species estimated from bottom trawl surveys in 2J3KL, 1981-1991.

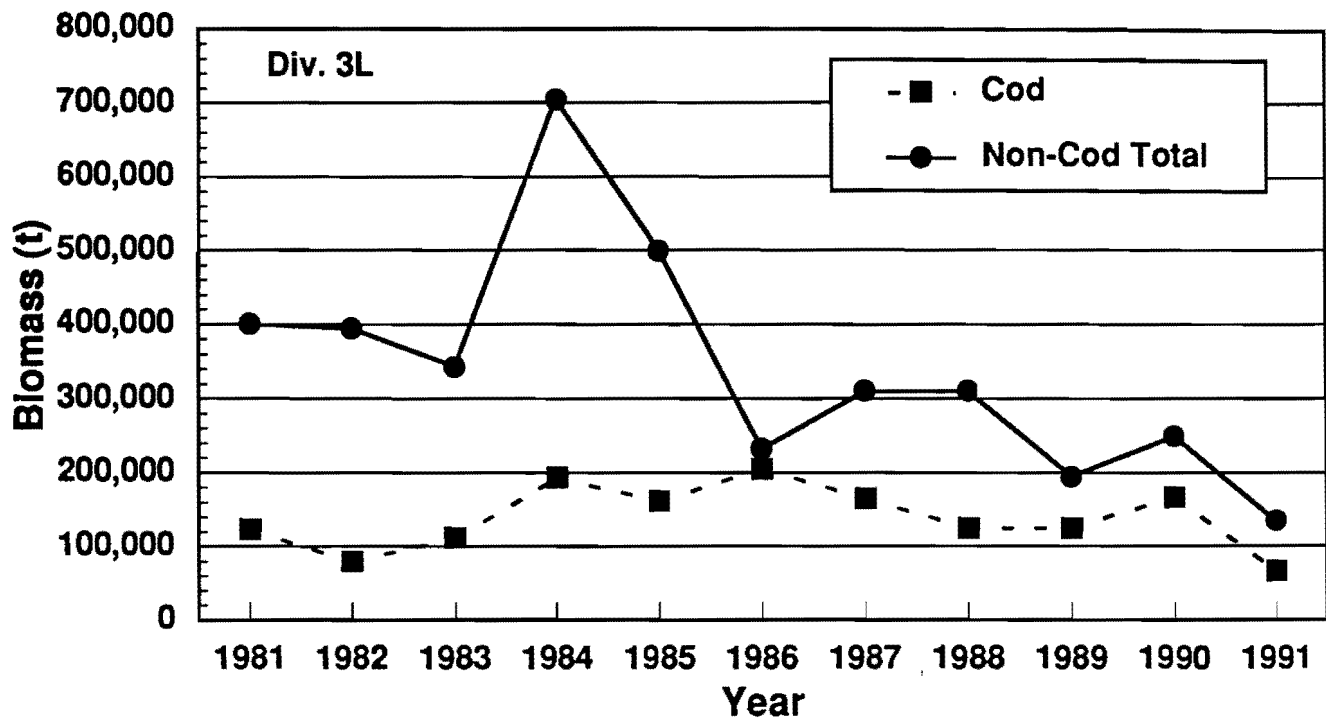

Figure 3: Continued.

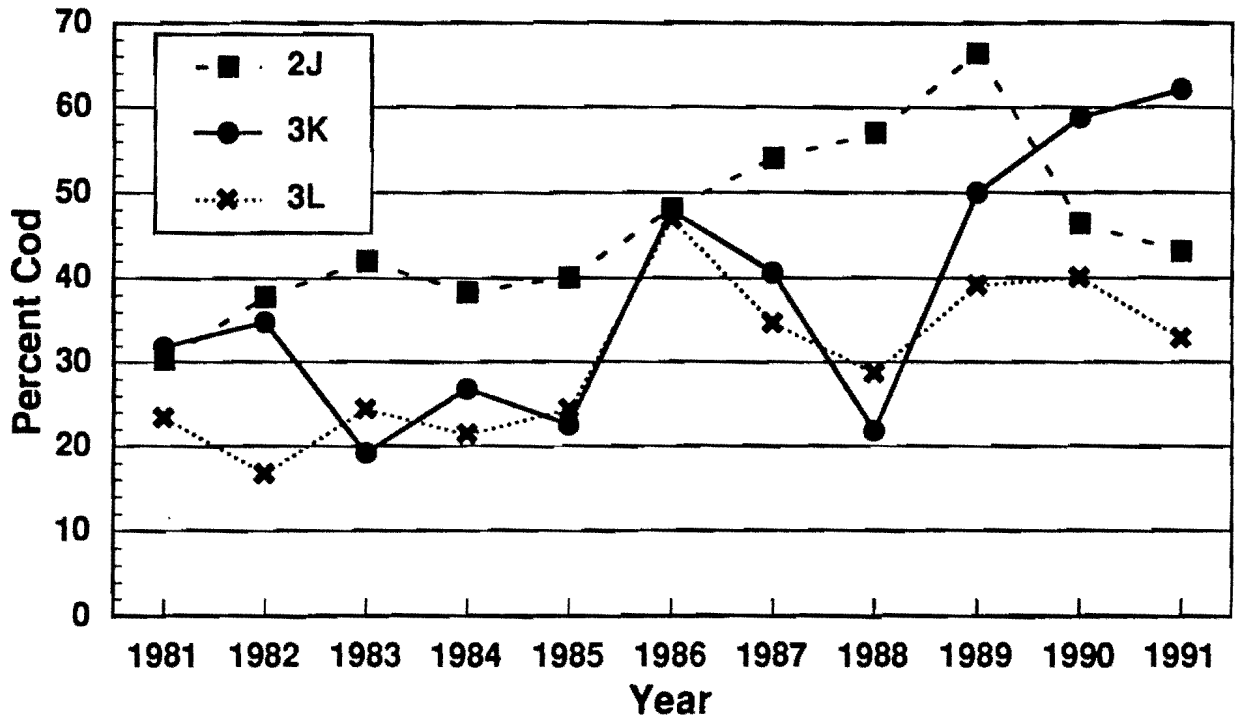

Figure 4: Percentage that cod represents of total estimated biomass.

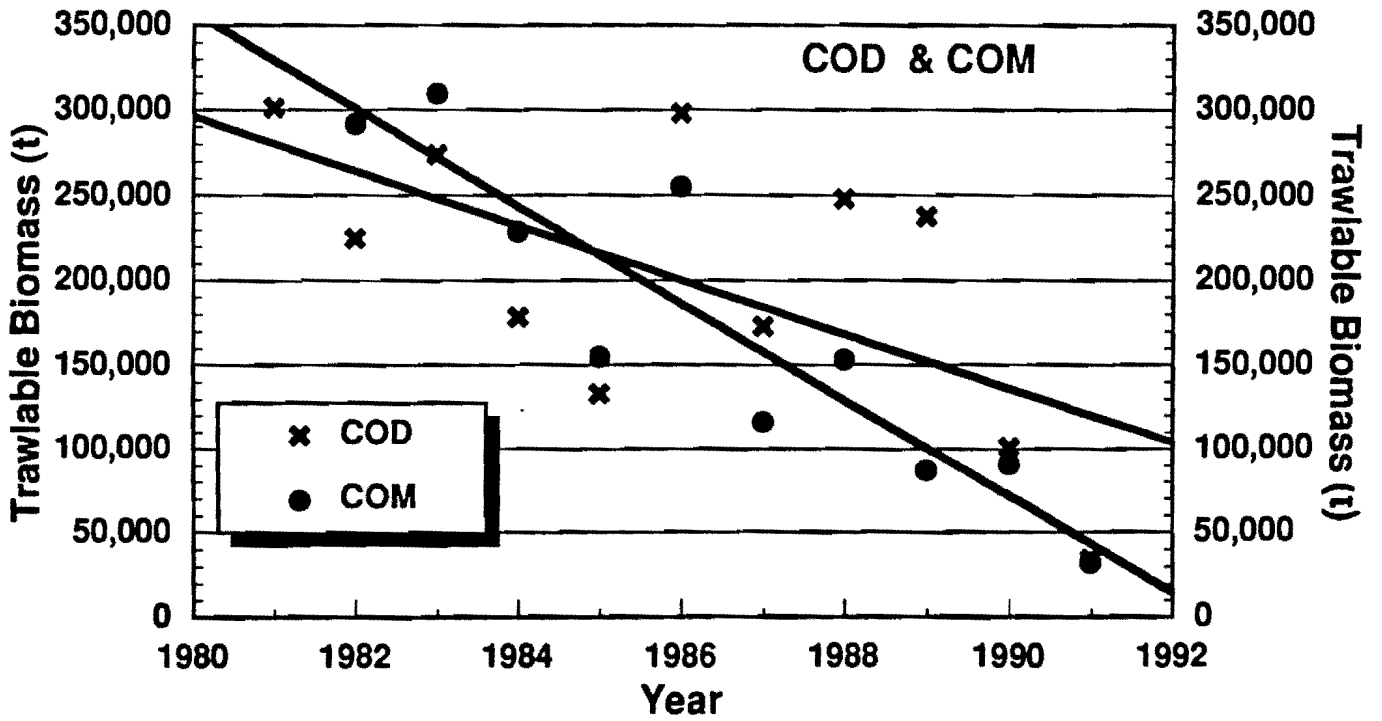

Figure 5: Regression of biomass on year for cod and other commercial species (COM) and non-commercial species (NONC) in Div. 2J.

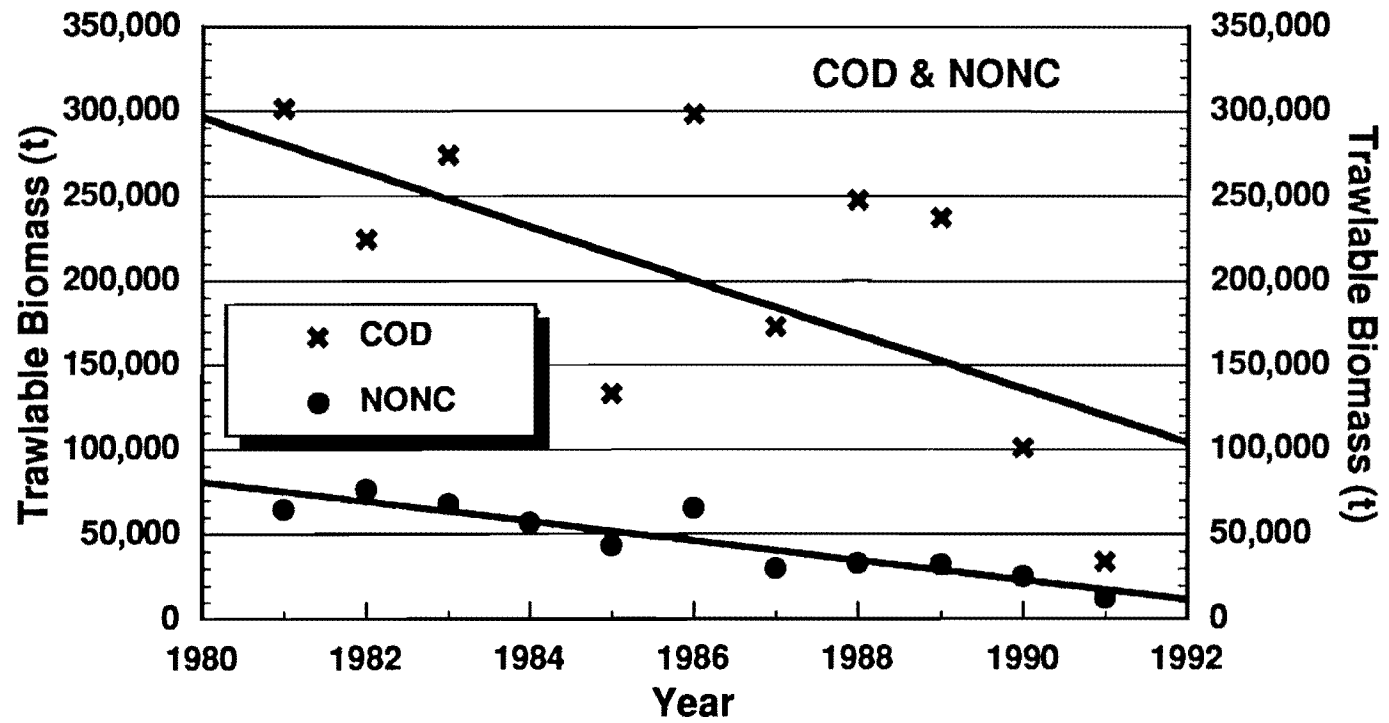

Figure 5: Continued

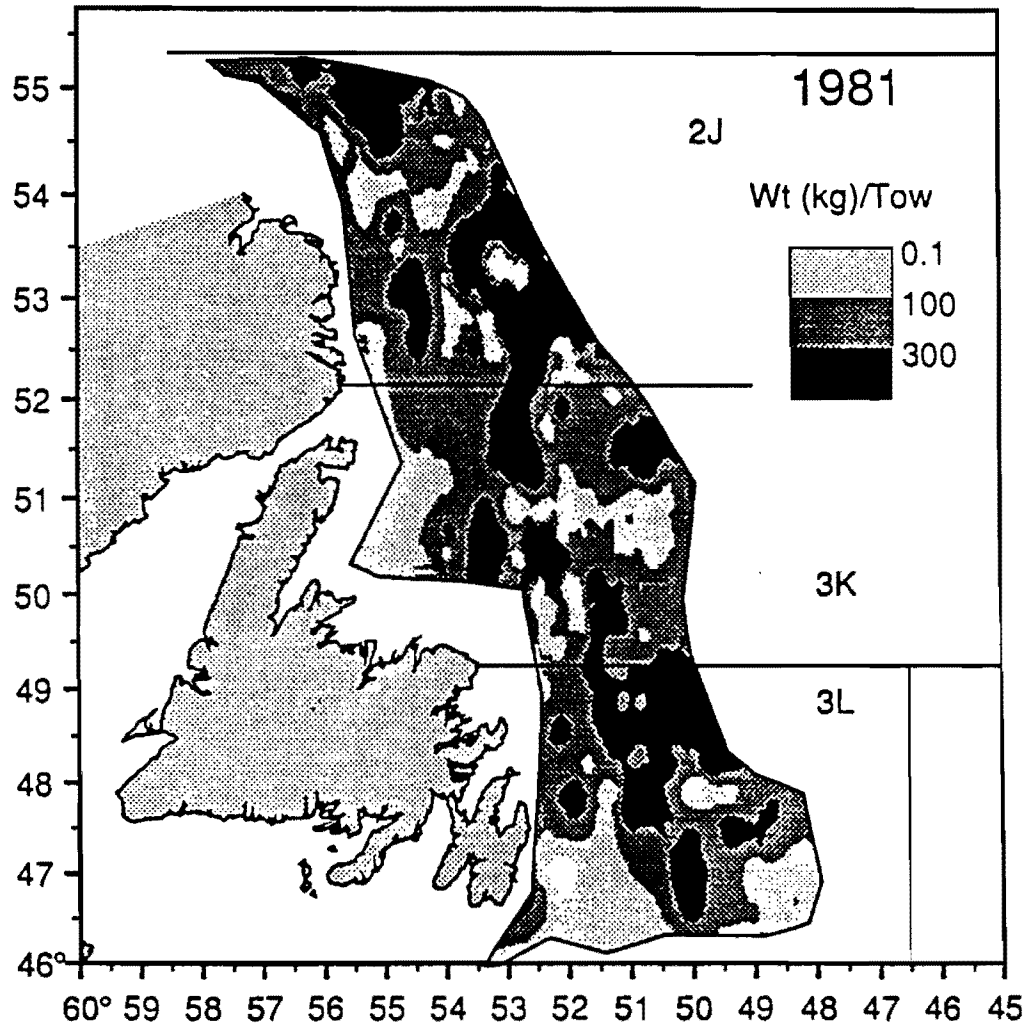

Figure 6: Distribution of trawlable fish biomass in Div. 2J3KL from fall stratified random surveys, 1981 - 1991.

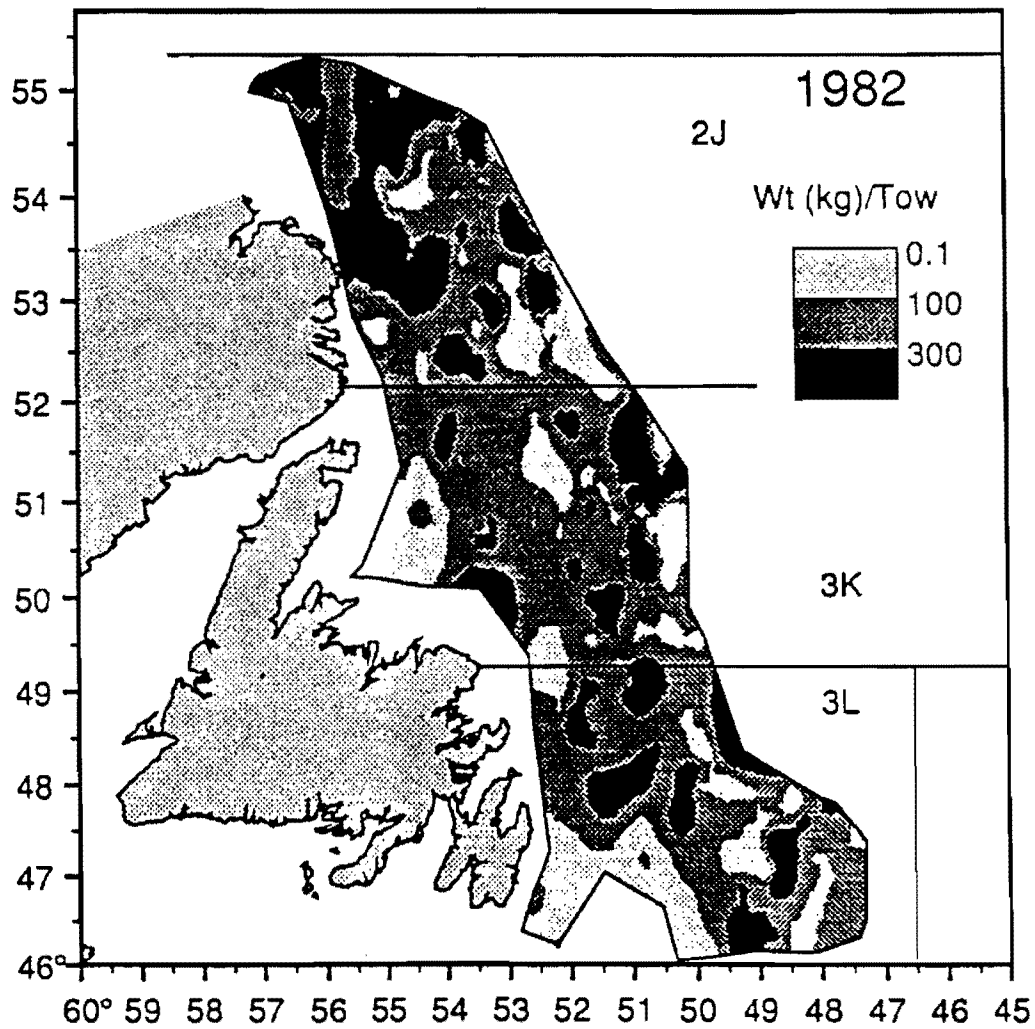

Figure 6: Continued.

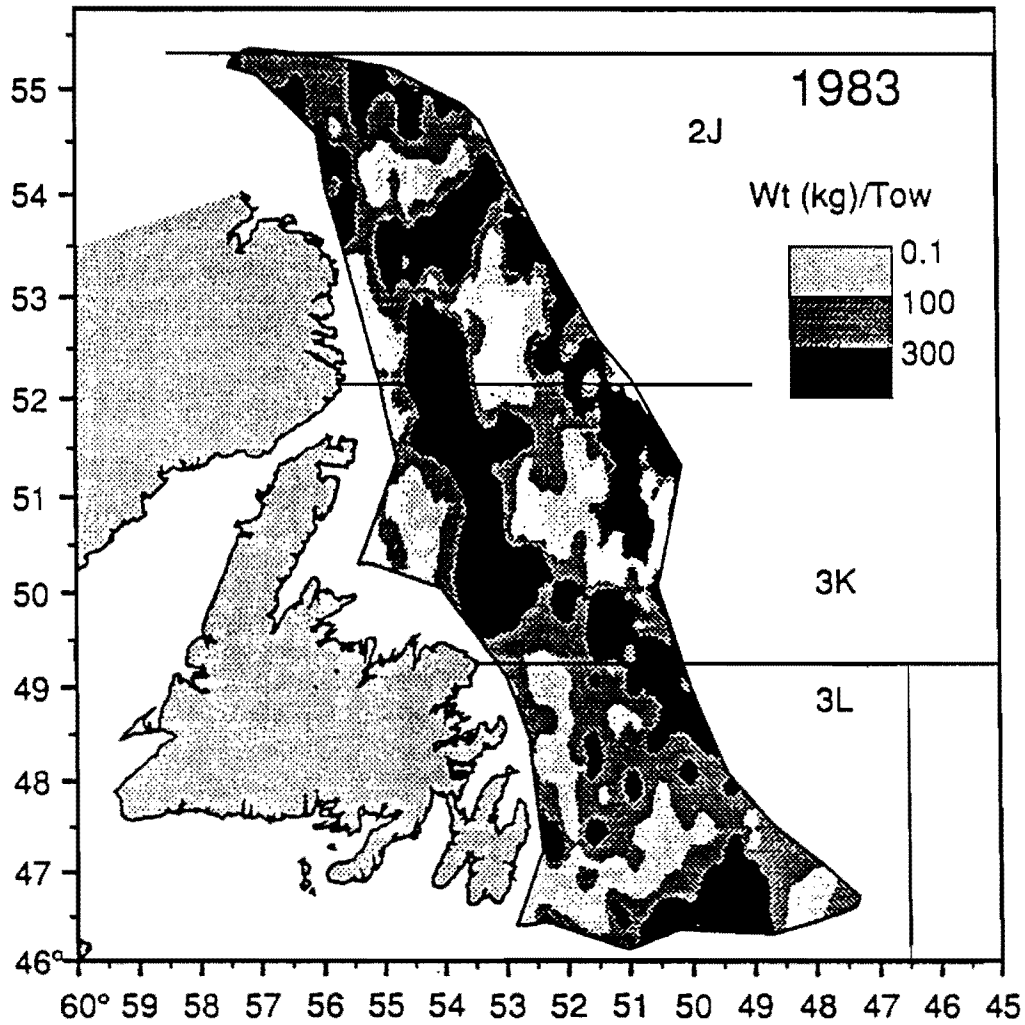

Figure 6: Continued.

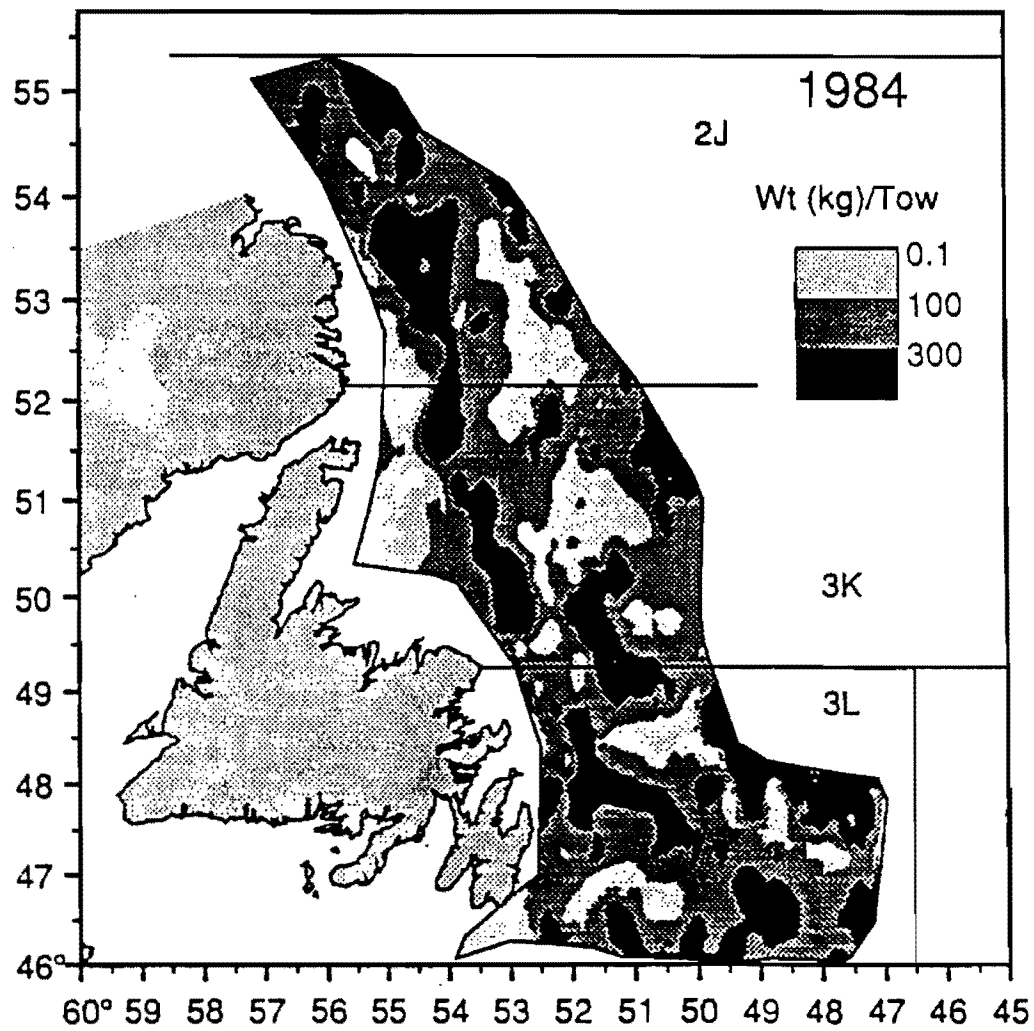

Figure 6: Continued.

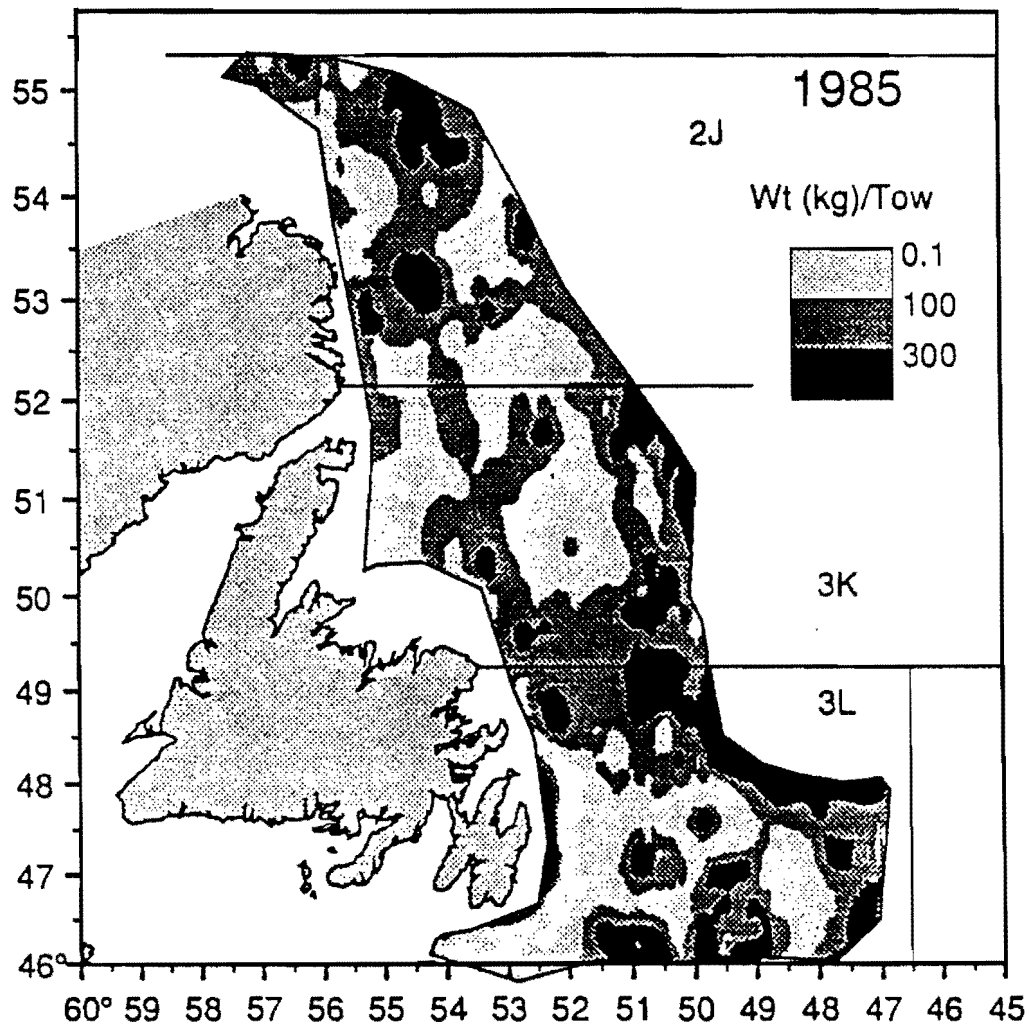

Figure 6: Continued.

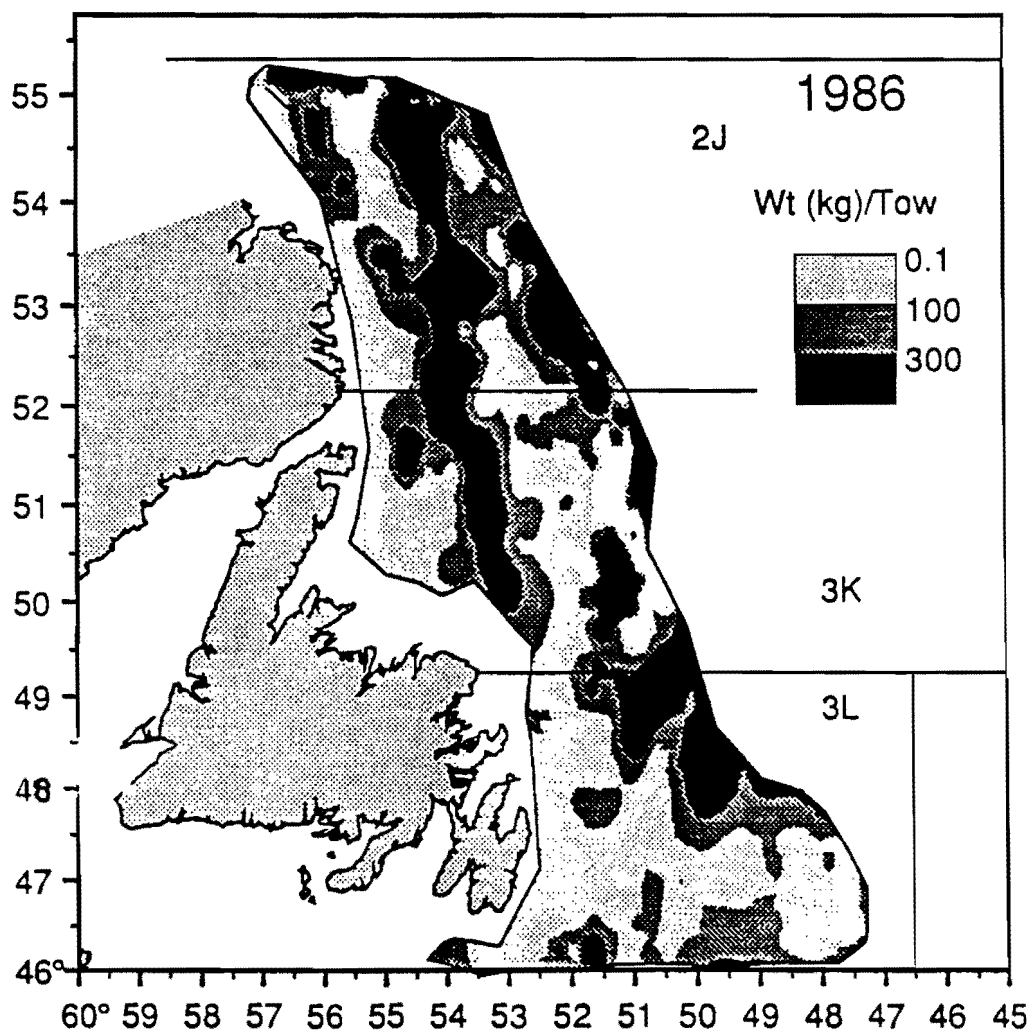

Figure 6: Continued.

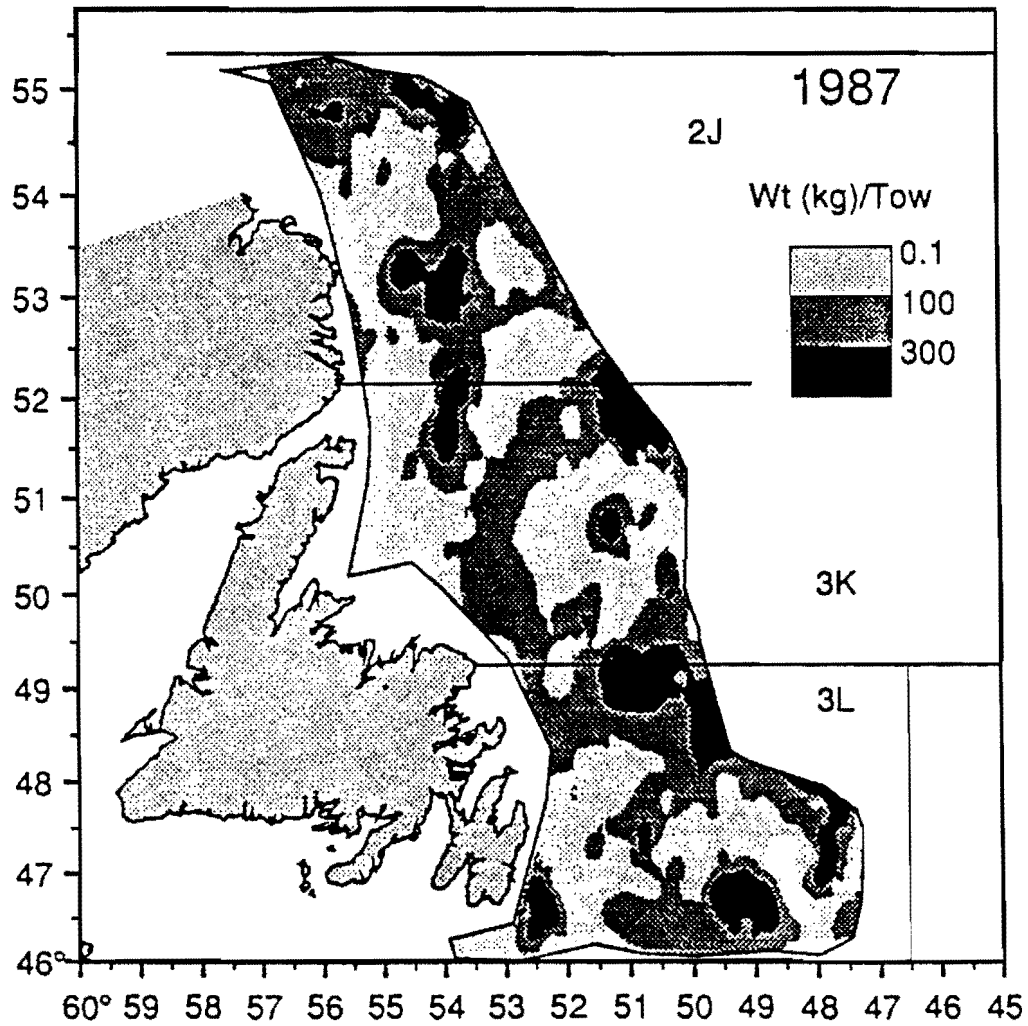

Figure 6: Continued.

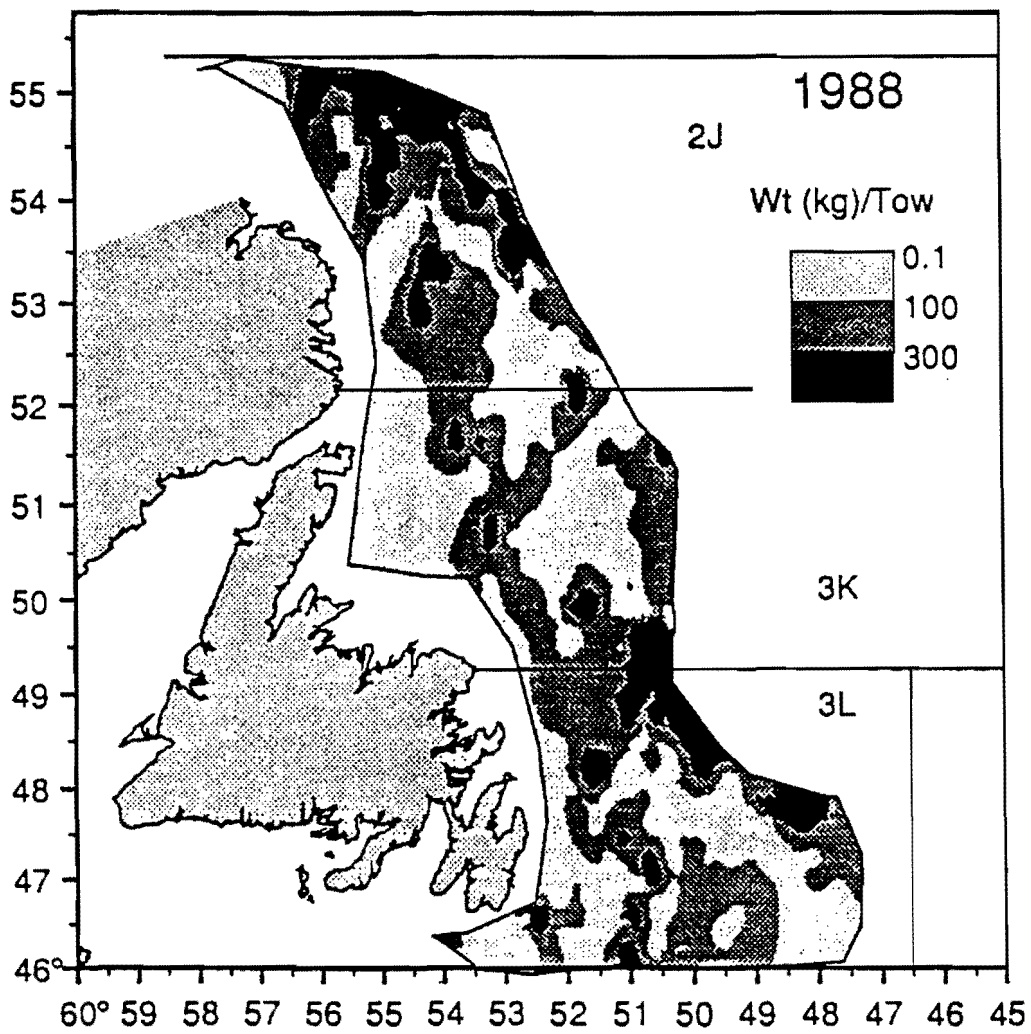

Figure 6: Continued.

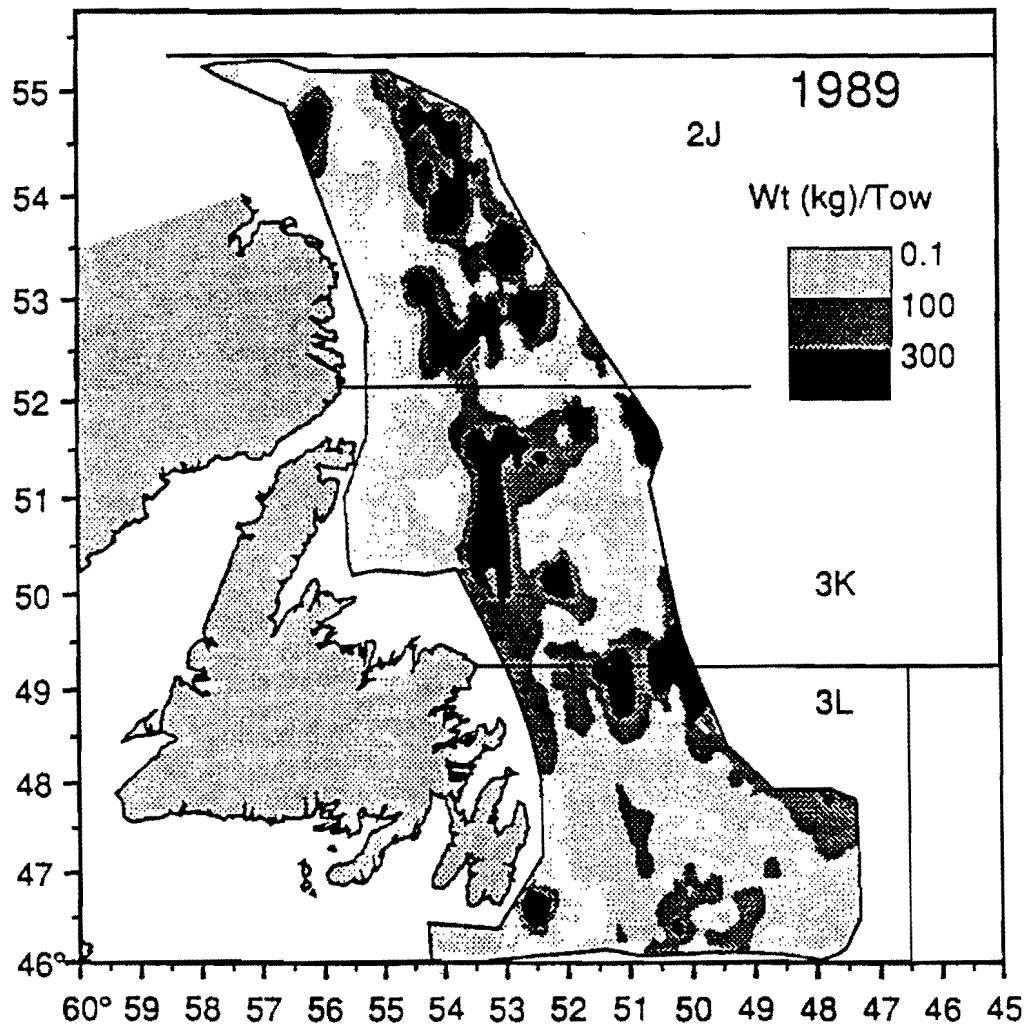

Figure 6: Continued.

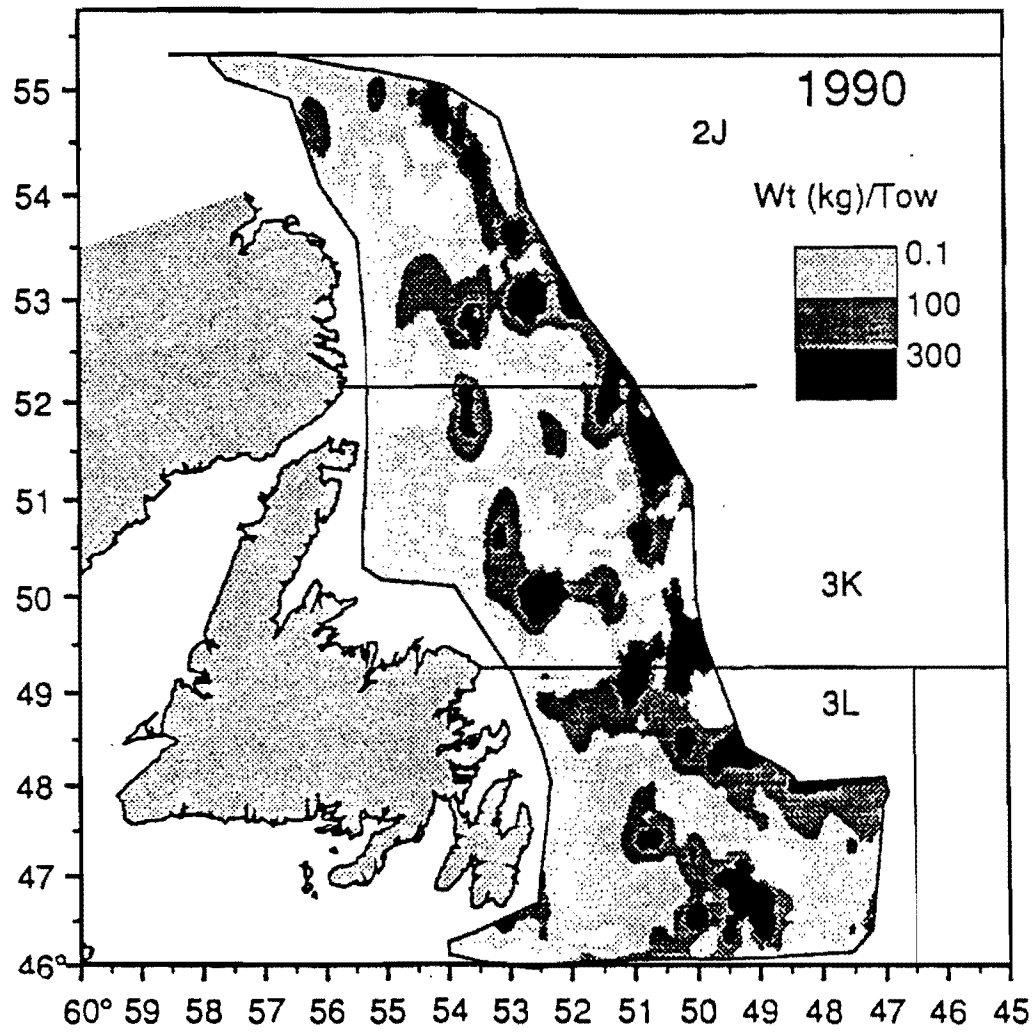

Figure 6: Continued.

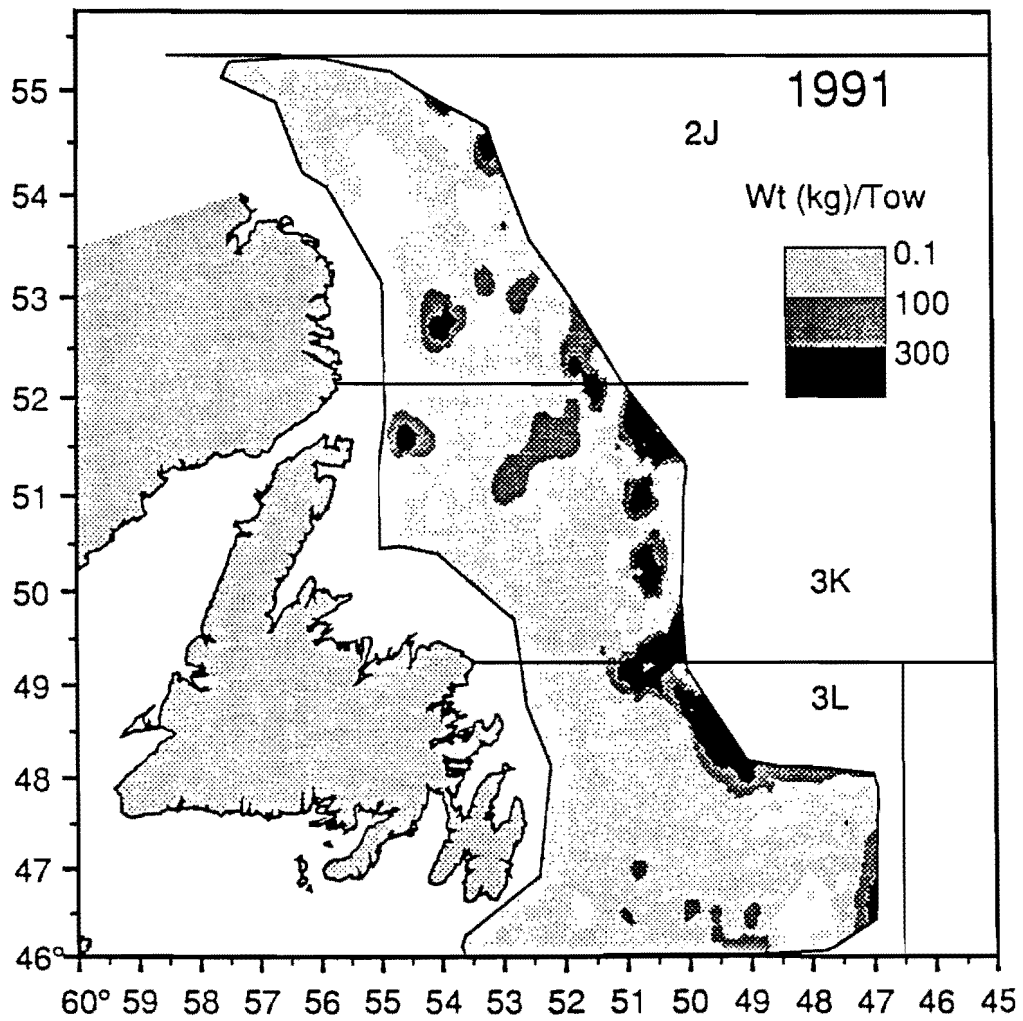

Figure 6 (continued).

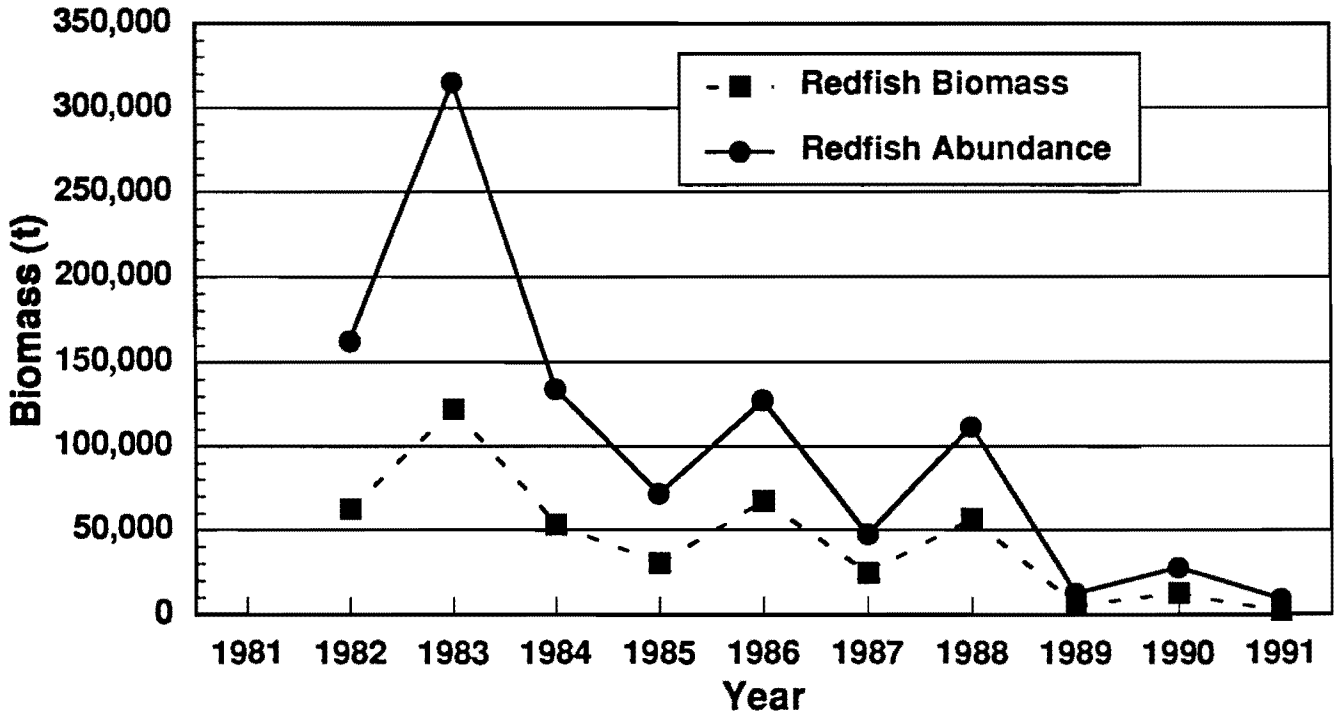
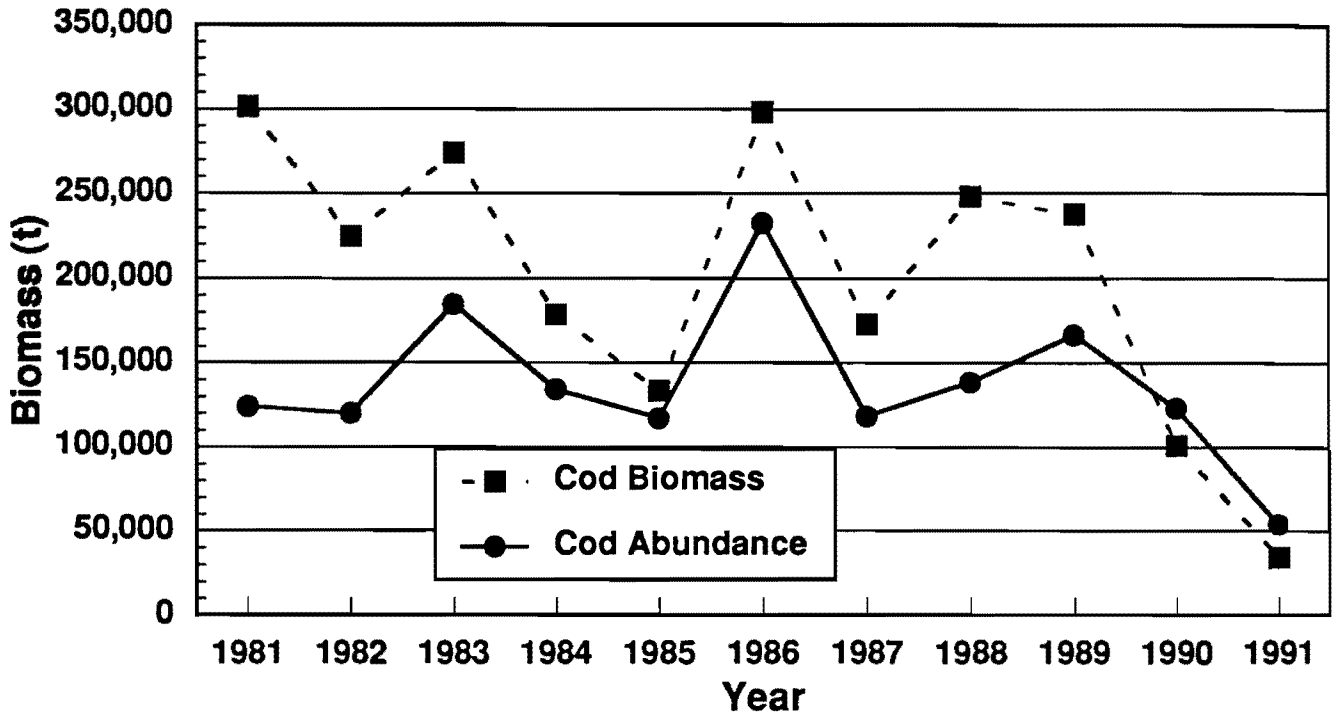

Figure 7: Comparison of trends in biomass and abundance in Div. 2J.

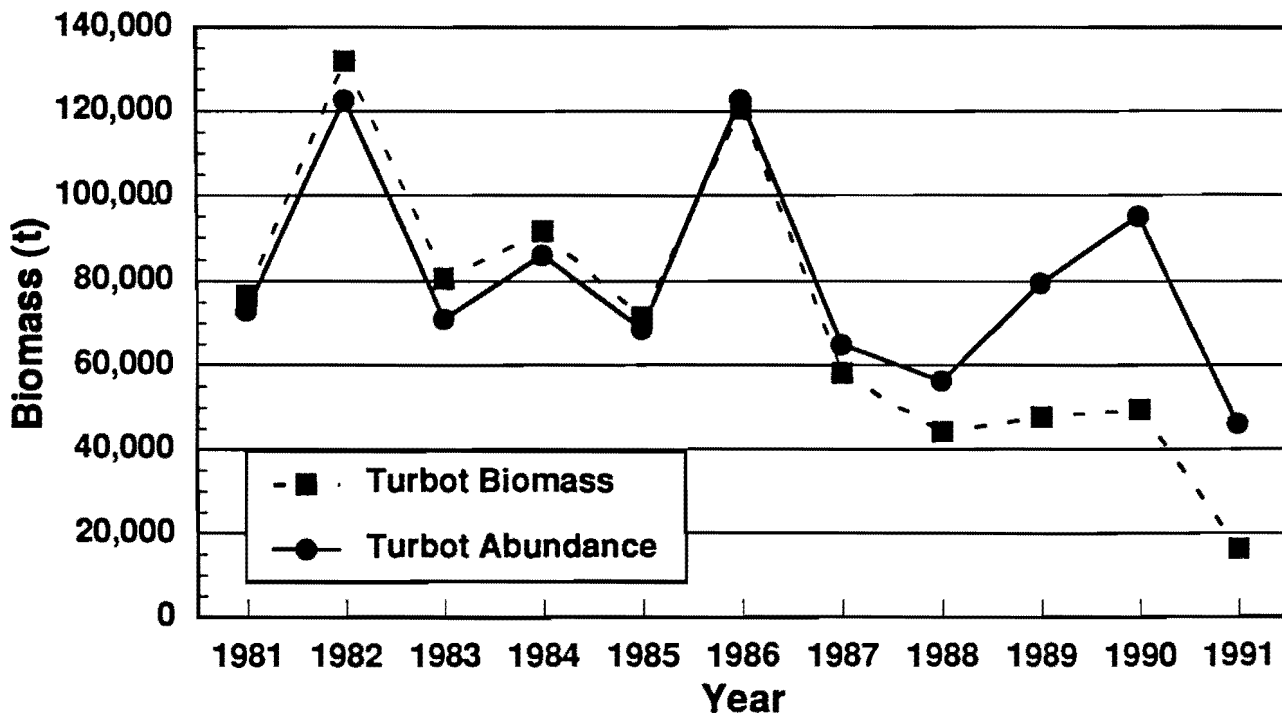
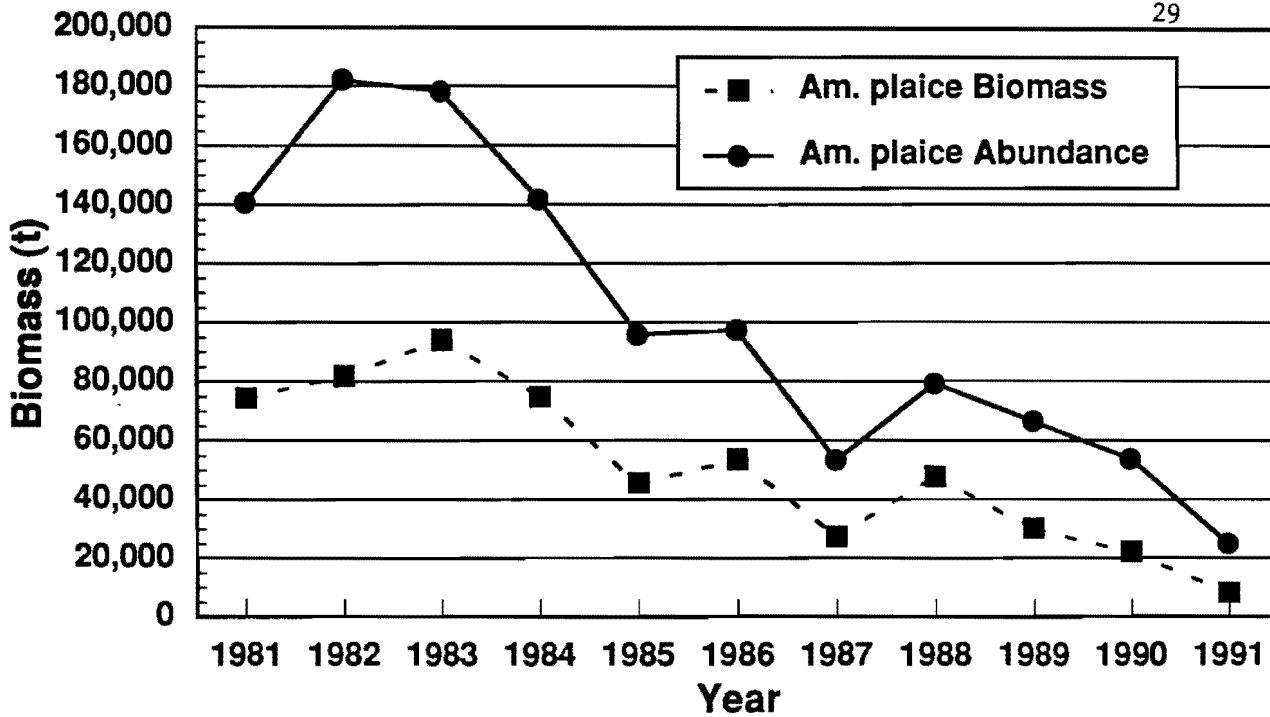

Figure 7: Continued.

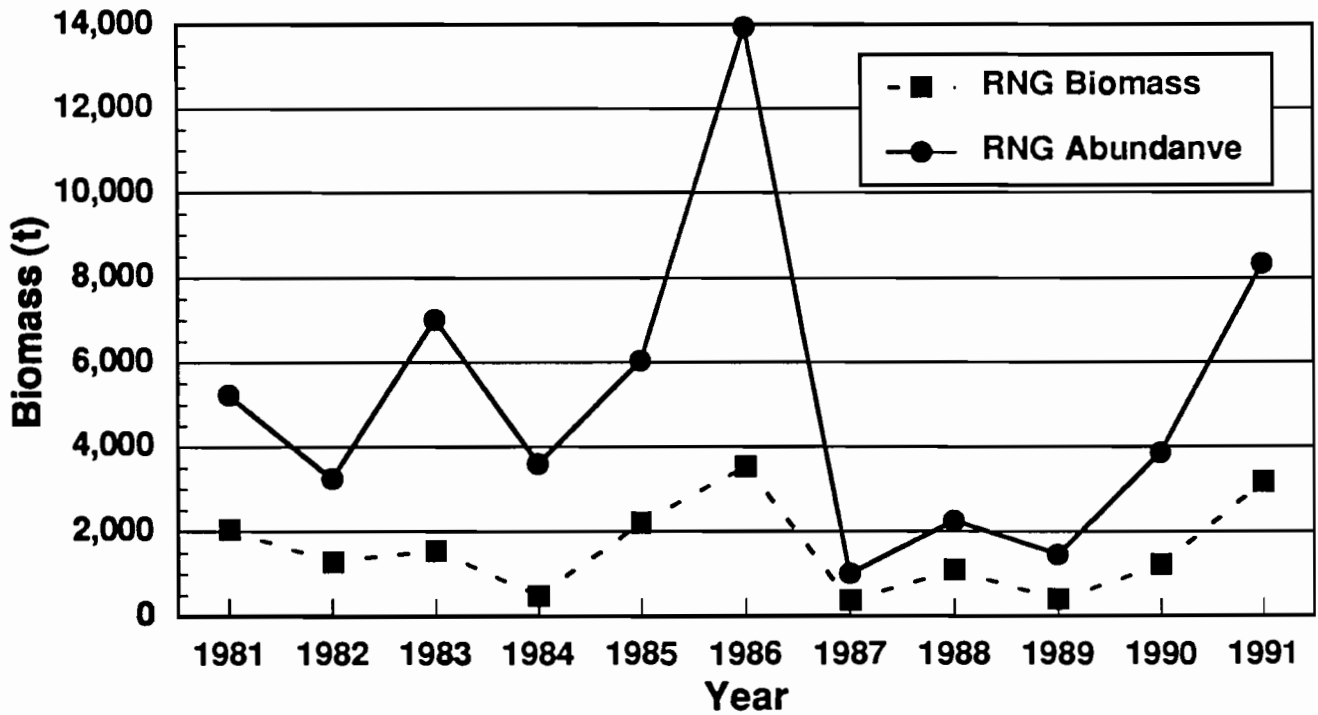
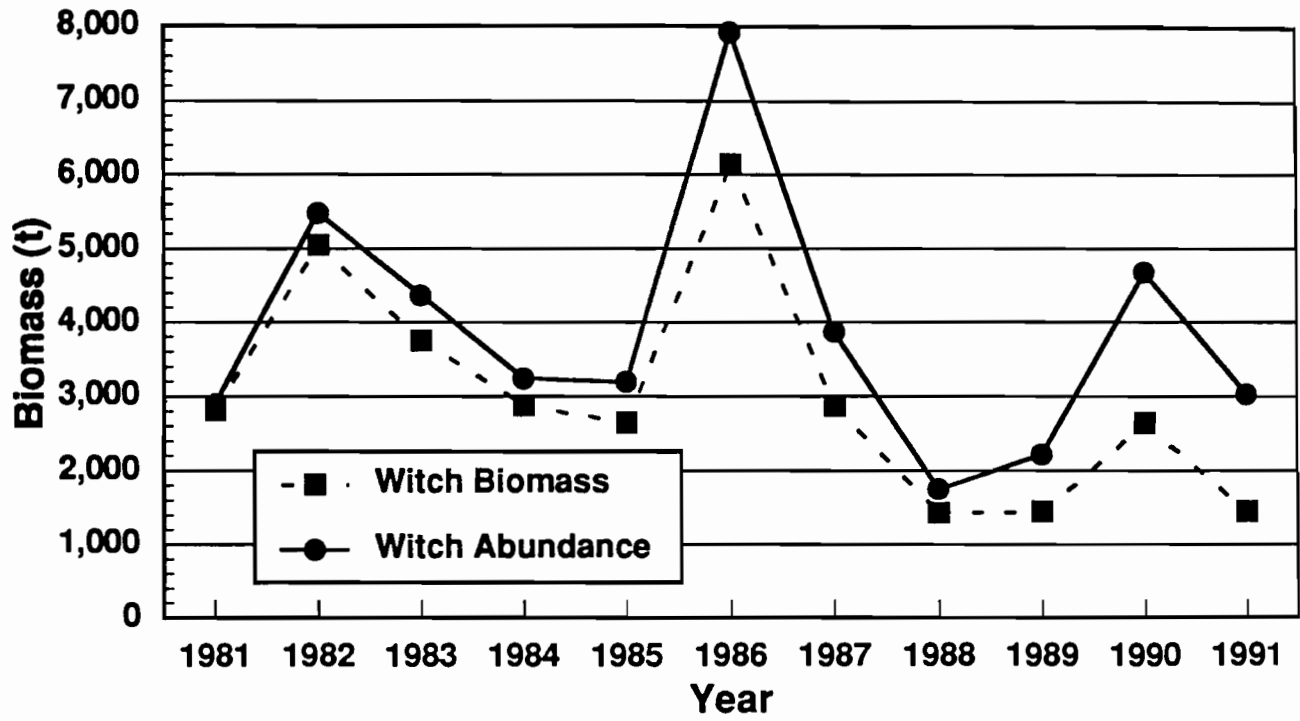

Figure 7: Continued.

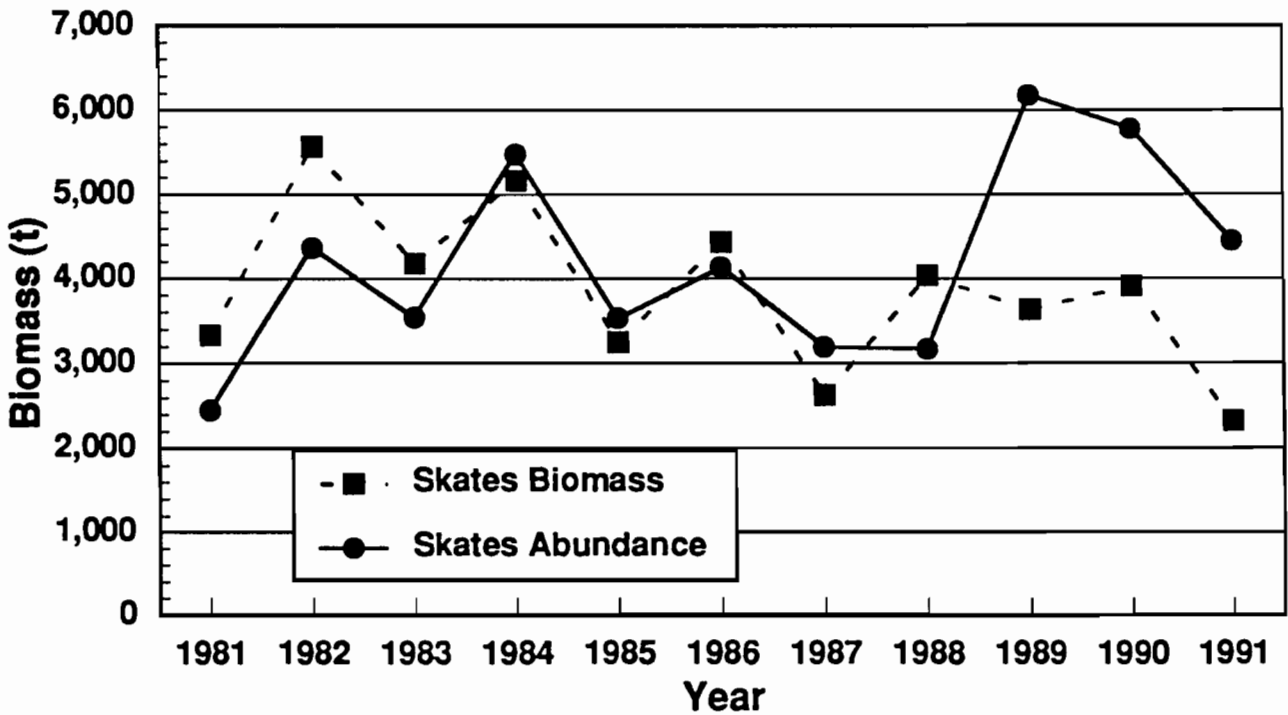
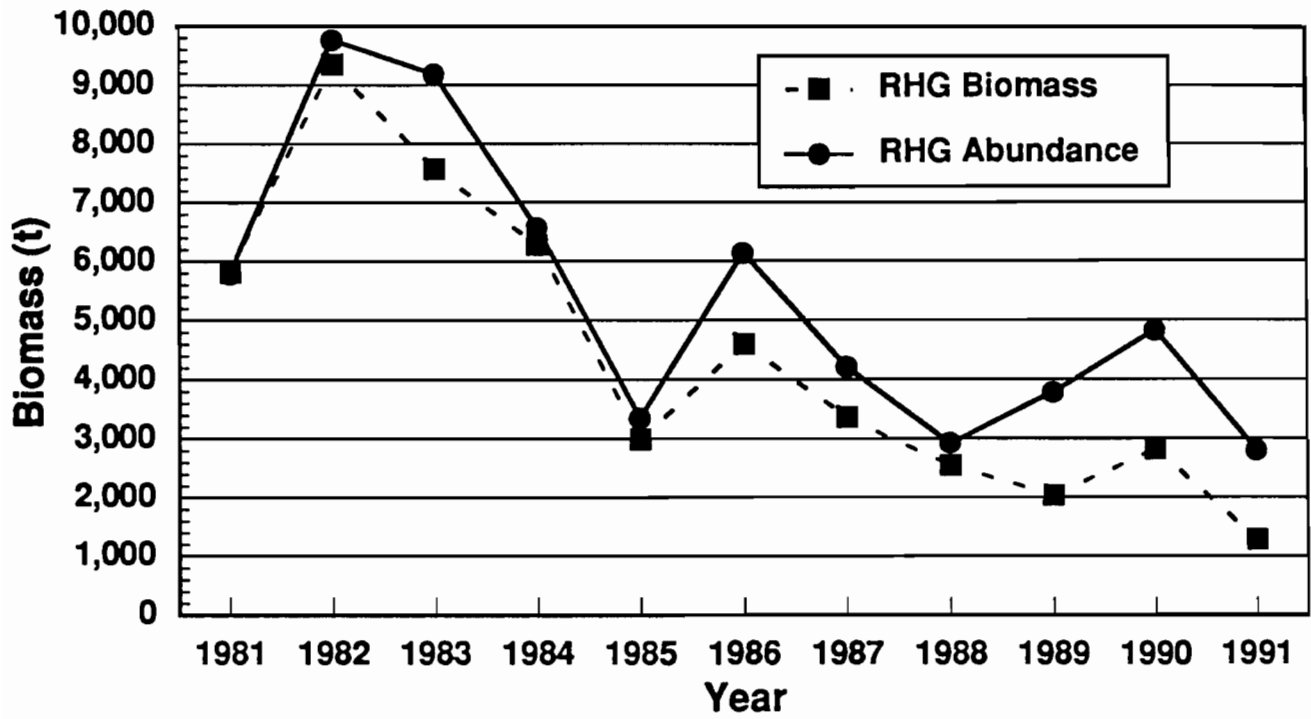

Figure 7: Continued.

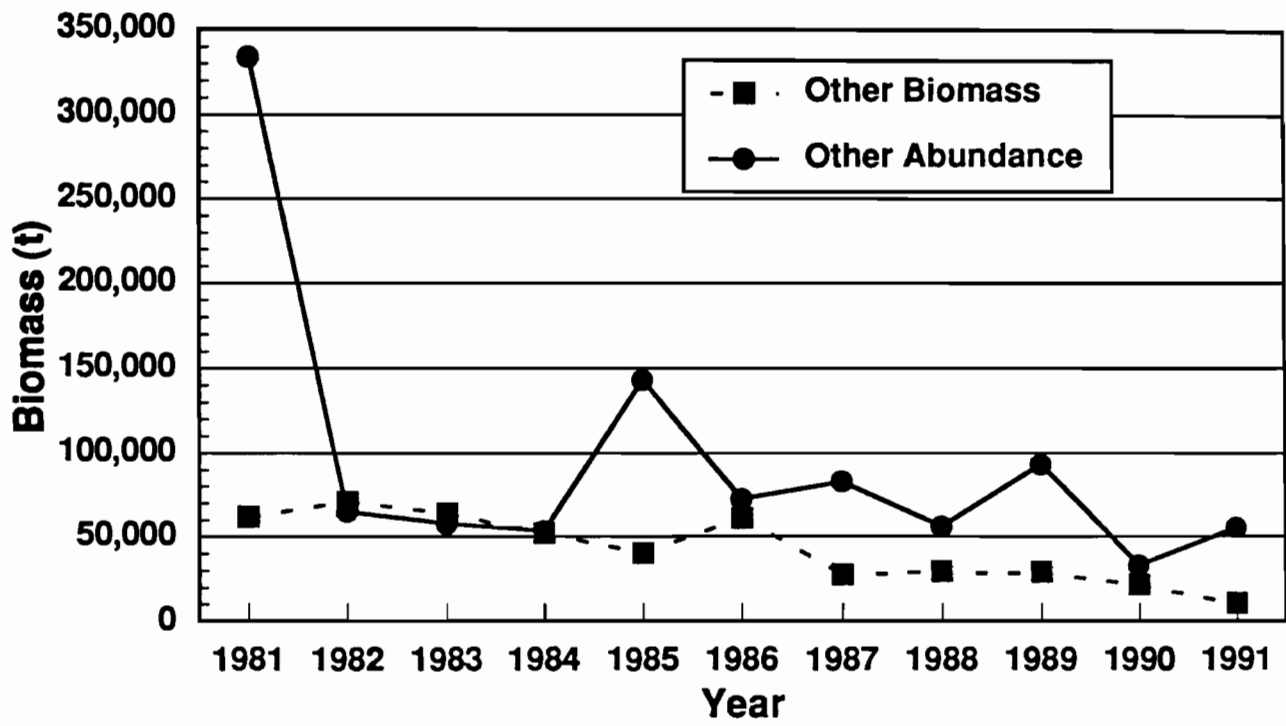

Figure 7: Continued.

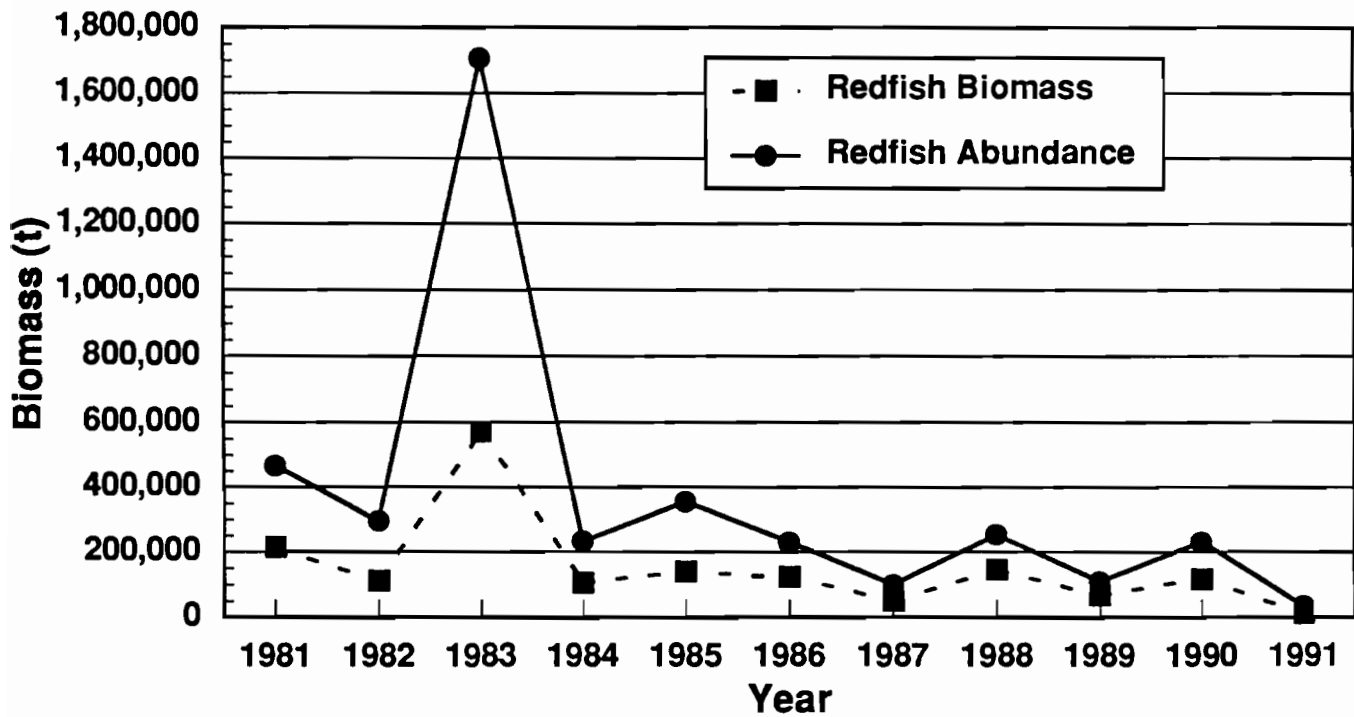
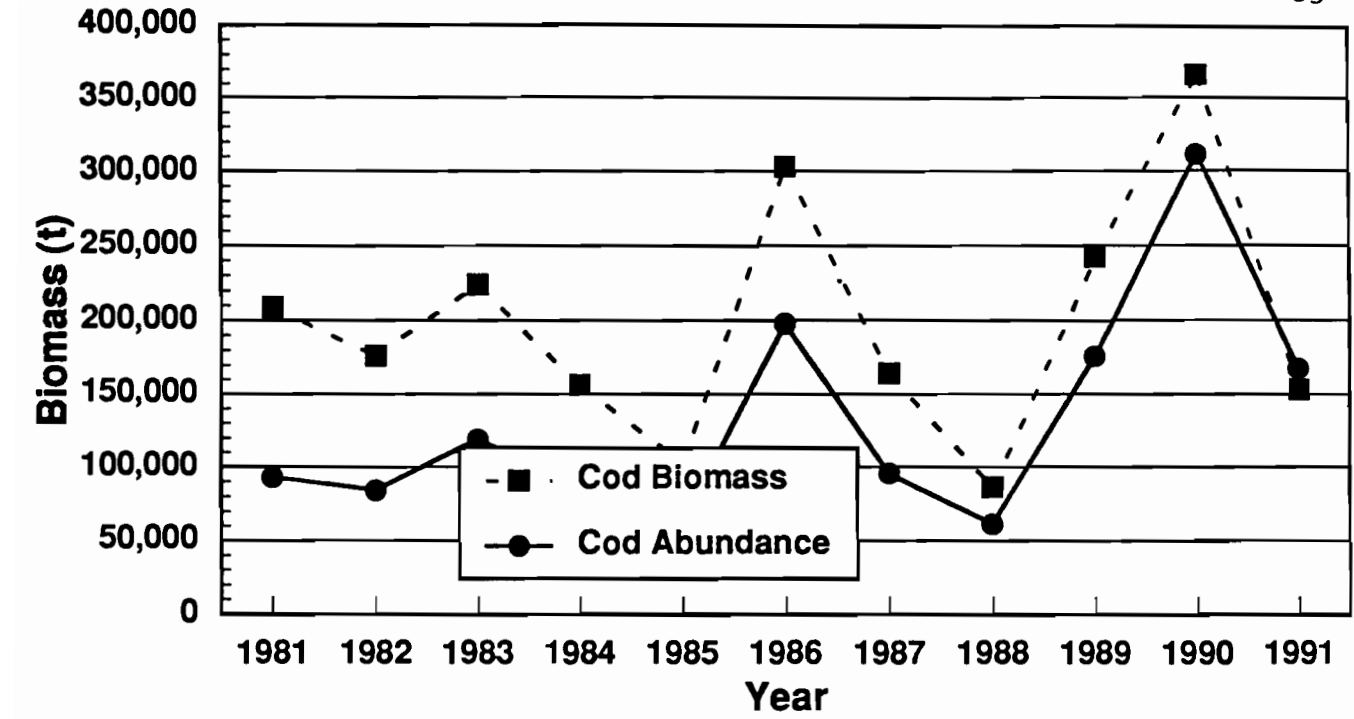

Figure 8: Comparison of trends in biomass and abundance in Div. 3K.

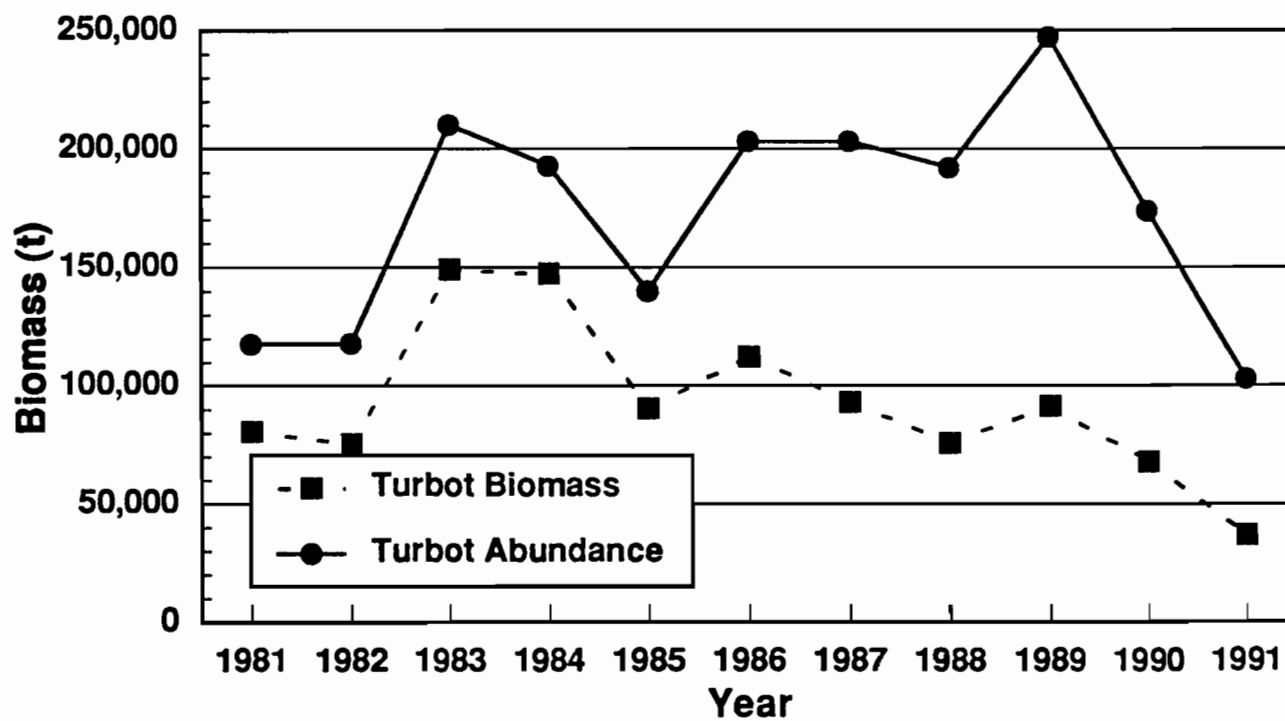
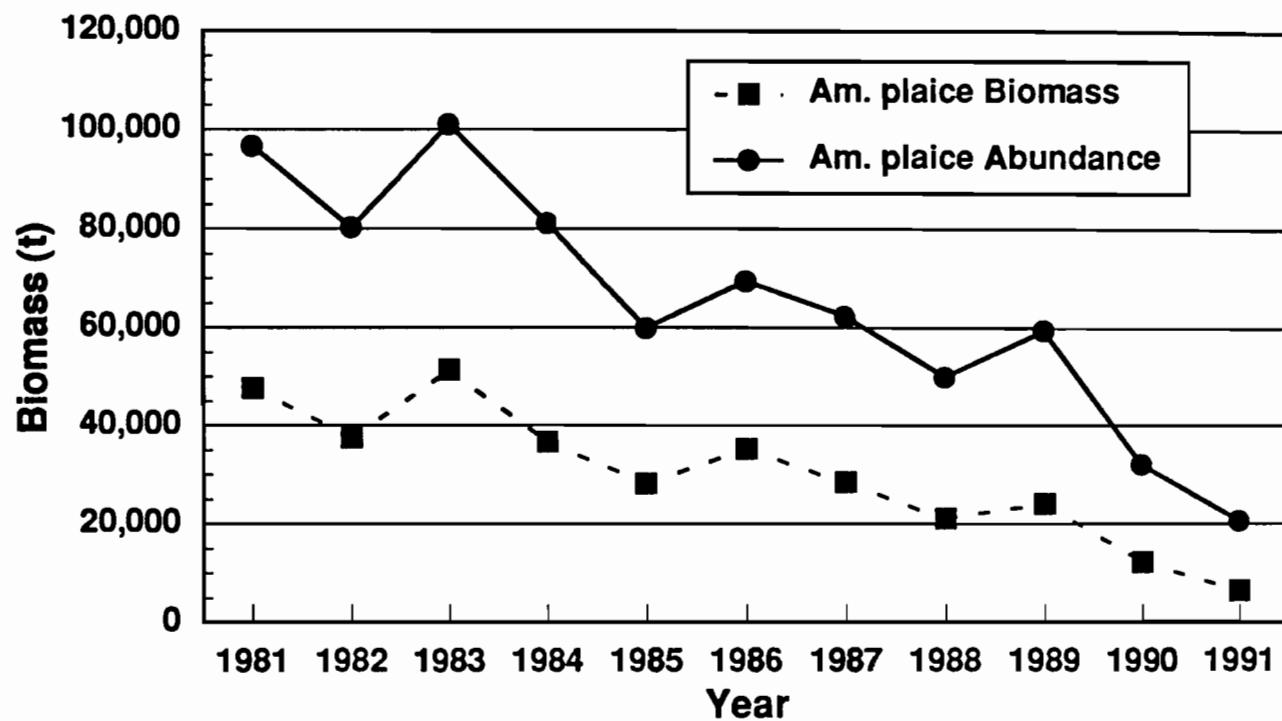

Figure 8: Continued.

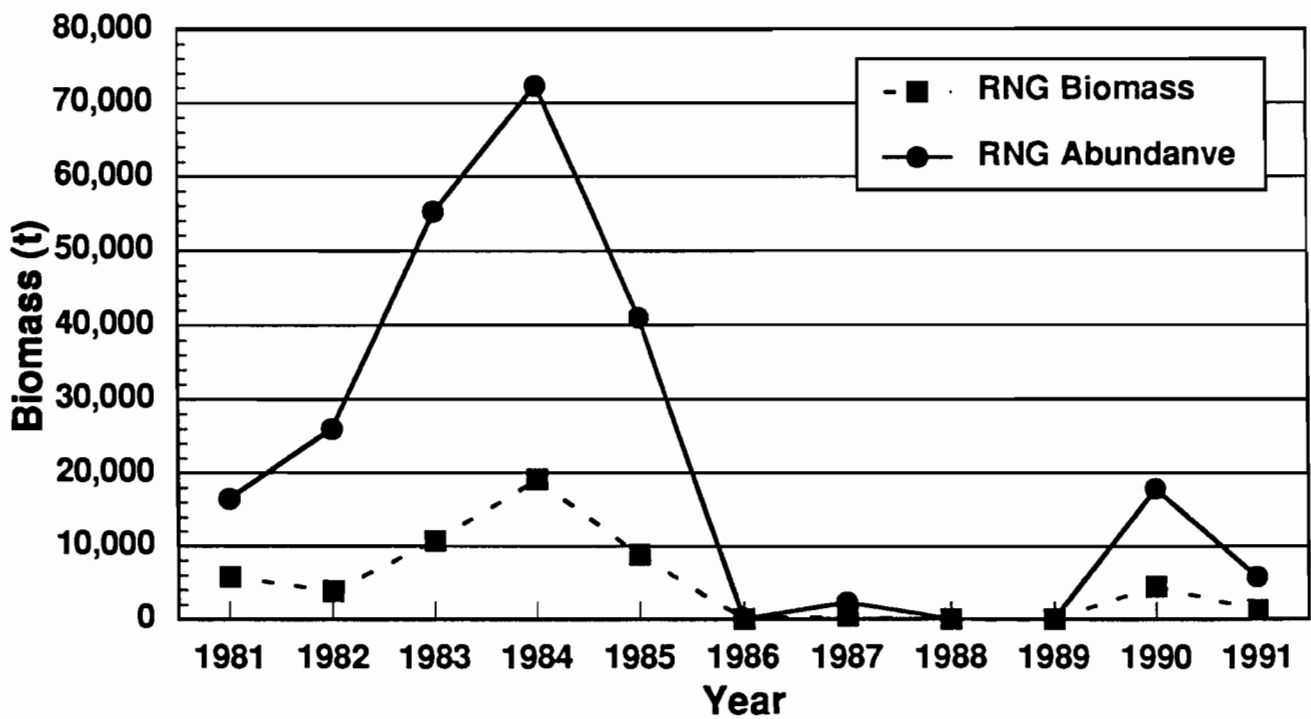
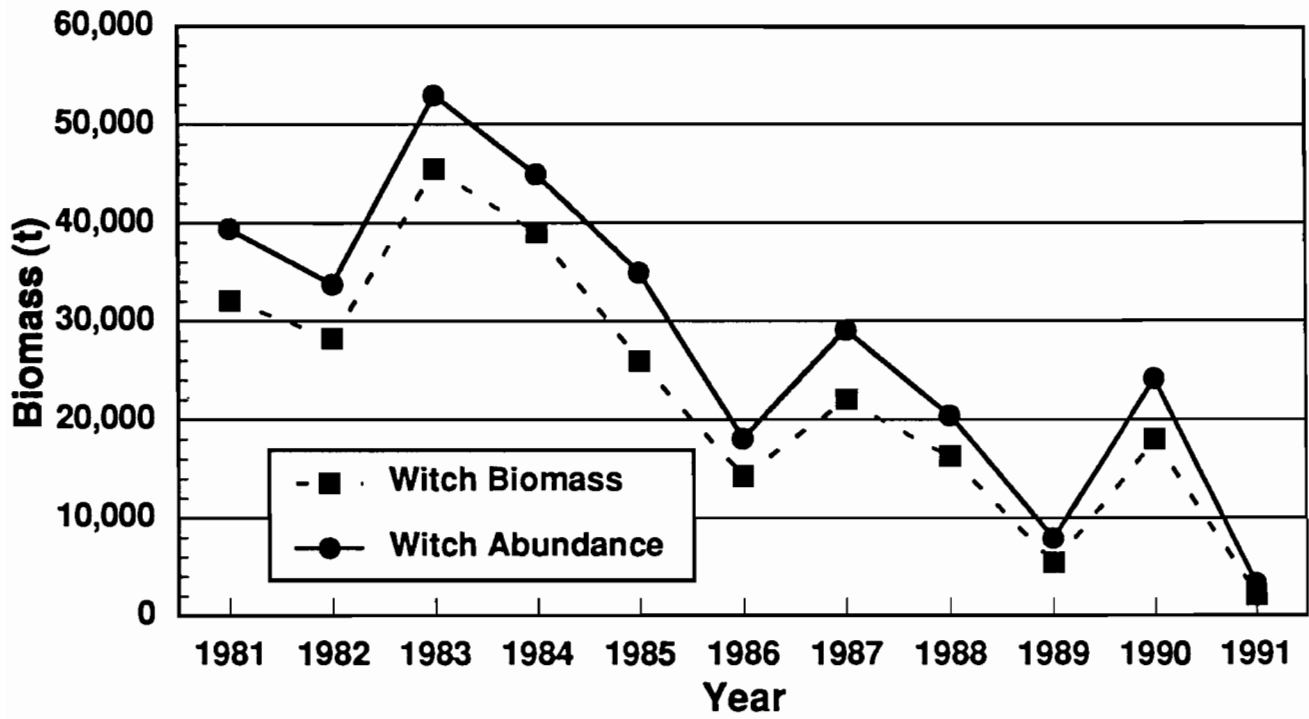

Figure 8: Continued.

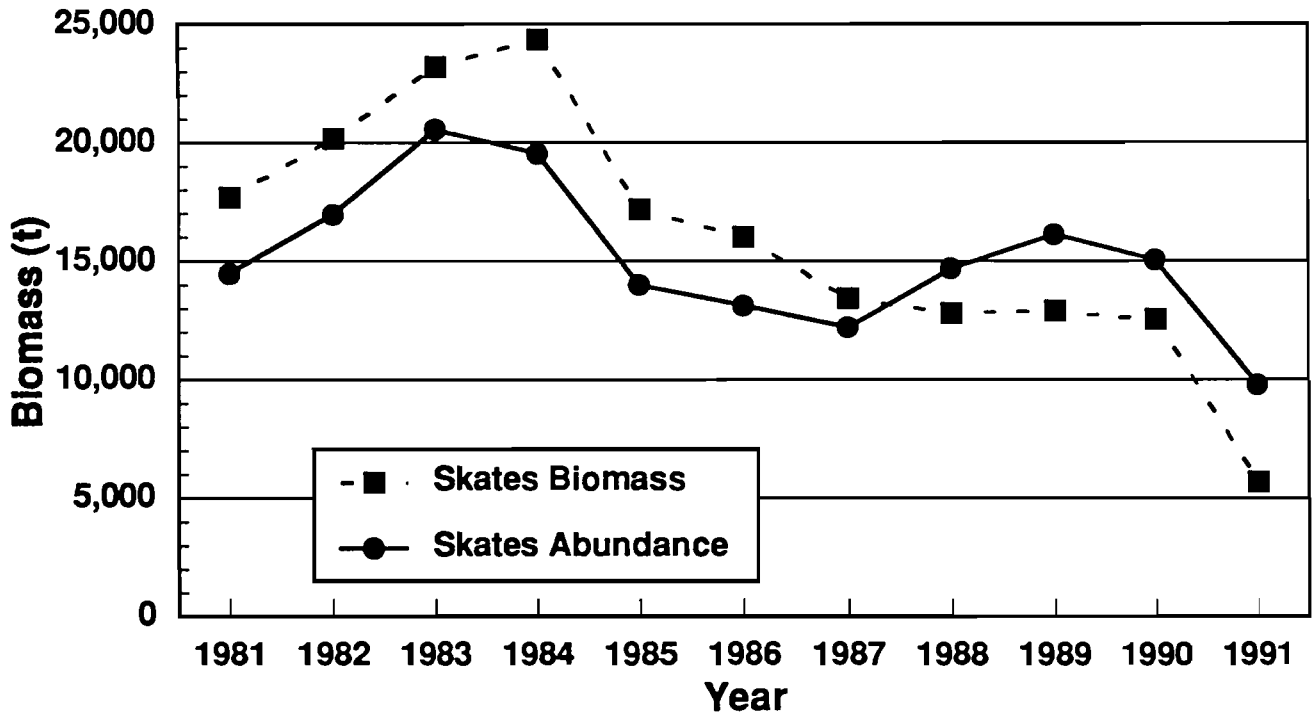
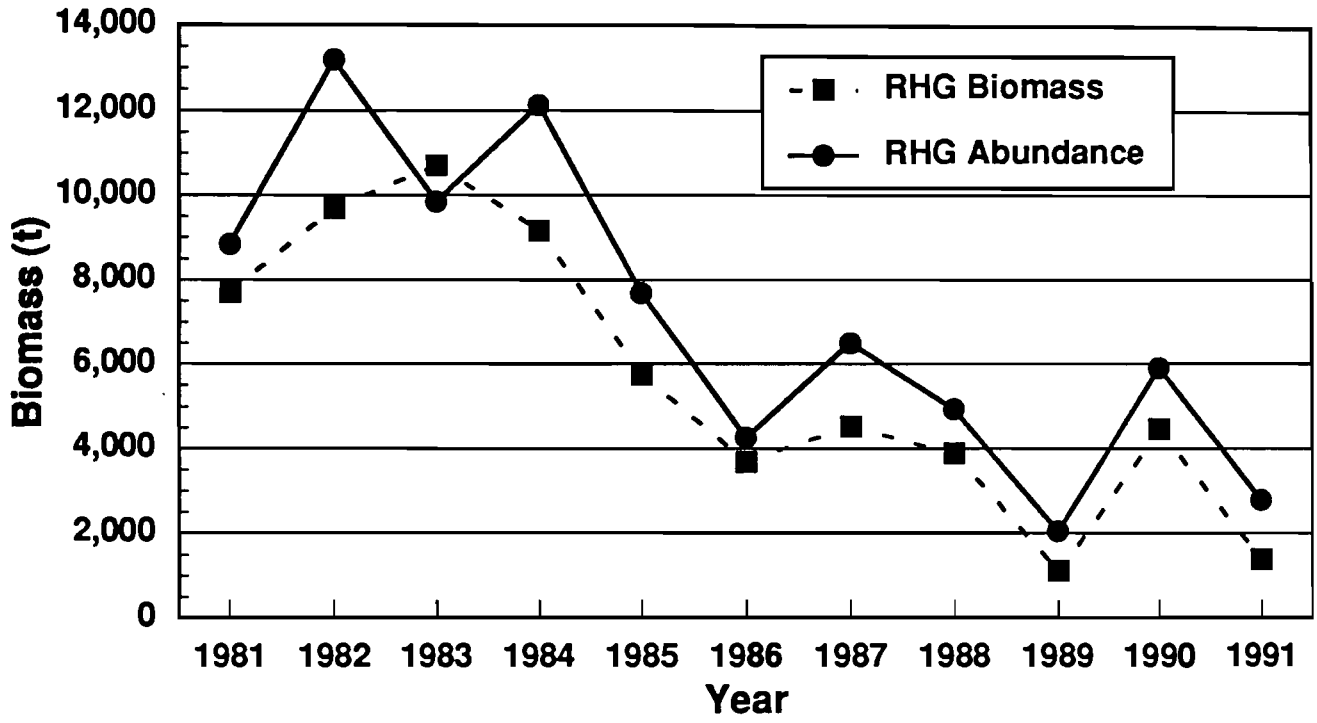

Figure 8: Continued.

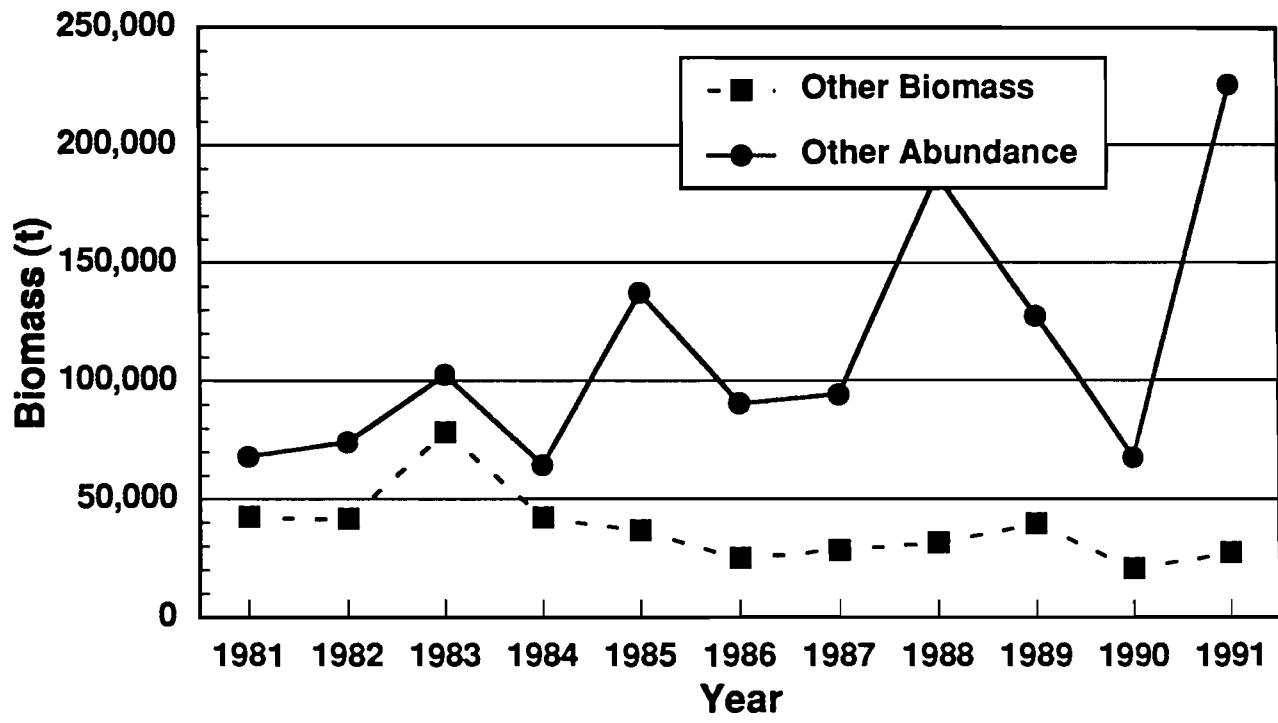

Figure 8: Continued.

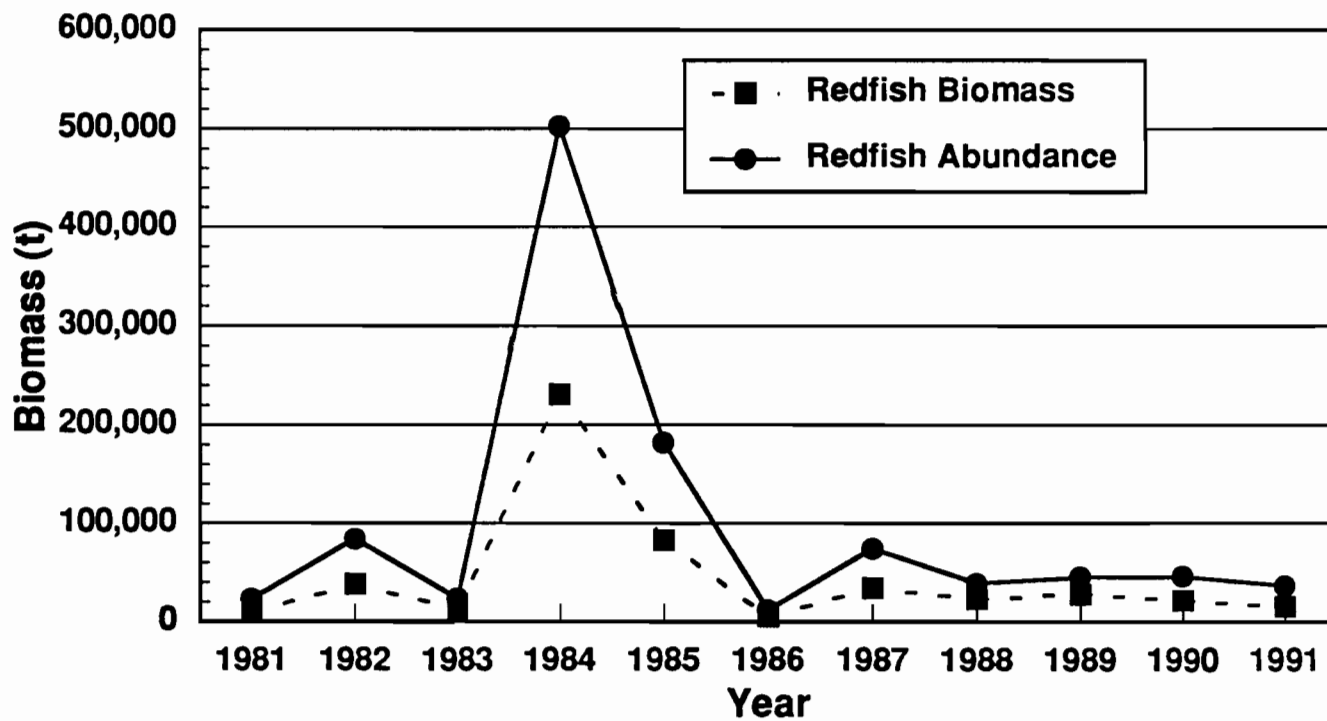
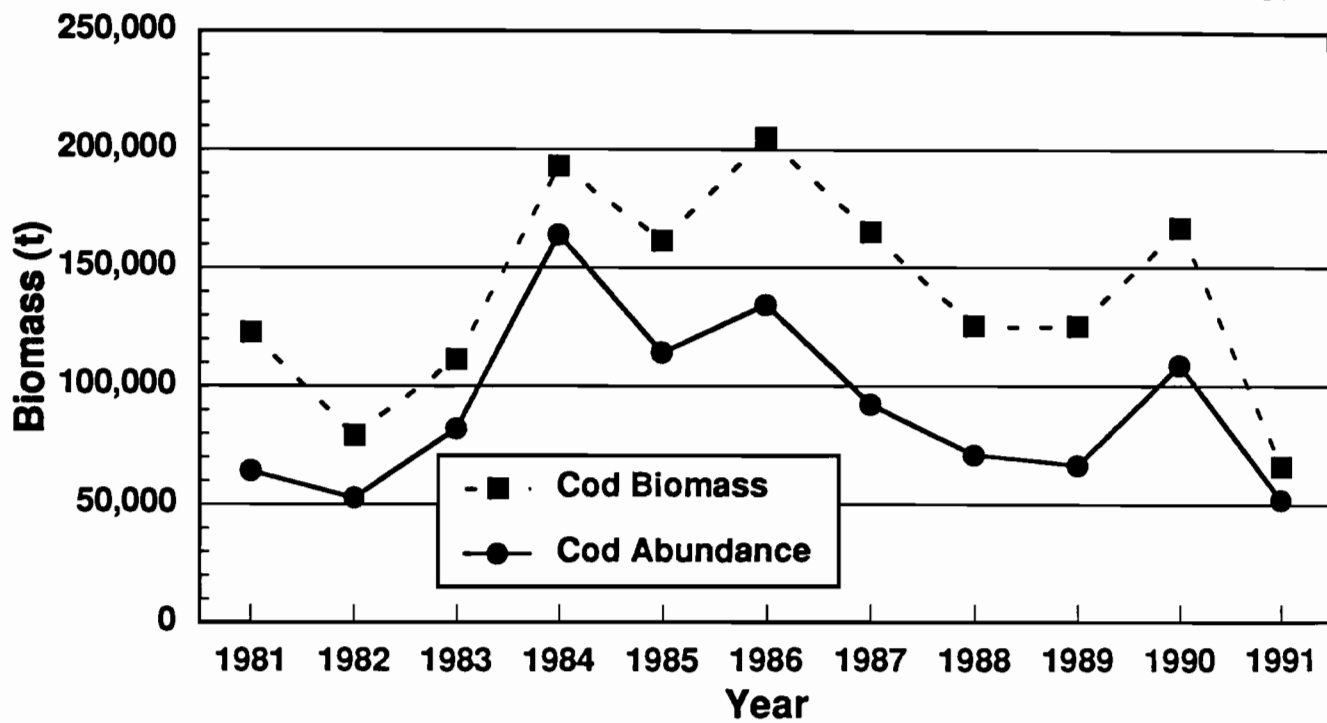

Figure 9: Comparison of trends in biomass and abundance in Div. 3L.

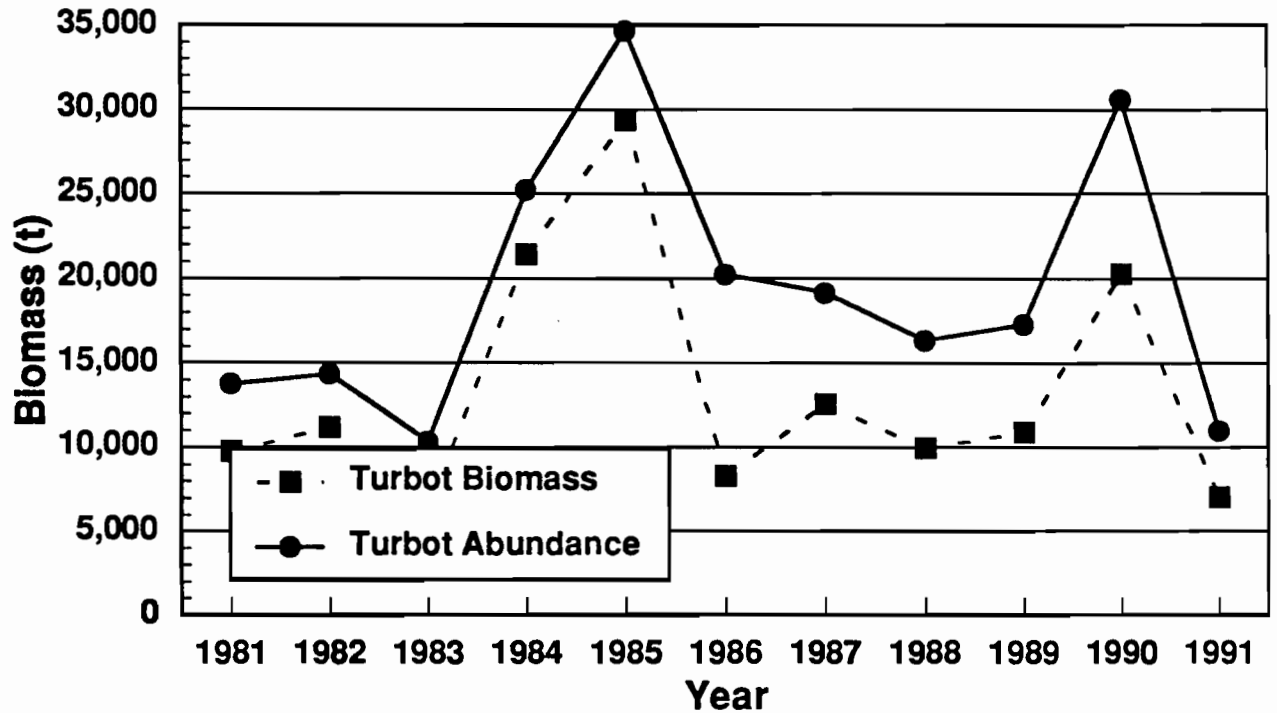
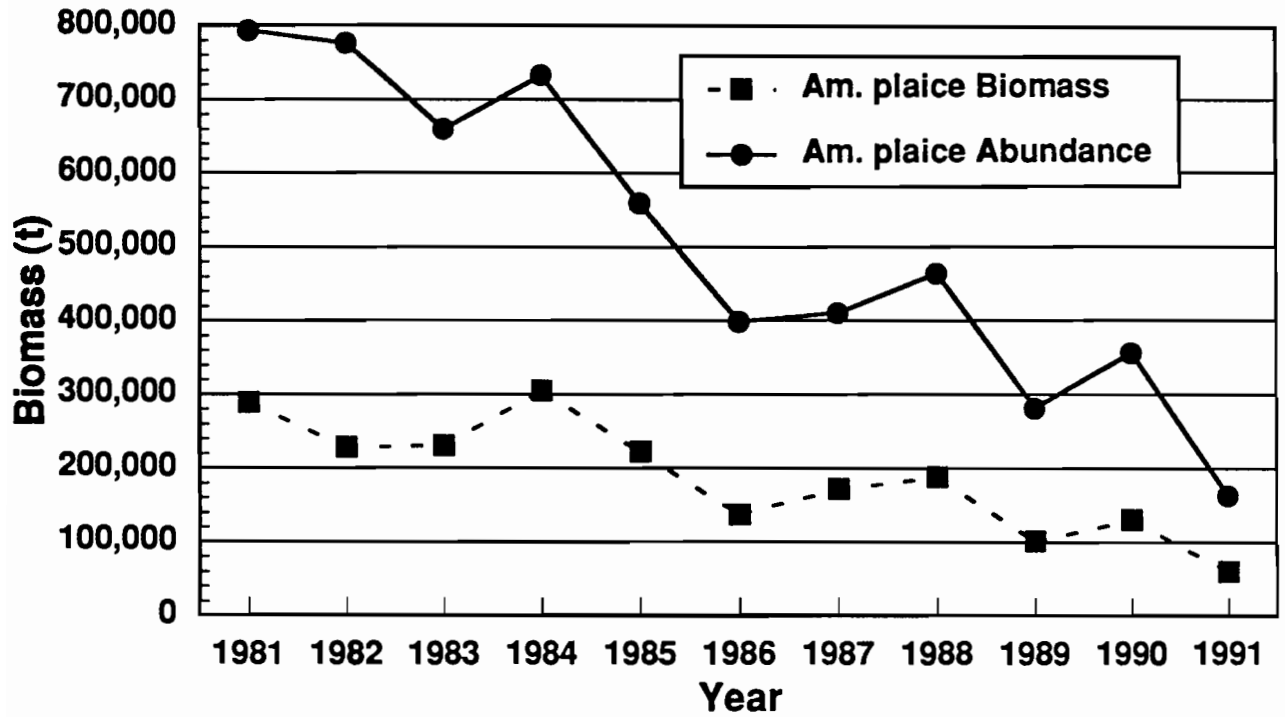

Figure 9: Continued.

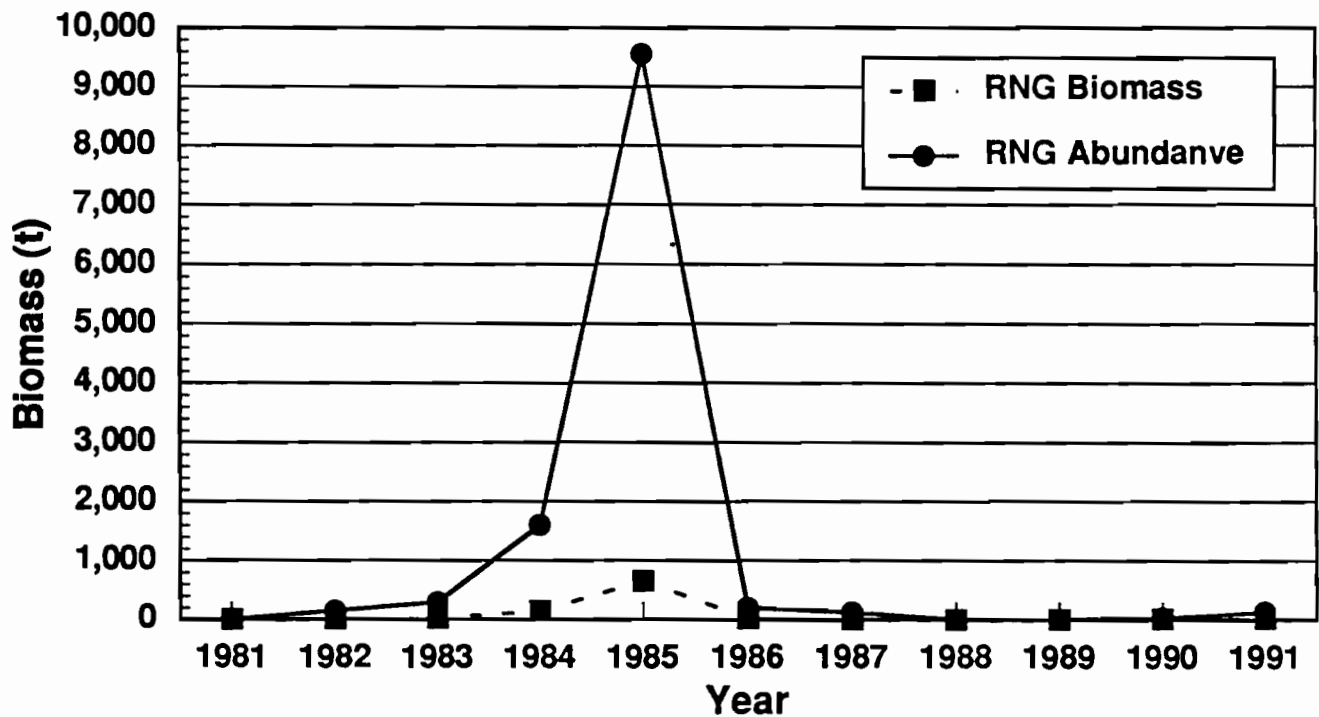
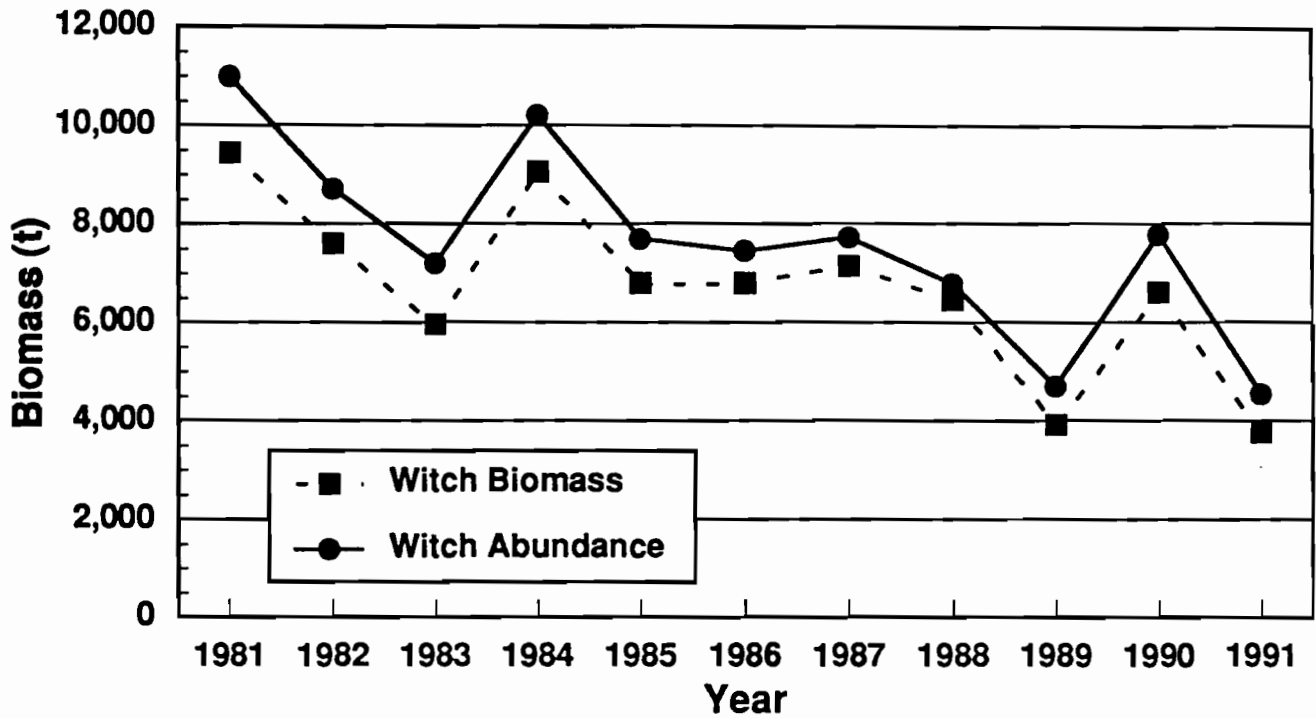

Figure 9: Continued.

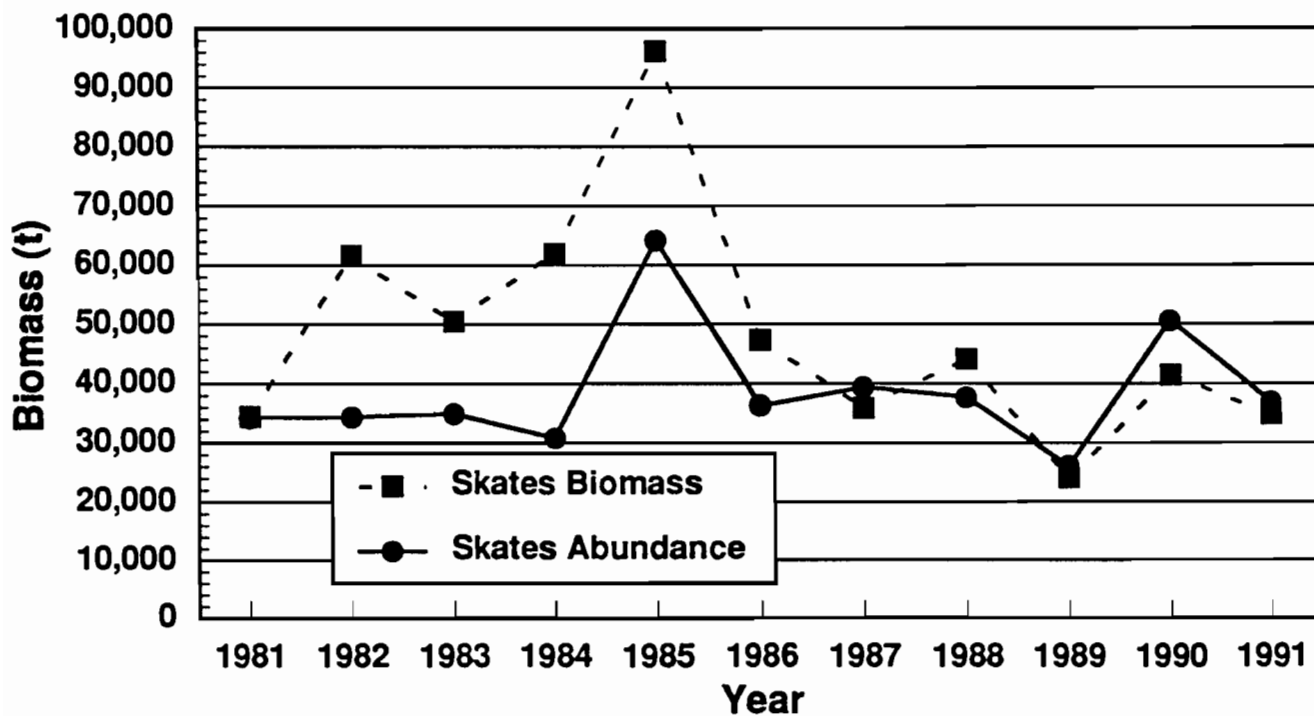
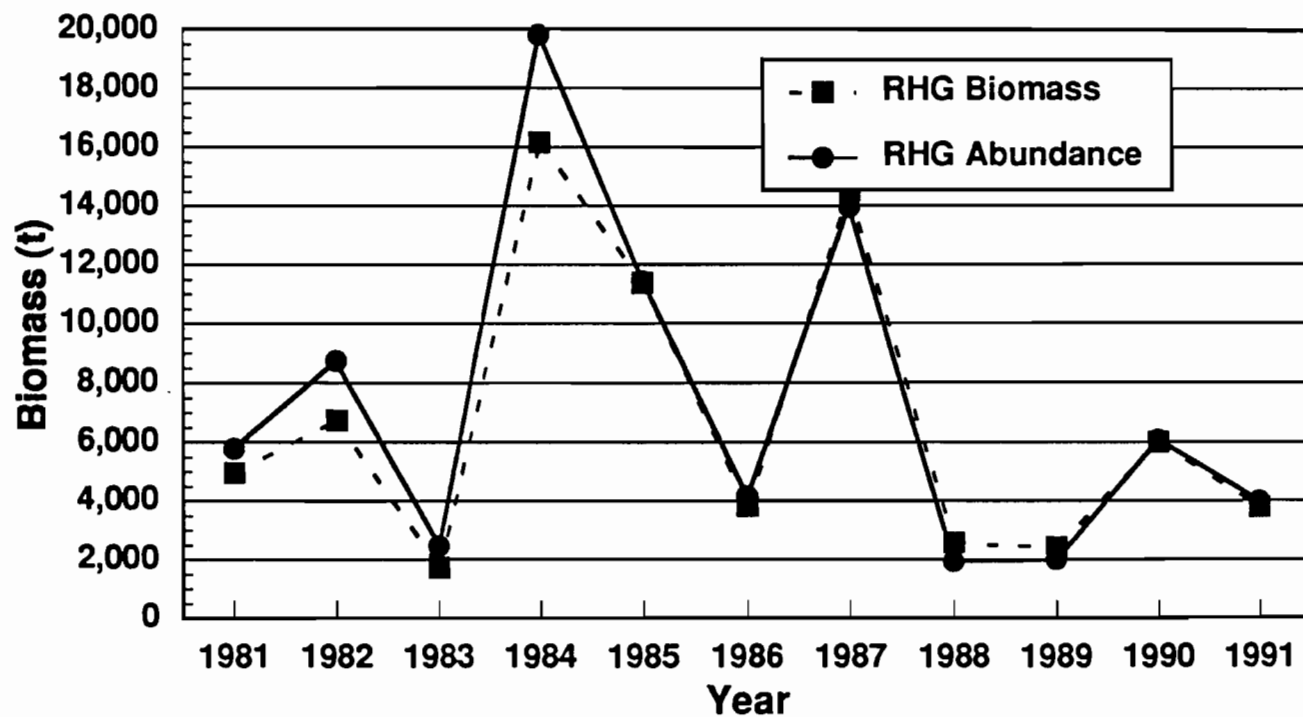

Figure 9: Continued.

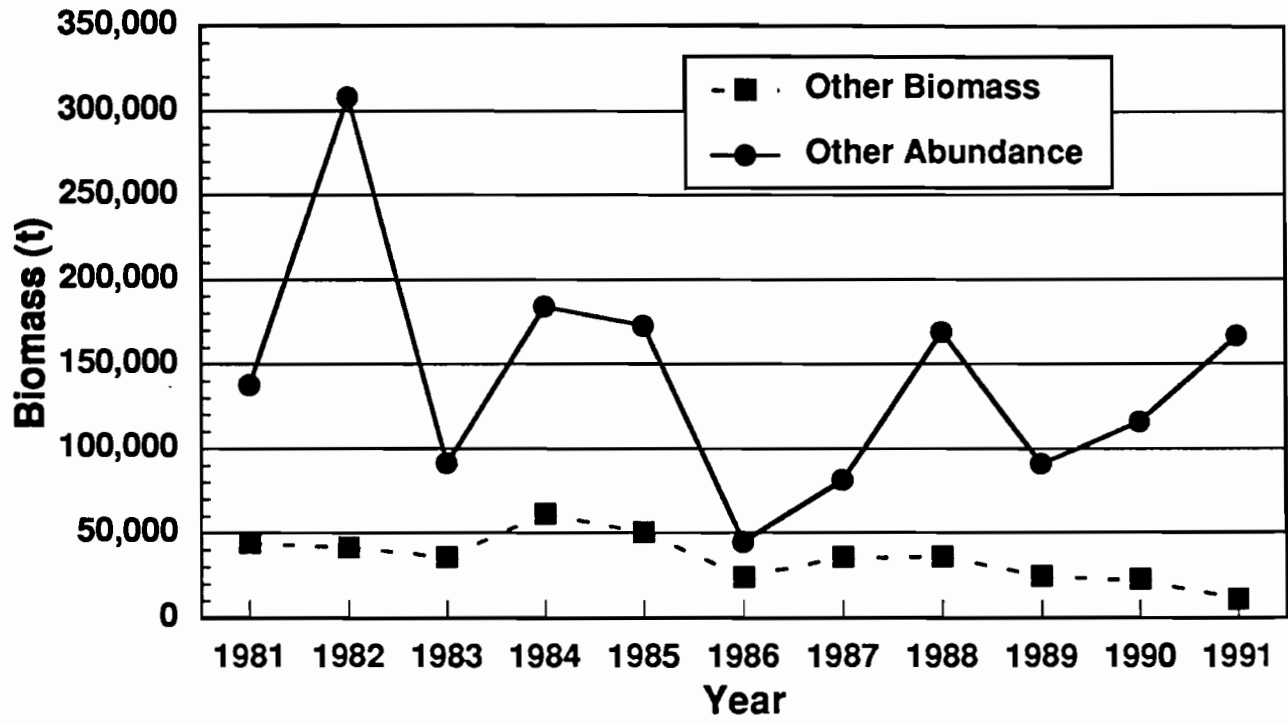

Figure 9: Continued.