

FISHERIES RESEARCH BOARD OF CANADA  
Pacific Oceanographic Group  
Nanaimo, B. C.

Circular 1962 - 1  
January 11, 1962.

Stilling Well Design for the Hecate Model Tide Gauges

I. Introduction

The Hecate Model (Fig. 1) is a hydraulic model of the region consisting of Dixon Entrance, Queen Charlotte Sound and Hecate Strait (Fig. 2). The model to prototype scales are:

horizontal - 1 foot = 4 nautical miles  
vertical - 1 inch = 25 feet  
time - 61.5 seconds = 1 solar day.

Tides are generated in the model by computer-controlled tilting plates (Fig. 3). Maximum tidal range in the prototype is 25 feet, equivalent to one inch in the model. The vertical displacement of the water is measured by electronic tide gauges (Fig. 4); and recorded on an 8-channel recorder.

The tide gauges are capable of a recorded resolution of 0.002 inches and have a time response of 0.5 seconds. This accuracy is often undesirable because of the presence of spurious ripples on the water surface. They are superimposed on the tidal oscillations and may make interpretation of the records difficult.

The ripples have much higher frequencies than do the tidal oscillations. Especially troublesome were some having periods of 1.5 and 3 seconds. Therefore, it was decided to develop a filter which could isolate the tide gauge sensing probe from the unwanted oscillations without greatly attenuating the effect of the tides. The device adopted consisted of a cylindrical well, housing the probe, with a small hole in the bottom to provide for the entry of water. The determination of optimum hole size was obtained with the aid of an analogue computer (Fig. 5).

II. Analysis of the problem

Derivation of the governing equation

The physical situation is illustrated in Fig. 6, where the stilling well diameter is  $D$  and inlet hole diameter is  $d$ . The height of tide in the well is  $\eta$  and outside the well is  $\epsilon$ . The bottom of the well is at a distance  $h$  below mean sea level.

Accelerations, which are relatively small in this case, can be neglected. Therefore, Bernoulli's equation can be applied between points in the flow entering the inlet hole and the flow at the free surface outside the well. (Bernoulli's equation cannot be applied directly between

points inside and outside of the well because of the sudden expansion through the inlet hole, with a consequent loss of energy). Assuming a homogeneous, incompressible fluid, we obtain

$$\frac{v_{\epsilon}^2}{2} + g\epsilon = \frac{v_d^2}{2} + g\eta \quad (1)$$

where  $v_{\epsilon}$  is the vertical velocity of the water surface outside the well,  $v_d$  is the velocity of flow at the inlet hole and  $g$  is the acceleration due to gravity.

From continuity

$$D^2 v_m = d^2 K_d v_d \quad (2)$$

where  $v_m$  is the vertical velocity of the water surface inside the well, and discharge coefficient  $K_d$  accounts for both contraction and friction factors of the flow through the inlet hole. Since  $v_{\epsilon}$  and  $v_m$  are approximately equal, it is seen that  $v_d$  exceeds  $v_{\epsilon}$  by, nearly, the ratio of the squares of the two diameters involved. Therefore, the  $v_{\epsilon}^2$  term can be dropped from equation 1 provided  $d \ll D$ . Then, combining the first two equations:

$$v_m = K_d \frac{d^2}{D^2} [2g(\epsilon - \eta)]^{\frac{1}{2}} \quad (3)$$

for flow into the hole. To account for flow in both directions through the hole, equation 3 must be modified slightly to

$$v_m = [\text{sign}(\epsilon - \eta)] \cdot K_d \frac{d^2}{D^2} [2g |\epsilon - \eta|]^{\frac{1}{2}} \quad (4)$$

This is the equation governing stilling well response.

#### Parametric dependence of the governing equation

The equation for  $v_m$  is dependent on the parameters  $K_d$  and  $d$ . To determine the relationship of these parameters and the value of  $K_d$ , the following experiment was undertaken.

Stilling wells of diameter  $D = 2.835$  inches were fitted with holes varying in size from 1/16 inch to 1/2 inch. Each well was attached to a tide gauge and the gauge output connected to a recorder. The holes were stoppered and the gauges put in undisturbed water so that the dimension  $h$ , in Fig. 6 was approximately one inch. The stoppers were removed and records obtained of the rise of water in the wells as a function of time. These records are duplicated in Fig. 7.

Since the water surface did not have a tidal oscillation impressed on

it,  $\epsilon = 0$ . Also, at  $t=0$ ,  $\eta = -h$ . Equation 3 may then be rewritten as

$$\int_{-h}^{\eta} \frac{d\eta}{\sqrt{-\eta}} = K_d \frac{d^2}{D^2} \sqrt{2g} \int_0^t dt \quad (5)$$

Integrating:

$$\sqrt{-\eta} - \sqrt{h} = \frac{K_d}{2} \frac{d^2}{D^2} \sqrt{2g} t \quad (6)$$

This is the equation of a straight line. Thus, plotting  $\sqrt{-\eta}$  against  $td^2$  should yield a straight line with a slope of

$$m = \frac{K_d \sqrt{2g}}{2 D^2} \quad (7)$$

Such a plot is shown, for various hole sizes, in Fig. 8. It is seen that, within the limits of experimental error and for the values of  $d$  used, there is no dependence of  $m$  on  $d$ . From the straight line fitted by the least mean squares method, we obtain

$$K_d = 0.768$$

Thus, only a one parameter variation exists, namely the hole size  $d$ .

#### Determination of optimum hole size

Oscillations in the model basin consist of the primary tide with superimposed undesirable ripples. This situation can be represented mathematically by setting

$$\epsilon = A \sin \omega_A t + B \sin \omega_B t \quad (8)$$

where  $A$  is the amplitude of the primary tide and  $\omega_A$  is its frequency, and  $B$  and  $\omega_B$  are corresponding quantities for the ripples. Equation 4 now becomes

$$\frac{d\eta}{dt} = [\text{sign}(\epsilon - \eta)] K_d \frac{d^2}{D^2} [2g |A \sin \omega_A t + B \sin \omega_B t - \eta|]^{\frac{1}{2}} \quad (9)$$

This is a non-linear equation whose solutions are best examined with the aid of an electronic analog computer. The parameter  $d$  is then easily varied and the response  $\eta$  of the stilling well can be obtained for the different oscillations.

### III. Solution of the governing equation

#### Analogue computer setup

Equation 9 can be written in a more convenient form by letting

$$\begin{aligned}\alpha &= A \sin \omega_A t \\ \beta &= B \sin \omega_B t \\ K &= \frac{K_d \sqrt{2g}}{D^2} \cdot d^2\end{aligned}$$

to give

$$\frac{dn}{dt} = K [\text{sign}(\alpha + \beta - \eta)] \sqrt{|\alpha + \beta - \eta|} \quad (10)$$

The functions  $\alpha$  and  $\beta$  are easily generated on the computer by solving the equation of simple harmonic motion (i.e.  $\ddot{x} = -\omega^2 x$ ). The requisite components are shown in Sections 3 and 4 of Fig. 9.

A function generator (Section 1, Fig. 9), in conjunction with a diode circuit, produces  $[\text{sign}(\alpha + \beta - \eta)] \sqrt{|\alpha + \beta - \eta|}$ . The function generator by itself is not sufficient because it can not be set to give an infinite slope, as required at the origin by  $y = [\text{sign} x] \sqrt{|x|}$ . The diode circuit provides the infinite slope segment.

Section 5 sums  $\alpha$  and  $\beta$  to give a forcing function output. Section 6 is a time base generator used with an x-y recorder to produce traces as a function of time. The remaining circuitry, Section 2, supplies the final links to produce the desired solutions.

Amplitude and frequency of the forcing functions is controlled by the potentiometers and capacitors associated with Sections 3 and 4. Any desired initial conditions can be provided by the initial condition power supplies. Hole size is changed simply by stacking resistors in parallel, as shown in Section 1.

#### Ripple-free case

The first case examined consisted of a primary tide only ( $\beta=0$ ) with two periods and various amplitudes. The period of 31.4 seconds corresponds to a semi-diurnal tide in the model. The value of  $d$  was varied from one-sixteenth to one-half inch in increments of one-sixteenth inch. A typical group of solutions is shown in Fig. 10.

Information from all solutions obtained is tabulated in Table I and displayed graphically in Fig. 11 through 14. Certain conclusions may be immediately drawn. For a given value of  $d$ , the amplitude response varies inversely with tidal amplitude and directly with the period. Similarly, phase lag varies directly with tidal amplitude (and directly with the period for hole sizes of 3/16 inch or less). For a given amplitude of tide,

amplitude response varies directly, and phase lag varies inversely, with the hole size.

The minimum hole size required to provide any desired percentage of amplitude response, for any particular tidal amplitude, can be obtained from Fig. 11. For example, to assure a 100% amplitude response for a semi-diurnal tide of one inch range (the maximum in the model) requires a minimum hole size of three-eighths inches. However, this applies only to the ripple-free case. The filtering action of the stilling wells on ripple components cannot be ascertained from these (or similar) graphs because of frequency coupling effects when two or more frequencies of oscillation are present at the same time.

#### Tide with superimposed ripple

Response curves of the type shown in Fig. 15 result for the case  $\beta \neq 0$ . Solutions for various values of ripple amplitude and frequency were obtained. The pertinent data from these curves is tabulated in Table II, and shown graphically in Fig. 16 through 21. Again it can be seen that amplitude response varies directly with the primary tide period for a given hole size. Also, for a given amplitude and period of tide, amplitude response varies directly, and phase lag varies inversely, with the hole size (as before). Further, it is clear that both amplitude response and phase lag are nearly independent of ripple amplitude and frequency for the values shown. Any slight dependence which may exist is certainly overshadowed by the variations with hole size.

The amount of ripple penetrating the filter was measured at the peaks of the response curves (high and low water amplitudes and times are the important features of the model tide records). The data is listed in Table III and plotted in Fig. 22 through 24. It is seen that the percentage of ripple damped out varies directly with ripple amplitude and inversely with ripple period, for a constant hole size. For constant ripple, the percentage damped is inversely proportional to the hole size.

#### Choice of inlet hole size

It is evident from Fig. 22 that the hole size must be kept as small as possible to provide adequate ripple damping over a wide range of ripple amplitudes and frequencies. This requirement is exactly opposed to that required for good amplitude and phase response of the primary tide (Fig. 16 and 17). A compromise must be made.

The value of hole size finally chosen was nine-thirty-seconds of an inch. This size ensures at least a 90% amplitude response with very little phase lag. At the same time, 65% or more of the most troublesome ripple is damped out. A graph combining these criteria is shown in Fig. 25.

An indication of the improvement in tide records obtained with the aid of a stilling well is given in Fig. 26. It is seen that the wells are admirably suited to the purpose for which they were designed.

W.H. Bell  
N.E.J. Boston

Table I. Values obtained from curves using a primary tide only and various hole sizes

Hole size d (inches)	Tidal Period T (sec)	Tidal Amplitude A (inches)	Stilling Well Phase Lag (sec)	Stilling Well Response (R) (inches)	Normalized Response R/A
1/16	31.4	1.0	9.0	.060	.060
1/8	"	"	6.4	.250	.250
3/16	"	"	5.4	.523	.523
1/4	"	"	3.9	.805	.805
5/16	"	"	2.4	.952	.952
3/8	"	"	1.4	1.000	1.000
1/16	31.4	0.5	7.8	.042	.084
1/8	"	"	6.3	.166	.332
3/16	"	"	4.4	.328	.656
1/4	"	"	2.7	.450	.900
5/16	"	"	1.4	.496	.992
3/8	"	"	0.9	.500	1.000
1/16	31.4	0.25	7.0	.031	.124
1/8	"	"	5.6	.114	.456
3/16	"	"	3.3	.206	.825
1/4	"	"	1.6	.242	.968
5/16	"	"	1.1	.250	1.000
3/8	"	"	0.7	.250	1.000
1/16	15.7	0.25	4.0	.015	.060
1/8	"	"	3.3	.059	.236
3/16	"	"	2.7	.125	.500
1/4	"	"	1.8	.192	.768
5/16	"	"	1.2	.234	.936
3/8	"	"	0.7	.250	1.000
1/16	15.7	.125	3.8	.011	.088
1/8	"	"	3.2	.042	.336
3/16	"	"	2.3	.081	.648
1/4	"	"	1.4	.112	.888
5/16	"	"	0.7	.125	1.000
1/16	15.7	.04	3.7	.006	.150
1/8	"	"	2.6	.024	.600
3/16	"	"	1.2	.038	.951
1/4	"	"	0.2	.040	1.000
5/16	"	"	0.0	.040	1.000

Table II. Values obtained from curves using a primary tide with superimposed ripple and various hole sizes.

Hole Size d (inch)	Tidal Amp. A (inch)	Tidal Period $T_A$ (sec)	Ripple Amp. B (inch)	Ripple Period $T_B$ (sec)	Stilling Well Mean Response $\bar{R}$ (inch)	Normalized Mean Resp. $\bar{R}/A$	Stilling Well Phase Lag (sec)
1/8	.25	31.4	.0732	2.70	.106	.424	5.8
3/16	"	"	"	"	.190	.760	3.8
1/4	"	"	"	"	.230	.920	1.9
5/16	"	"	"	"	.241	.964	1.6
3/8	"	"	"	"	.244	.976	1.1
1/8	.25	31.4	.0694	1.37	.103	.412	5.4
3/16	"	"	"	"	.191	.764	3.3
1/4	"	"	"	"	.228	.913	1.8
5/16	"	"	"	"	.238	.953	1.2
3/8	"	"	"	"	.244	.976	1.0
3/16	.25	31.4	.0347	1.37	.197	.788	3.3
1/4	"	"	"	"	.234	.936	1.5
5/16	"	"	"	"	.242	.967	1.0
3/8	"	"	"	"	.245	.979	0.9
1/16	.25	31.4	.0745	5.93	.033	.132	7.1
1/8	"	"	"	"	.109	.436	5.3
3/16	"	"	"	"	.200	.800	3.6
1/4	"	"	"	"	.222	.888	2.0
5/16	"	"	"	"	.231	.924	1.4
3/8	"	"	"	"	.237	.948	0.9
3/16	.25	15.7	.0347	1.37	.124	.496	2.6
1/4	"	"	"	"	.182	.728	1.8
5/16	"	"	"	"	.222	.888	1.0
3/8	"	"	"	"	.236	.944	0.9

Table III. Ripple damping data ( $T_A = 31.4$  sec,  $A = 0.25$  inches)

Hole Size $d$ (inch)	Ripple Period $T_B$ (sec)	Ripple Amp. $B$ (inch)	Amplitude of Ripple on peaks of response curve $C$ (inch)	% of Ripple damped $(1 - \frac{C}{B})100$
1/8	1.37	.0694	.0017	97.6
3/16	"	"	.0062	91.0
1/4	"	"	.0108	84.5
5/16	"	"	.0158	77.2
3/8	"	"	.0221	68.2
3/16	1.37	.0347	.0037	89.2
1/4	"	"	.0062	82.0
5/16	"	"	.0125	64.0
3/8	"	"	.0176	49.4
1/8	2.70	.0732	.0035	95.2
3/16	"	"	.0102	86.1
1/4	"	"	.0183	75.0
5/16	"	"	.0326	55.5
3/8	"	"	.0433	40.8
1/16	5.93	.0745	0	100.00
1/8	"	"	.0040	94.6
3/16	"	"	.0125	83.2
1/4	"	"	.0310	58.3
5/16	"	"	.0534	28.3
3/8	"	"	.0662	11.1



Figure 1.

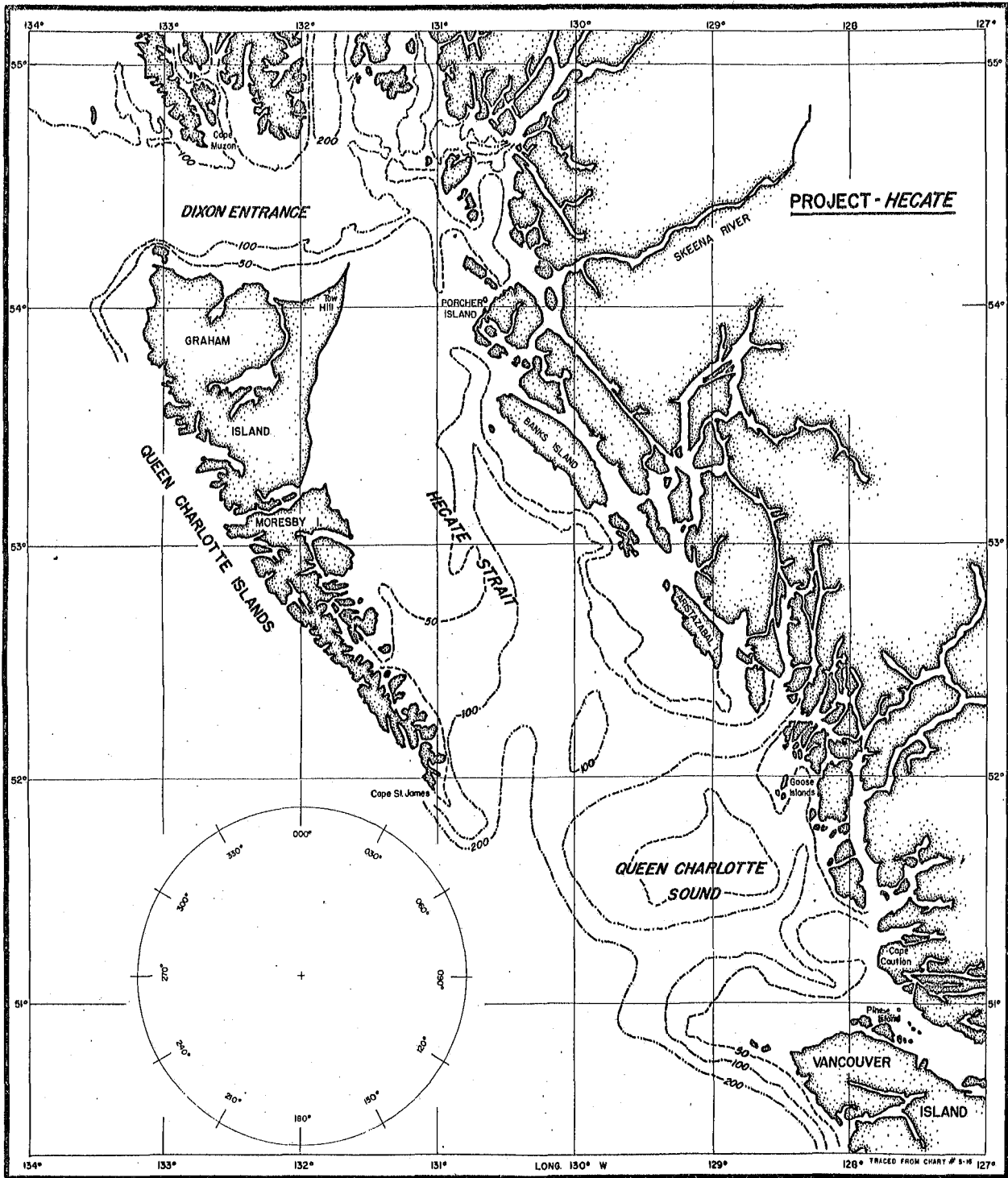

Figure 2.

# METHOD OF TIDE GENERATION

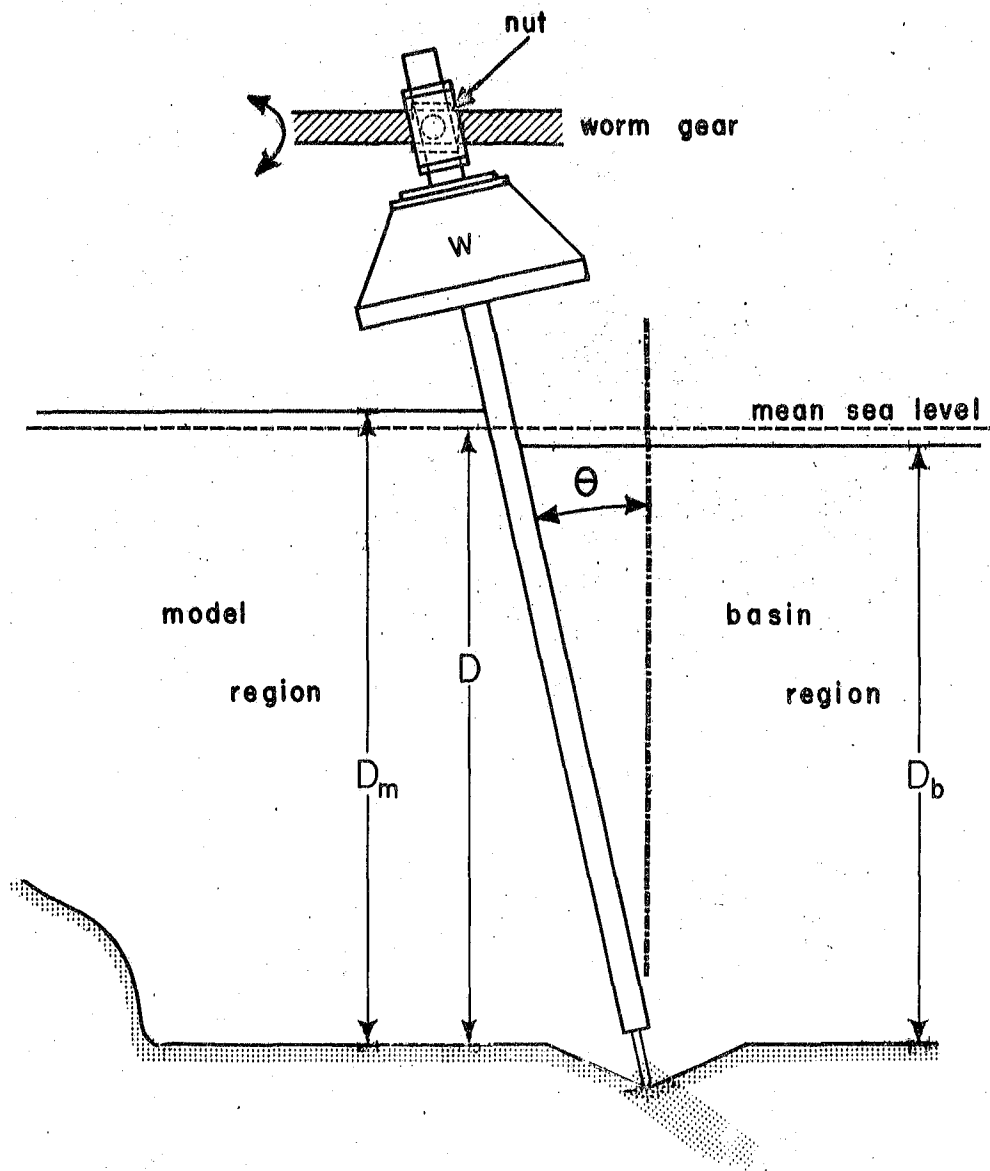

Figure 3.

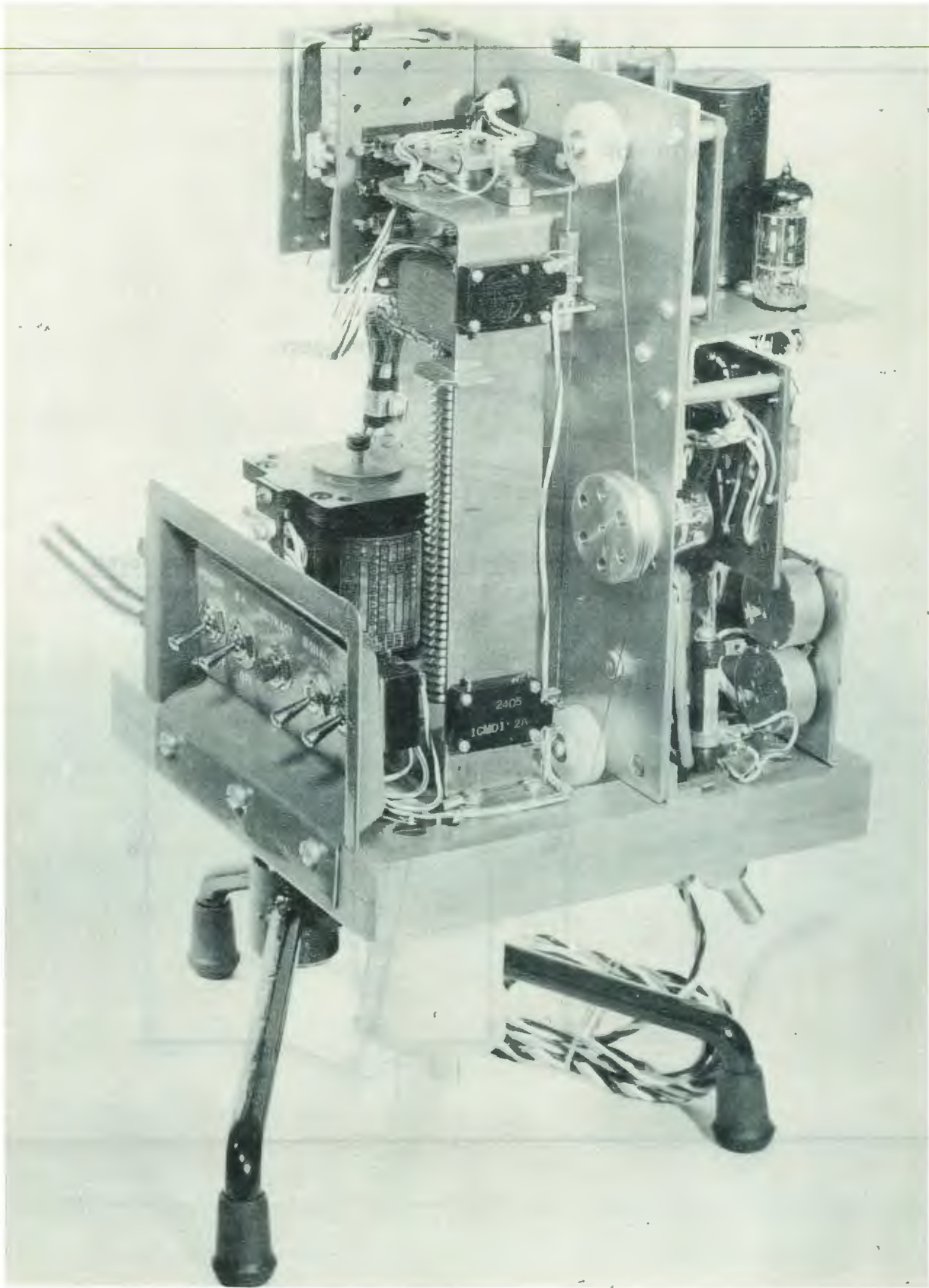

Figure 4.

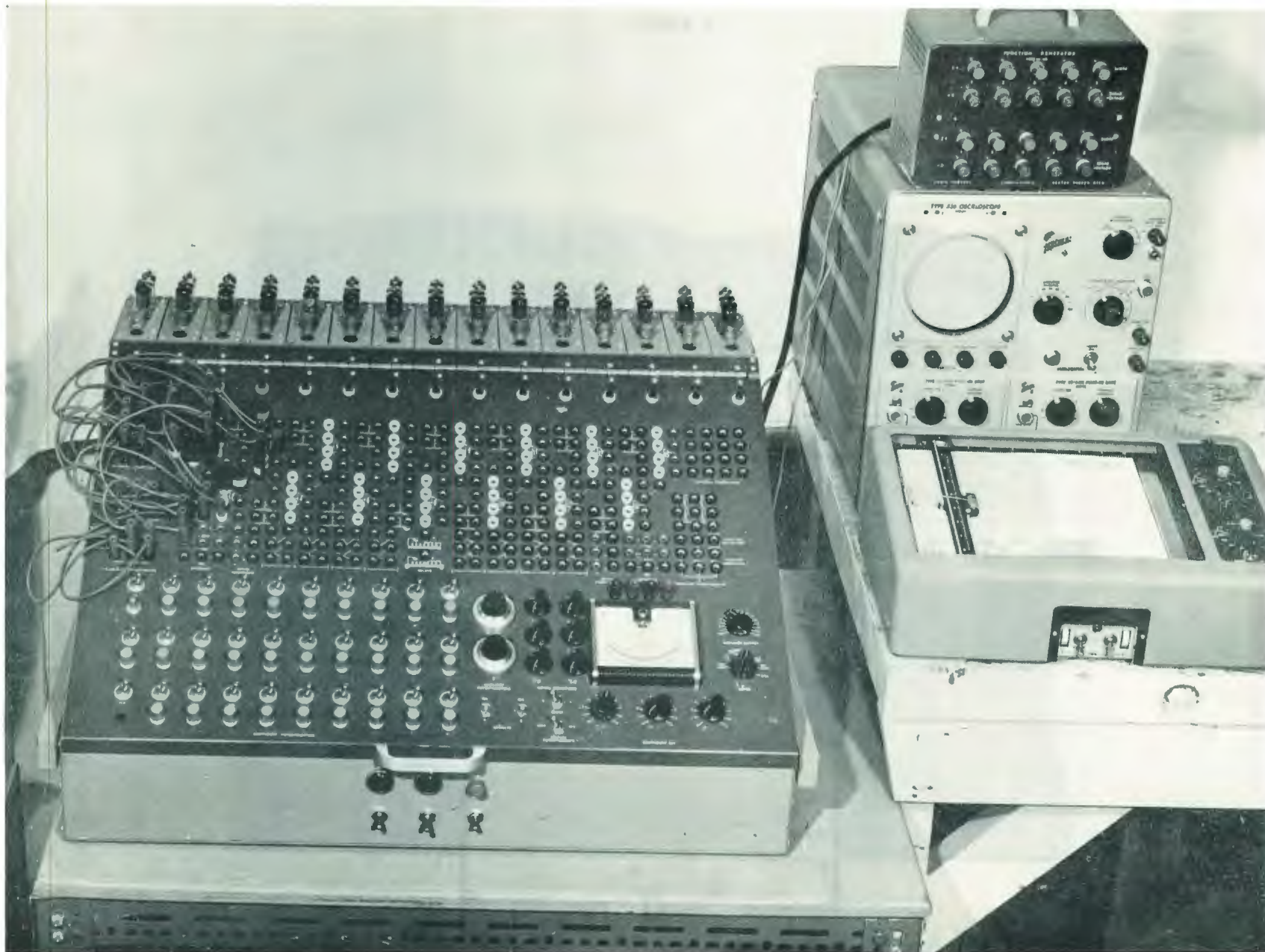

Figure 5.

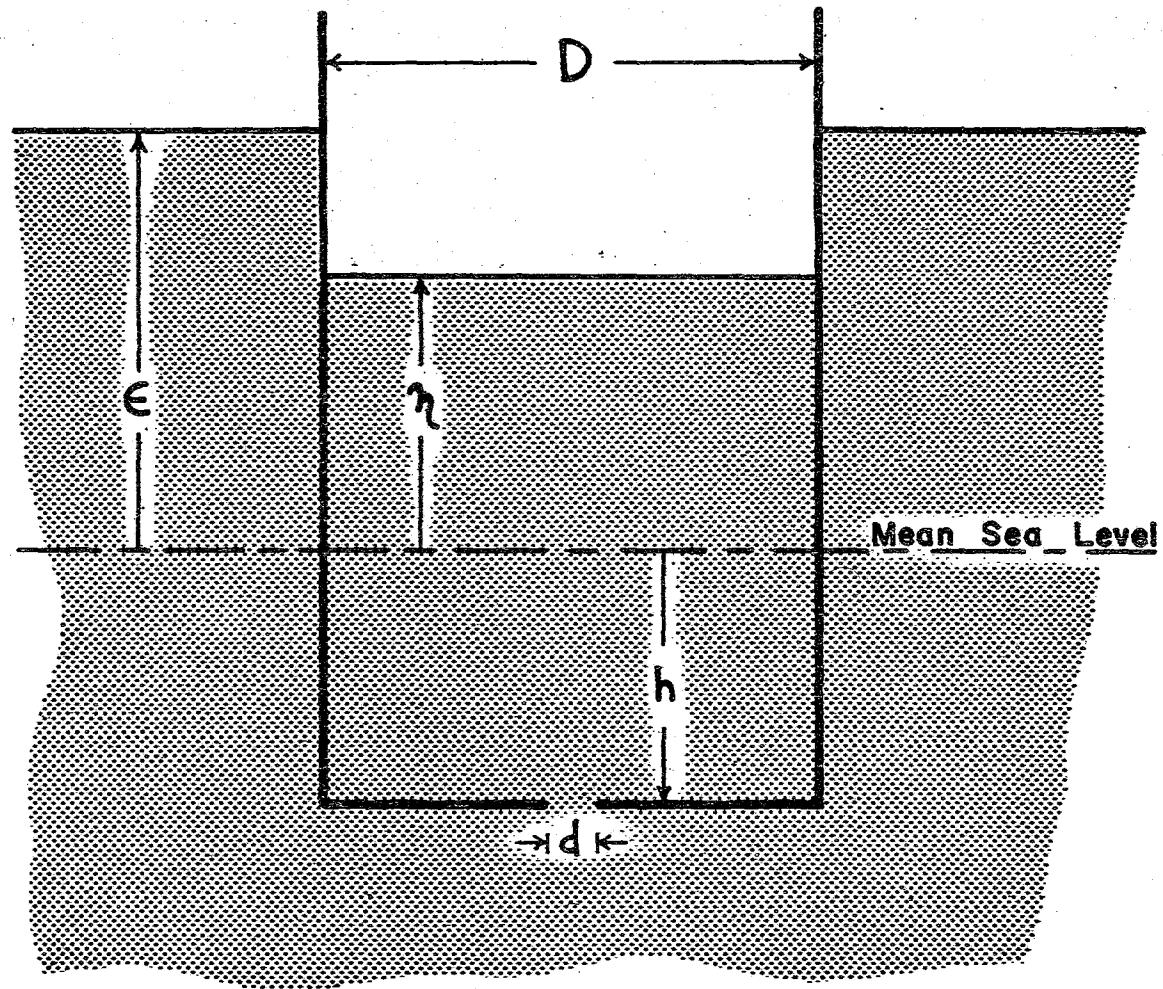

Figure 6.

# STILLING WELL FILLING CURVES

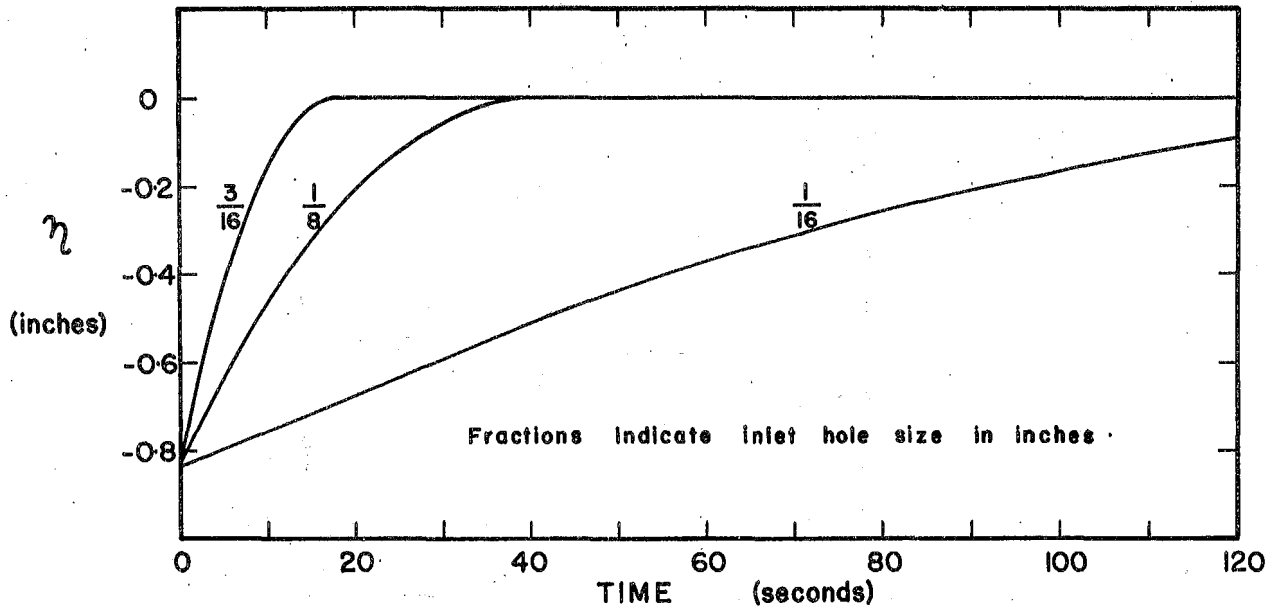
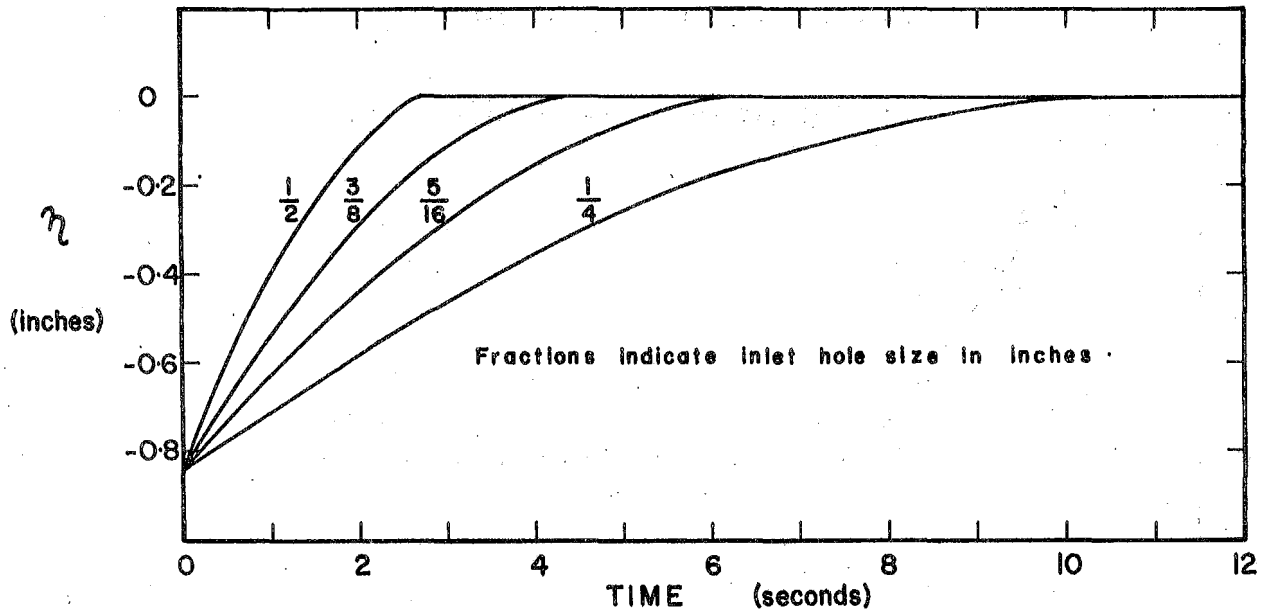

Figure 7.

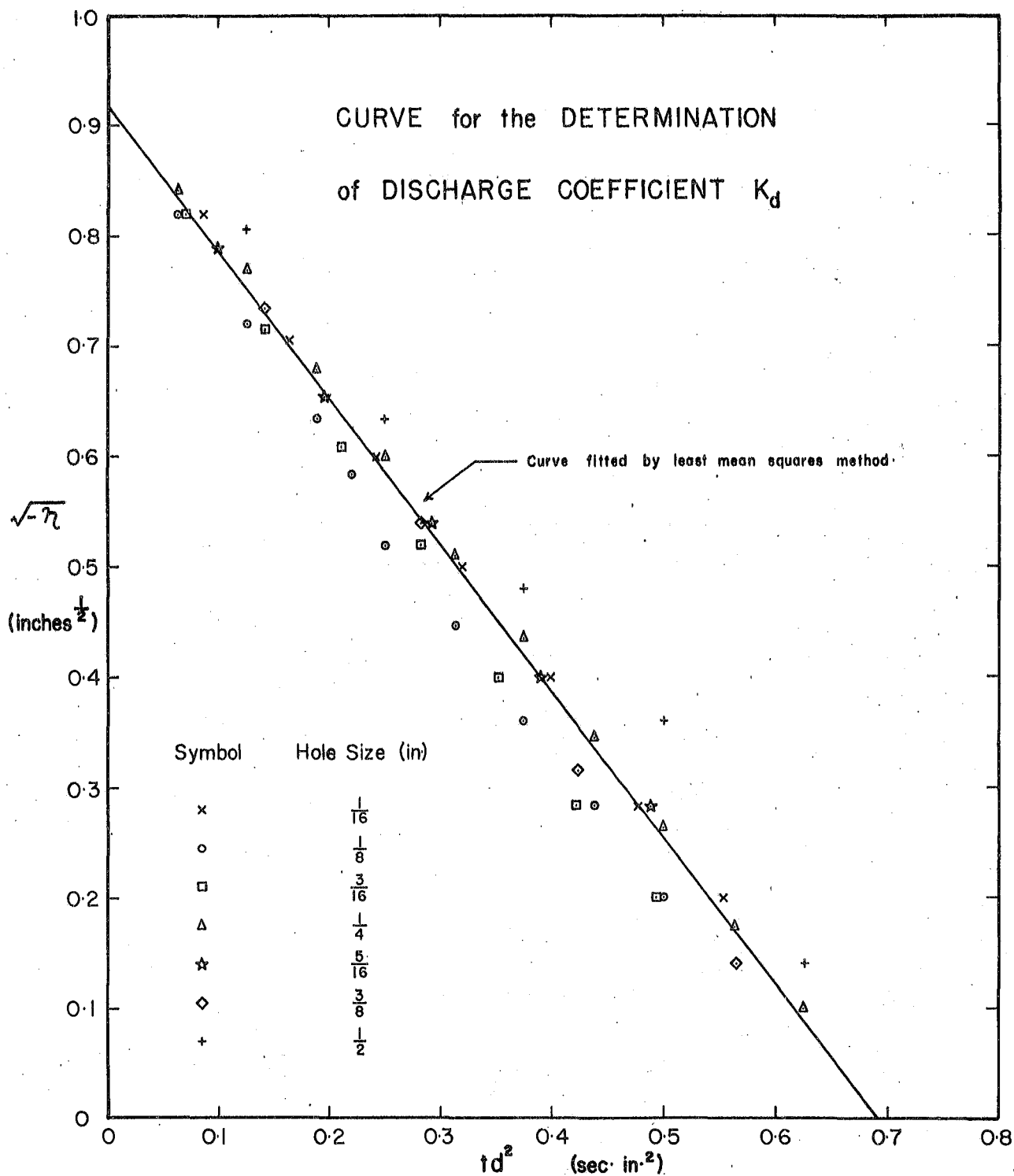

Figure 8.

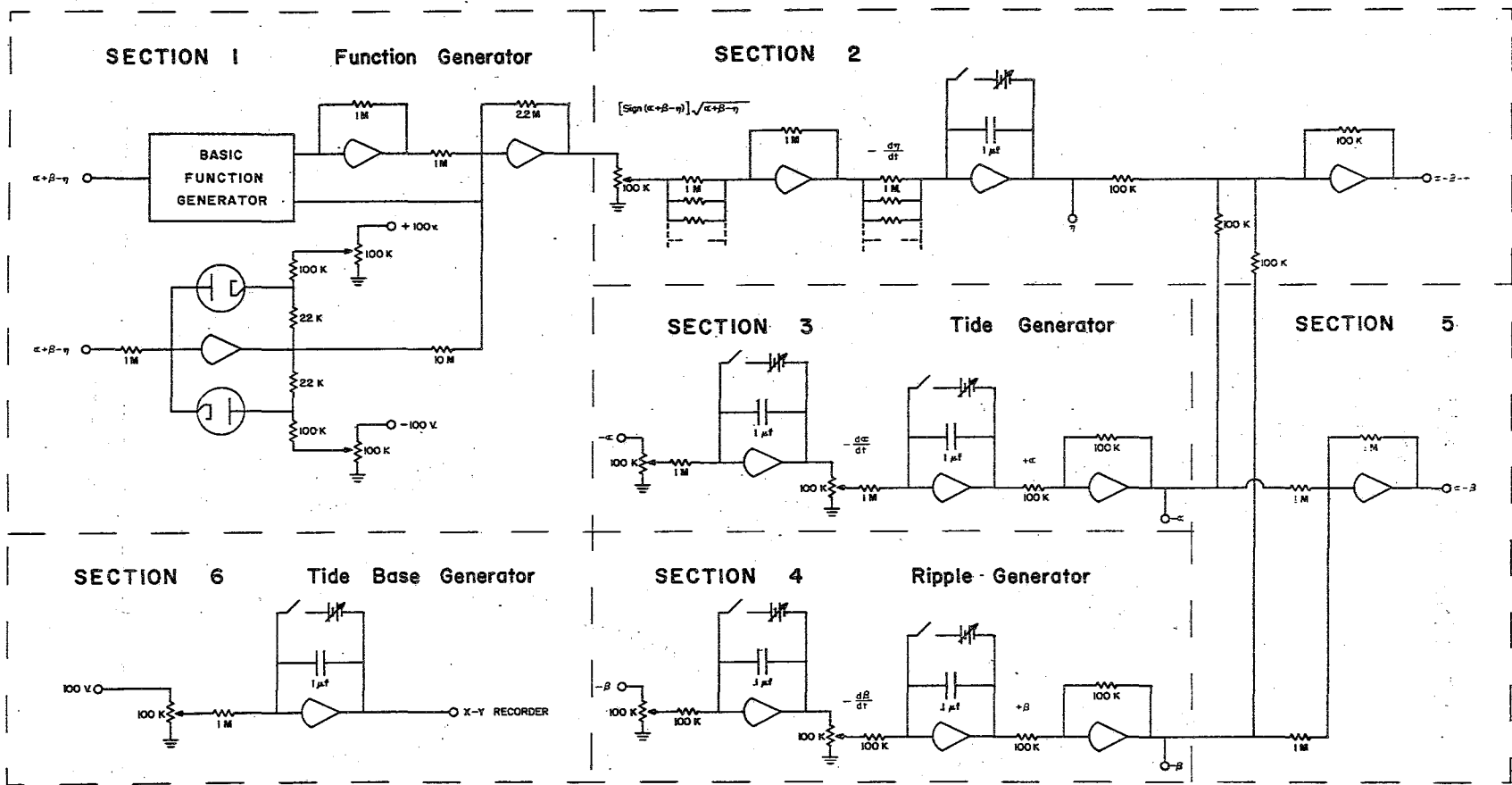

Figure 9.

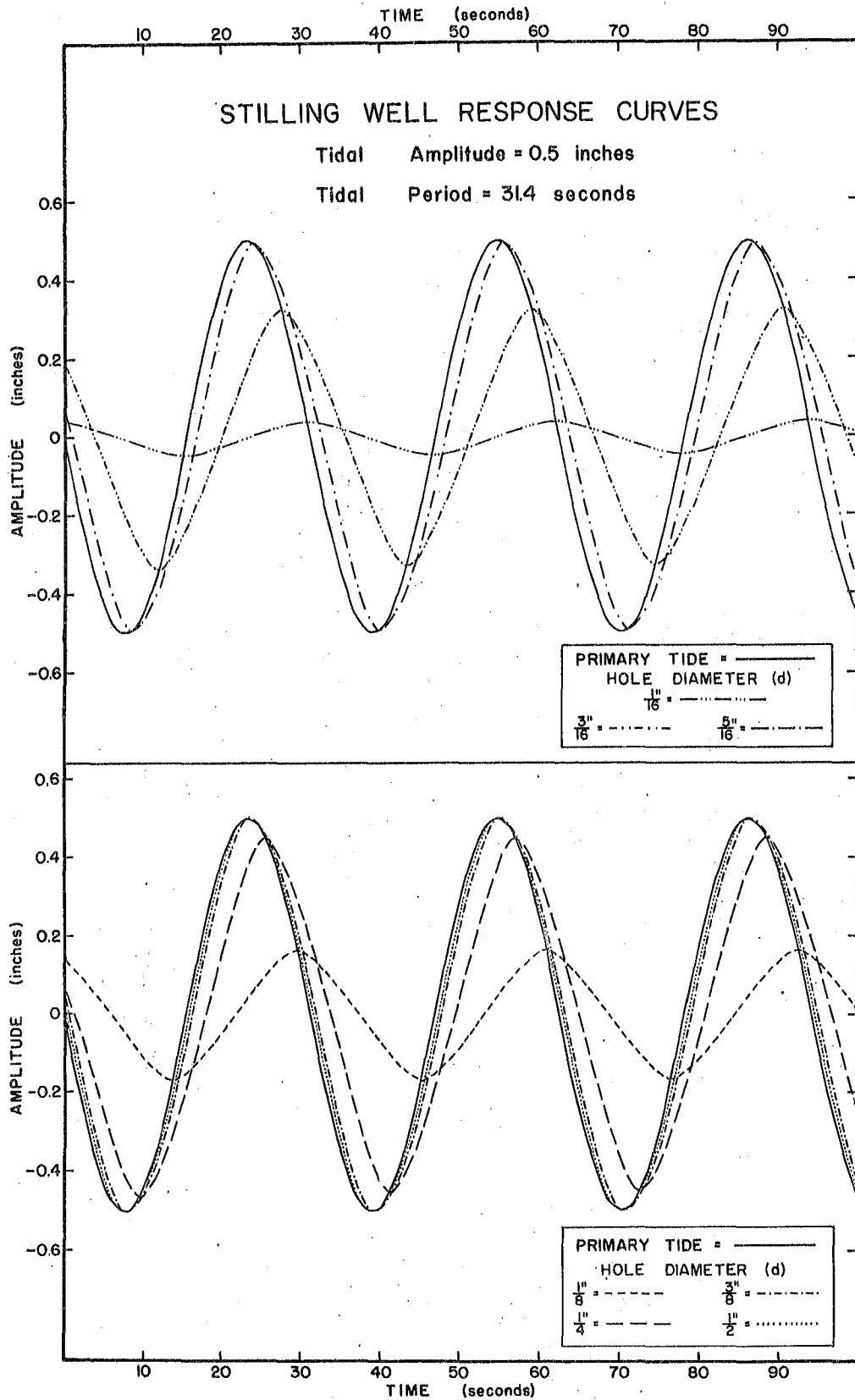

Figure 10.

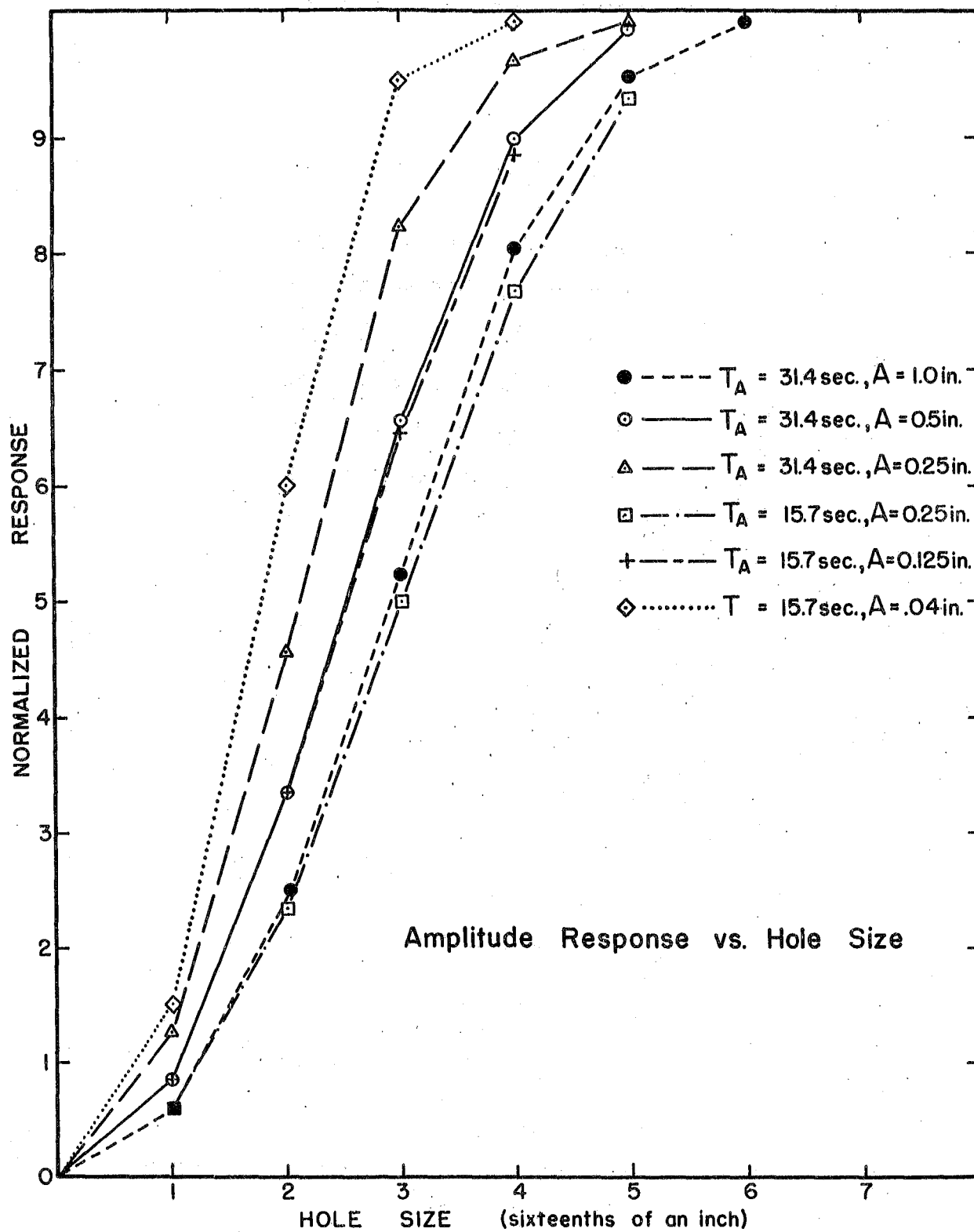

Figure 11.

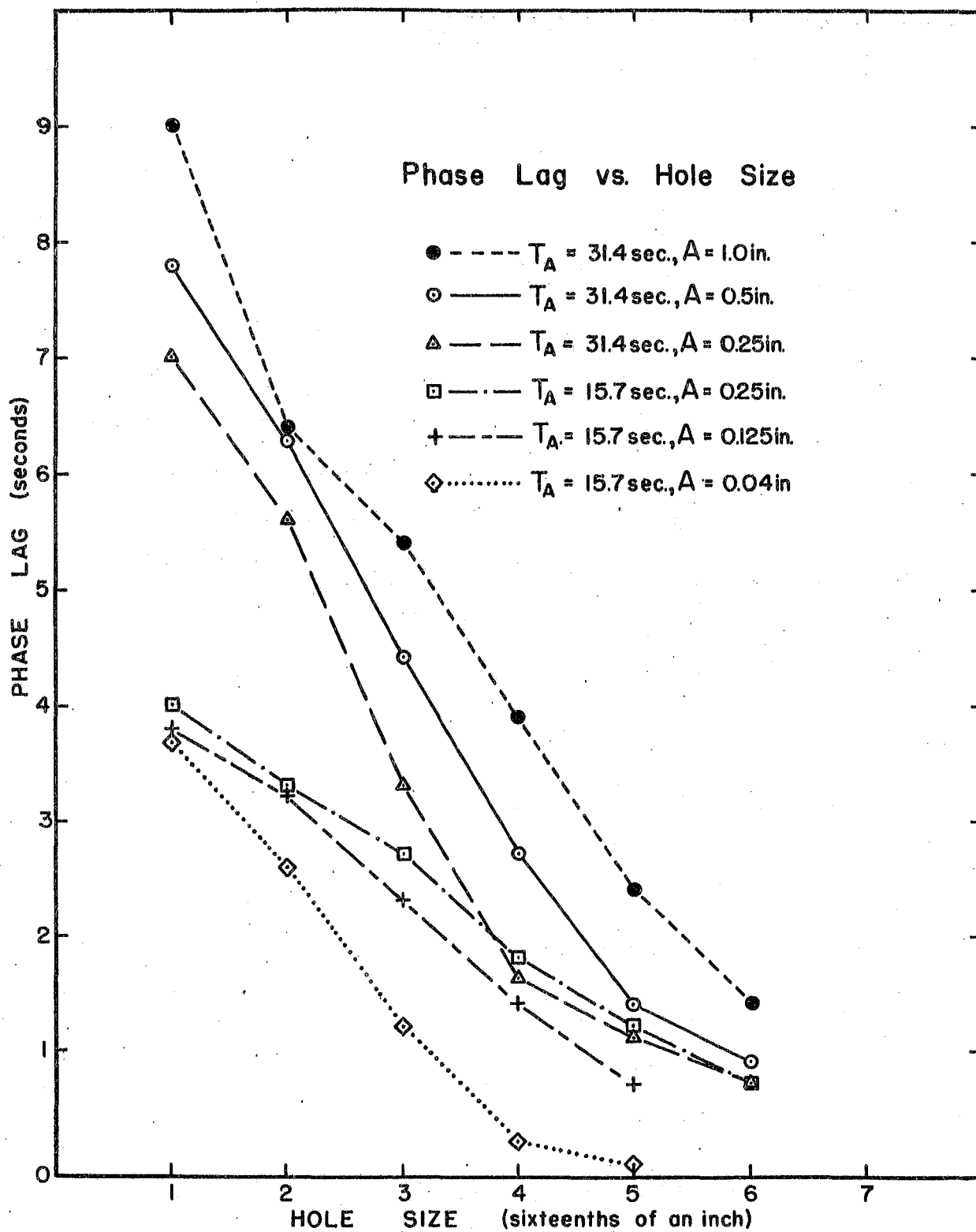

Figure 12.

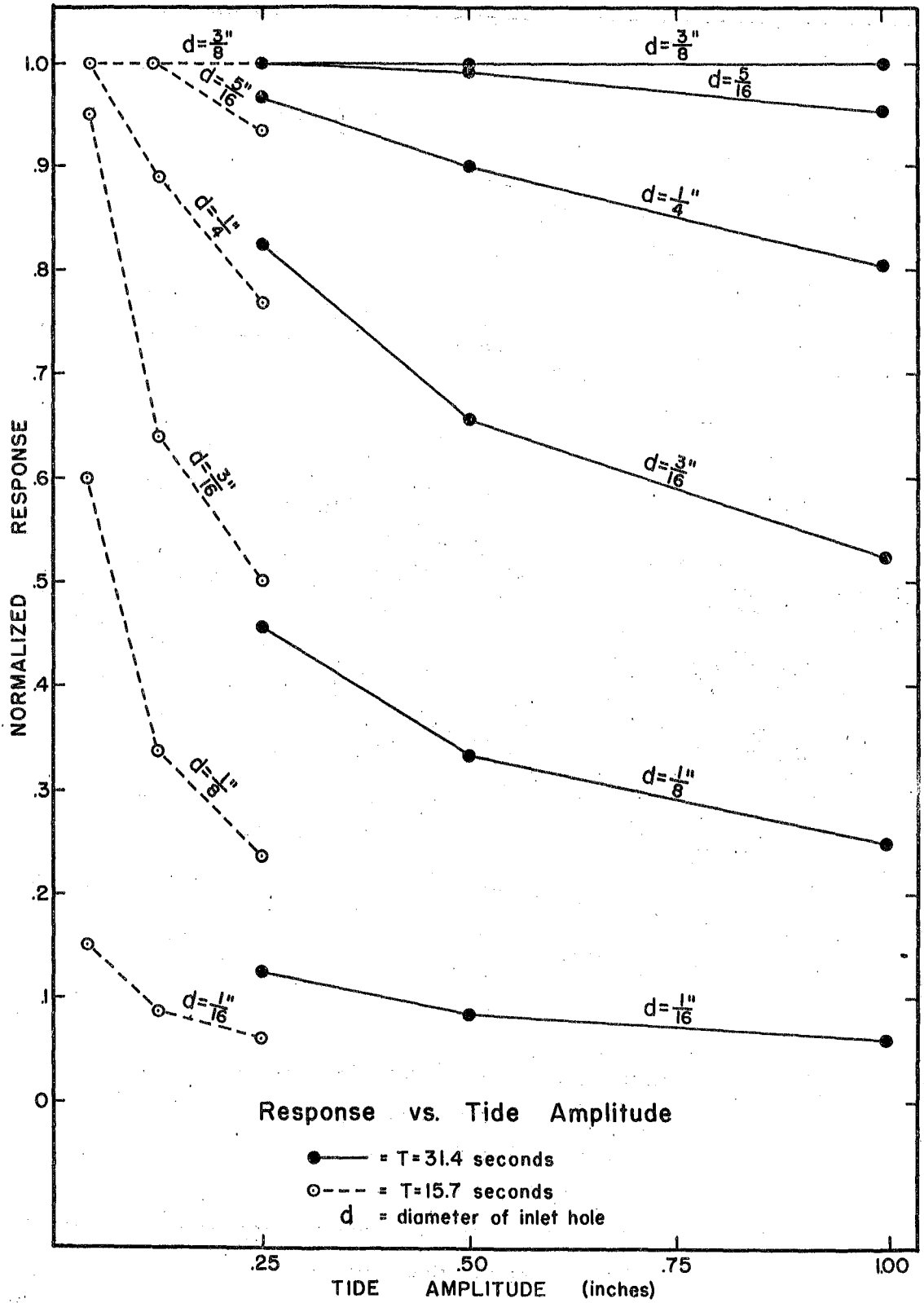

Figure 13.

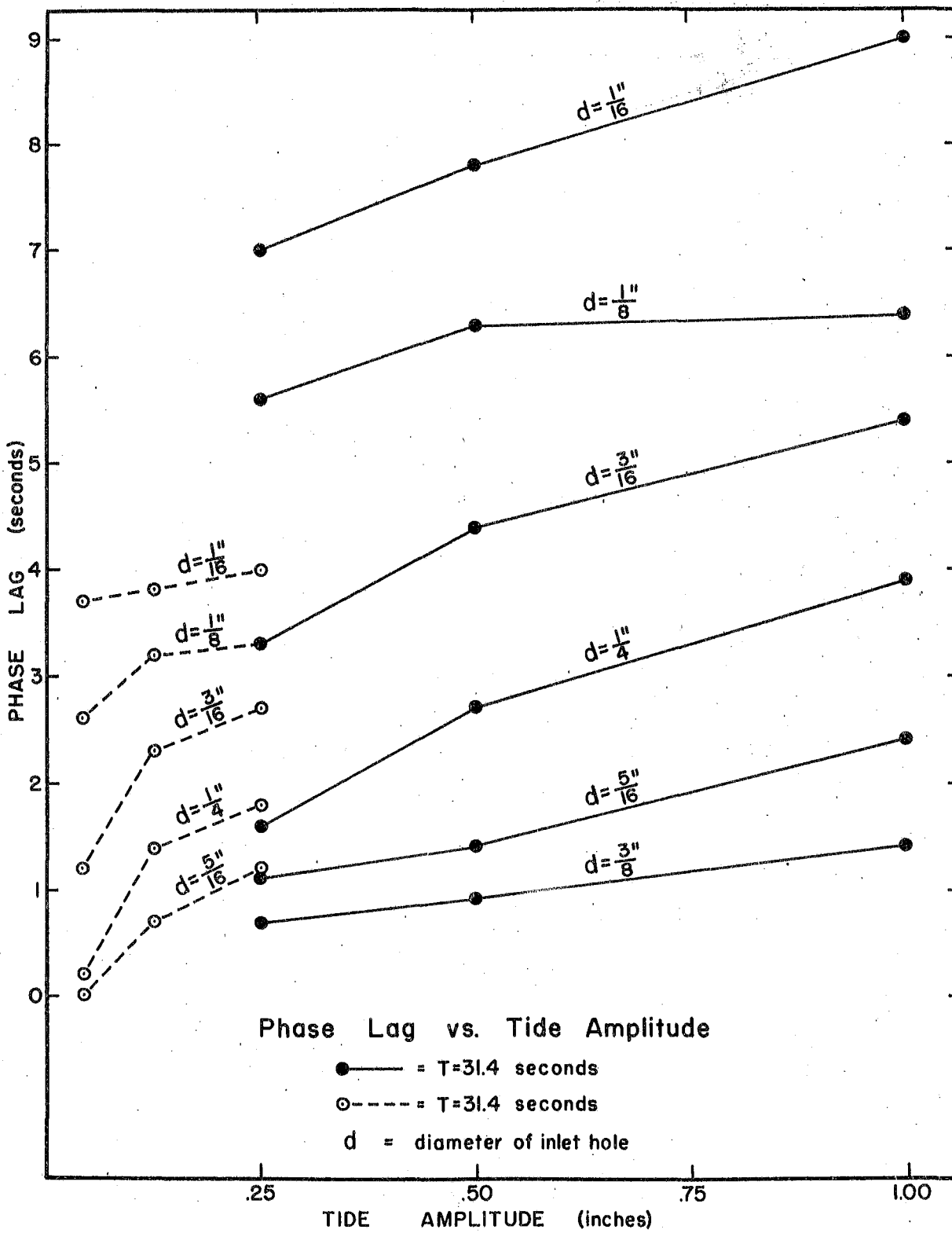

Figure 14.

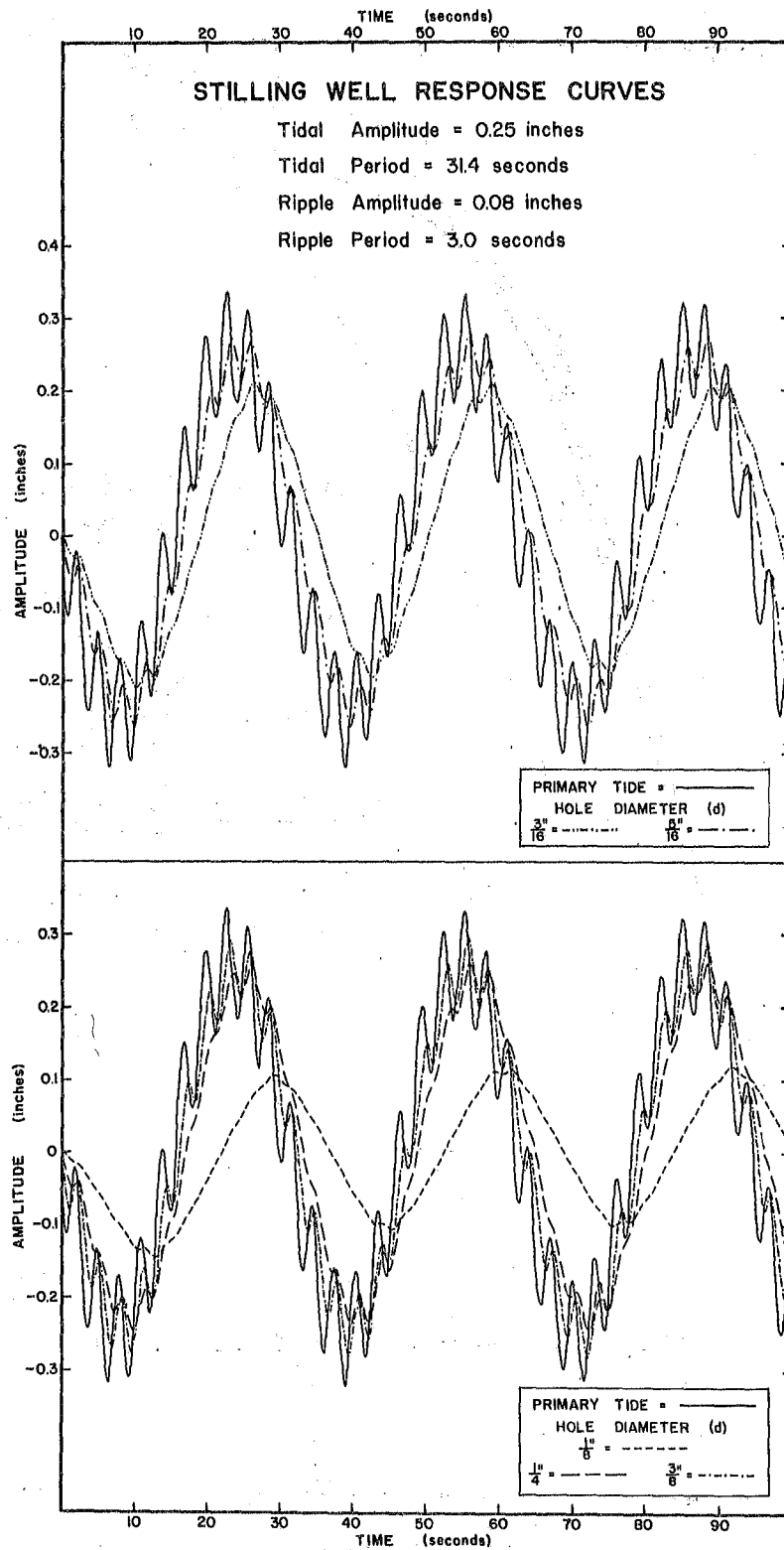

Figure 15.

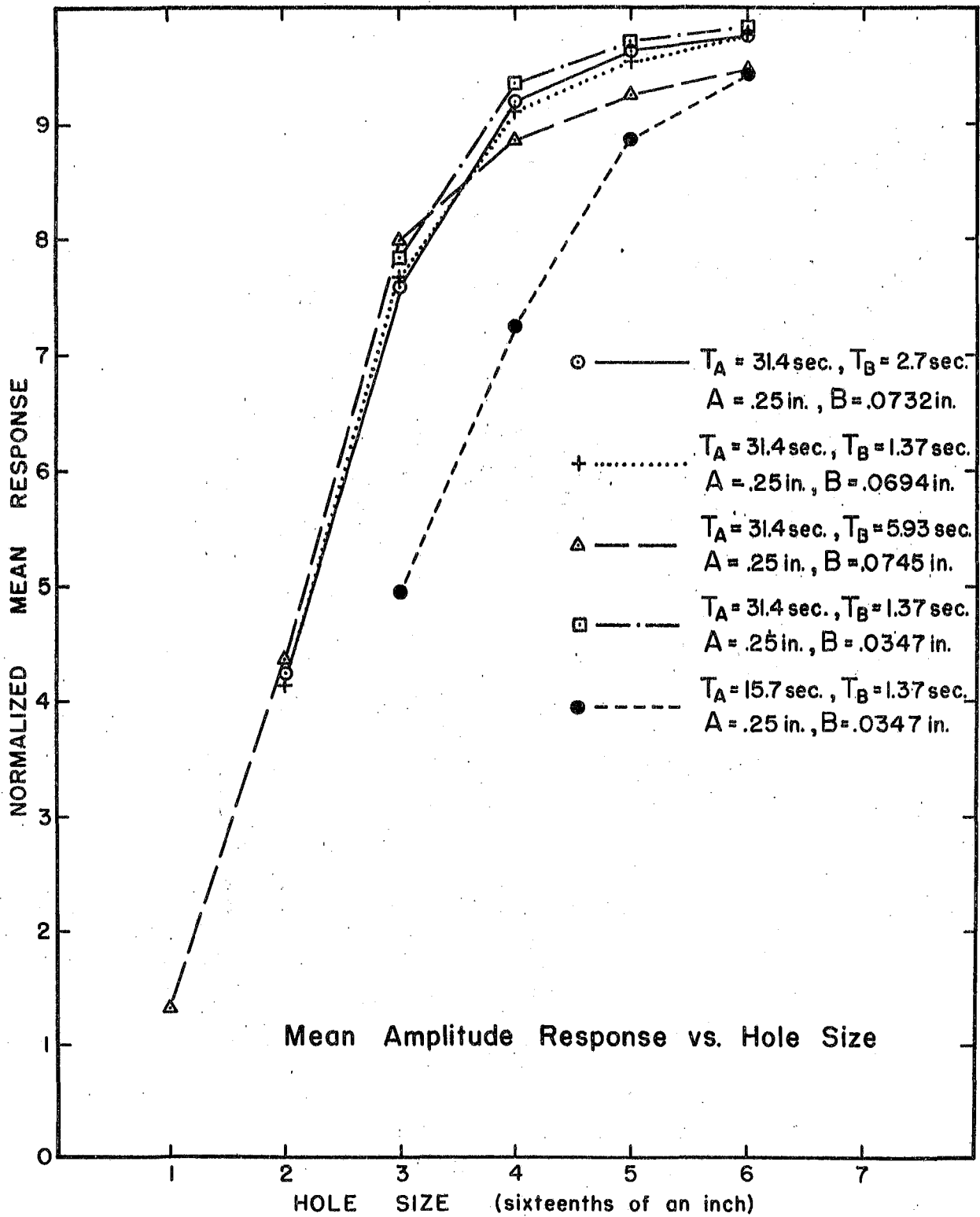

Figure 16.

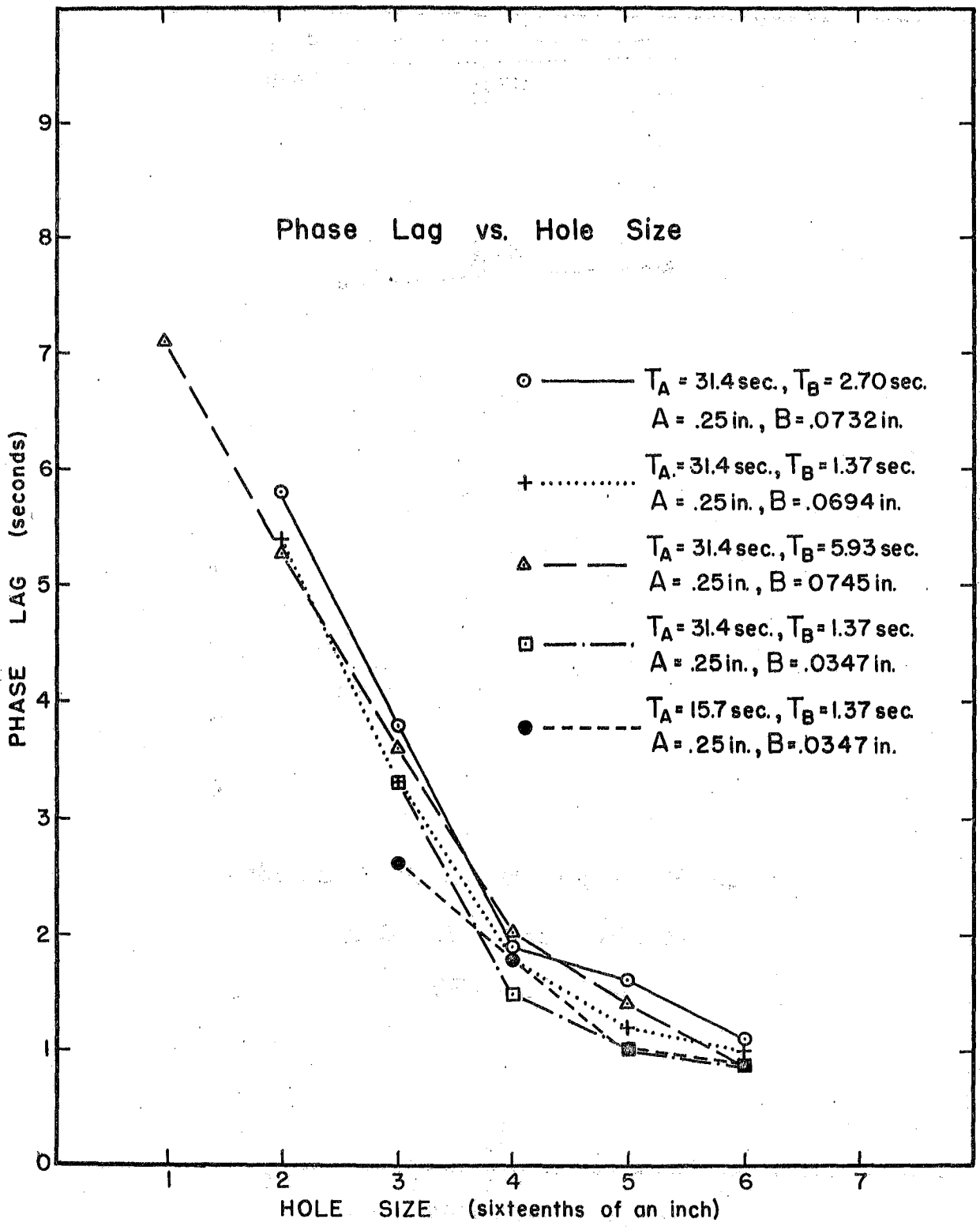

Figure 17.

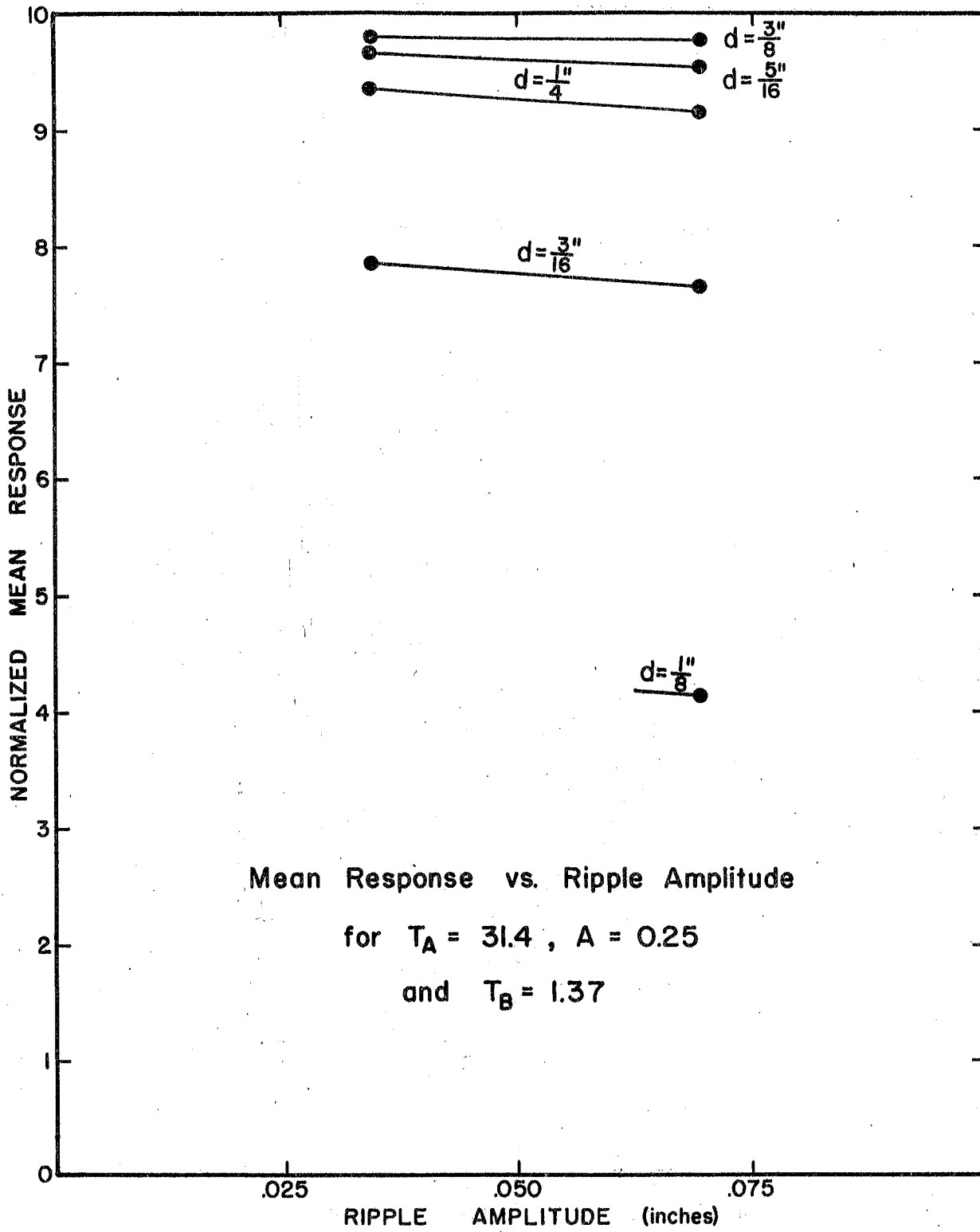

Figure 18.

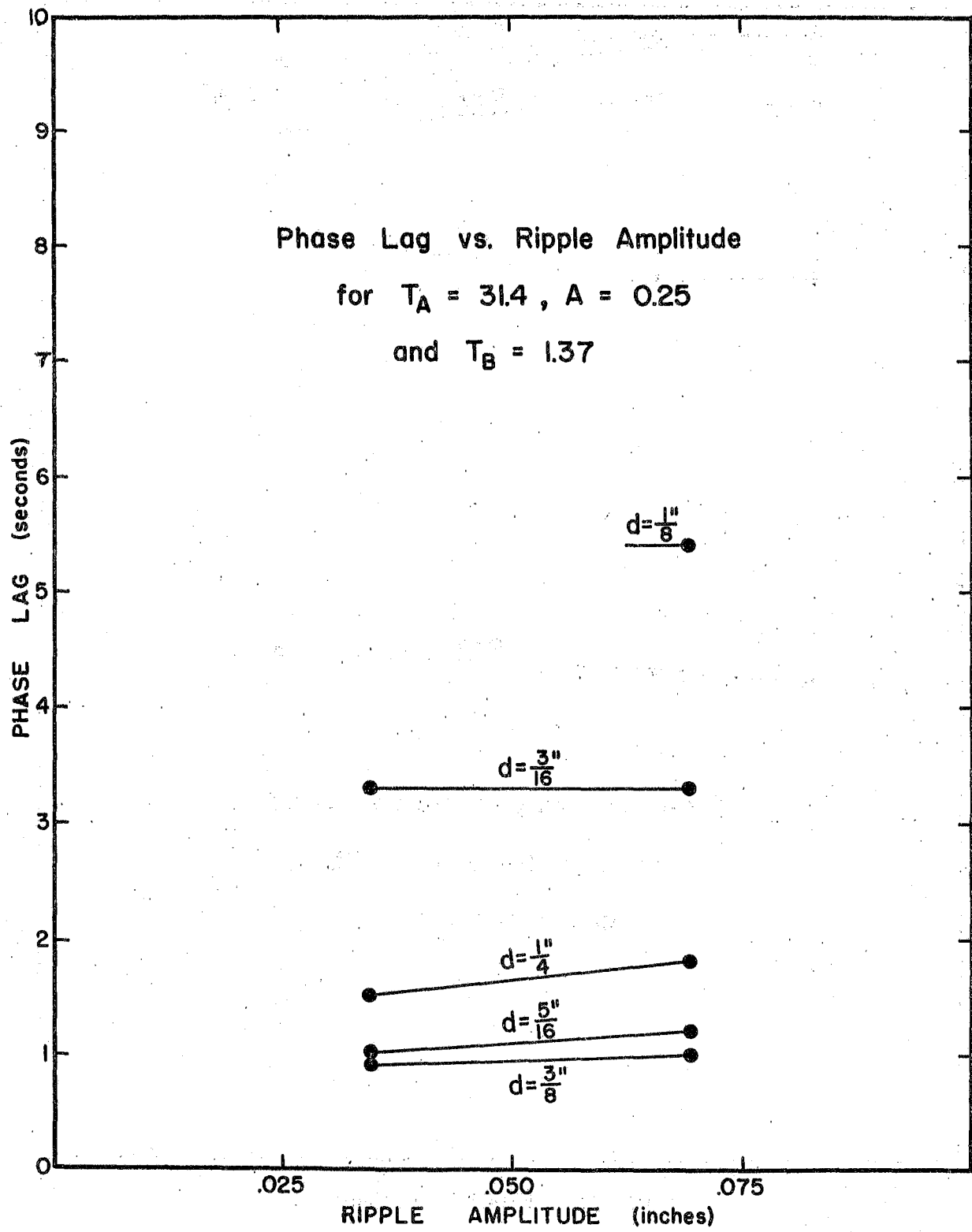

Figure 19.

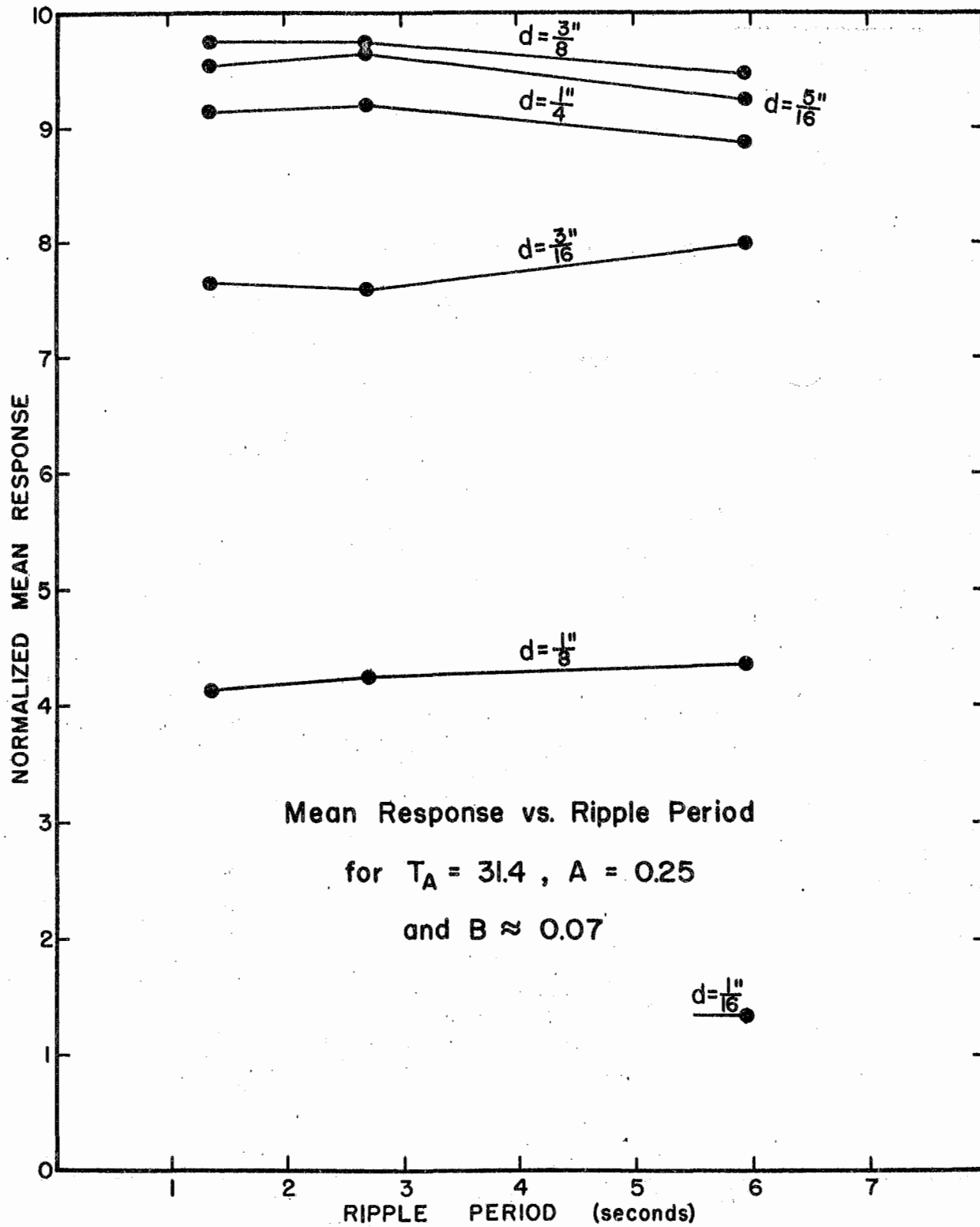

Figure 20.

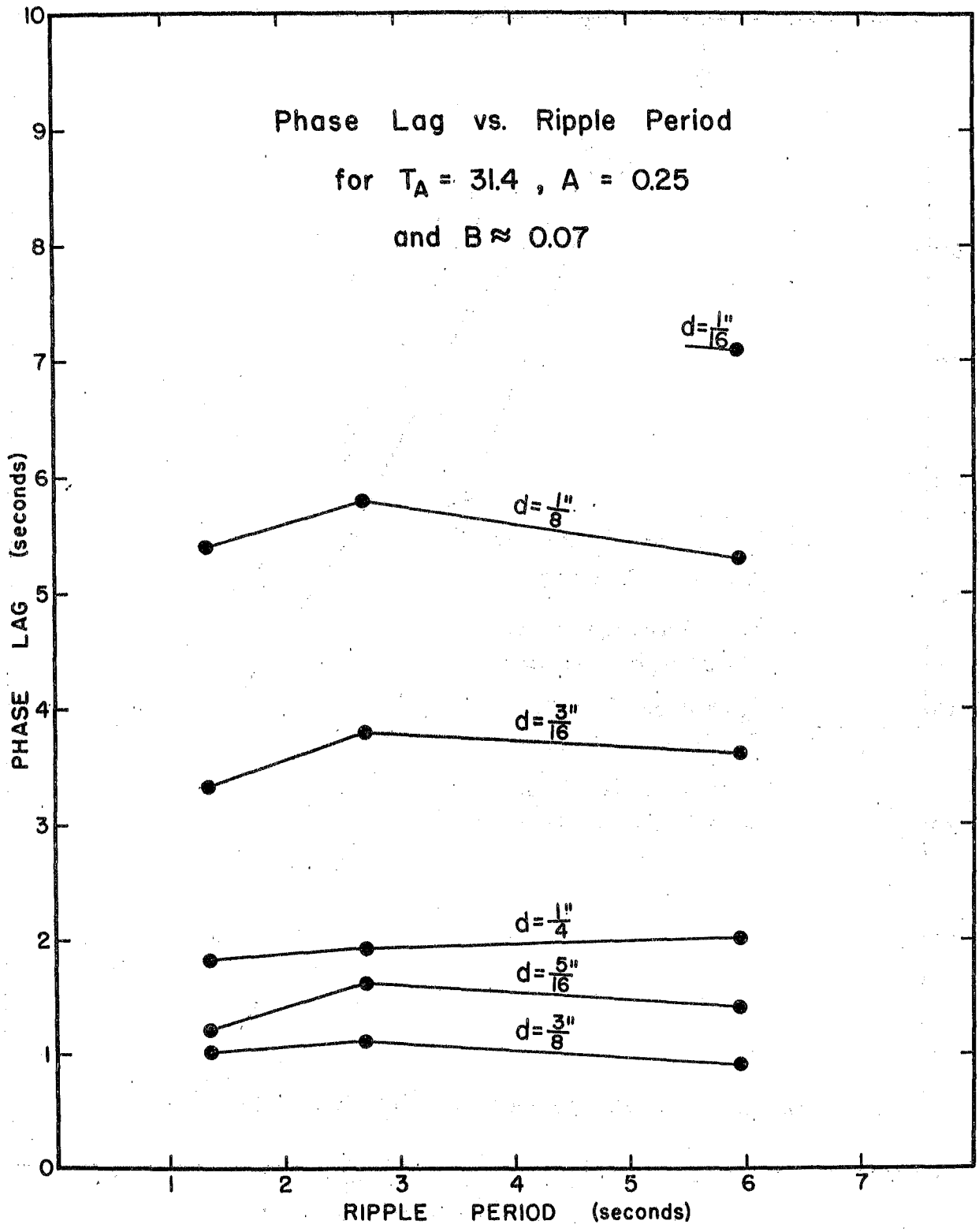

Figure 21.

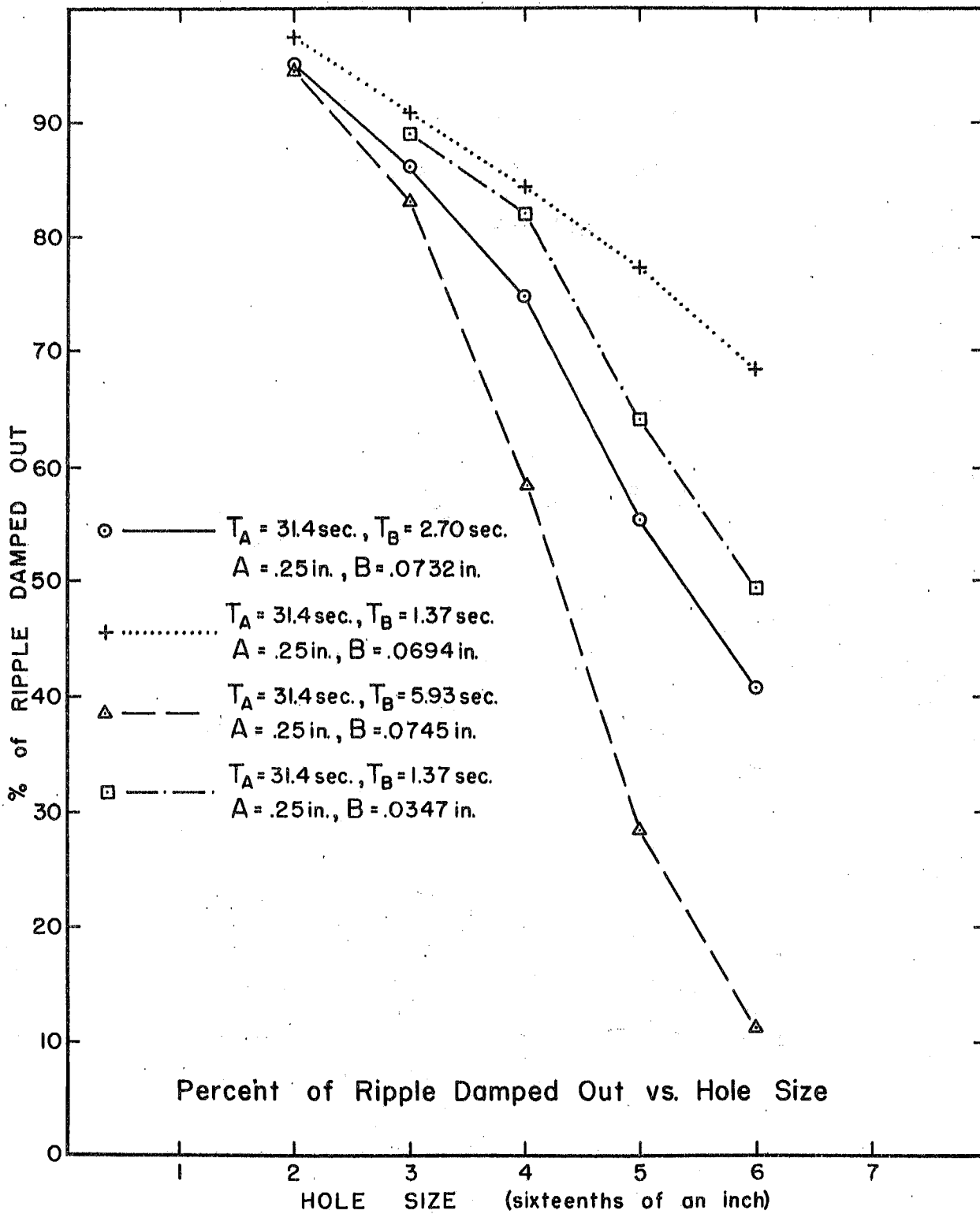

Figure 22.

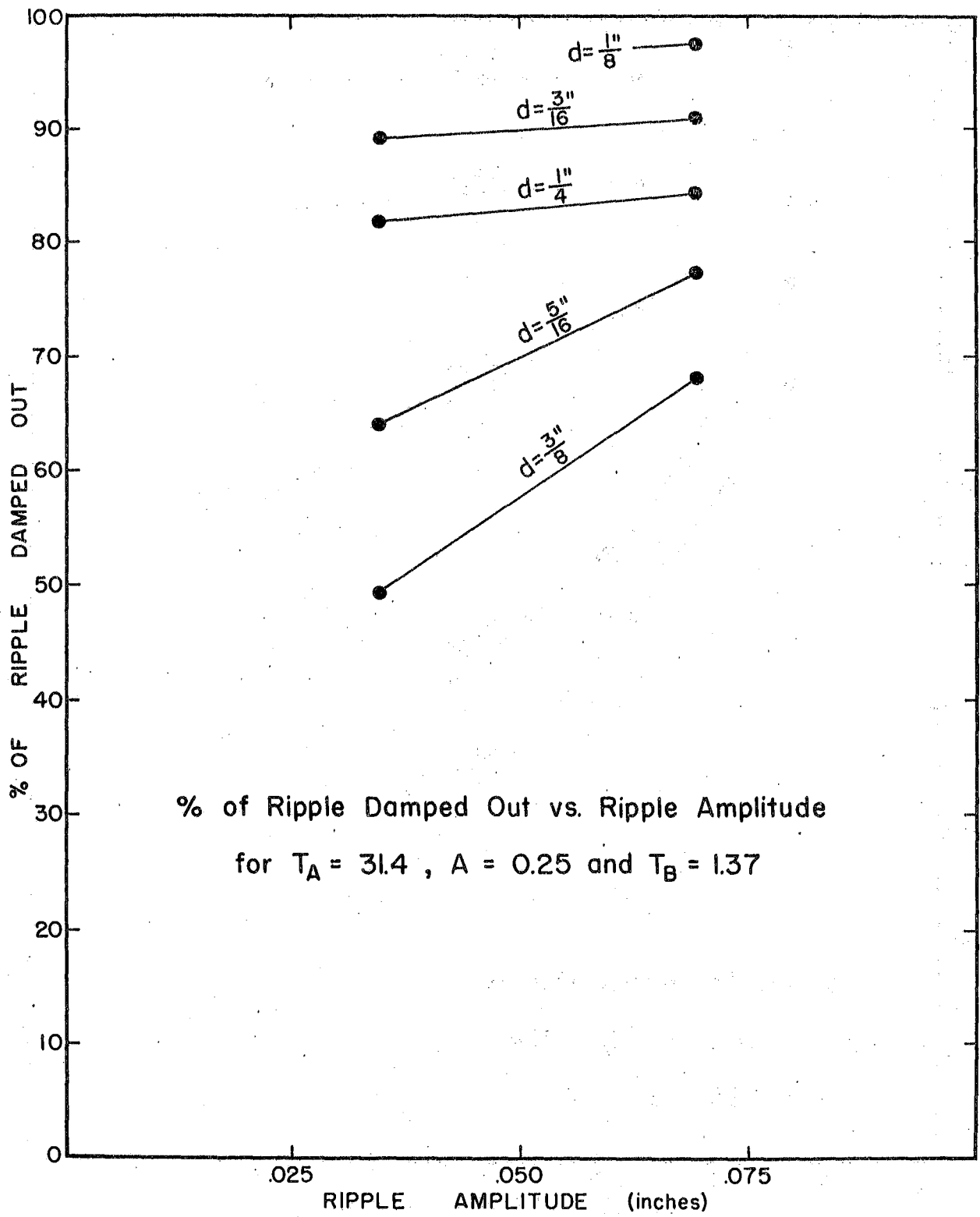

Figure 23.

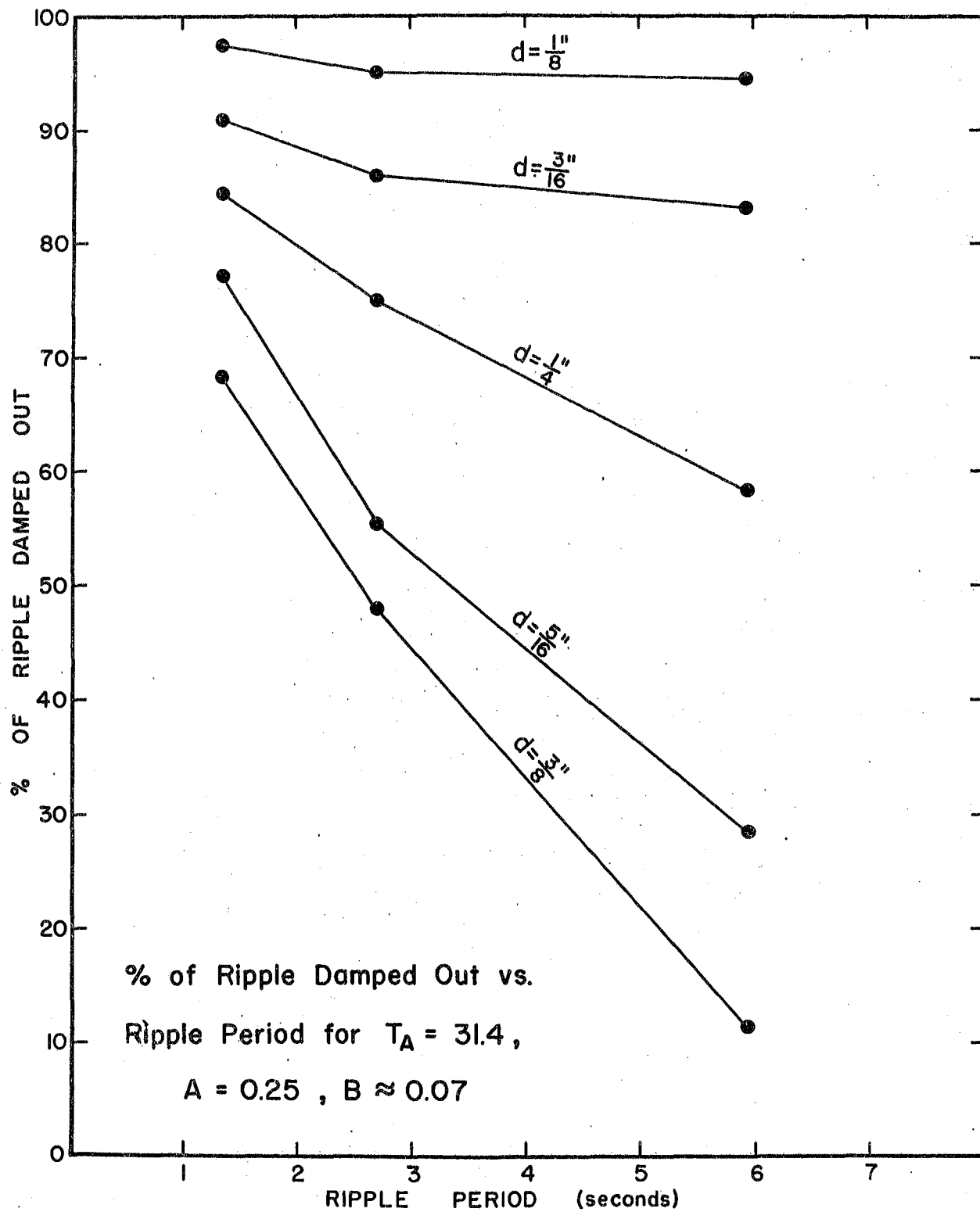

Figure 24.

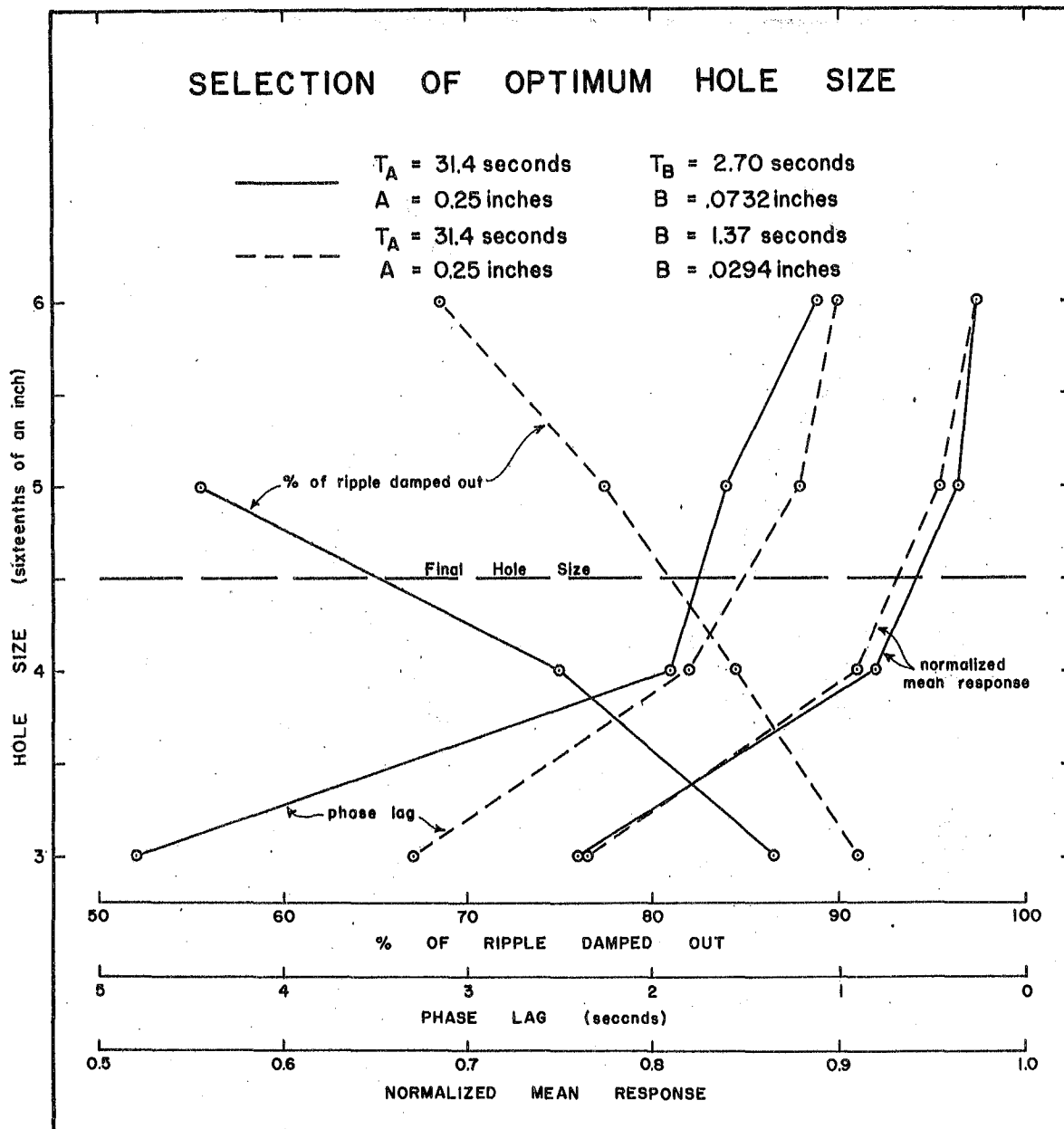

Figure 25.

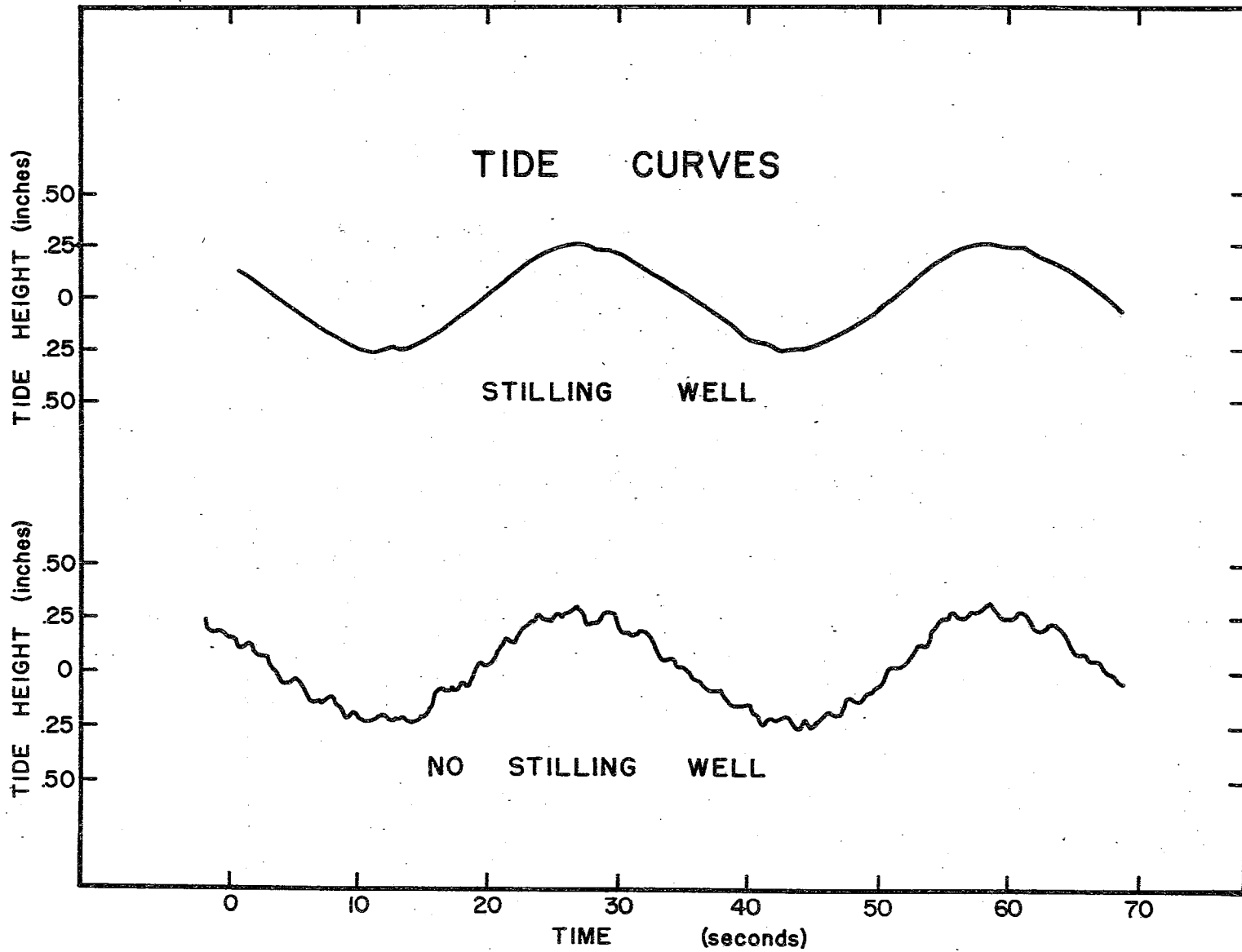

Figure 26.

FISHERIES RESEARCH BOARD OF CANADA  
Pacific Oceanographic Group  
Nanaimo, B. C.

*H. Needler*

*Brook*

Circular 1962 - 2  
January 12, 1962

Transport calculations for the North Pacific Ocean  
September, October 1961

Sverdrup (1947), Stommel (1948), and Munk (1950) have shown that the total steady-state transport of mass in the ocean depends primarily on the curl of the wind stress components acting on the surface of the ocean. Calculations have been performed to estimate the wind stress over the surface of the ocean by computing mean geostrophic winds from pressure differences between grid points, applying a transformation to estimate surface winds and using a "square law" formula to relate wind speeds to surface stresses (Fofonoff, MS, 1960, 1961). The purpose of these calculations is two-fold. First, to find out how long an averaging period is necessary to approach steady-state conditions and second, to gain some idea of the variability, both with latitude and time, of the transport that is imposed on the ocean by the atmosphere.

Detailed descriptions of the method used for evaluating the transports are given in the introduction to the annual volumes of transport computations (Fofonoff, MS, 1960, 1961). The actual computer program for the calculation of mass transport is contained in the program manual M-1 (Fofonoff and Froese, Ms, 1960).

Six grid points in regions of special interest have been selected to evaluate the transport components for a given month in terms of mean values. They lie in the Gulf of Alaska (55° N, 155° W), Ocean Station "P" (average values at 50° N, 150° W and 50° N, 140° W), west of California Current (35° N, 135° W), adjacent to the Kuroshio Current (30° N, 160° E), the Oyashio Current (45° N, 155° E), and the Kamchatka Current (50° N, 160° E).

At each grid point the mean values and the standard deviations of the transport components from values for the same month from previous years are given in tabular form. In addition, the mean values of the integrated total and geostrophic transport for the month and eleven preceding months are given and compared with similar averages in previous years to indicate the long term trend of computed transport.

The departures of the monthly values from their means have been divided into three classes in terms of the number of standard deviations from the mean. The classes are:

Class 1: departure of less than one standard deviation from the mean (68% of values for a Gaussian distribution). Values falling in this range are termed "normal".

Class 2: departures of one to two standard deviations from the mean (17% of values for a Gaussian distribution). These values will be referred to as "above normal" or "below normal".

Class 3: departures greater than two standard deviations from the mean (5% of values for a Gaussian distribution). Values whose variation falls in this range will be denoted as "strongly above normal" or "strongly below normal".

### Transport charts

- I. Monthly mean sea-level atmospheric pressure given as the anomaly of mean atmospheric pressure from 1000 mbs. in units of 1/10 millibars.
- II. Meridional component of Ekman transport ( $V_E$ ) in units of 10 metric tons/km/sec.
- III. Zonal component of Ekman transport ( $U_E$ ) in units of 10 metric tons/km/sec.
- IV. Meridional component of total transport ( $V$ ) in units of 100 metric tons/km/sec.

The values shown on chart IV are  $-V$

- V. Integrated total transport ( $\Psi$ ) in units of 100,000 metric tons/sec.
- VI. Integrated geostrophic transport ( $\Psi_g$ ) in units of 100,000 metric tons/sec.

The convention of signs adopted is that northward and eastward transport shall be considered as positive and southward and westward flow shall be negative.

### References

- Fofonoff, N.P. MS, 1960. Transport computations for the North Pacific Ocean 1955-58. Fish. Res. Bd. Canada, MS Rept., Oceanogr. and Limnol. Series, Nos. 77-80, 93 pp.
- MS, 1961. Transport computations for the North Pacific Ocean 1959. Fish. Res. Bd. Canada, MS Rept., Oceanogr. and Limnol. Series, No. 85, 181 pp.
- Fofonoff, N.P., and C. Froese. MS, 1960. Programs for oceanographic computations and data processing on the electronic digital computer ALWAC III-E. M-1 miscellaneous programs. Fish. Res. Bd. Canada, MS Rept., Oceanogr. and Limnol. Series, No. 72, 35 pp.
- Munk, W.H. 1950. On the wind-driven ocean circulation. J. Meteorol. 1 (2), 79-93.
- Stommel, H. 1948. The westward intensification of wind-driven ocean currents. Trans. Amer. Geophys. Union 29, (2): 202-206.
- Sverdrup, H.V. 1947. Wind-driven currents in a baroclinic ocean; with applications to the equatorial currents of the Eastern Pacific. Proc. Nat. Acad. Sc., 33 (11): 318-326.

Assessment of transport calculations for September, 1961

The atmospheric pressure field showed the normal "high" and "low" pressure areas as being slightly more intense than usual for September. This gave rise to greater Ekman transport at all six grid points. All zonal components of Ekman transport were "strongly above normal" with the exception of Ocean Station "P" which, being situated near the centre of the "high" pressure area, only showed "above normal" transport. Meridional component of Ekman transport did not show as much of an increase. It was "normal" at Ocean Station "P" and in the Kuroshio Current, "above Normal" for the Kamchatka Current and in the Gulf of Alaska, and "strongly above normal" for the Oyashio and California Currents.

The meridional component of total transport was "normal" for each grid point except the Kuroshio Current which was "above normal" and the Oyashio and Kamchatka Currents which were "strongly below normal" and "strongly above normal" respectively.

The components of integrated transport were "normal" for the Gulf of Alaska and Ocean Station "P". The Oyashio and California Currents showed "above normal" and "below normal" components respectively. The integrated transports were "strongly below normal" for the Kamchatka Current. The integrated geostrophic transport was "above normal" for the Oyashio Current.

Trends of integrated transport were "below normal" for the Gulf of Alaska and "above normal" for the California Current and the integrated geostrophic component for Ocean Station "P".

Assessment of transport calculations for October, 1961

The atmospheric pressure pattern was typical for October. As usual a high pressure area developed over China.

Ekman transport components were "normal" for all grid points except the California and Kuroshio Current points where the zonal components were "above normal" and "strongly above normal" respectively.

The meridional component of total transport was "above normal" for the Kuroshio and California Currents. The other grid points had "normal" components.

Integrated transports and the trends of integrated transport were "normal" for all the selected grid points.

C.K. Ross

Table I. A comparison of transport components at selected grid points with the average values for the same month from previous years.

1. Kamchatka Current (50° N, 160° E)						4. Gulf of Alaska (55° N, 155° W)							
Sept 1961	Sept 1960	Sept Mean (55-60)	$\sigma$	$\frac{ x-\bar{x} }{\sigma}$	Class	Sept 1961	Sept 1960	Sept Mean (55-60)	$\sigma$	$\frac{ x-\bar{x} }{\sigma}$	Class		
$V_E$	-35	-19	-5.2	9.6	<u>3.11</u>	3	$V_E$	-35	-14	-12.2	10.8	<u>2.11</u>	3
$U_E$	18	17	-0.8	9.5	<u>1.98</u>	2	$U_E$	25	10	13.5	11.4	<u>1.01</u>	2
$-V$	-39	0	15.0	16.2	<u>3.33</u>	3	$-V$	-93	-76	-56.0	41.7	0.89	1
$\Psi$	-91	119	109.3	68.5	<u>2.93</u>	3	$\Psi$	57	58	44.0	21.0	0.62	1
$\Psi_g$	-70	132	120.2	65.8	<u>2.90</u>	3	$\Psi_g$	61	61	45.8	21.6	0.70	1
$\bar{\Psi}$	239.7	315.7	226.6	86.0	0.15	1	$\bar{\Psi}$	91.3	94.8	119.4	27.6	1.02	2
$\bar{\Psi}_g$	252.8	328.4	239.4	87.4	0.15	1	$\bar{\Psi}_g$	90.7	95.1	119.2	26.9	1.10	2

2. Oyashio (45° N, 155° E)						5. Ocean Station "P" (50° N, 145° W)							
Sept 1961	Sept 1960	Sept Mean (55-60)	$\sigma$	$\frac{ x-\bar{x} }{\sigma}$	Class	Sept 1961	Sept 1960	Sept Mean (55-60)	$\sigma$	$\frac{ x-\bar{x} }{\sigma}$	Class		
$V_E$	-35	-16	-2.8	7.0	<u>4.61</u>	3	$V_E$	-46.5	-32	-31.3	14.2	1.07	2
$U_E$	24	18	2.7	7.9	<u>2.70</u>	3	$U_E$	18.0	29	22.7	12.6	0.37	1
$-V$	27	22	5.0	10.9	<u>2.02</u>	3	$-V$	36.0	13	-1.2	40.7	0.91	1
$\Psi$	-202	-161	-50.7	126.1	<u>1.20</u>	2	$\Psi$	-22.5	-29	-4.8	33.2	0.53	1
$\Psi_g$	-187	-145	-35.0	126.6	<u>1.20</u>	2	$\Psi_g$	-18.5	-27	-2.3	34.4	0.47	1
$\bar{\Psi}$	91.3	83.6	66.2	41.3	0.61	1	$\bar{\Psi}$	50.3	36.2	35.8	17.0	0.85	1
$\bar{\Psi}_g$	120.9	118.0	94.8	44.4	0.59	1	$\bar{\Psi}_g$	56.7	39.2	38.4	16.8	1.09	1

3. Kurioshio (30° N, 140° E)						6. California Current (35° N, 135° W)							
Sept 1961	Sept 1960	Sept Mean (55-60)	$\sigma$	$\frac{ x-\bar{x} }{\sigma}$	Class	Sept 1961	Sept 1960	Sept Mean (55-60)	$\sigma$	$\frac{ x-\bar{x} }{\sigma}$	Class		
$V_E$	46	6	13.0	6.4	<u>5.16</u>	3	$V_E$	21	4	-1.3	5.7	<u>3.92</u>	3
$U_E$	16	1	10.8	7.9	0.66	1	$U_E$	-69	-36	-27.8	16.6	<u>2.48</u>	3
$-V$	38	11	8.2	17.1	1.74	2	$-V$	62	59	17.5	46.2	0.93	1
$\Psi$	-140	-293	-246.9	84.7	1.26	2	$\Psi$	-3	-14	-24.0	10.9	1.93	2
$\Psi_g$	-188	-321	-264.3	93.4	0.82	1	$\Psi_g$	-4	-14	-23.2	10.4	1.85	2
$\bar{\Psi}$	-326.7	-241.0	-292.3	53.0	0.65	1	$\bar{\Psi}$	-38.9	-24.7	-32.2	6.1	1.10	2
$\bar{\Psi}_g$	-325.3	-249.4	-296.6	48.3	0.59	1	$\bar{\Psi}_g$	-36.8	-23.8	-30.2	6.1	1.08	2

Explanation of tables:

$\frac{|x-\bar{x}|}{\sigma}$  is based on (55-60) values  
 $\sigma$  denotes deviation from mean in terms of standard deviation  
 $\bar{\Psi}, \bar{\Psi}_g$  are trends of integrated transports based on the straight mean of the month and the eleven preceding months.

Classes are explained on page 1-2.

Table II. A comparison of transport components at selected grid points with the average values for the same month from previous years.

1. Kamchatka Current (50° N, 160° E)						4. Gulf of Alaska (55° N, 155° W)							
Oct 1961	Oct 1960	Oct Mean (55-60)	$\sigma$	$\frac{ x-\bar{x} }{\sigma}$	Class	Oct 1961	Oct 1960	Oct Mean (55-60)	$\sigma$	$\frac{ x-\bar{x} }{\sigma}$	Class		
$V_E$	-38	-46	-36.7	19.8	0.07	1	$V_E$	-43	-12	-29.0	45.3	0.31	1
$U_E$	13	-6	1.5	19.6	0.59	1	$U_E$	-3	-1	-2.0	16.7	0.06	1
$-V$	-17	21	4.2	63.1	0.34	1	$-V$	-204	-87	-141.5	112.3	0.56	1
$\Psi$	-18	378	120.5	304.8	0.45	1	$\Psi$	222	130	177.2	133.7	0.34	1
$\Psi_3$	17	412	151.8	206.7	0.45	1	$\Psi_3$	227	131	180.0	137.6	0.34	1
$\overline{\Psi}_3$	206.7	331.3	229.4	82.0	0.28	1	$\overline{\Psi}_3$	99.0	101.5	116.2	35.4	0.49	1
$\Psi_3$	219.8	346.7	242.0	86.4	0.26	1	$\Psi_3$	98.7	101.9	115.8	35.1	0.49	1
2. Oyashio (45° N, 155° E)						5. Ocean Station "P" (50° N, 145° W)							
Oct 1961	Oct 1960	Oct Mean (55-60)	$\sigma$	$\frac{ x-\bar{x} }{\sigma}$	Class	Oct 1961	Oct 1960	Oct Mean (55-60)	$\sigma$	$\frac{ x-\bar{x} }{\sigma}$	Class		
$V_E$	-16	-7	-16.5	13.5	0.004	1	$V_E$	-108.5	-62	-75.8	65.5	0.50	1
$U_E$	7	-3	2.2	11.2	0.43	1	$U_E$	30.5	40	31.7	19.6	0.06	1
$-V$	43	28	27.7	23.8	0.64	1	$-V$	-13.0	-119	-43.5	44.1	0.69	1
$\Psi$	-314	-241	-157.3	292.4	0.54	1	$\Psi$	26.0	77	34.2	31.6	0.26	1
$\Psi_3$	-290	-196	-123.8	286.0	0.58	1	$\Psi_3$	34.5	82	40.3	35.2	0.16	1
$\overline{\Psi}_3$	85.3	35.5	66.6	48.4	0.39	1	$\overline{\Psi}_3$	46.0	42.5	36.4	19.2	0.50	1
$\Psi_3$	118.2	71.6	108.8	47.1	0.20	1	$\Psi_3$	52.8	45.8	39.0	19.6	0.70	1
3. Kuroshio (30° N, 140° E)						6. California Current (35° N, 135° W)							
Oct 1961	Oct 1960	Oct Mean (55-60)	$\sigma$	$\frac{ x-\bar{x} }{\sigma}$	Class	Oct 1961	Oct 1960	Oct Mean (55-60)	$\sigma$	$\frac{ x-\bar{x} }{\sigma}$	Class		
$V_E$	81	73	37.7	20.5	<u>2.11</u>	3	$V_E$	2	-11	-6.8	4.6	1.91	2
$U_E$	-18	-35	-11.5	12.1	0.54	1	$U_E$	-27	-5	-7.5	23.5	0.83	1
$-V$	-51	-44	-6.7	27.1	1.63	2	$-V$	55	36	12.3	28.8	1.48	2
$\Psi$	-230	-216	-206.8	75.4	0.31	1	$\Psi$	-15	-21	-15.7	9.6	0.07	1
$\Psi_3$	-285	-236	-231.5	81.9	0.65	1	$\Psi_3$	-15	-20	-15.2	9.4	0.02	1
$\overline{\Psi}_3$	-326.7	-246.6	-290.0	53.5	0.69	1	$\overline{\Psi}_3$	-38.4	-25.1	-32.2	6.6	0.94	1
$\Psi_3$	-329.3	-256.6	-294.4	50.4	0.69	1	$\Psi_3$	-36.3	-24.1	-30.4	6.8	0.87	1

Explanation of table - see Table I.

Sep 1 Sep 30 1961

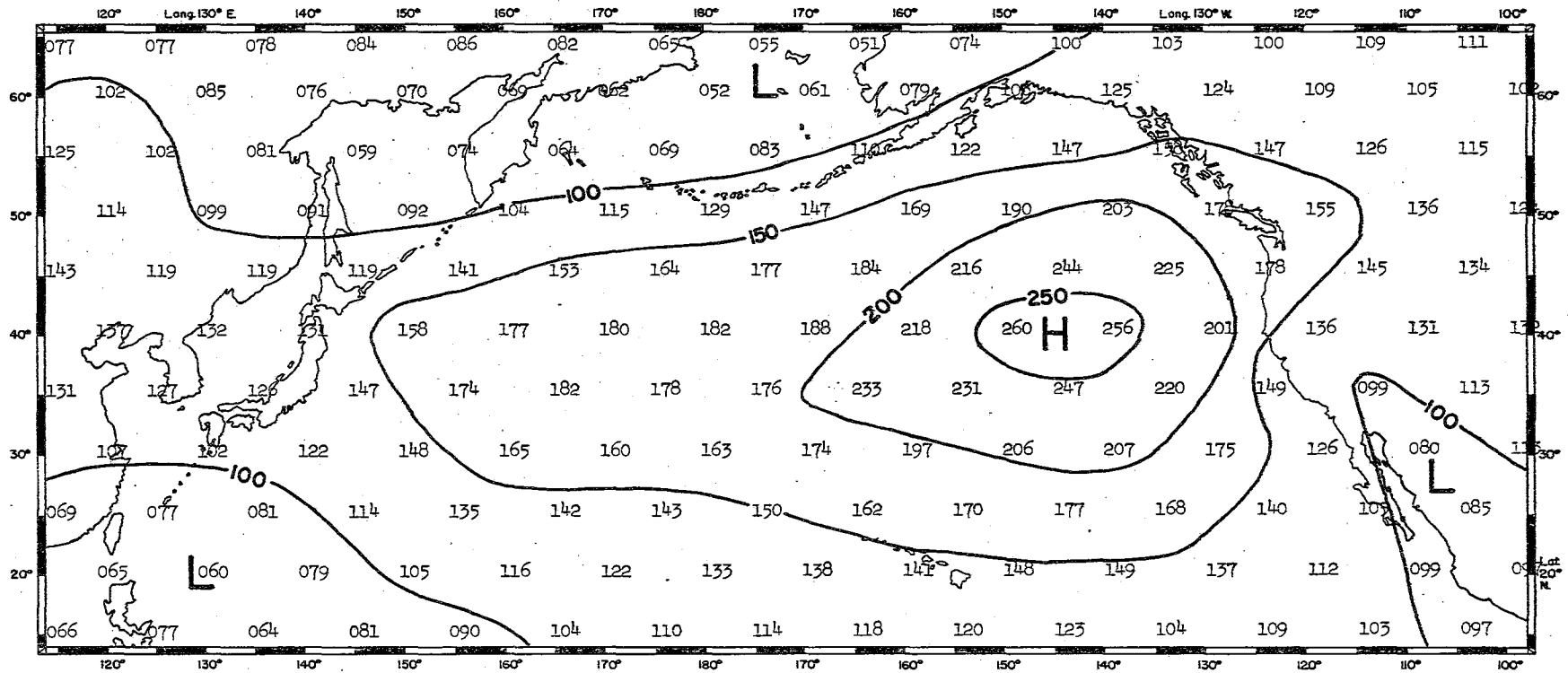

I. Atmospheric Pressure

Sep 1 Sept 30 1961

Sep 1 Sep 30 1961

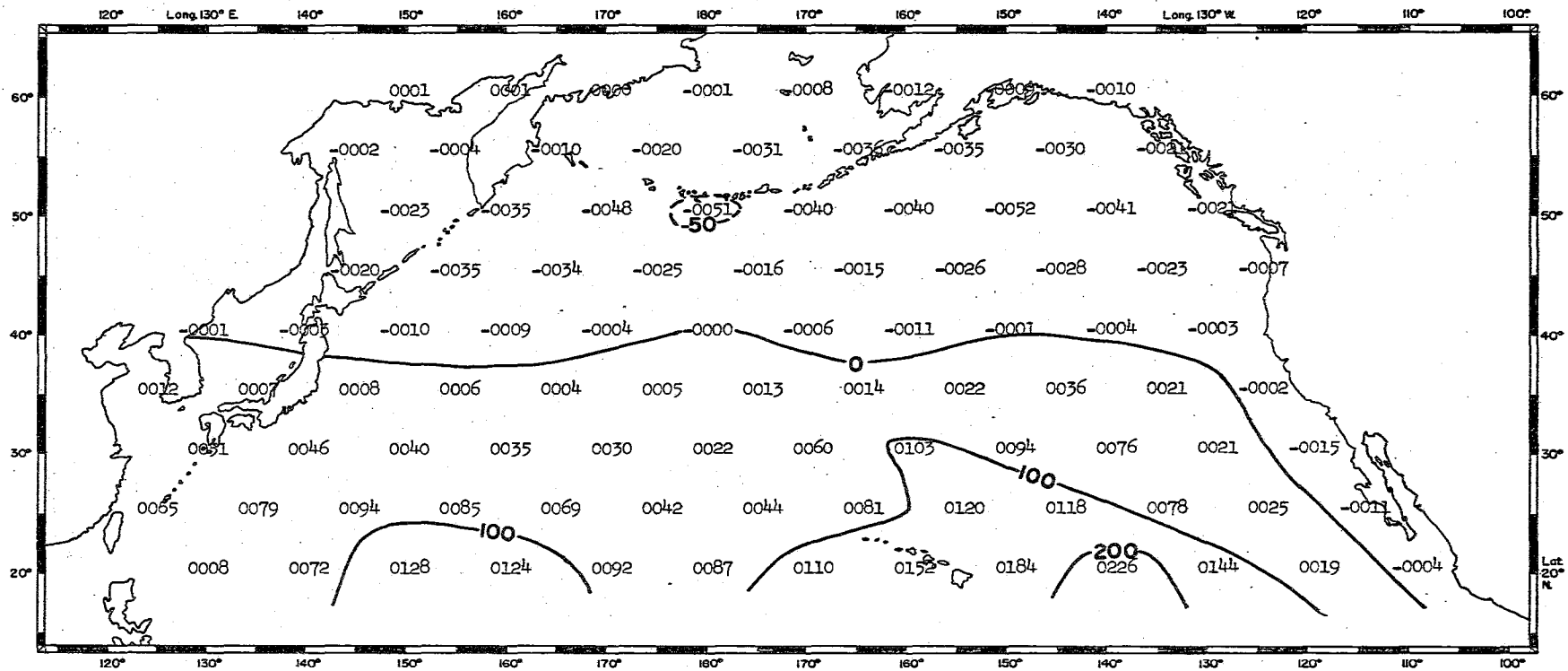

II. Meridional Component of Ekman Transport

Sep 1 Sep 30 1961

Sep 1 Sep 30 1961

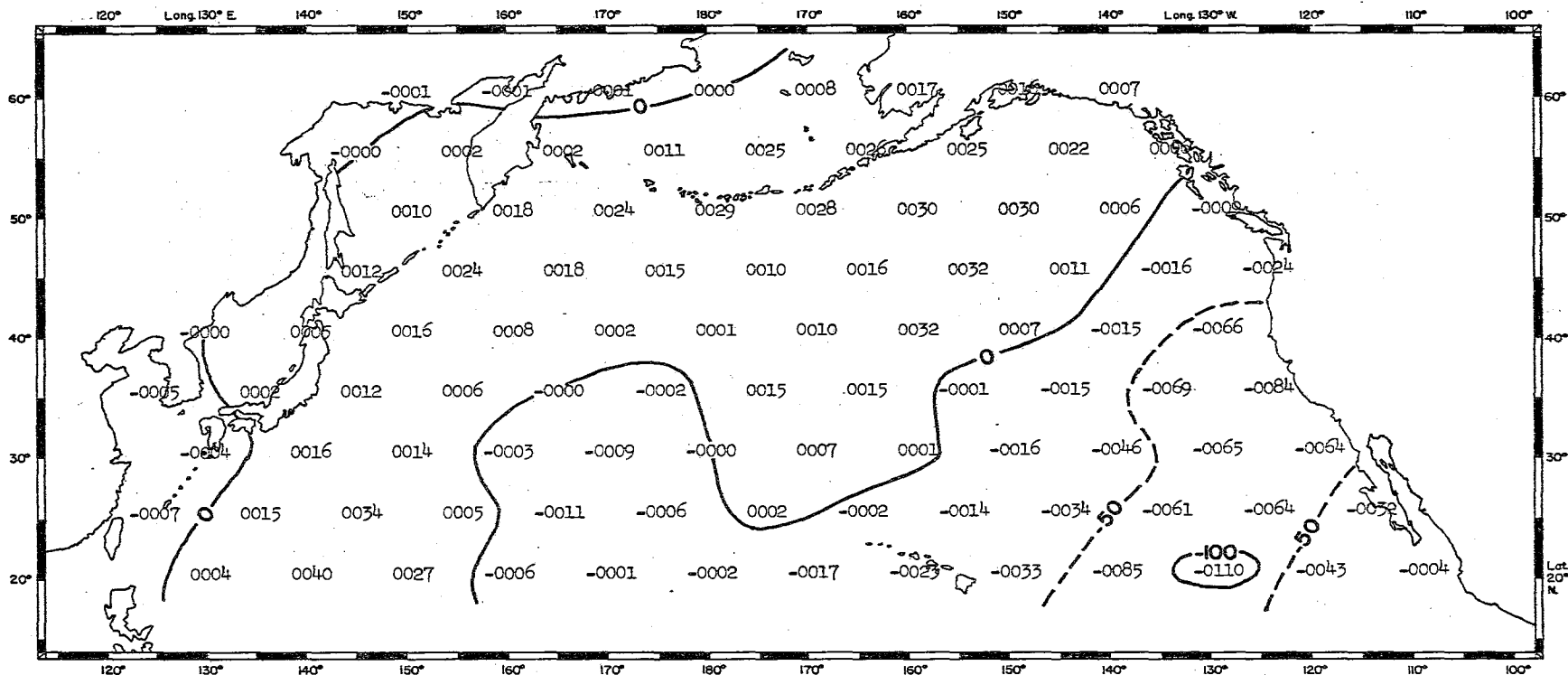

III. Zonal Component of Ekman Transport

Sep 1 Sep 30 1961

Sep 1 Sep 30 1961

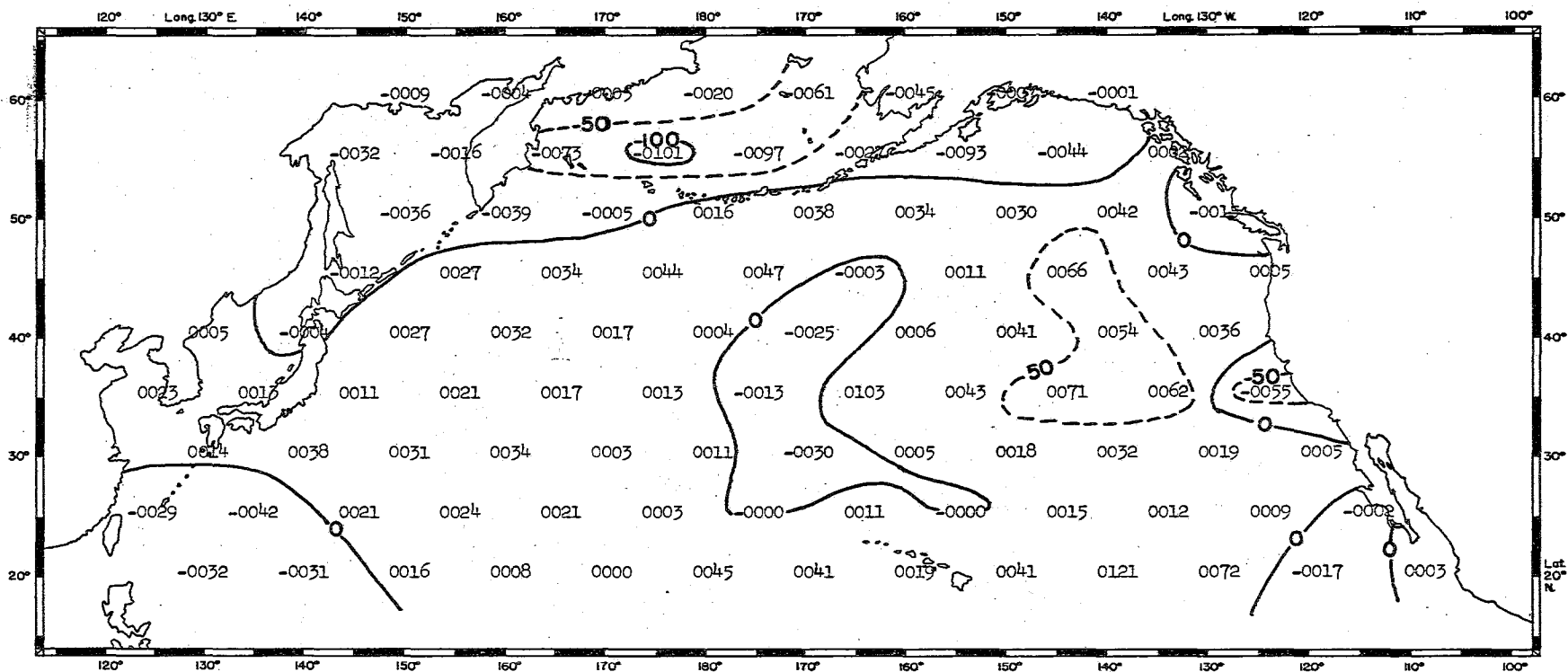

IV. Meridional Component of Total Transport

Sep 1 Sep 30 1961

Sep 1 Sep 30 1961

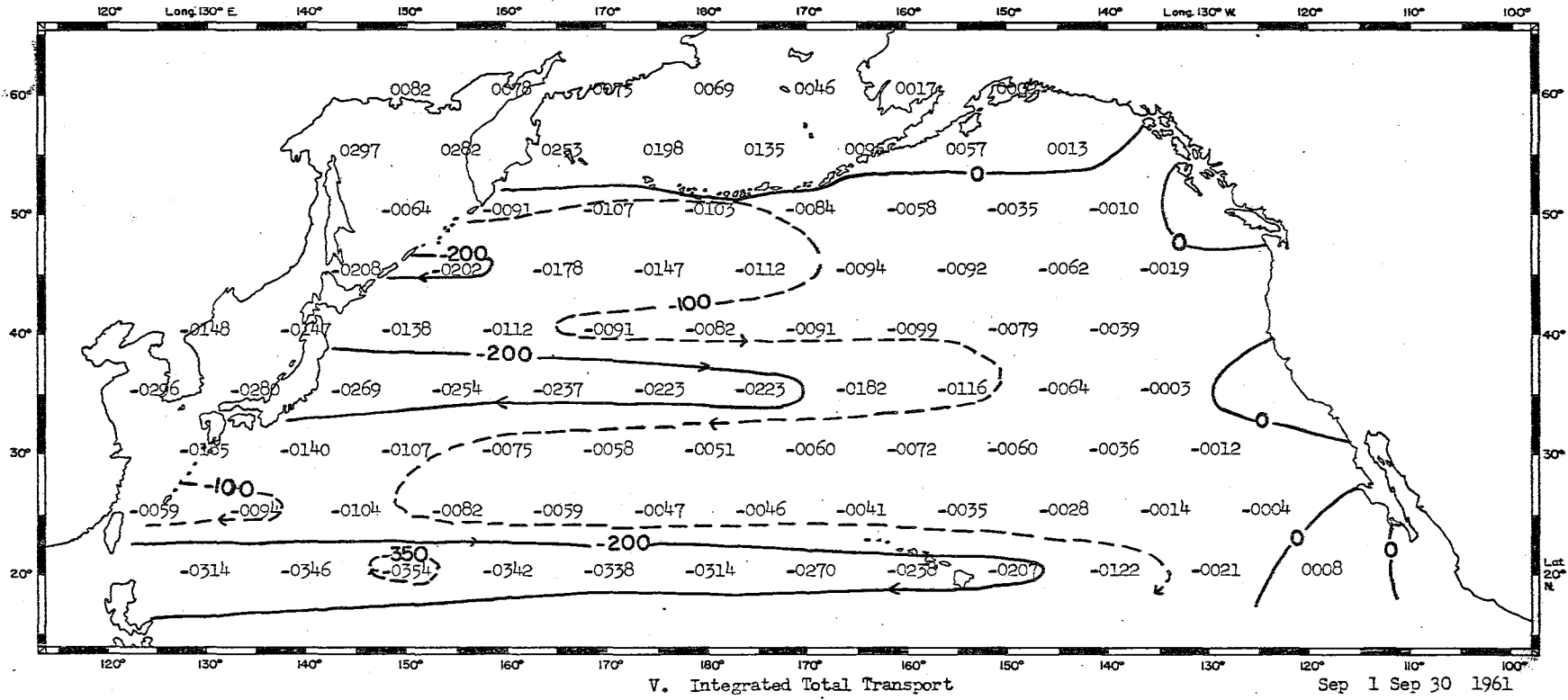

Sep 1 Sep 30 1961

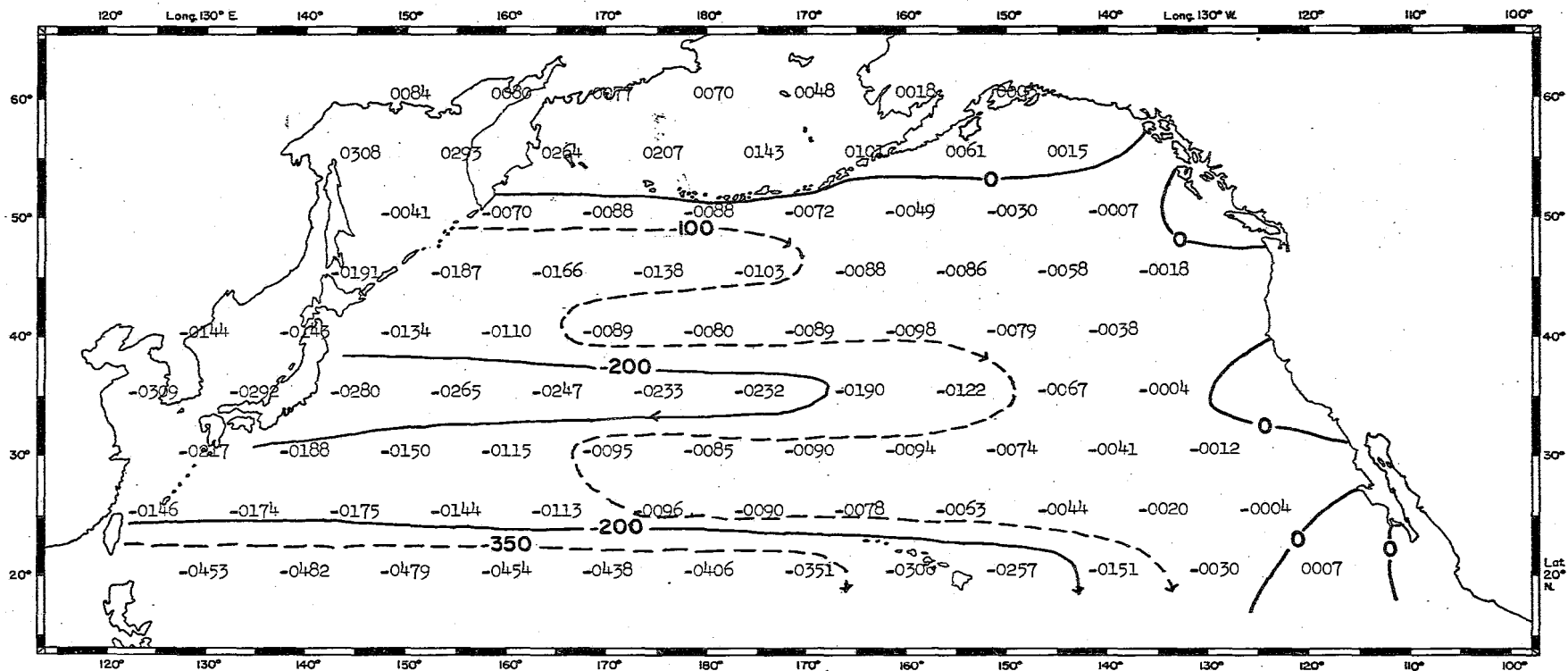

VI. Integrated Geostrophic Transport

Sep 1 Sep 30 1961

Lat  
20°  
N

Oct 1 Oct 30 1961

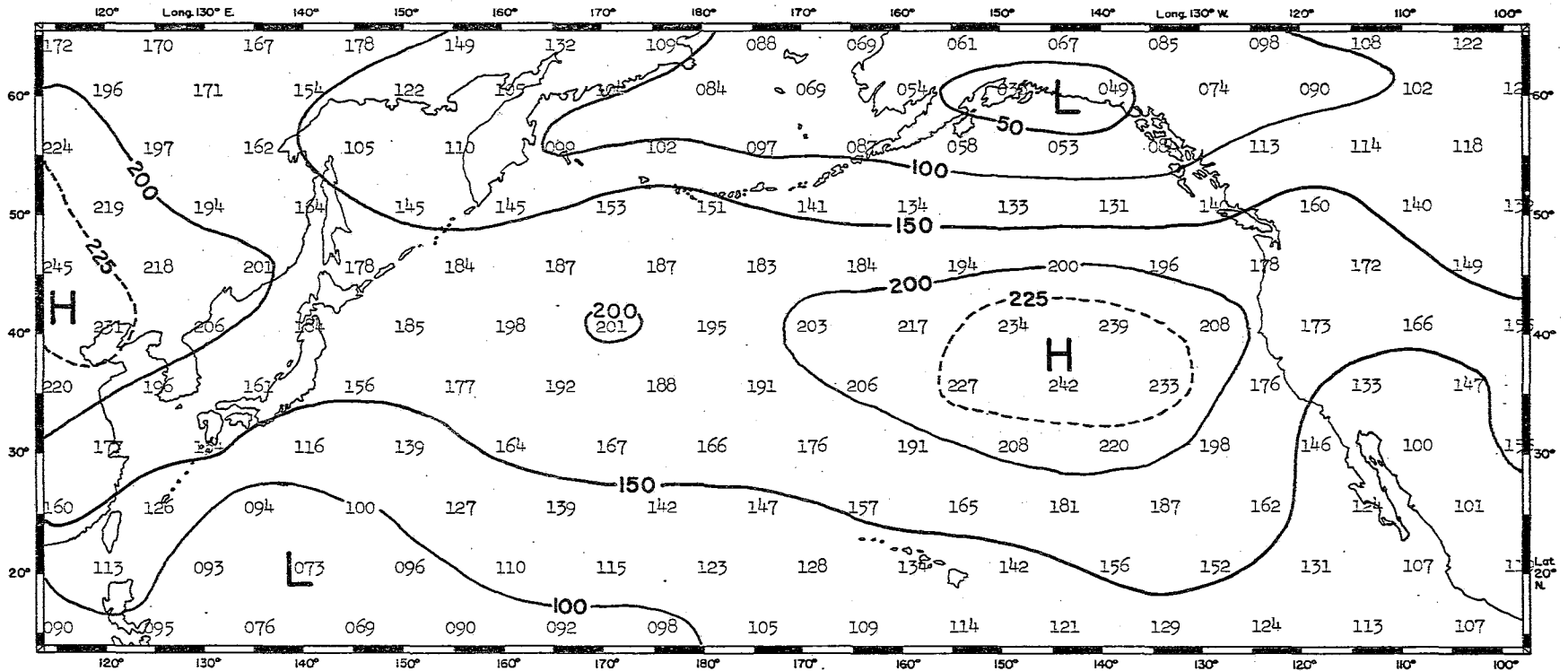

I. Atmospheric Pressure

Oct 1 Oct 30 1961

Oct 1 Oct 30 1961

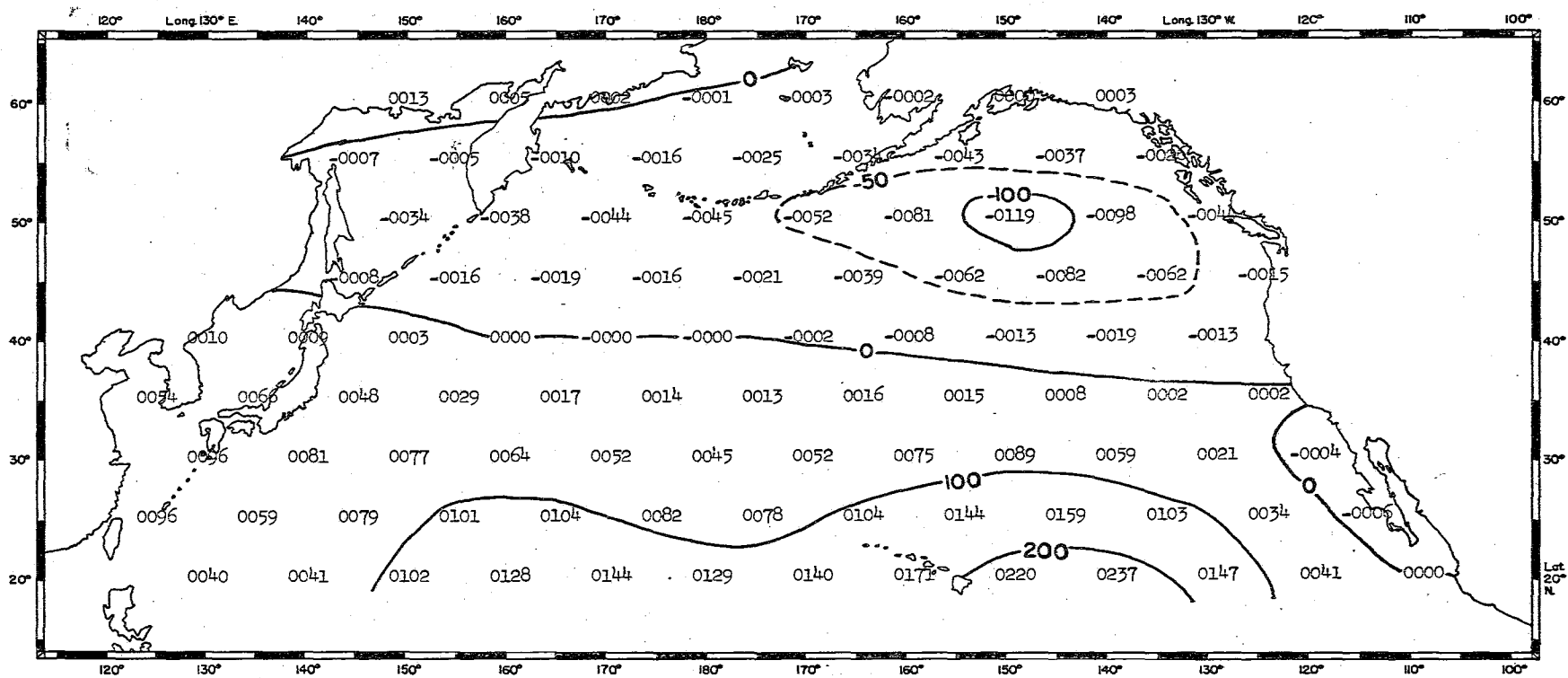

II. Meridional Component of Ekman Transport

Oct 1 Oct 30 1961

Oct 1 Oct 30 1961

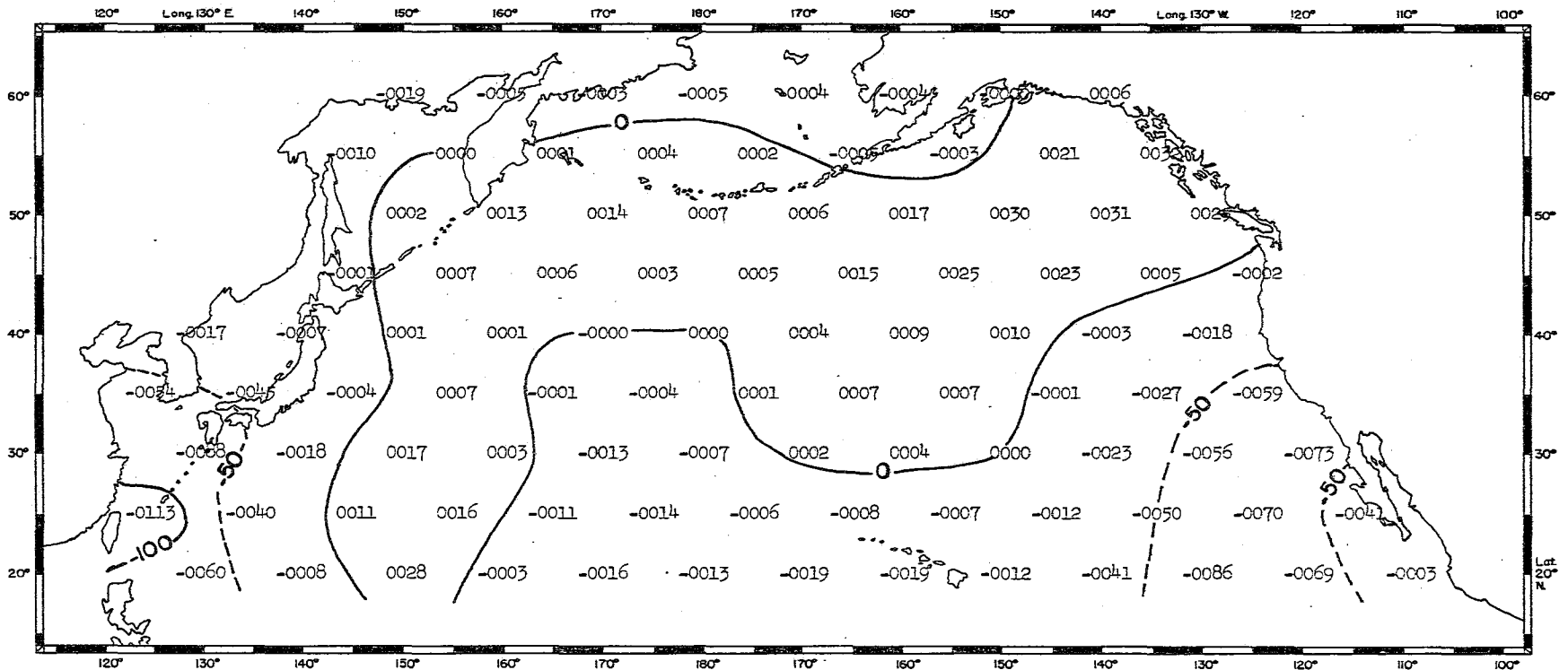

III. Zonal Component of Ekman Transport

Oct 1 Oct 30 1961

Oct 1 Oct 30 1961

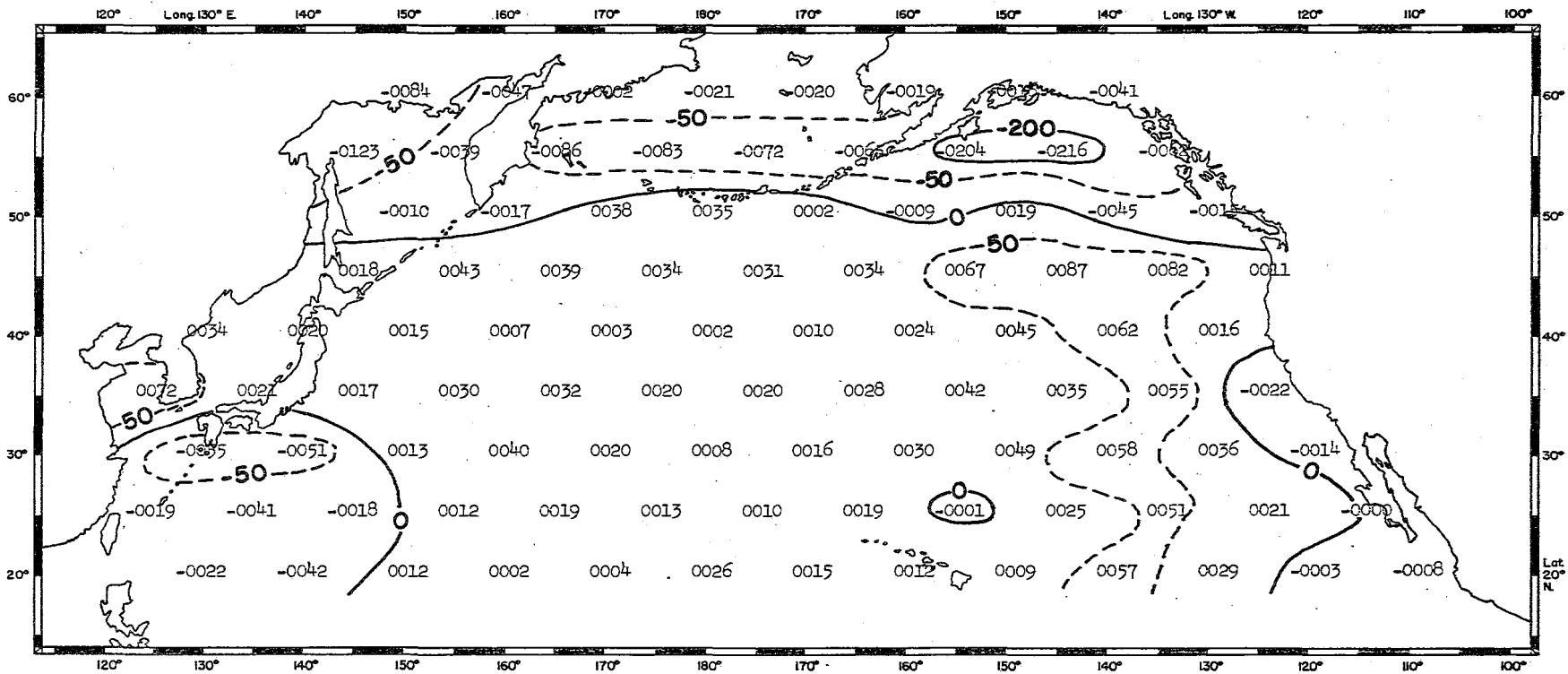

IV. Meridional Component of Total Transport

Oct 1 Oct 30 1961

Oct 1 Oct 30 1961

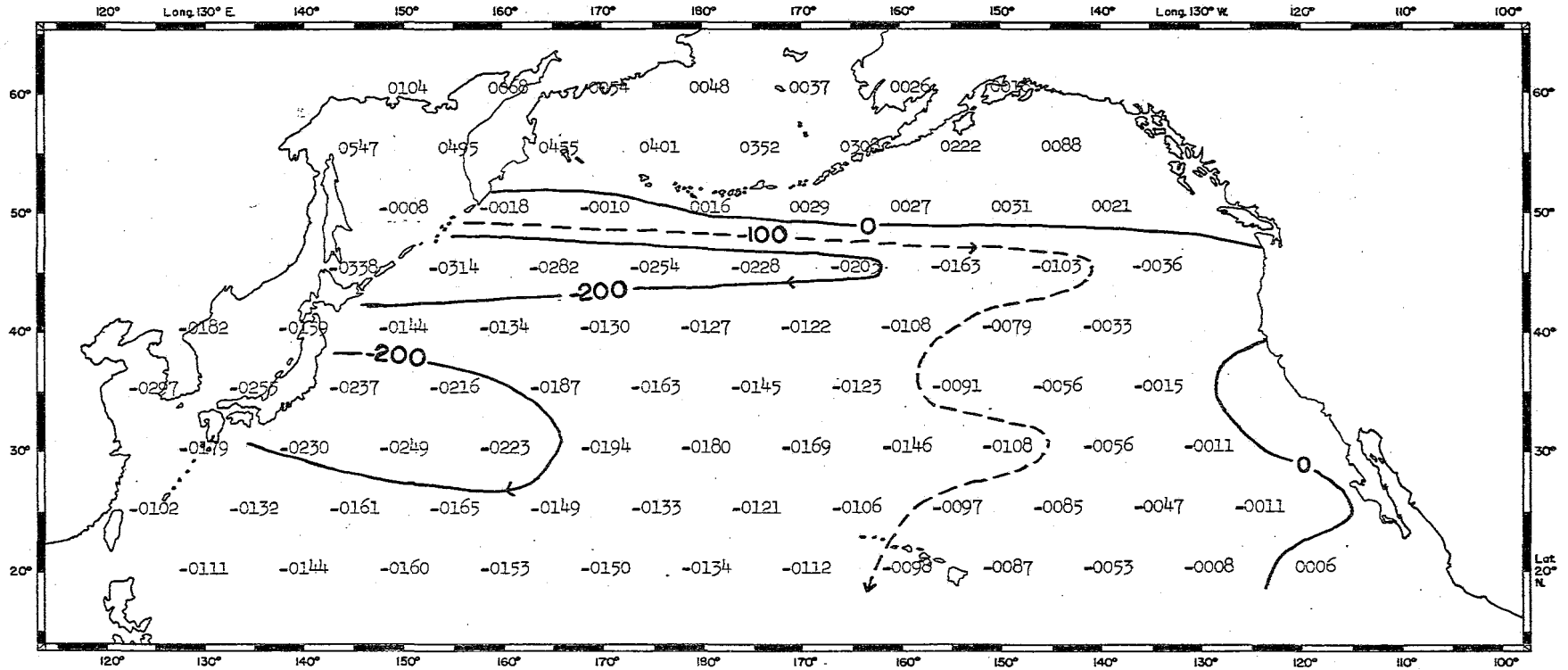

V. Integrated Total Transport

Oct 1 Oct 30 1961

Oct 1 Oct 30 1961

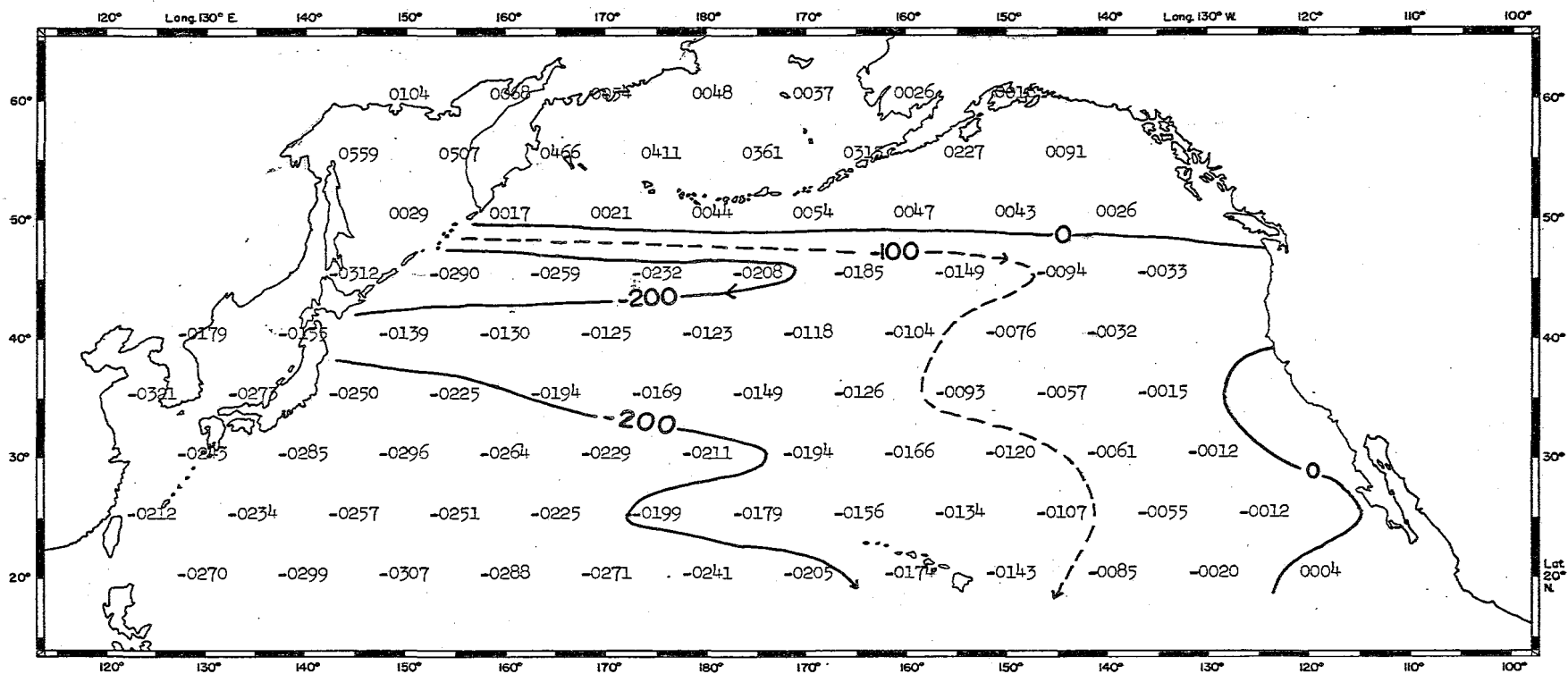

VI. Integrated Geostrophic Transport

Oct 1 Oct 30 1961

### MERIDIONAL COMPONENT OF EKMAN TRANSPORT in 10 metric tons/second/kilometer

FIG. 1

---- 1960

⊥ (1955-60) mean ± σ

---+--- 1961

1. KAMCHATKA CURRENT (50°N, 160°E)

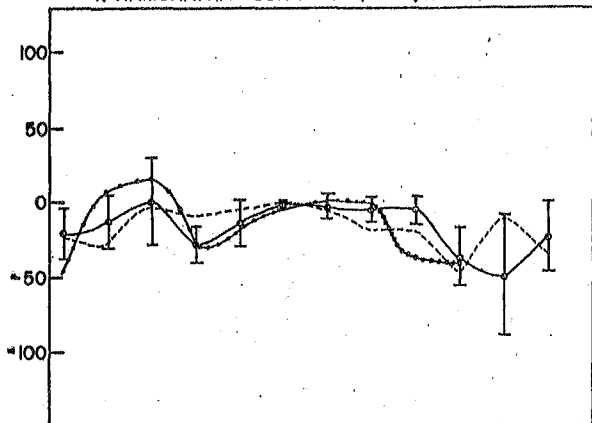

4. GULF OF ALASKA (55°N, 155°W)

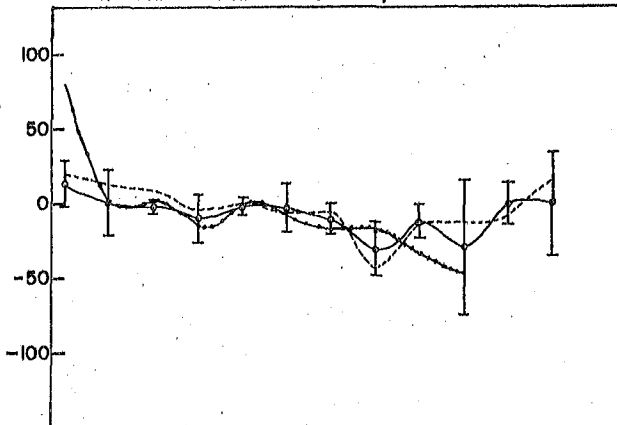

2. OYASHIO CURRENT (45°N, 155°E)

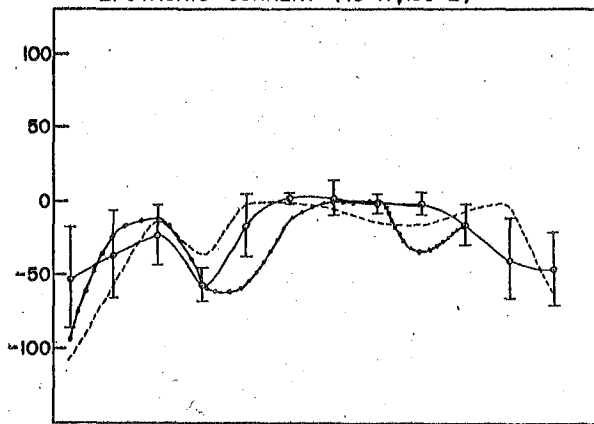

5. OCEAN STATION "P" (50°N, 145°W)

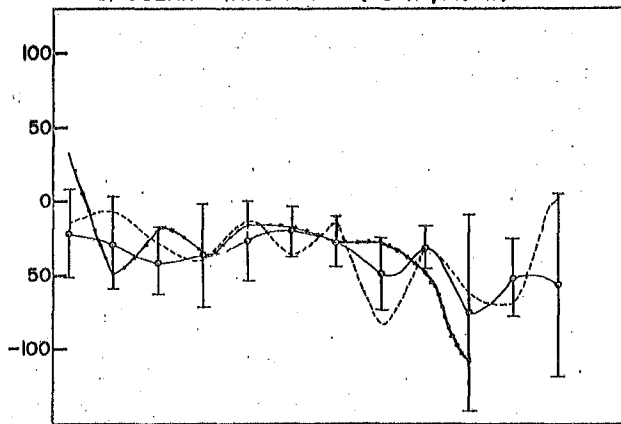

3. KUROSHIO CURRENT (30°N, 140°E)

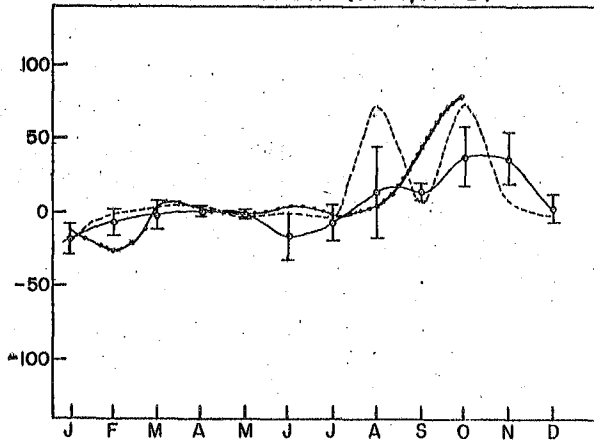

6. CALIFORNIA CURRENT (35°N, 135°W)

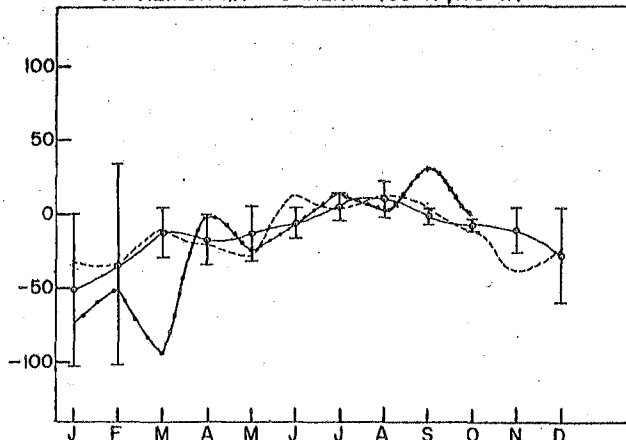

**FIG 2** ZONAL COMPONENT OF EKMAN TRANSPORT  
in 10 metric tons / second / kilometer

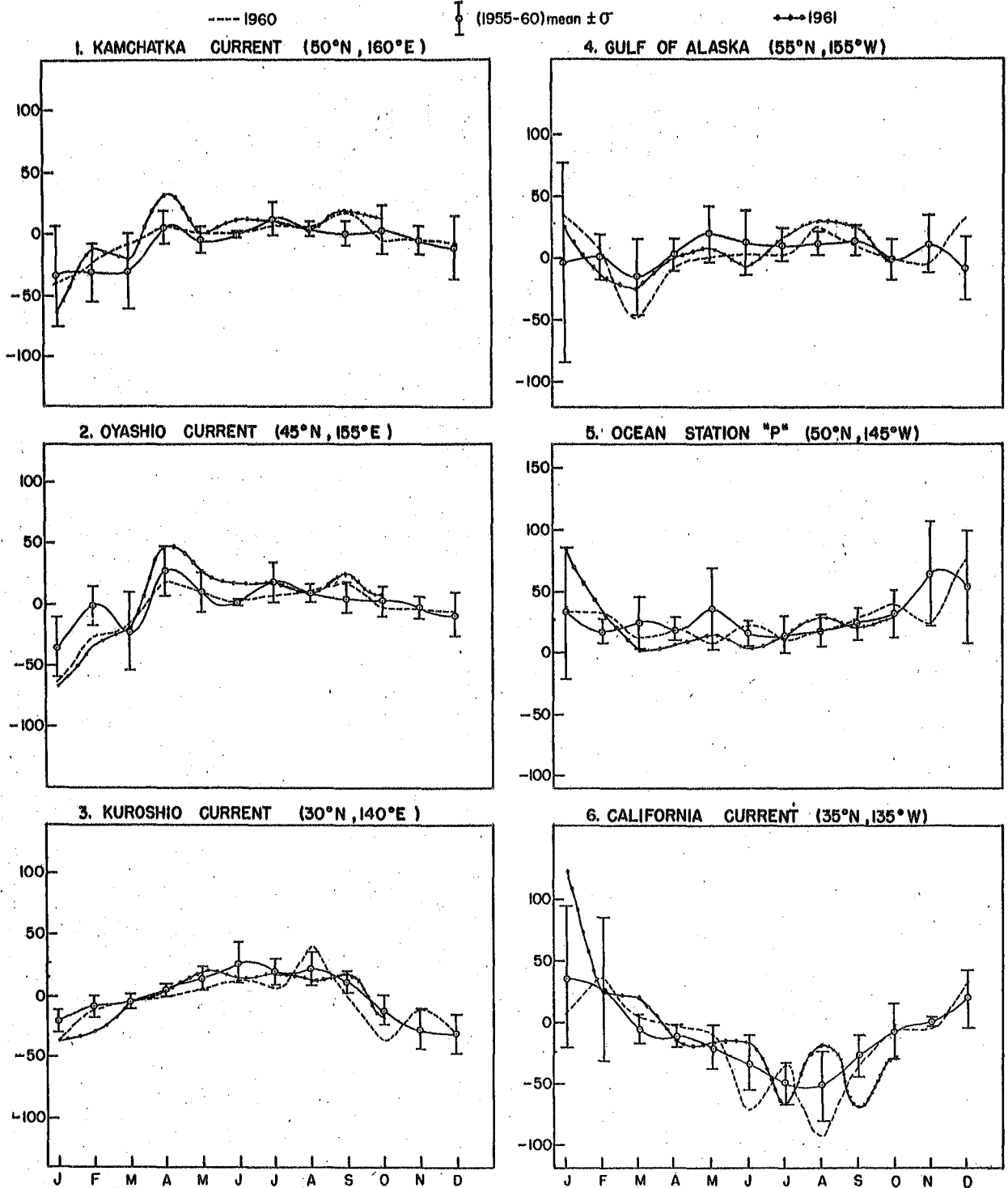

**FIG. 3** MERIDIONAL COMPONENT OF TOTAL TRANSPORT  
100 metric tons/second/kilometre

----- 1960

○ (1955-60) mean ±  $\sigma$

----- 1961

**1. KAMCHATKA CURRENT (50°N, 160°E)**

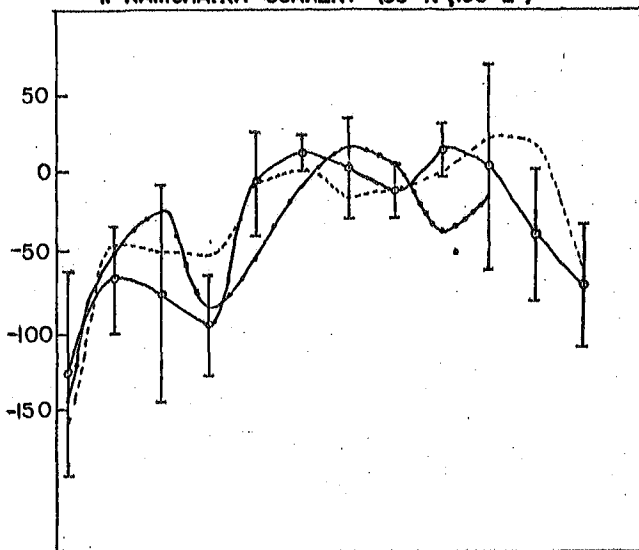

**4. GULF OF ALASKA (55°N, 155°W)**

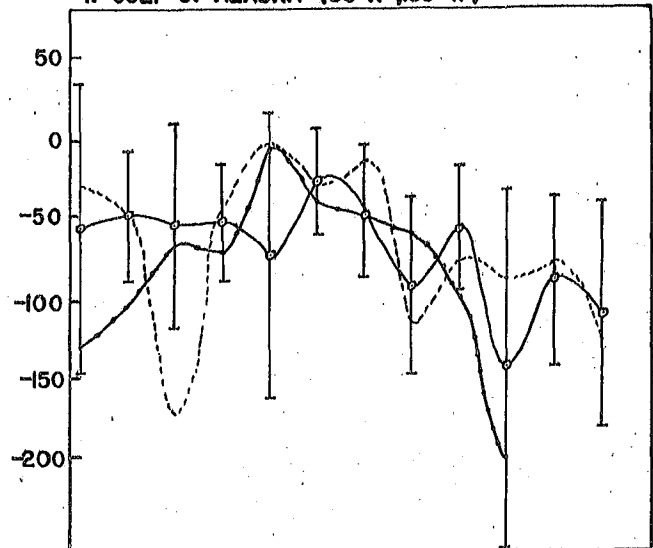

**2. OYASHIO CURRENT (45°N, 155°E)**

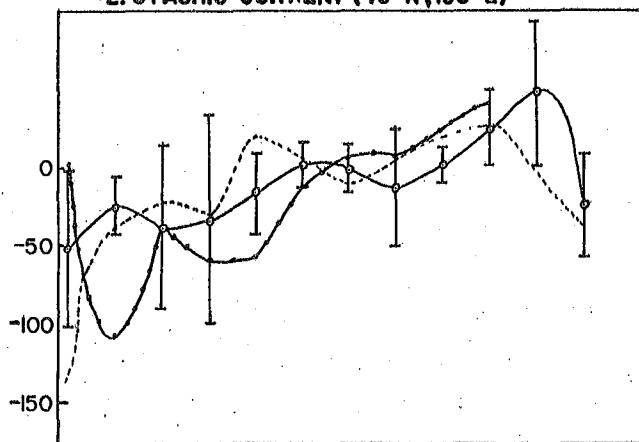

**5. OCEAN STATION "P" (50°N, 145°W)**

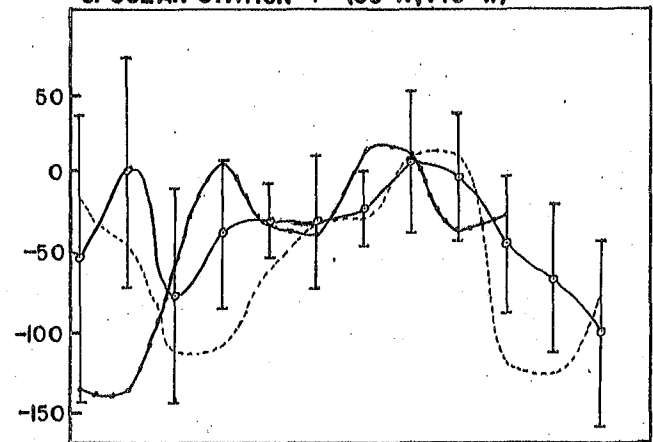

**3. KUROSHIO CURRENT (30°N, 140°E)**

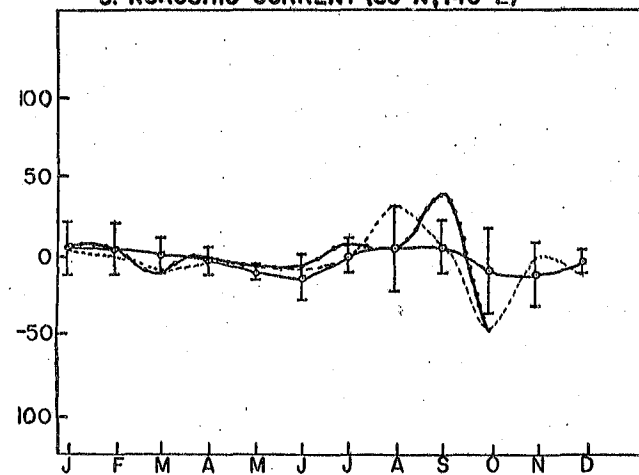

**6. CALIFORNIA CURRENT (35°N, 135°W)**

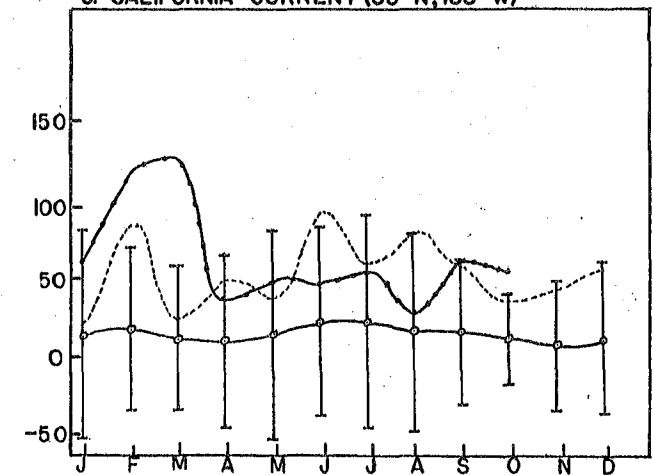
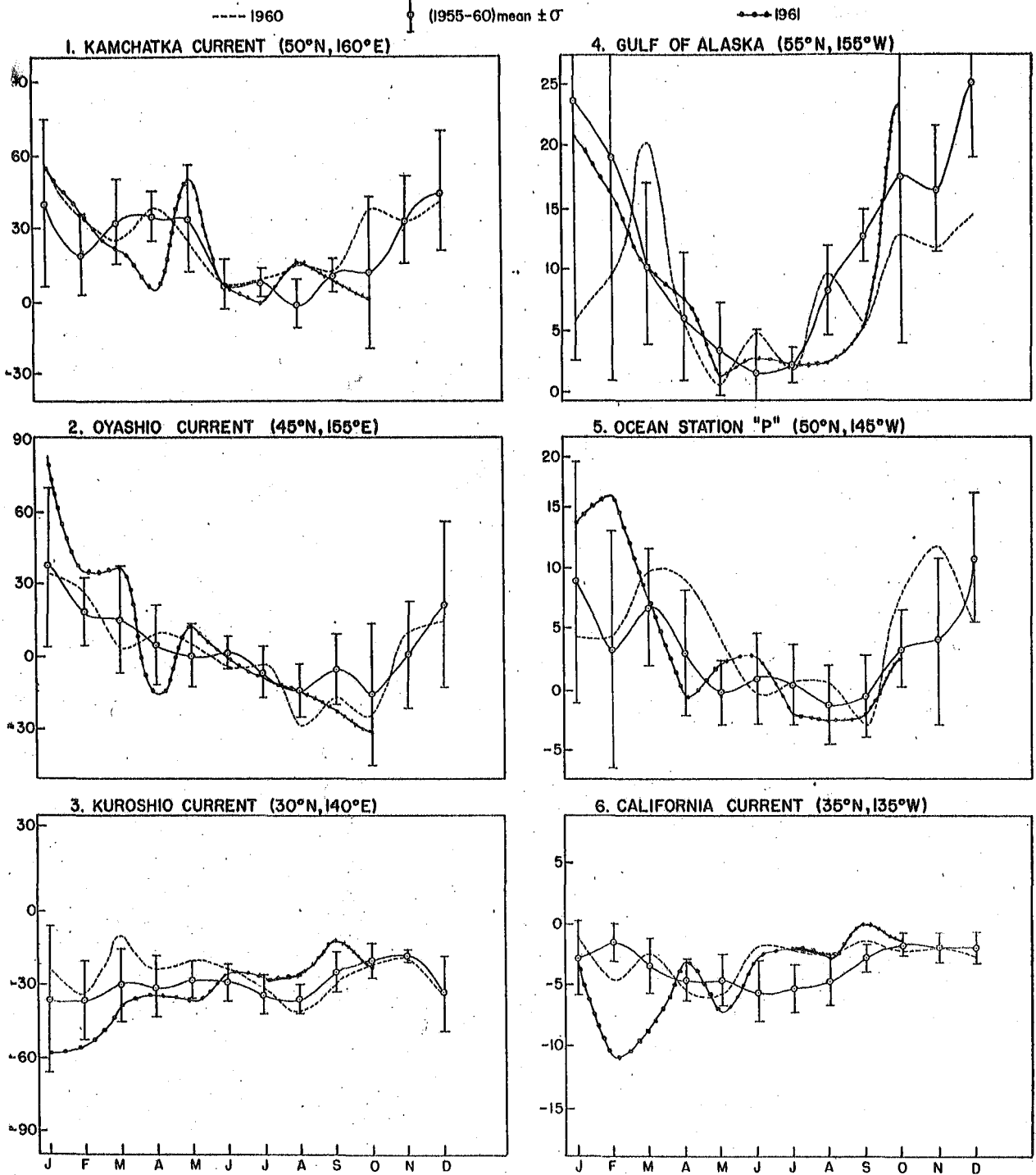

FIG. 4 INTEGRATED TOTAL TRANSPORT  
in millions of metric tons /second.



**FIG 5** INTEGRATED GEOSTROPHIC TRANSPORT  
in millions of metric tons/second

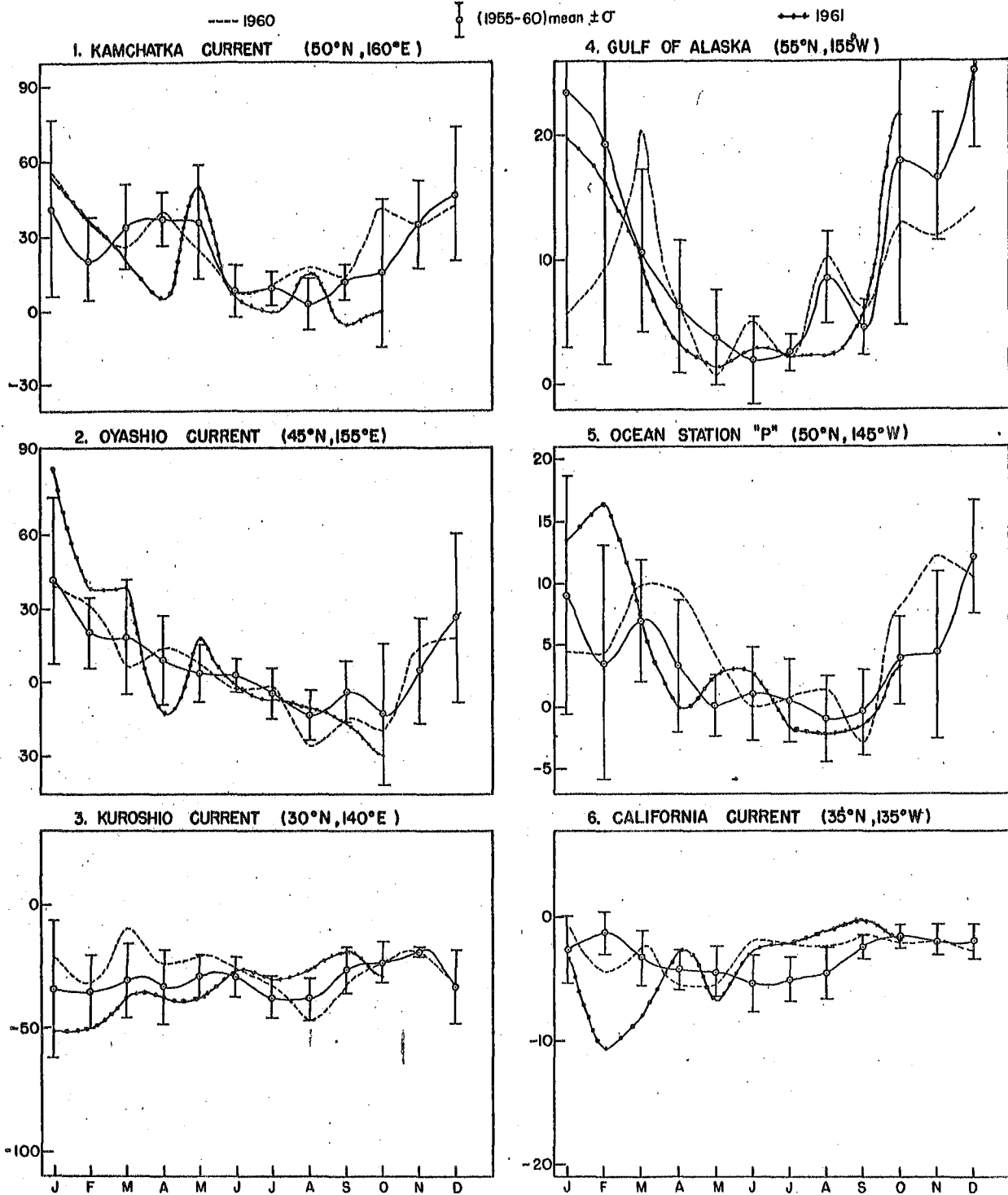

FIG. 6 TREND OF INTEGRATED TOTAL TRANSPORT  
in millions of metric tons/second

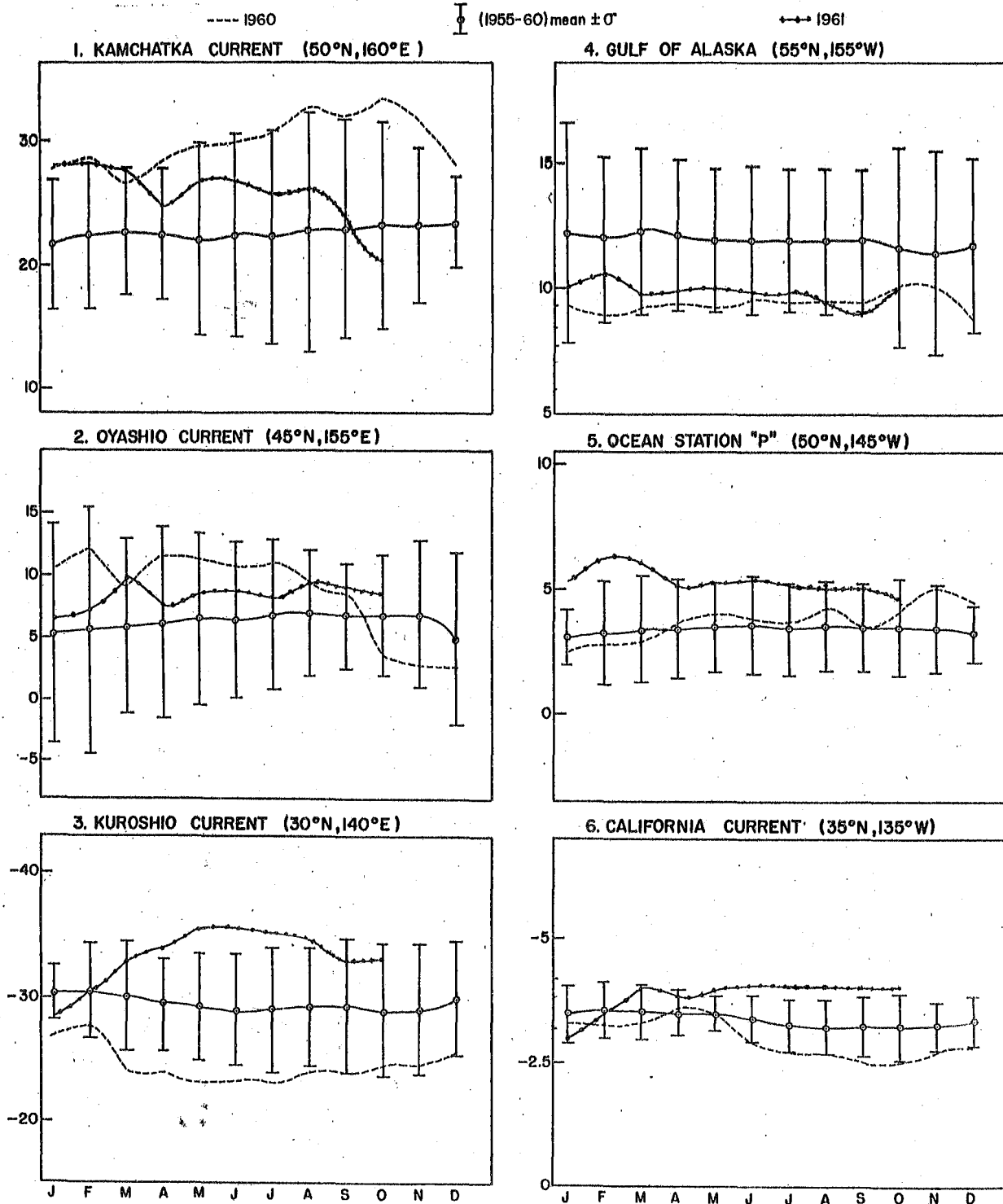
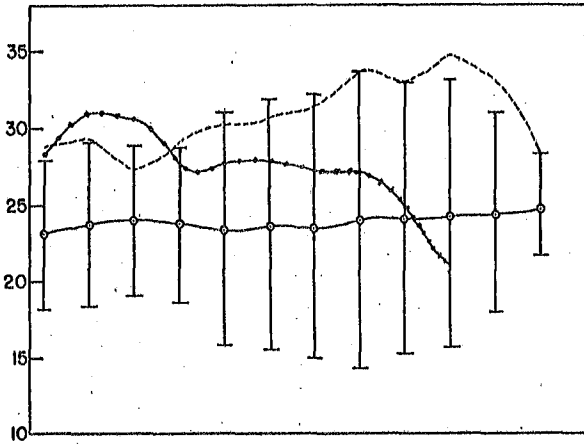

FIG. 7 TREND OF INTEGRATED GEOSTROPHIC TRANSPORT  
in millions of metric tons / second

----- 1960 (1955-60) mean  $\pm$   $\sigma$  1961

1. KAMCHATKA CURRENT (50°N, 160°E)



4. GULF OF ALASKA (55°N, 155°W)

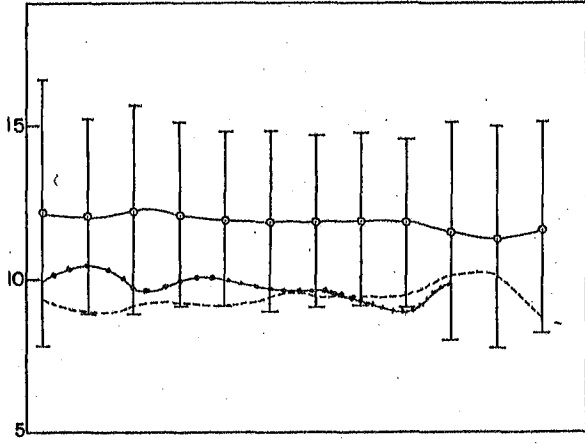

2. OYASHIO CURRENT (45°N, 160°E)

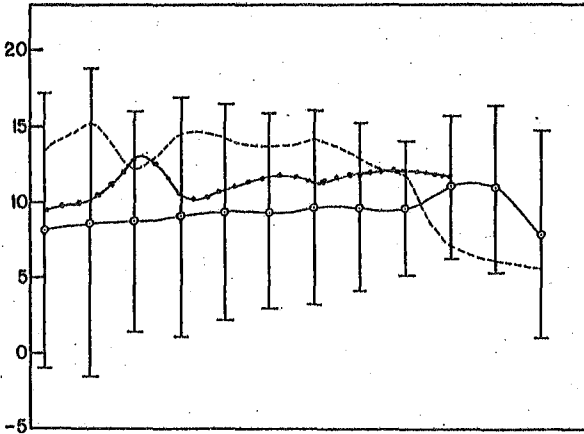

5. OCEAN STATION "P" (50°N, 145°W)

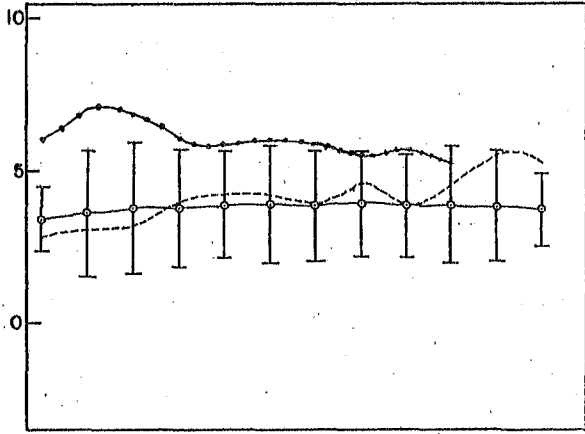

3. KUROSHIO CURRENT (30°N, 140°E)

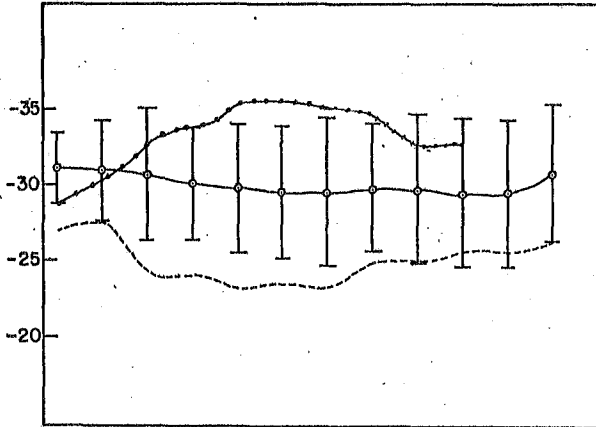

6. CALIFORNIA CURRENT (35°N, 135°W)

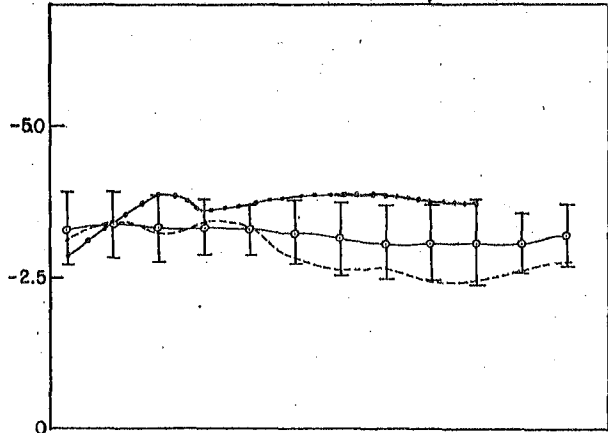

FISHERIES RESEARCH BOARD OF CANADA  
Pacific Oceanographic Group  
Nanaimo, B. C.

Circular 1962 -3  
January 23, 1962

B.C. Coastal Seawater Temperatures  
November and December, 1961

Introduction

The data presented in this circular were obtained from weekly radio reports of daily seawater temperatures observed at four lightstations - Triple Island, McInnes Island, Amphitrite Point, and Entrance Island; and from monthly reports of daily temperatures at Langara Island, Cape St. James, and Quatsino (Kains Island) lightstations. These latter reports are forwarded to the San Diego Biological Laboratory of the U.S. Bureau of Commercial Fisheries for use in their monthly sea-surface temperature charts of the eastern Pacific Ocean.

This circular is a summary of the data for the two months of November and December, 1961.

The data are tabulated in Table I as monthly average temperatures. The classification indices recorded in the last column of Table I represent the number of  $\frac{1}{2}$  standard deviation units that the monthly mean differs from 10-year grand monthly mean (+ is a warmer anomaly; - is a colder anomaly).

Seawater temperature conditions in the Hecate Strait region

At McInnes and Triple Islands, the seawater temperatures cooled off quite steadily during November and into the first part of December. Then, there was very little cooling at McInnes for the remainder of the month, but at Triple it continued at the rate of 1 F° each week. This monthly variation in cooling rates is shown in Table I by the fact that the November-October temperature anomalies for both stations were greater than those for December-November. In November, the monthly mean temperatures at McInnes and Triple were  $1\frac{1}{2}$  F° colder than in 1960, whilst in December this colder anomaly had increased to  $2\frac{1}{2}$  F° at the former and to 2 F° at the latter station. The increasing cool trend at Triple is also shown by the change of the classification indices from -2 to -3.

Seawater temperature conditions along the ocean coasts

Monthly average temperatures at Langara Island were slightly colder than average during both months. The rate of cooling was  $2\frac{1}{2}$  F° per month (Table I). Temperatures at Langara are slightly cooler than at the other three oceanic stations, - Cape St. James, Kains and Amphitrite. At these

three stations the November monthly average was 47° F, and the December average was 45° F. The temperatures at Cape St. James in November were about average and were the same as in 1960. December temperatures were colder than in 1960 and also colder than average.

Temperatures at Kains Island and Amphitrite Point were significantly colder than average for both months. The classification indices were -2 and -3, whereas those for Langara and Cape St. James were only -1. U.S. Bureau of Commercial Fisheries ocean temperature charts for November and December show a region of cold temperature anomalies adjacent to the Vancouver Island coast. Weekly average temperatures at Amphitrite during November were as much as 5 F° colder than at the same time in 1960, when there were warmer than average temperatures.

#### Seawater temperature conditions in Georgia Strait

The same colder-than-average temperature conditions were also noted in the temperature records from Entrance Island and Departure Bay. Temperatures at the latter station had the larger anomalies. November temperatures were 4 F° colder than in October, and December temperatures were about 3 F° colder than in November. The difference with 1960 temperatures was not as large as at most of the other observing stations. Temperatures in December were more anomalous to average conditions than those in November.

#### General summary

B.C. coastal seawater temperatures observed at the eight stations (Table I) for November and December were colder than average in all instances except one. The monthly mean temperatures were colder than those observed in 1960, especially at Amphitrite Point. The cold anomalous condition was greater in December than in November. Records from Kains and Amphitrite indicate that a region of colder-than-usual ocean temperature was present off the west coast of Vancouver Island.

H. J. Hollister.

Table I. Monthly means of seawater temperatures (°F)  
November and December, 1961

Station	Nov. 1961	Nov.- Oct.	Nov. diff. 1961-1960	Nov. 1961- 10 yr. av'ge.	Classific'n/ Std. dev'n
Langara I.	46.5*	-2.8	-0.8	-1.1	-1/1.5
Cape St. James	47.2*	-2.9	+0.1	+0.1	+0/1.3
Triple I.	46.2	-3.7	-1.4	-1.5	-2/1.2
McInnes I.	46.1	-4.7	-1.5	-0.3**	-
Kains I.	47.2	-3.5	-2.0	-1.9	-2/1.4
Amphitrite Pt.	47.1	-3.6	-4.9	-2.7	-2/1.9
Entrance I.	47.6	-3.9	-0.8	-0.3	-0/1.0
Departure Bay	46.9	-4.5	-0.4	-0.5	-1/1.1

Station	Dec. 1961	Dec.- Nov.	Dec. diff. 1961-1960	Dec. 1961- 10 yr. av'ge.	Classific'n/ Std. dev'n
Langara I.	43.9*	-2.6	-1.7	-1.0	-1/1.3
Cape St. James	45.1*	-2.1	-1.9	-0.9	-1/1.2
Triple I.	43.5	-2.7	-2.5	-2.5	-3/1.5
McInnes I.	44.2	-1.9	-1.9	-0.8**	-
Kains I.	44.9*	-2.3	-2.6	-2.1	-2/1.6
Amphitrite Pt.	45.0	-2.1	-3.7	-2.5	-3/1.6
Entrance I.	45.1	-2.5	-0.3	-0.6	-1/1.0
Departure Bay	43.5	-3.4	-1.3	-1.1	-2/0.9

\*1-27 mean

\*\*7-yr. av'ge.

*Dr. Neudler*

FISHERIES RESEARCH BOARD OF CANADA  
Pacific Oceanographic Group  
Nanaimo, B. C.

Circular 1962 - 4  
February 7, 1962

Transport calculations for the North Pacific Ocean  
November 1961

Sverdrup (1947), Stommel (1948), and Munk (1950) have shown that the total steady-state transport of mass in the ocean depends primarily on the curl of the wind stress components acting on the surface of the ocean. Calculations have been performed to estimate the wind stress over the surface of the ocean by computing mean geostrophic winds from pressure differences between grid points, applying a transformation to estimate surface winds and using a "square law" formula to relate wind speeds to surface stresses (Fofonoff, MS, 1960, 1961). The purpose of these calculations is two-fold. First, to find out how long an averaging period is necessary to approach steady-state conditions and second, to gain some idea of the variability, both with latitude and time, of the transport that is imposed on the ocean by the atmosphere.

Detailed descriptions of the method used for evaluating the transports are given in the introduction to the annual volumes of transport computations (Fofonoff, MS, 1960, 1961). The actual computer program for the calculation of mass transport is contained in the program manual M-1 (Fofonoff and Froese, Ms, 1960).

Six grid points in regions of special interest have been selected to evaluate the transport components for a given month in terms of mean values. They lie in the Gulf of Alaska (55° N, 155° W), Ocean Station "P" (average values at 50° N, 150° W and 50° N, 140° W), west of California Current (35° N, 135° W), adjacent to the Kuroshio Current (30° N, 160° E), the Oyashio Current (45° N, 155° E), and the Kamchatka Current (50° N, 160° E).

At each grid point the mean values and the standard deviations of the transport components from values for the same month from previous years are given in tabular form. In addition, the mean values of the integrated total and geostrophic transport for the month and eleven preceding months are given and compared with similar averages in previous years to indicate the long term trend of computed transport.

The departures of the monthly values from their means have been divided into three classes in terms of the number of standard deviations from the mean. The classes are:

Class 1: departure of less than one standard deviation from the mean (68% of values for a Gaussian distribution). Values falling in this range are termed "normal".

Class 2: departures of one to two standard deviations from the mean (17% of values for a Gaussian distribution). These values will be referred to as "above normal" or "below normal".

*To file in my book  
have a number  
...*

Class 3: departures greater than two standard deviations from the mean (5% of values for a Gaussian distribution). Values whose variation falls in this range will be denoted as "strongly above normal" or "strongly below normal".

### Transport charts

- I. Monthly mean sea-level atmospheric pressure given as the anomaly of mean atmospheric pressure from 1000 mbs. in units of 1/10 millibars.
- II. Meridional component of Ekman transport ( $V_E$ ) in units of 10 metric tons/km/sec.
- III. Zonal component of Ekman transport ( $U_E$ ) in units of 10 metric tons/km/sec.
- IV. Meridional component of total transport ( $V$ ) in units of 100 metric tons/km/sec.

The values shown on chart IV are  $-V$

- V. Integrated total transport ( $\Psi$ ) in units of 100,000 metric tons/sec.
- VI. Integrated geostrophic transport ( $\Psi_g$ ) in units of 100,000 metric tons/sec.

The convention of signs adopted is that northward and eastward transport shall be considered as positive and southward and westward flow shall be negative.

### References

- Fofonoff, N.P. MS, 1960. Transport computations for the North Pacific Ocean 1955-58. Fish. Res. Bd. Canada, MS Rept., Oceanogr. and Limnol. Series, Nos. 77-80, 93 pp.
- MS, 1961. Transport computations for the North Pacific Ocean 1959. Fish. Res. Bd. Canada, MS Rept., Oceanogr. and Limnol. Series, No. 85, 181 pp.
- Fofonoff, N.P., and C. Froese. MS, 1960. Programs for oceanographic computations and data processing on the electronic digital computer ALWAC III-E. M-1 miscellaneous programs. Fish. Res. Bd. Canada, MS Rept., Oceanogr. and Limnol. Series, No. 72, 35 pp.
- Munk, W.H. 1950. On the wind-driven ocean circulation. J. Meteorol. 1 (2), 79-93.
- Stommel, H. 1948. The westward intensification of wind-driven ocean currents. Trans. Amer. Geophys. Union 29, (2): 202-206.
- Sverdrup, H.V. 1947. Wind-driven currents in a baroclinic ocean; with applications to the equatorial currents of the Eastern Pacific. Proc. Nat. Acad. Sc., 33 (11): 318-326.

Assessment of transport calculations for November, 1961

The atmospheric pressure field was relatively normal for the month of November. The northern low pressure area was shifted slightly to the north over the Bering Sea and was of lesser intensity than usual. The high pressure areas over China and off the coast of the United States were present as in previous Novembers.

The components of Ekman transport were normal except the meridional component for the Gulf of Alaska and the zonal components for Ocean Station "P" and the California Current which were "below normal".

The total transport components were slightly "below normal" for the Gulf of Alaska and the California Current, "above normal" for the Kuroshio and "normal" for the remaining three grid points.

The components of integrated total and geostrophic transport were normal for all selected grid points save the Oyashio and Kuroshio Currents which were "below normal".

The only grid point to show deviation from the "normal" trends of integrated transports was the California Current which was only slightly "below normal".

C.K. Ross

Table I. A comparison of transport components at selected grid points with the average values for the same month from previous years.

1. Kamchatka Current (55° N, 160° E)						4. Gulf of Alaska (55° N, 155° W)							
	Nov 1961	Nov 1960	Nov Mean (55-60)	$\sigma$	$\frac{ x-\bar{x} }{\sigma}$	Class		Nov 1961	Nov 1960	Nov Mean (55-60)	$\sigma$	$\frac{ x-\bar{x} }{\sigma}$	Class
$V_E$	-40	-10	-48.8	40.4	0.22	1	$V_E$	-20	-7	0.2	14.3	1.41	2
$U_E$	-5	-5	-6.7	10.9	0.16	1	$U_E$	8	-5	10.5	22.6	0.11	1
$-V$	-22	18	-38.7	40.6	0.41	1	$-V$	-155	-75	-87.8	53.7	1.25	2
$\Psi$	281	323	326.0	176	0.26	1	$\Psi$	133	121	167.2	50.3	0.68	1
$\Psi_0$	318	347	350.0	173	0.19	1	$\Psi_0$	133	120	167.2	50.5	0.68	1
$\Psi_9$	203.2	313.3	230.0	61.0	0.44	1	$\Psi_9$	100.0	101.0	114.4	36.0	0.40	1
$\Psi_9$	217.4	329.2	243.0	64.1	0.40	1	$\Psi_9$	99.8	101.5	114.0	35.5	0.40	1
2. Oyashio Current (45° N, 155° E)						5. Ocean Station "P" (50° N, 145° W)							
$V_E$	-27	-3	-40.2	27.0	0.49	1	$V_E$	-62.0	-69	-51.5	26.1	0.40	1
$U_E$	-3	-4	-4.2	7.9	0.15	1	$U_E$	15.5	25	64.8	44.3	1.11	2
$-V$	41	2	51.7	45.3	0.24	1	$-V$	-33.5	-125	-65.2	46.8	0.68	1
$\Psi$	-387	101	5.7	217	1.82	2	$\Psi$	73.0	118	40.8	67.8	0.48	1
$\Psi_0$	-352	146	49.3	214	1.85	2	$\Psi_0$	77.0	123	45.2	66.4	0.48	1
$\Psi_9$	44.6	26.5	66.3	59.7	0.36	1	$\Psi_9$	42.3	51.8	35.8	17.6	0.37	1
$\Psi_9$	76.7	61.7	108.6	55.2	0.58	1	$\Psi_9$	48.9	53.1	38.6	18.1	0.57	1
3. Kuroshio Current (30° N, 140° E)						6. California Current (35° N, 135° W)							
$V_E$	26	7	35.7	17.5	0.55	1	$V_E$	-17	-38	-10.5	15.3	0.42	1
$U_E$	-29	-9	-26.8	15.9	0.14	1	$U_E$	-5	-5	0.5	3.1	1.45	2
$-V$	30	2	-6.7	27.1	1.35	2	$-V$	54	44	8.7	40.6	1.11	2
$\Psi$	-193	-185	173.0	17.5	1.14	2	$\Psi$	-18	-19	-19.0	12.2	0.82	1
$\Psi_0$	-203	-190	183.7	16.7	1.24	2	$\Psi_0$	-17	-17	-18.8	11.6	0.16	1
$\Psi_9$	-328.6	-247.0	-290.8	52.2	0.72	1	$\Psi_9$	-38.3	26.6	-32.2	5.0	1.22	2
$\Psi_9$	-330.4	256.3	-294.6	48.9	0.73	1	$\Psi_9$	-36.3	-26.4	-30.2	5.1	1.19	2

Explanation of table:

$\sigma$  is based on (55-60) values.

$\frac{|x-\bar{x}|}{\sigma}$  denotes deviation from mean in terms of standard deviation.

$\Psi, \Psi_9$  are trends of integrated transports based on the straight mean of the month and the eleven preceding months.

Classes are explained on pages 1-2.

Nov 1 Nov 30 1961

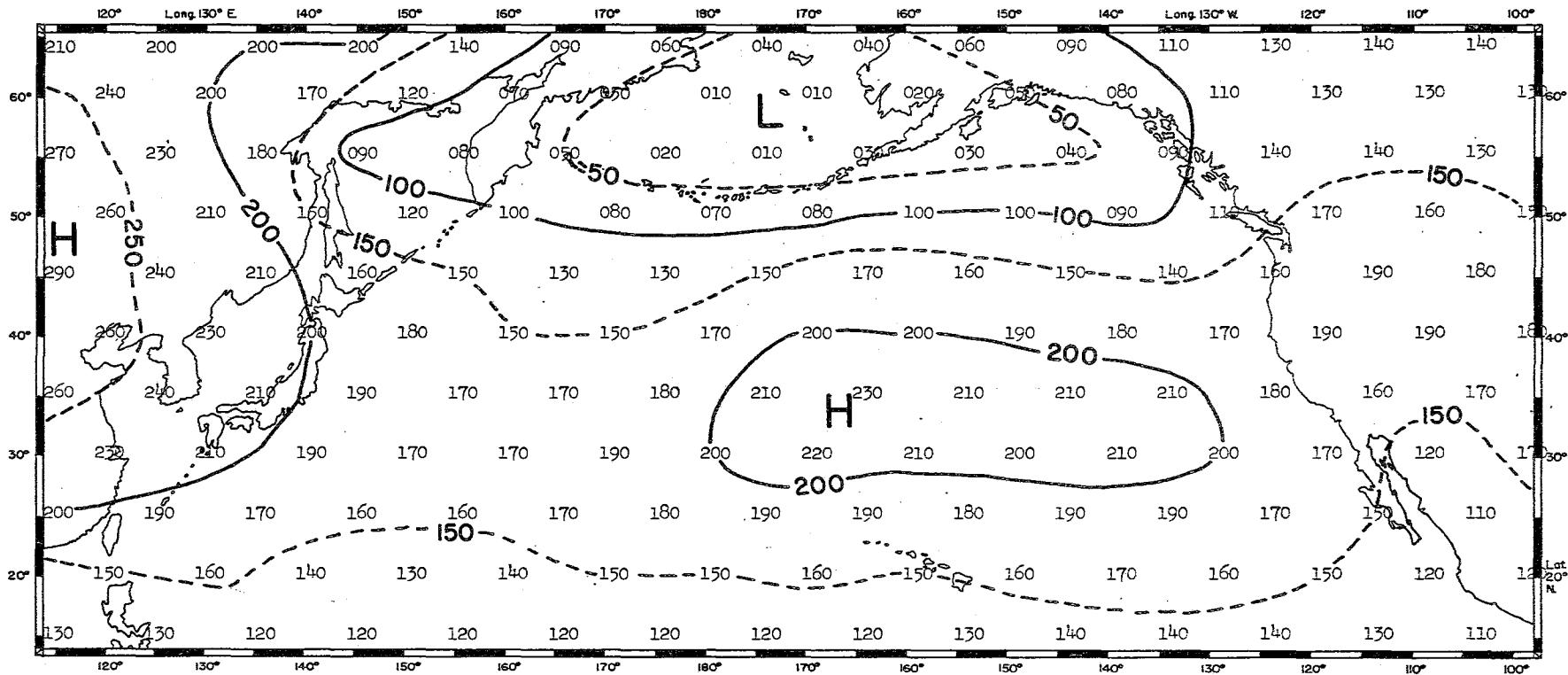

I. Atmospheric Pressure

Nov 1 - Nov 30 1961

Nov 1 Nov 30 1961

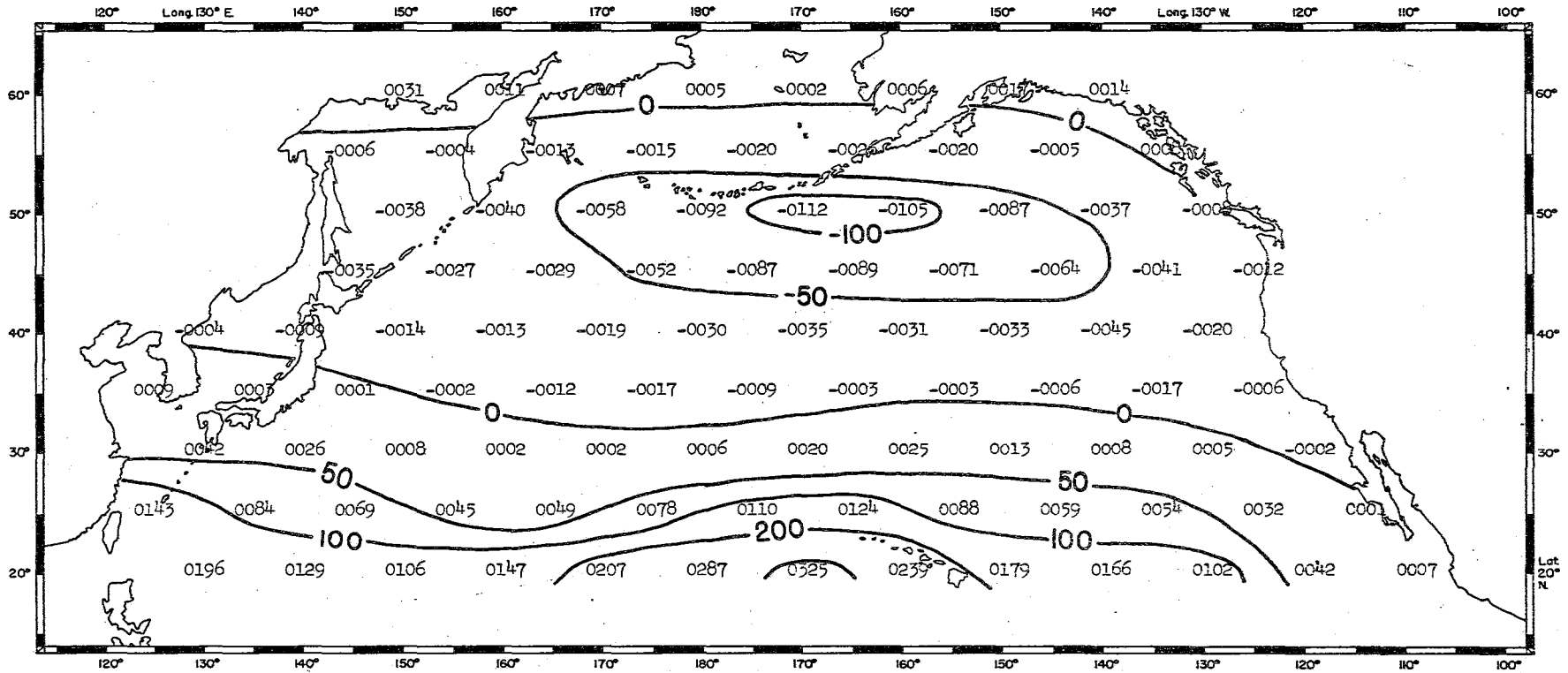

II. Meridional Component of Ekman Transport

Nov 1 - Nov 30 1961

Nov 1 Nov 30 1961

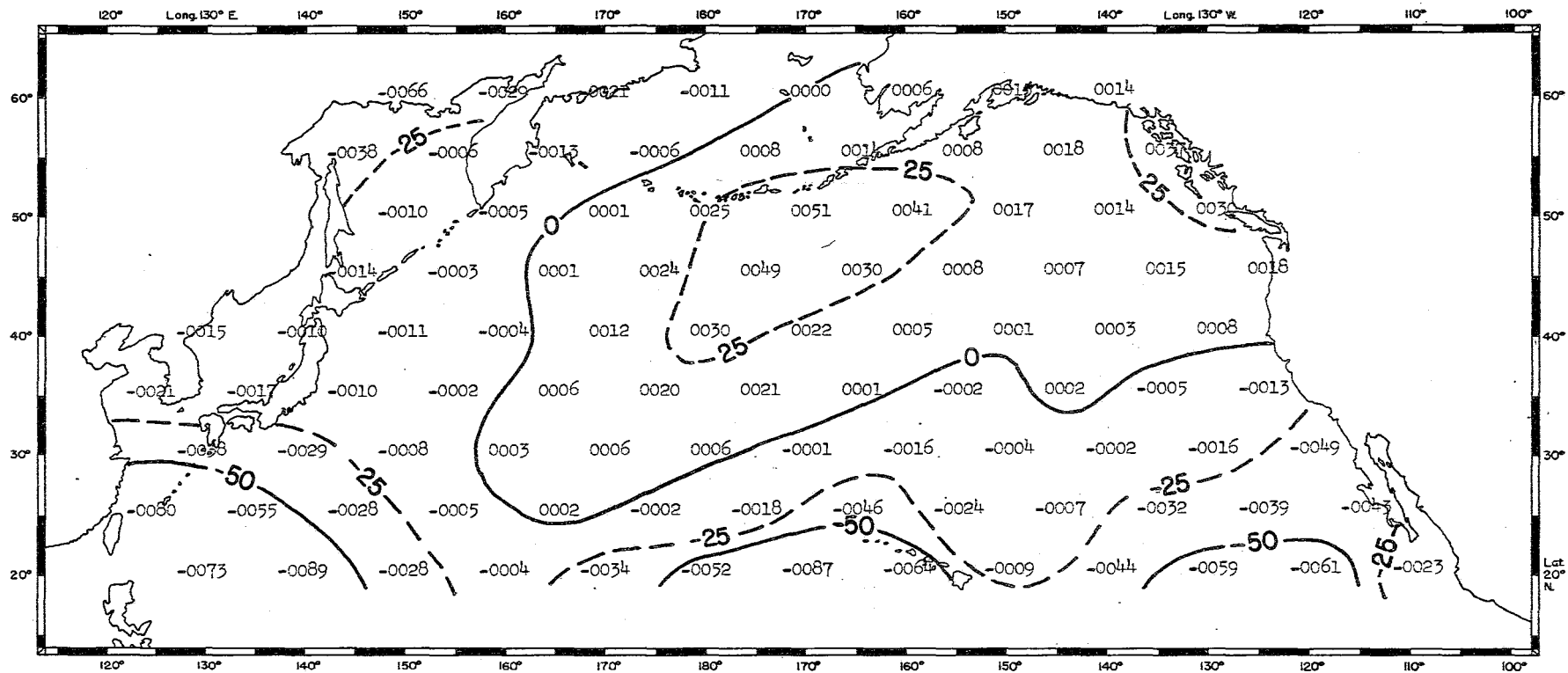

III. Zonal Component of Ekman Transport

Nov 1 -- Nov 30 1961

Nov 1 - Nov 30 1961

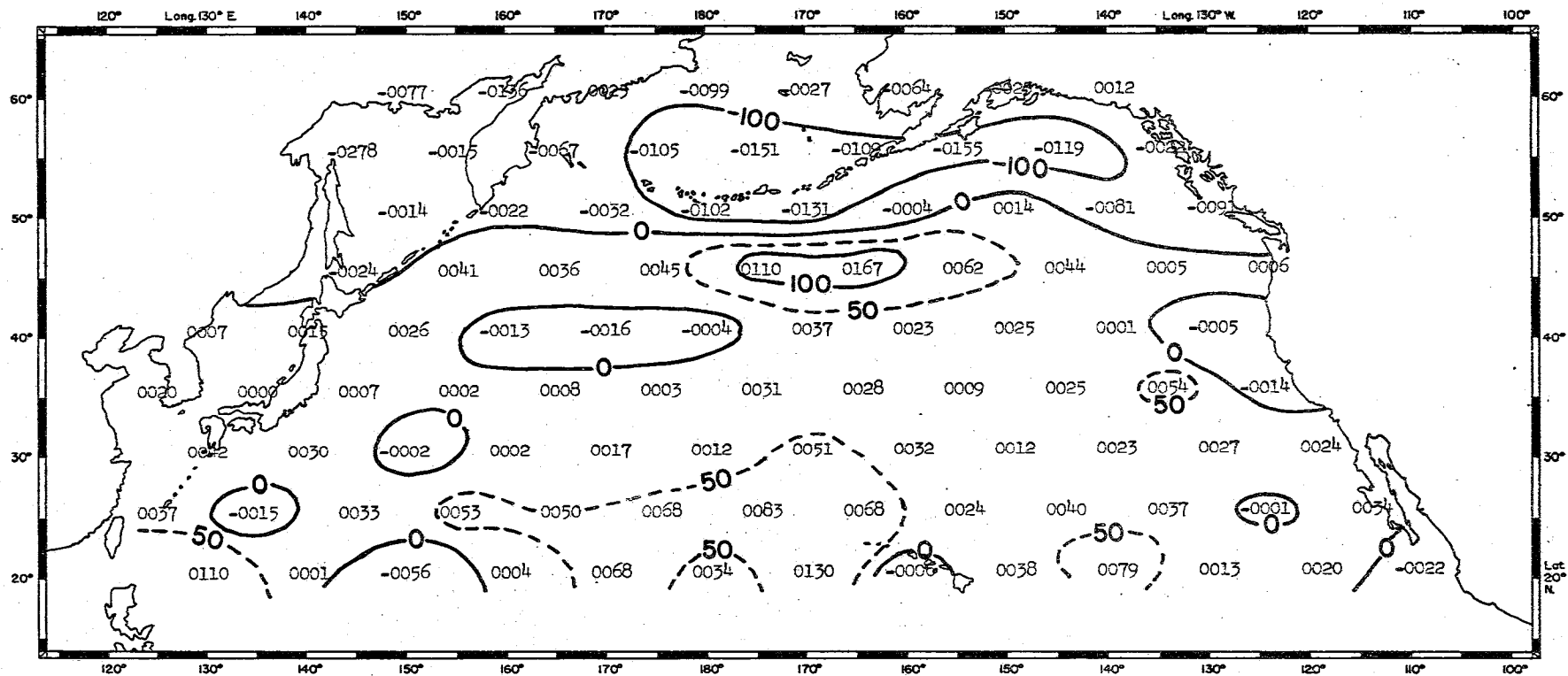

IV. Meridional Component of Total Transport

Nov 1 - Nov 30 1961

Nov 1 Nov 30 1961

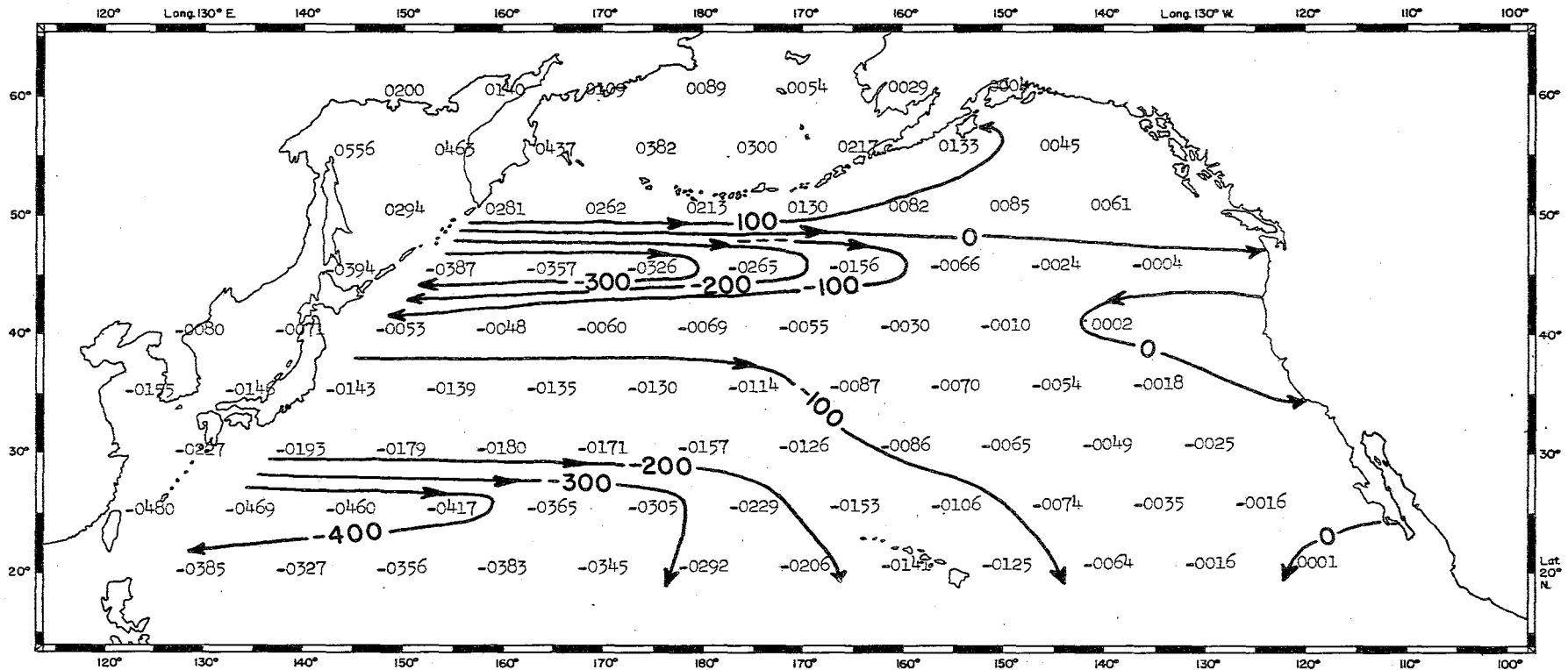

V. Integrated Total Transport

Nov 1 - Nov 30 1961

Nov 1 - Nov 30 1961

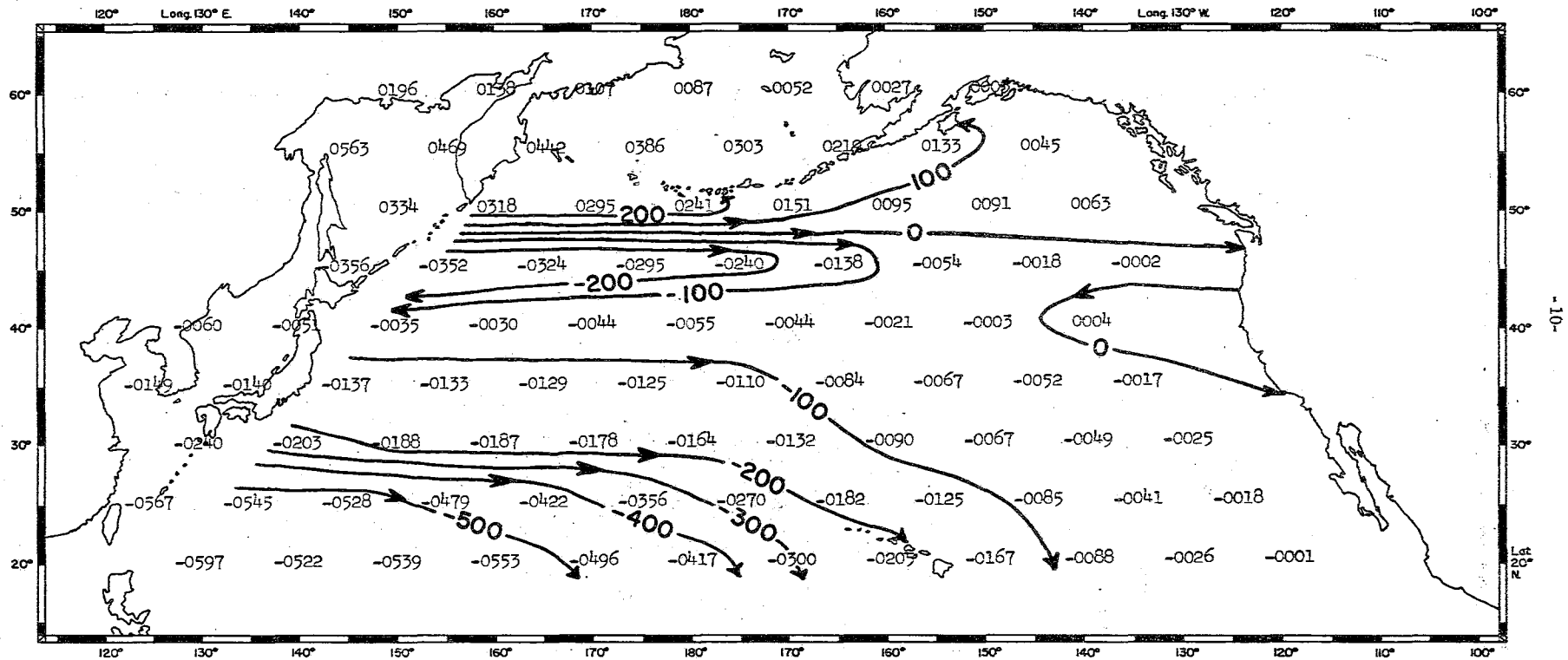

VI. Integrated Geostrophic Transport

Nov 1 - Nov 30 1961

MERIDIONAL COMPONENT OF EKMAN TRANSPORT  
in 10 metric tons/second/kilometer

FIG. 1

---- 1960

I (1955-60) mean  $\pm \sigma$

--- 1961

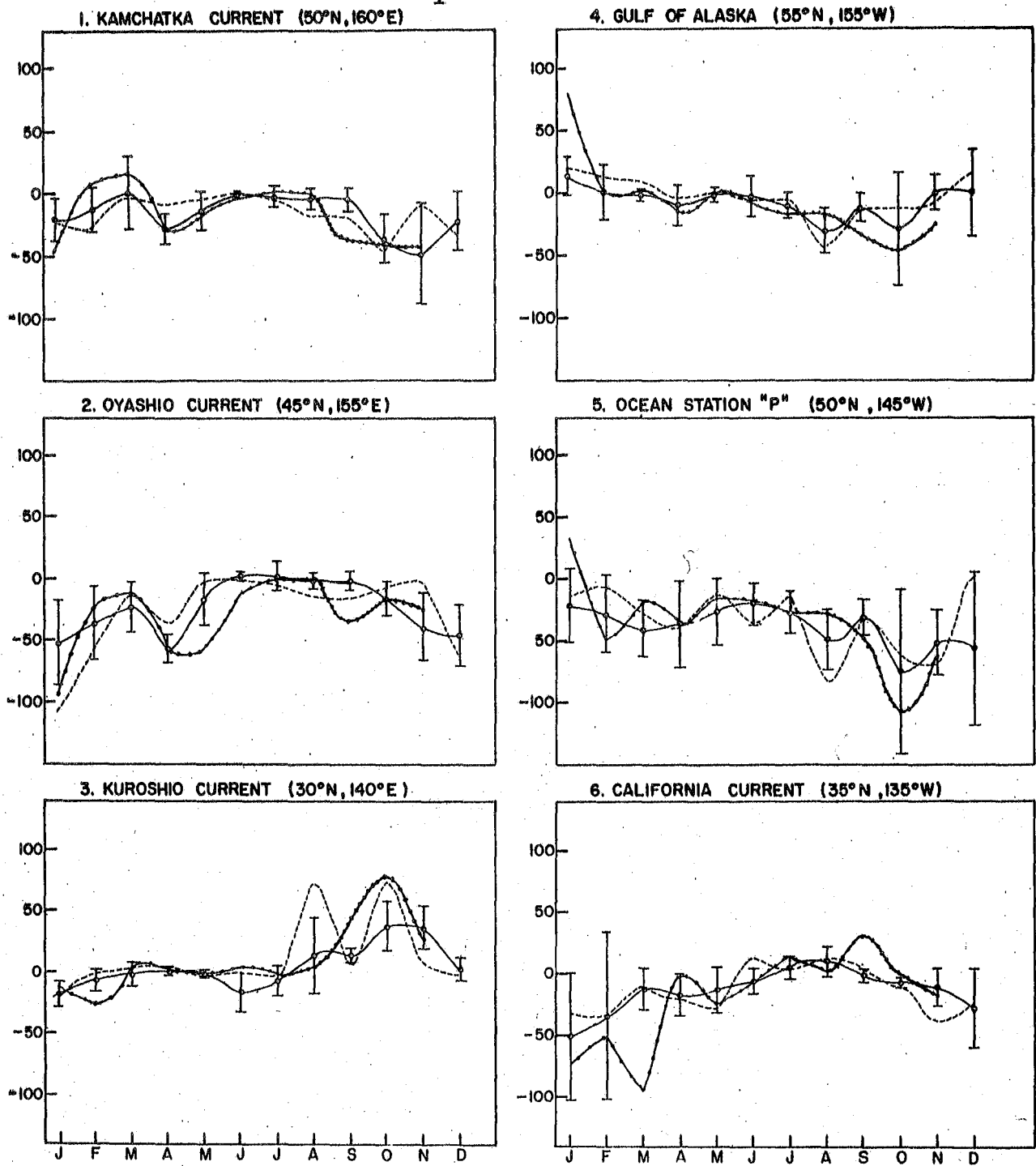

**FIG 2** ZONAL COMPONENT OF EKMAN TRANSPORT  
in 10 metric tons / second / kilometer

--- 1960

⊥ (1955-60) mean ± σ

--- 1961

**1. KAMCHATKA CURRENT (50°N, 160°E)**

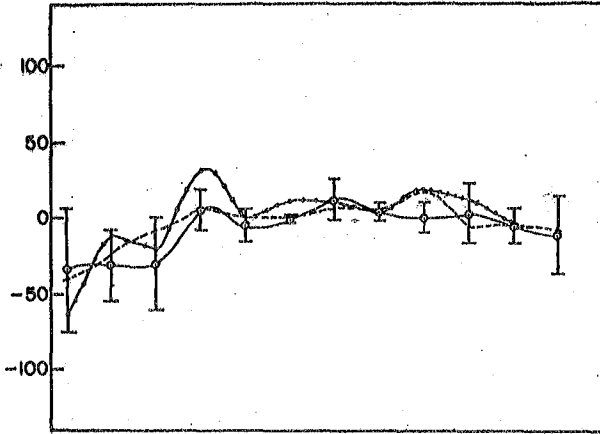

**4. GULF OF ALASKA (55°N, 155°W)**

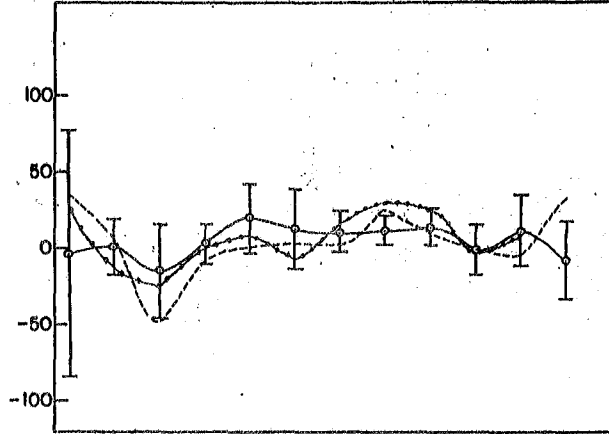

**2. OYASHIO CURRENT (45°N, 155°E)**

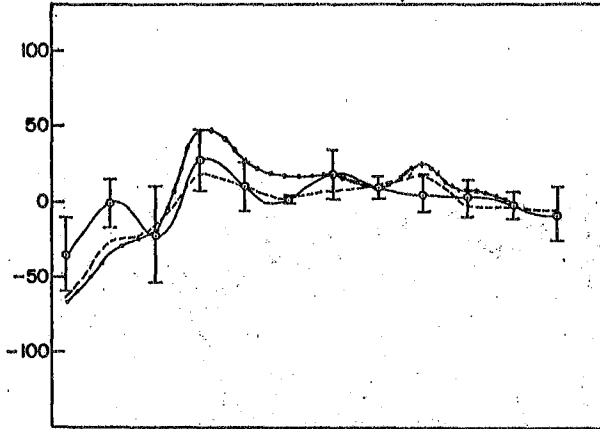

**5. OCEAN STATION "P" (50°N, 145°W)**

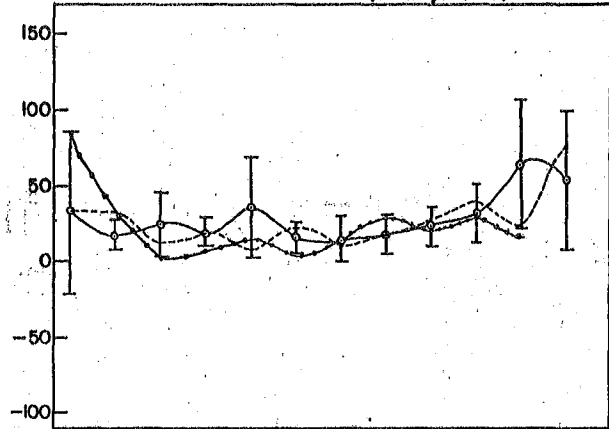

**3. KUROSHIO CURRENT (30°N, 140°E)**

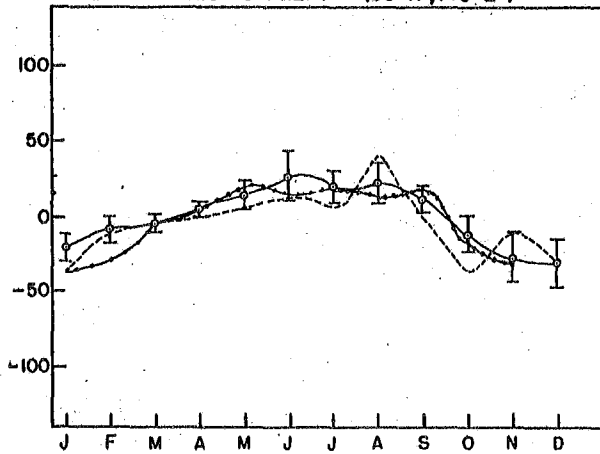

**6. CALIFORNIA CURRENT (35°N, 135°W)**

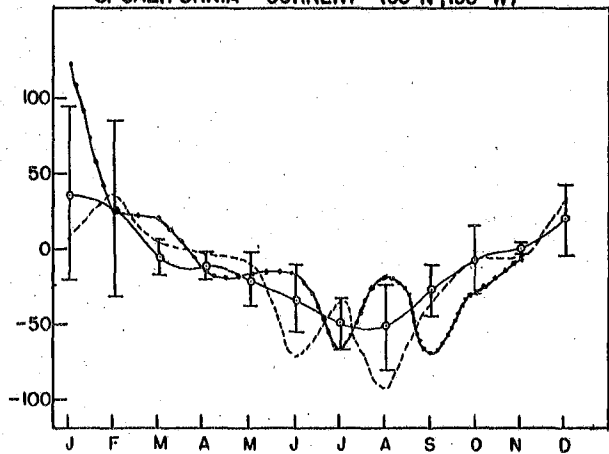

**FIG. 3** MERIDIONAL COMPONENT OF TOTAL TRANSPORT  
100 metric tons/second/kilometre

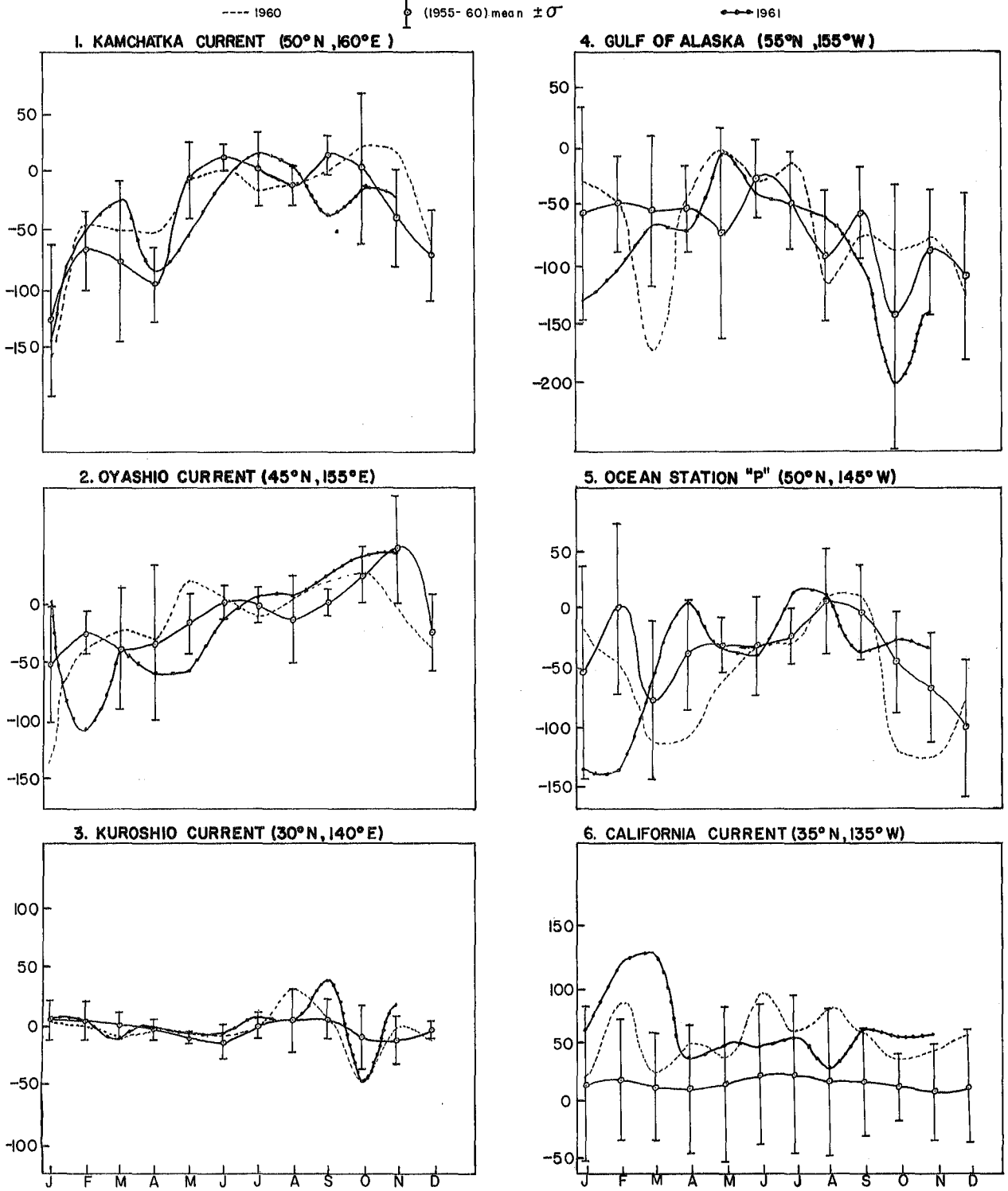

**FIG. 4** INTEGRATED TOTAL TRANSPORT  
in millions of metric tons /second.

----- 1960

⊥ (1955-60) mean ± σ

----- 1961

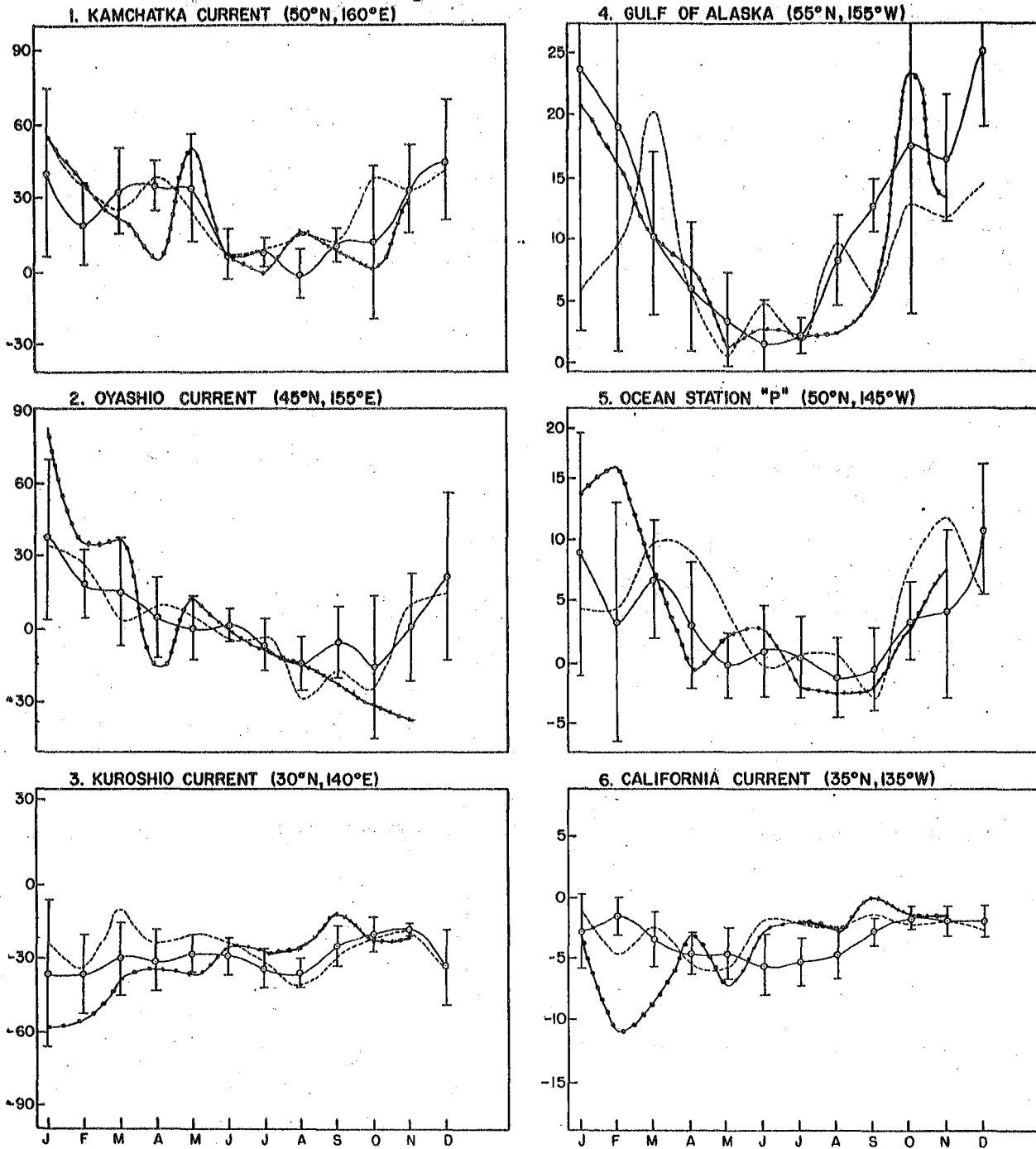

FIG. 5 INTEGRATED GEOSTROPHIC TRANSPORT  
in millions of metric tons/second

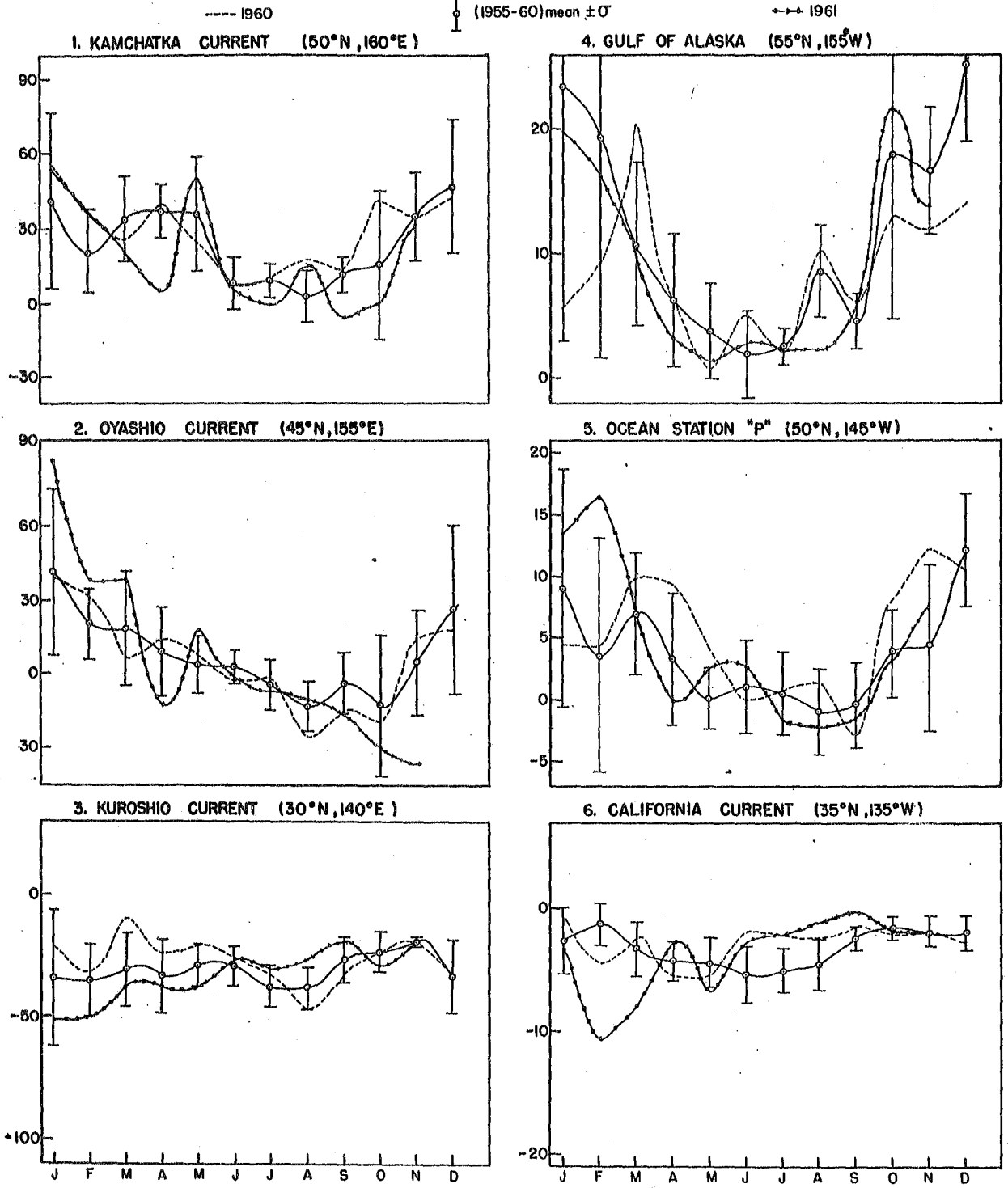
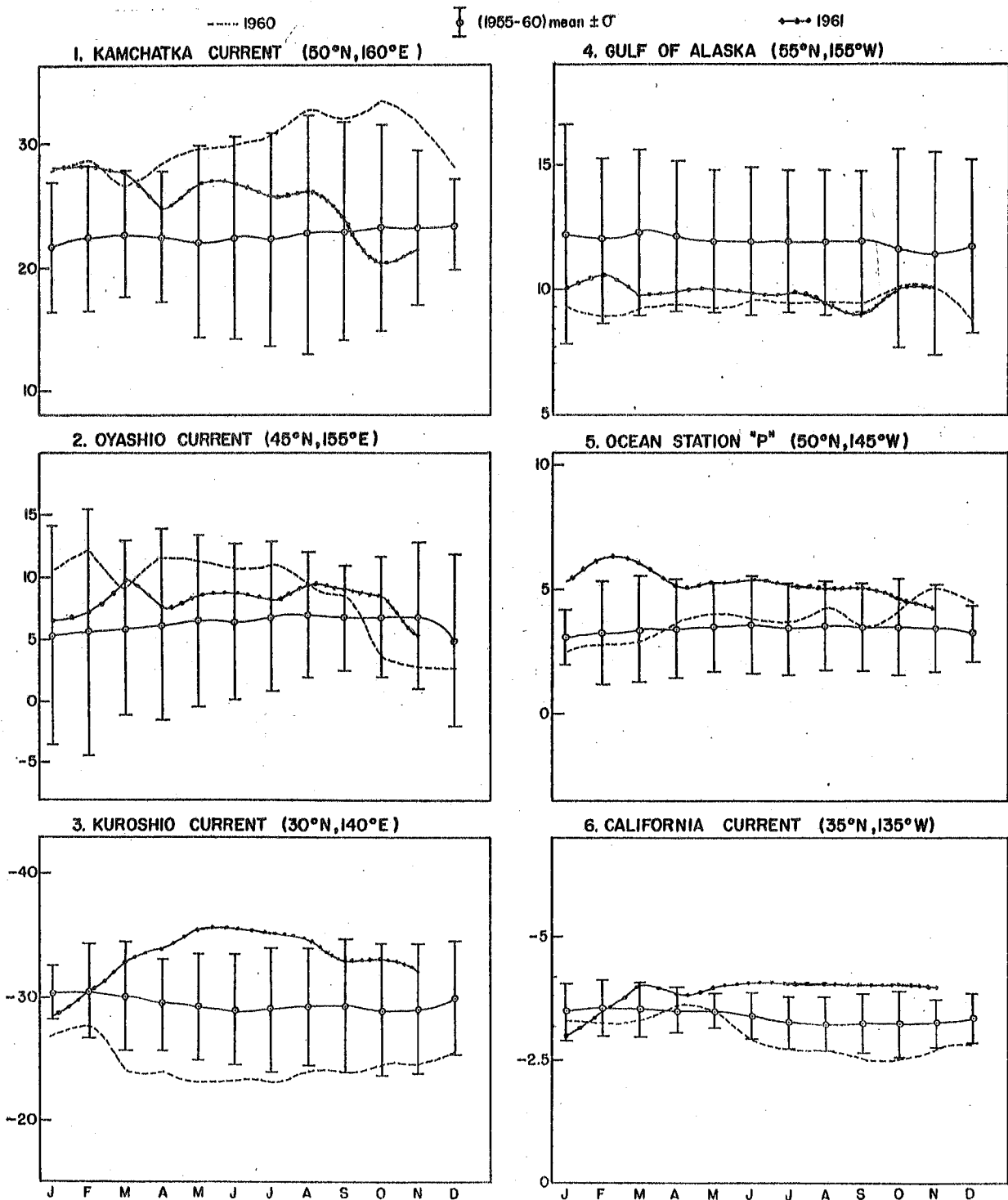
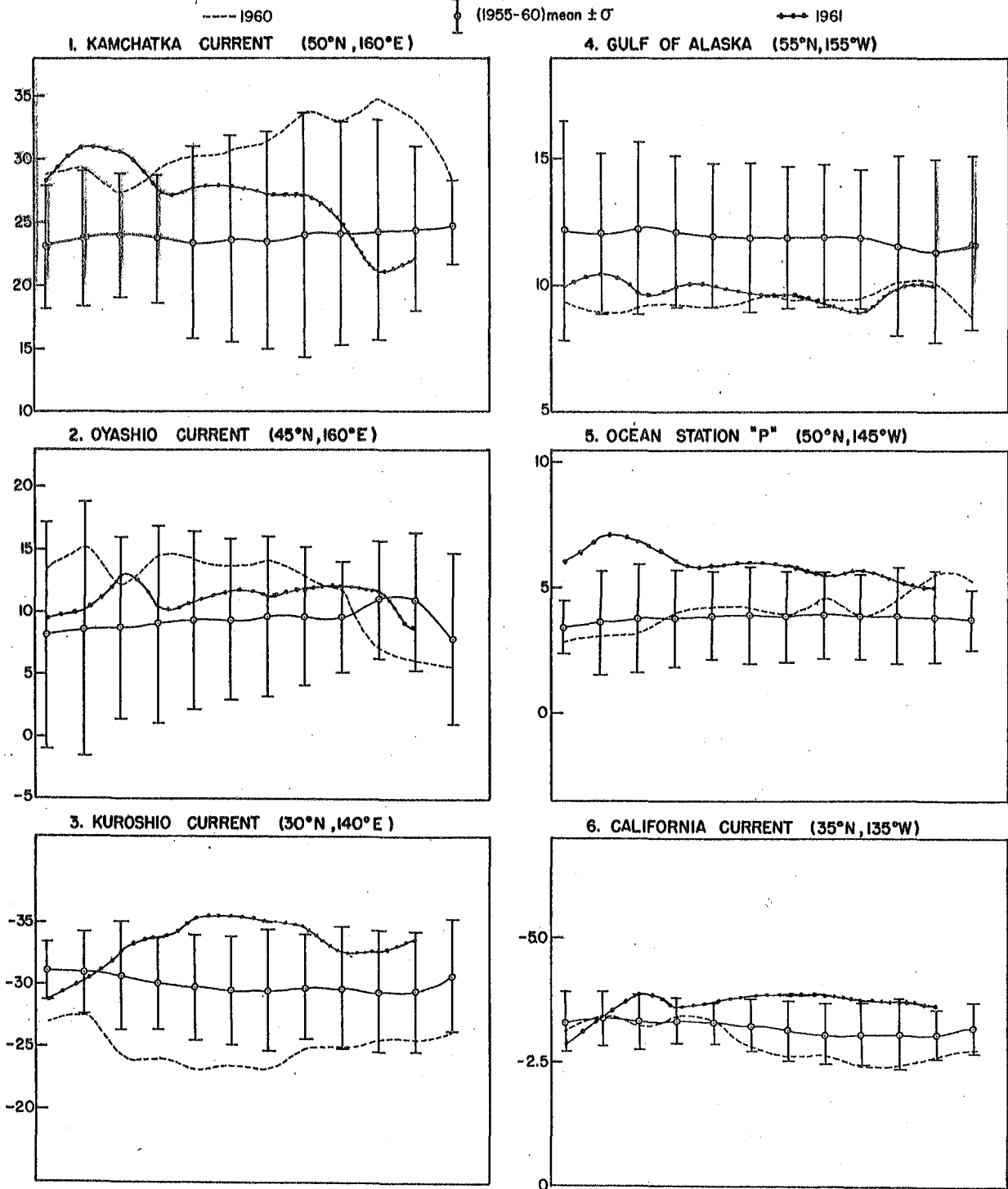

FIG. 6 TREND OF INTEGRATED TOTAL TRANSPORT  
in millions of metric tons/second



**FIG. 7** TREND OF INTEGRATED GEOSTROPHIC TRANSPORT  
in millions of metric tons /second



Dr. Needer

FISHERIES RESEARCH BOARD OF CANADA  
Pacific Oceanographic Group  
Nanaimo, B. C.

Circular 1962 - 5  
February 9, 1962.

Oceanographic observations from Weathership C.M.S. "St.  
Catharines". Cruise P-61-4, September 13-October 30, 1961

Observations between "Swiftsure" and Station "P"

The station positions occupied between "Swiftsure" and Station "P" are shown in Fig. 1.

Temperature observations

Figure 2 shows a section of temperature between "Swiftsure" and Station "P" for mid-September. It can be seen that the surface temperature was 15° C at Station 1, rose to a maximum (16.3° C) at Station 3 and then fell gradually to a minimum (13.5° C) at Station "P". During the six week interval between mid-September and the end of October cooling of the surface water occurred in the section, being most marked at Station 1 (by 5 C°) and least at Station "P" (by 3 C°). As shown in Fig. 3, the surface temperature for the end of October was 9.9 °C at Station 1. From there it rose to a maximum (12.2 °C) at Station 3, where a maximum was previously noted (Fig. 2). Then it decreased gradually to a minimum (9.9° C) at Station 6A (midway between Station 6 and Station "P"), and increased to 10.4° C at Station "P".

At mid-September and also the end of October the seasonal thermocline increased in magnitude and depth seaward from "Swiftsure".

There was a greater temperature decrease in the upper 50 m of water during the period from the middle of September to the end of October, 1961 (3 C°) than during the corresponding period in 1959 (1 C°) (Circular 1959-27). The temperature inversions appearing between 100 and 200 m depth almost disappeared in 1961 whereas they persisted in 1959 (data not available for 1960).

Figure 4 shows the temperature changes in the depth interval 100 through 500 m between "Swiftsure" and Station "P". General cooling occurred during the period from the beginning of August to mid-September with marked cooling towards the coast and west of mid-section; however, warming occurred east of the middle and east of Station "P".

In contrast to this there was less change during the following six weeks to the end of October except near the coast where marked cooling occurred at Station 1 and warming at Station 2.

From Station 3 to Station 6A between the middle of September and the end of October warming was general from 100 to 150 m depth and cooling was general from 150 to 200 m depth. This warming and cooling is accompanied by

the disappearance of the temperature inversions. The temperature changes during the period from the beginning of August to the middle of September are not as easily related to the formation of the temperature inversions during that period.

### Salinity observations

As shown in Fig. 5, the surface salinity in mid-September between "Swiftsure" and Station "P" varied from minimums at Stations 2, 4 and 5 to maximums at Station 3, 4A and "P". The surface salinity at the end of October (Fig. 6) became more regular and increased from the coast to Station "P".

During both periods, wave-like features were evident below 200 m depth in the salinity section as shown in Fig. 5 and 6. It is of interest to note that while a "hump" occurred at Station 4 (isohalines 33.9 and 34.0‰) in September, a "dip" occurred in October.

On comparing the isohalines occurring between 100 and 500 m at Station 2 for the two periods it is seen that the salinity increased from the middle of September to the end of October. Since the temperature also increased here at the same time it is probable that there was a northward transport (assuming warmer more saline water lies to the south).

### Observations at Station "P"

Temperature observations: - As shown in Fig. 7 the monthly mean surface temperature for August and September are appreciably warmer (1-2°) than the corresponding means of 1960. The October mean is nearly the same as the 1960 mean while the November mean is again about 1° warmer than the 1960 mean.

The August, September and October means are about 1° warmer than the 10-year monthly means (1951-1960) and the November value is about 1° lower than the 10-year mean.

Temperature structures for selected times from July 4 to October 11, 1961 are shown in Fig. 8. This series of structures shows a sequence of the growth and decay of the thermocline during this period.

Temperature inversions occurred in the depths between 100 and 200 m (Fig. 8). However, they were evident in only half the total number of observations.

As shown in Fig. 9 temperature inversions between 100 and 200 m are evident every year at the beginning of November for the years from 1958 through 1961.

Change of heat content: - The average rate of change of heat content from the surface to 100 m depth during the period July 4-August 3 was +320 gm cal/cm<sup>2</sup>/day. During the period August 3-September 17 it was +370 gm cal/cm<sup>2</sup>/day and during the period September 17-October 11 it was -167 gm cal/cm<sup>2</sup>/day. These values are somewhat larger than expected during these periods.

Oxygen observations: - The oxygen structure at Station "P" for selected times between July 4 and October 11, 1961 are shown in Fig. 11. In general, the oxygen concentration varied inversely as the temperature above the thermocline, indicating its dependence on the solubility of oxygen in water.

From 100 to 200 m it can be seen that the oxygen concentration increased when the salinity decreased (Fig. 10 and 11). This could indicate a northward transport of water.

Figure 12 shows oxygen structures for the end of October for the years 1959 - 1961. The oxygen concentration was 0.025 - 0.05 mg at/l less in 1961 than in the previous two years.

Current observations: - One parachute drogue drift measurement was attempted on October 6, 1961. Two drogues were set out, one at 10 m depth, the other at 60 m depth. The drogues were positioned once four hours after they were released. They had drifted 2 1/4 and 2 1/2 miles north west respectively. The 60 m drogue travelled 1/4 of a mile further than the 10 m drogue.

Biological observations: - There were two Pomfret and one small shark caught between September 16 and 30. Very little fishing was done after that.

Black footed albatross were numerous throughout the patrol though there were fewer at the end of October than in the middle of September. Up to six Laysan albatross were observed towards the end of October.

Numerous clumps of kelp were observed throughout the patrol.

D.G. Robertson.

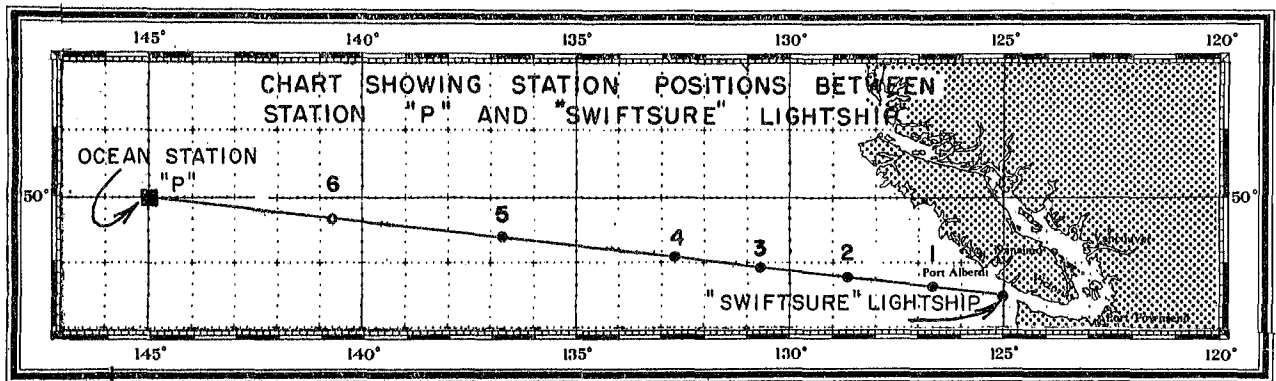

Figure 1.

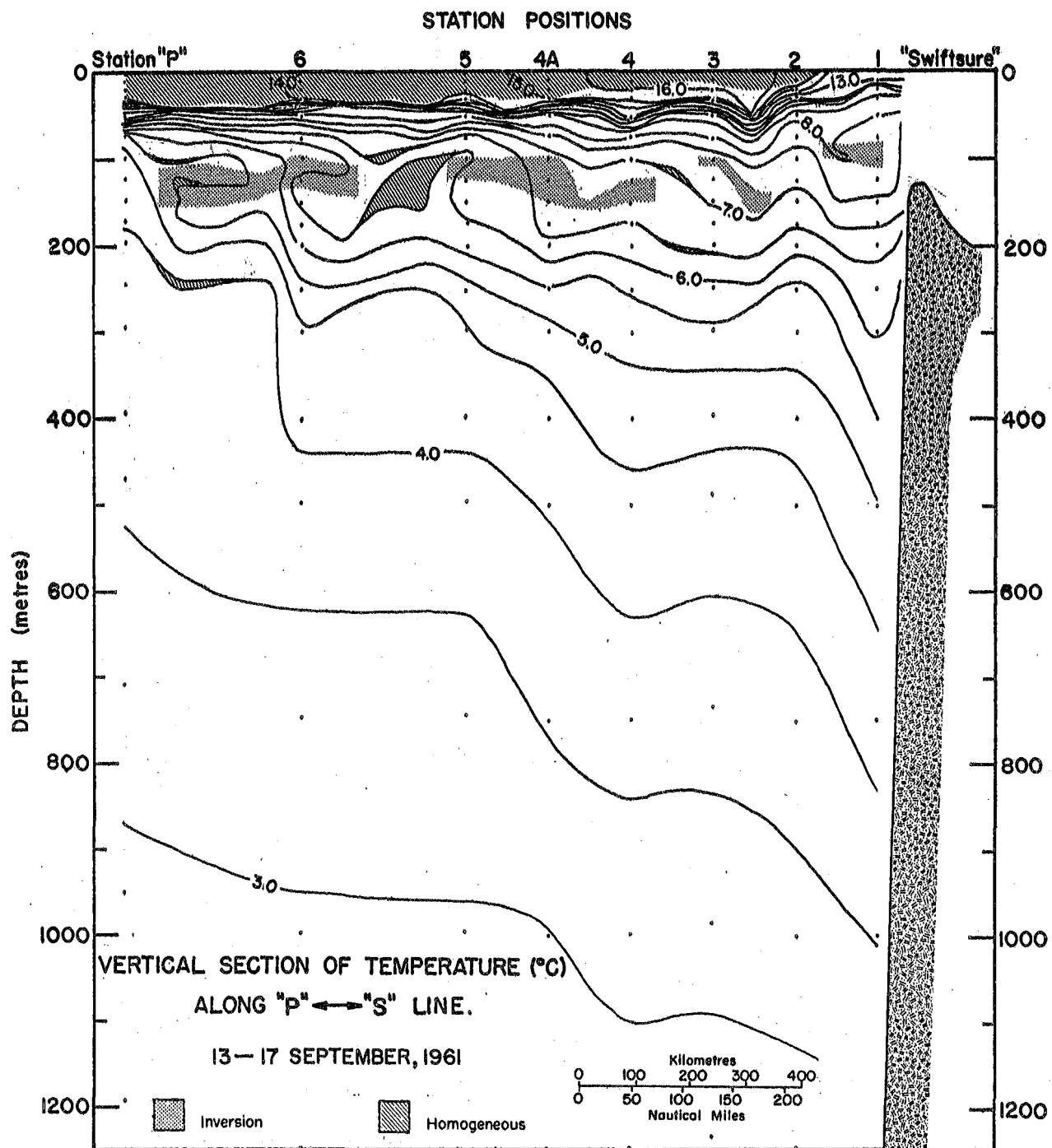

FIGURE 2.

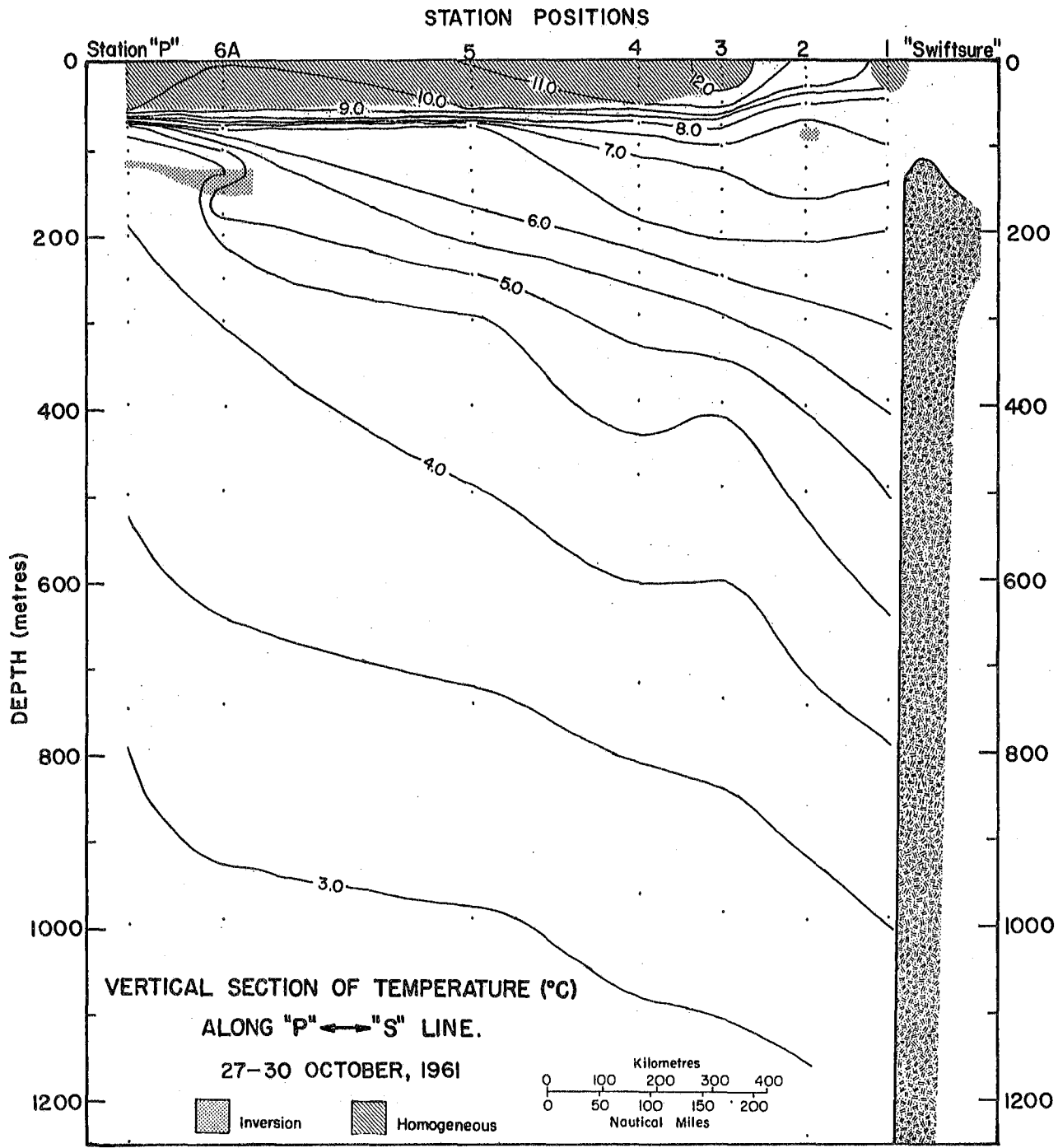

FIGURE 3.

STATION POSITIONS

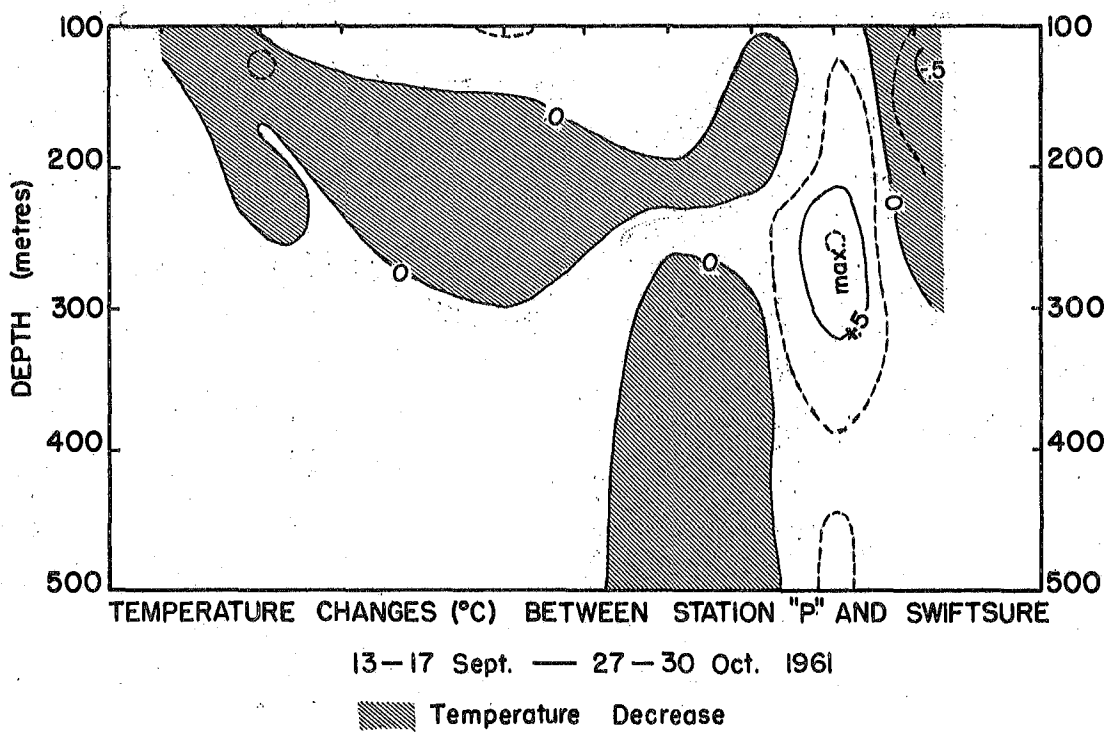
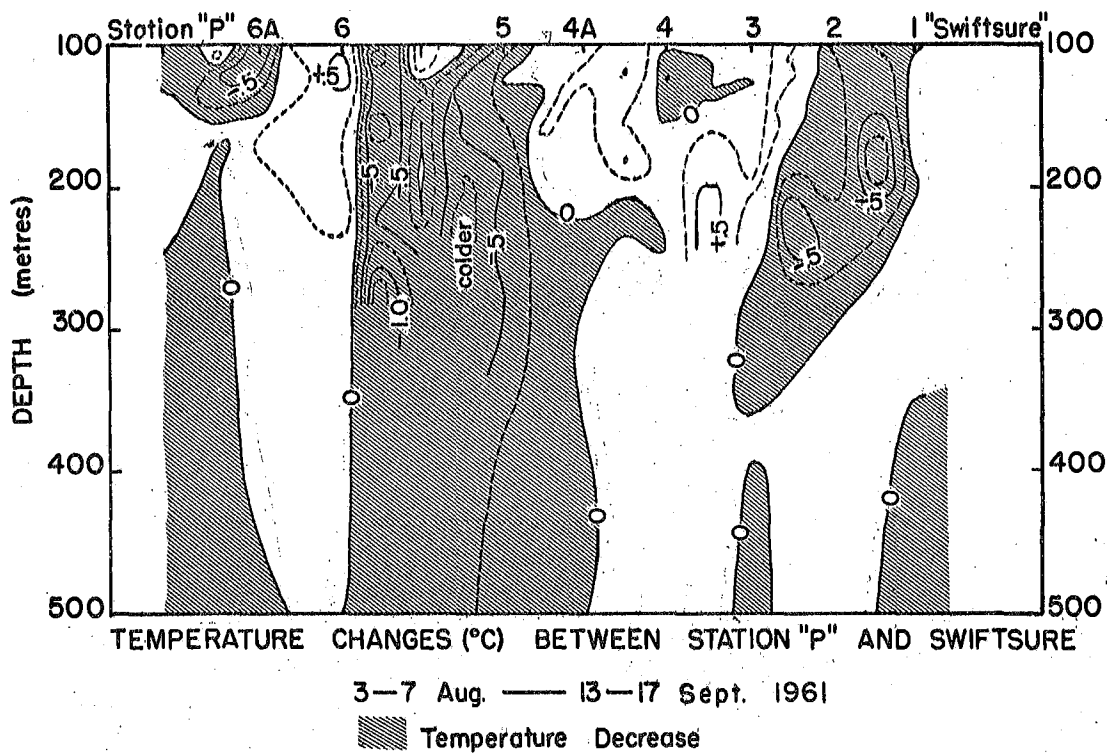

FIGURE 4.

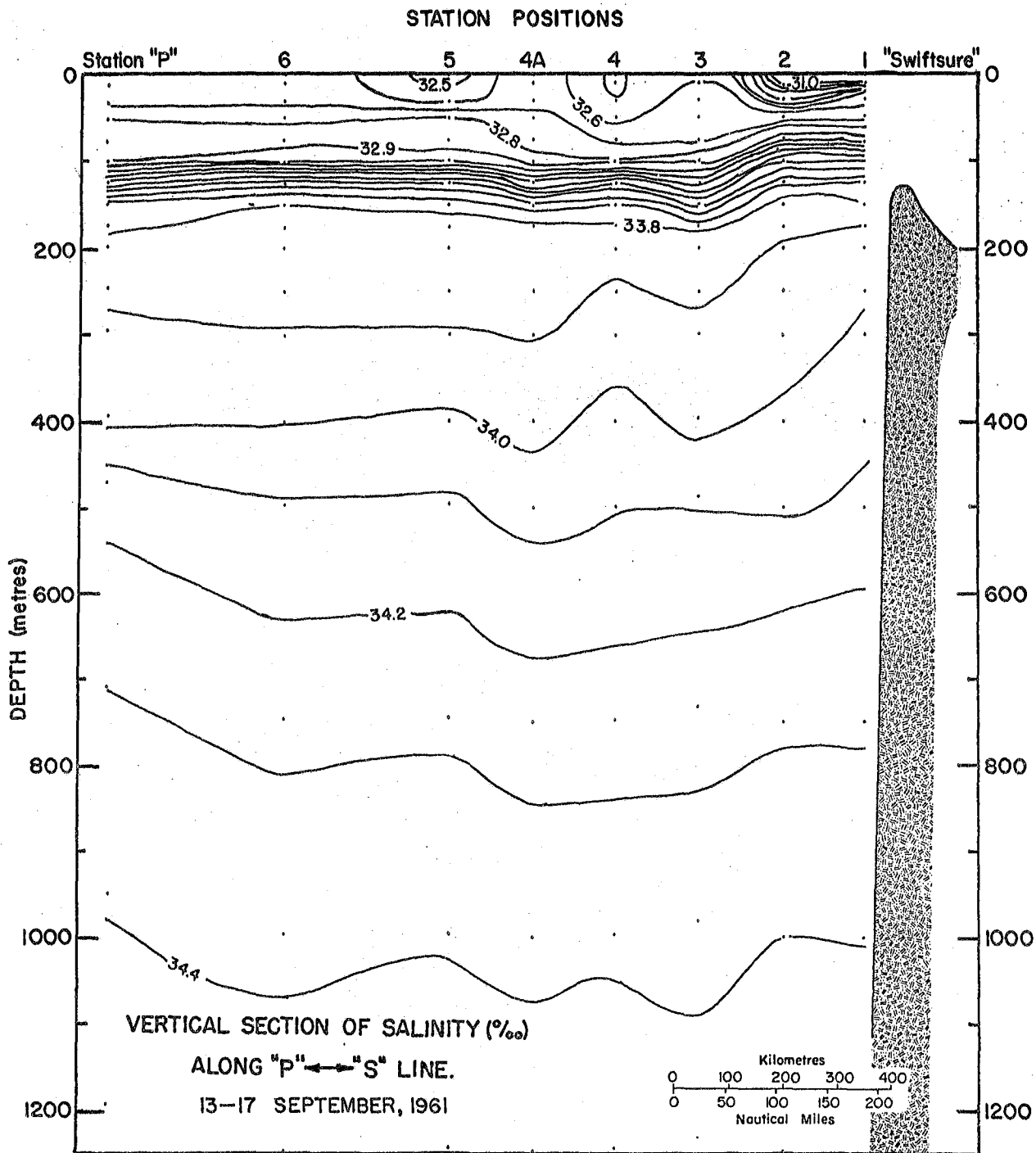

FIGURE 5.

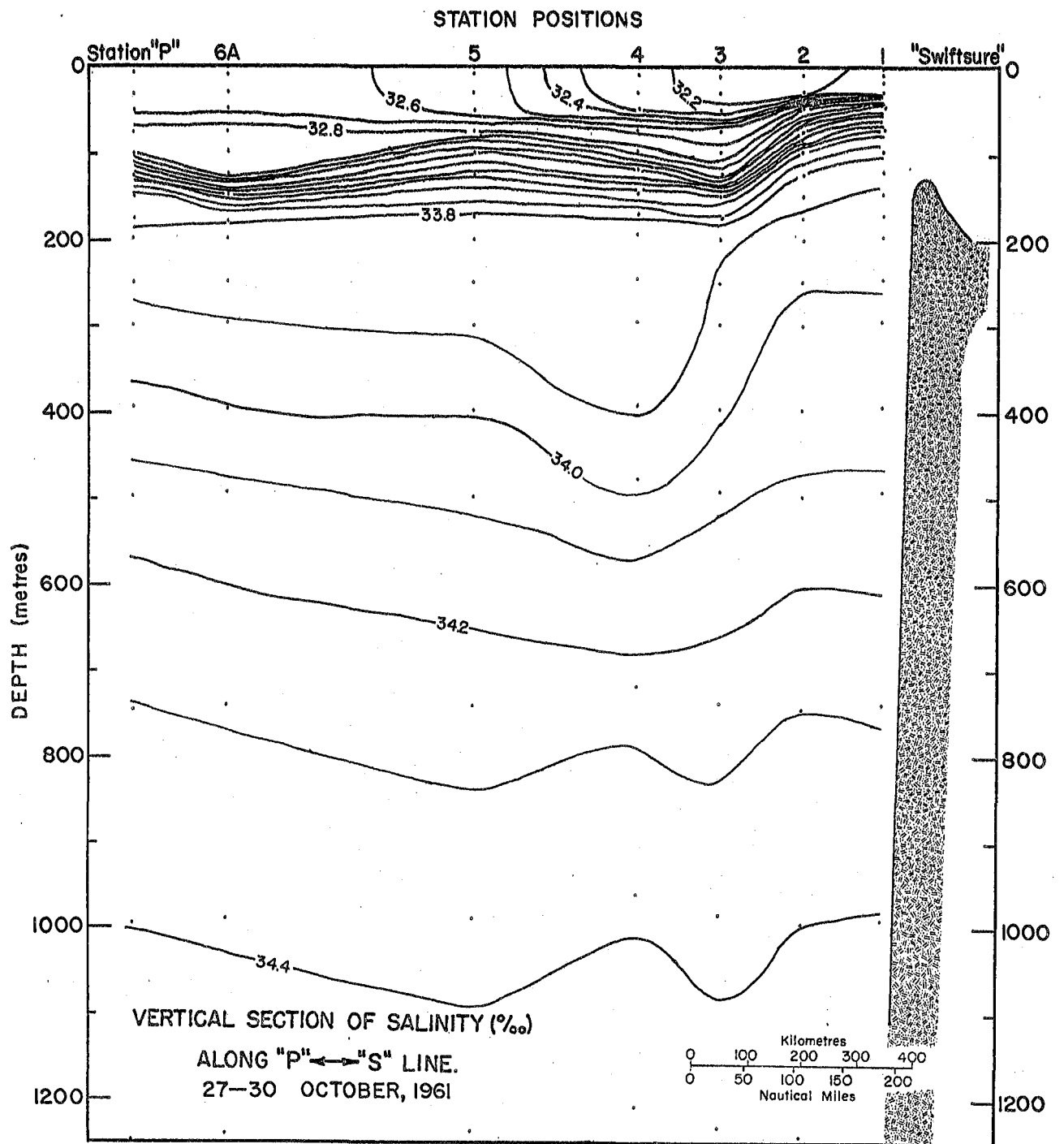

FIGURE 6.

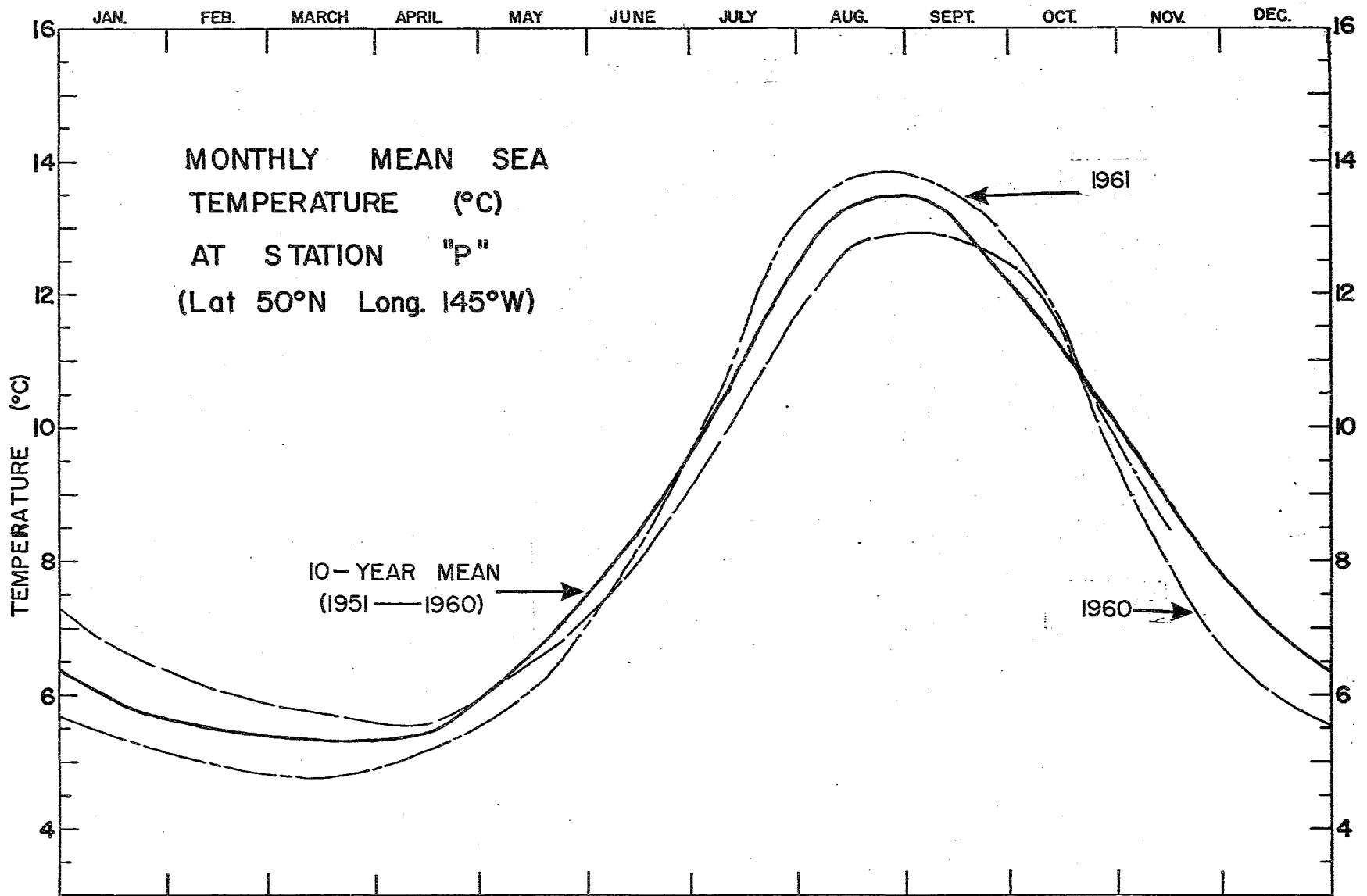

FIGURE 7.

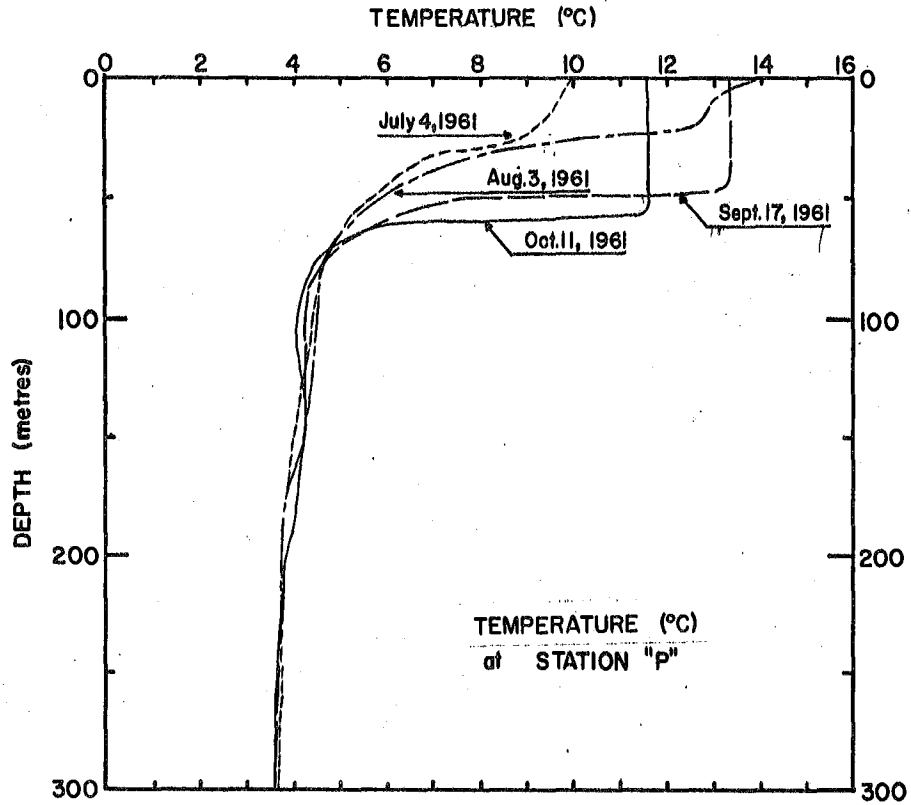

FIGURE 8.

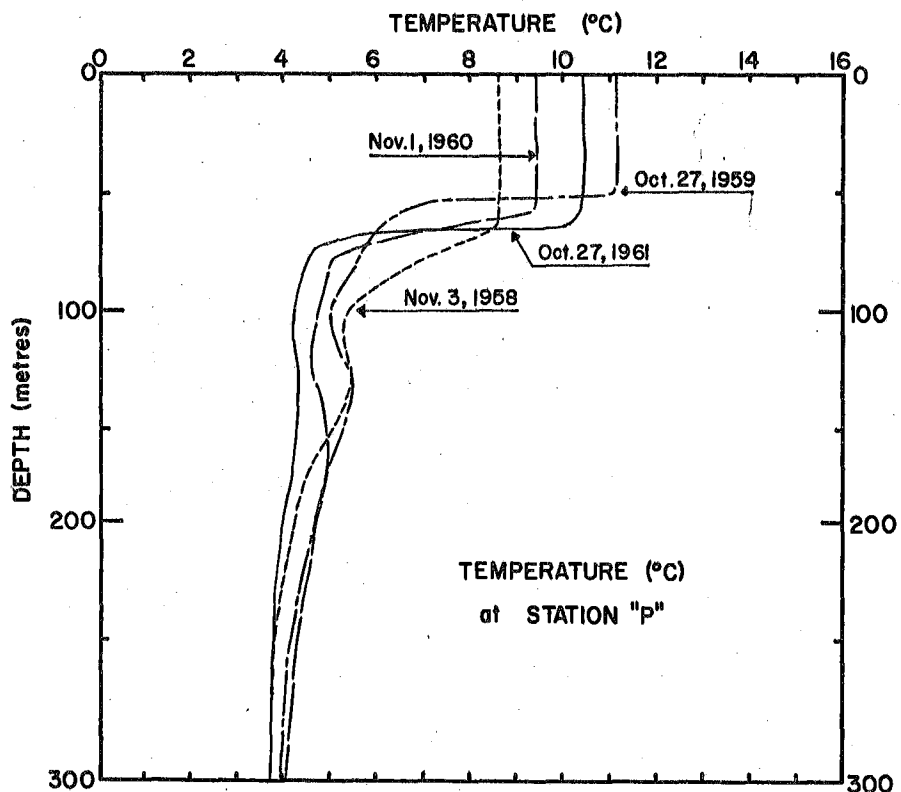

FIGURE 9.

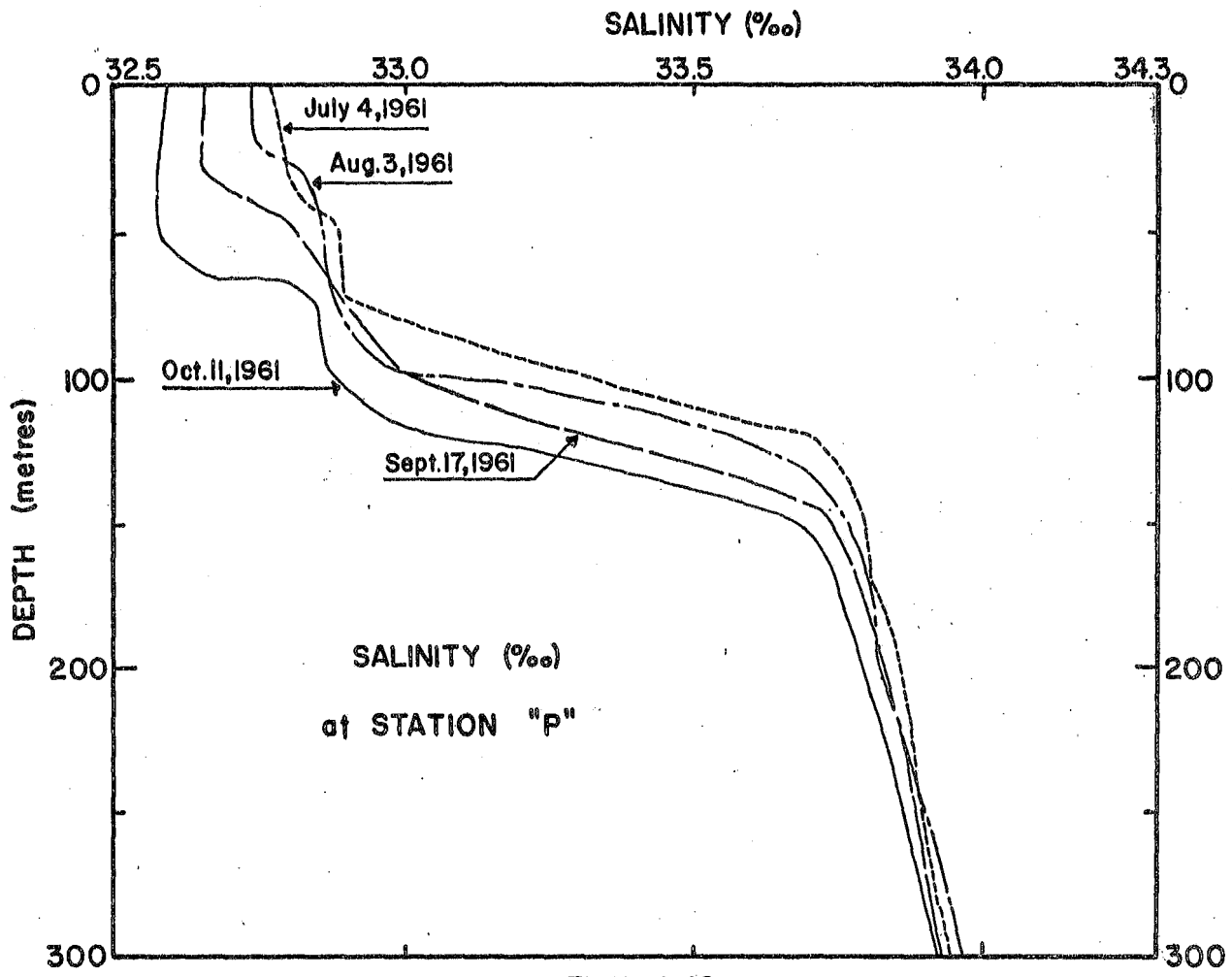

FIGURE 10.

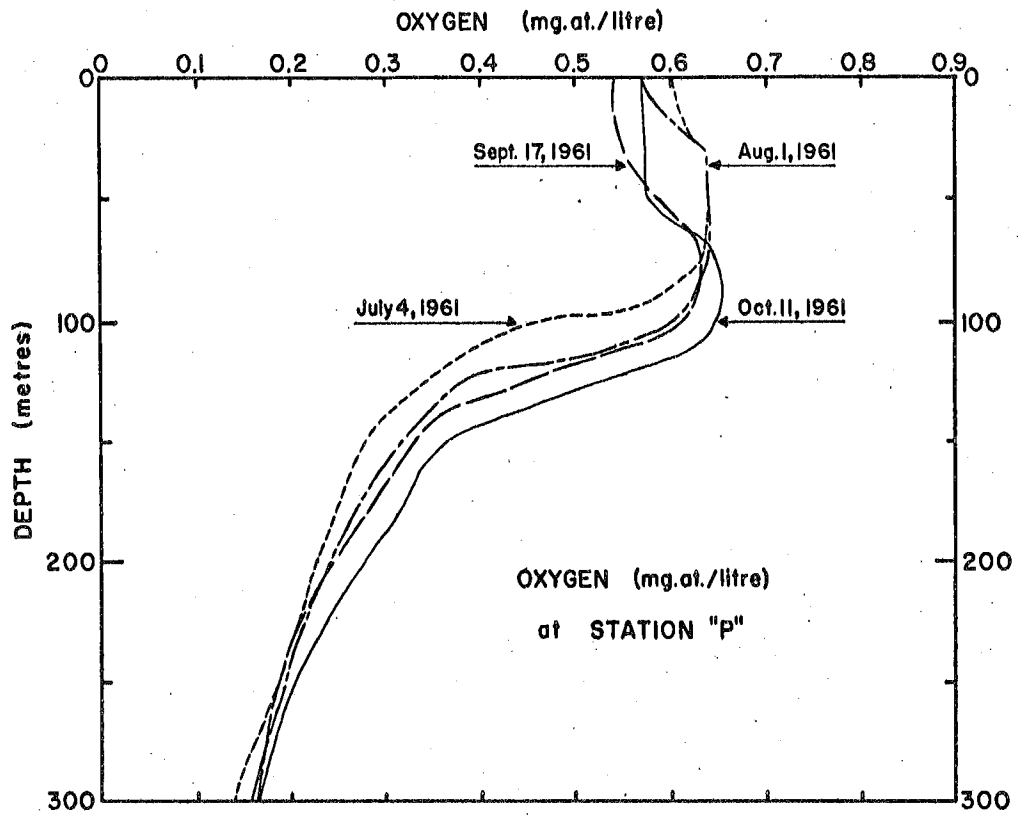

FIGURE 11.

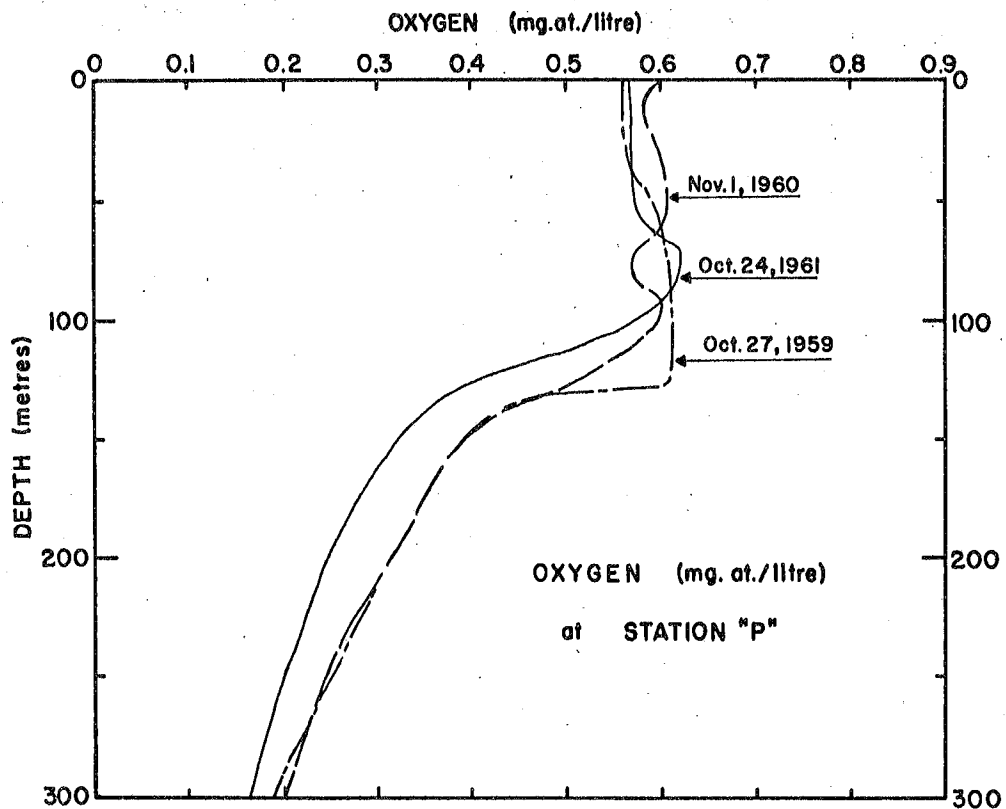

FIGURE 12.

*D. Needler*

FISHERIES RESEARCH BOARD OF CANADA  
Pacific Oceanographic Group  
Nanaimo, B. C.

Circular 1962 - 6  
February 26, 1962

Transport calculations for the North Pacific Ocean  
December 1961

Sverdrup (1947), Stommel (1948), and Munk (1950) have shown that the total steady-state transport of mass in the ocean depends primarily on the curl of the wind stress components acting on the surface of the ocean. Calculations have been performed to estimate the wind stress over the surface of the ocean by computing mean geostrophic winds from pressure differences between grid points, applying a transformation to estimate surface winds and using a "square law" formula to relate wind speeds to surface stresses (Fofonoff, MS, 1961, 1961). The purpose of these calculations is two-fold. First, to find out how long an averaging period is necessary to approach steady-state conditions and second, to gain some idea of the variability, both with latitude and time, of the transport that is imposed on the ocean by the atmosphere.

Detailed descriptions of the method used for evaluating the transports are given in the introduction to the annual volumes of transport computations (Fofonoff, MS, 1960, 1961). The actual computer program for the calculation of mass transport is contained in the program manual M-1 (Fofonoff and Froese, MS, 1960).

Six grid points in regions of special interest have been selected to evaluate the transport components for a given month in terms of mean values. They lie in the Gulf of Alaska (55° N, 155° W), Ocean Station "P" (average values at 50° N, 150° W and 50° N, 140° W), west of California Current (35° N, 135° W), adjacent to the Kuroshio Current (30° N, 160° E), the Oyashio Current (45° N, 155° E), and the Kamchatka Current (50° N, 160° E).

At each grid point the mean values and the standard deviations of the transport components from values for the same month from previous years are given in tabular form. In addition, the mean values of the integrated total and geostrophic transport for the month and eleven preceding months are given and compared with similar averages in previous years to indicate the long term trend of computed transport.

The departures of the monthly values from their means have been divided into three classes in terms of the number of standard deviations from the mean. The classes are:

Class 1: departure of less than one standard deviation from the mean (68% of values for a Gaussian distribution). Values falling in this range are termed "normal".

Class 2: departures of one to two standard deviations from the mean (17% of values for a Gaussian distribution). These values will be referred to as "above normal" or "below normal".

*Needler*

Class 3: departures greater than two standard deviations from the mean (5% of values for a Gaussian distribution). Values whose variation falls in this range will be denoted as "strongly above normal" or "strongly below normal".

#### Transport charts

- I. Monthly mean sea-level atmospheric pressure given as the anomaly of mean atmospheric pressure from 1000 mbs. in units of 1/10 millibars.
- II. Meridional component of Ekman transport ( $V_E$ ) in units of 10 metric tons/km/sec.
- III. Zonal component of Ekman transport ( $U_E$ ) in units of 10 metric tons/km/sec.
- IV. Meridional component of total transport ( $V$ ) in units of 100 metric tons/km/sec.

The values shown on chart IV are  $-V$

- V. Integrated total transport ( $\Psi$ ) in units of 100,000 metric tons/sec.
- VI. Integrated geostrophic transport ( $\Psi_g$ ) in units of 100,000 metric tons/sec.

The convention of signs adopted is that northward and eastward transport shall be considered as positive and southward and westward flow shall be negative.

#### References

- Fofonoff, N.P. MS, 1960. Transport computations for the North Pacific Ocean, 1955-58. Fish. Res. Bd. Canada, MS Rept., Oceanogr. and Limnol. Series, Nos. 77-80, 93 pp.
- MS, 1961. Transport computations for the North Pacific Ocean 1959. Fish. Res. Bd. Canada, MS Rept., Oceanogr. and Limnol. Series No. 85, 181 pp.
- Fofonoff, N.P., and C. Froese. MS, 1960. Programs for oceanographic computations and data processing on the electronic digital computer ALWAC III-E. M-1 miscellaneous programs. Fish. Res. Bd. Canada, MS Rept., Oceanogr. and Limnol. Series, No. 72, 35 pp.
- Munk, W.H. 1950. On the wind-driven ocean circulation. J. Meteorol. 1 (2), 79-93.
- Stommel, H. 1948. The westward intensification of wind-driven ocean currents. Trans. Amer. Geophys. Union 29, (2): 202-206.
- Sverdrup, H.V. 1947. Wind-driven currents in a baroclinic ocean; with applications to the equatorial currents of the Eastern Pacific. Proc. Nat. Acad. Sc., 33 (11): 318-326.

Assessment of transport calculations for December, 1961

Since 1955 the atmospheric pressure field over the North Pacific has shown considerable variability from one December to the next. Generally there is a high pressure area over China and another in the mid-latitudes over the United States or extending out over the ocean. A low pressure area is found between them but its centre will shift from the mid-Pacific to the northeastern edge of the Gulf of Alaska, to the Aleutians and even over the Bering Sea. In December 1961 the high pressure area over China was slightly more intense than in the past. A "high" was also found off the coast of the United States and did not differ appreciably in magnitude from previous years. The low was found slightly south of the Aleutians and was less intense than usual. It was this pressure distribution that gave rise to the water mass transport for the month of December.

The meridional component of Ekman transport was "normal" for the eastern grid points whereas it was "below normal" for the Kuroshio and Oyashio Currents and "strongly above normal" for the Kamchatka Current. The zonal component was "below normal" for the Kamchatka and California Currents and "strongly below normal" for the Oyashio Current.

The meridional component of total transport was "above normal" for the Oyashio Current and "below normal" for the Kamchatka Current.

The integrated total transport for the Kuroshio Current and the integrated geostrophic transport for Ocean Station "P" were both slightly "below normal". The Gulf of Alaska showed "strongly below normal" integrated total and geostrophic transport components.

The trends of integrated total and geostrophic transport were "normal" for all selected grid points.

C.K. Ross.

Table I. A comparison of transport components at selected grid points with the average values for the same month from previous years.

1. Kamchatka Current (50° N, 160° E)							4. Gulf of Alaska (55° N, 155° W)						
Dec 1961	Dec 1960	Dec Mean (55-60)	$\sigma$	$\frac{ x-\bar{x} }{\sigma}$	Class		Dec 1961	Dec 1960	Dec Mean (55-60)	$\sigma$	$\frac{ x-\bar{x} }{\sigma}$	Class	
$V_E$	69	-33	-22.5	23.3	3.92	3	$V_E$	4	16	0.2	34.0	.11	1
$U_E$	-47	-8	-11.2	24.8	1.44	2	$U_E$	-7	32	-10.0	25.7	.12	1
$-V$	-3	-63	-69.8	39.1	1.71	2	$-V$	-75	-126	-108.0	69.9	.47	1
$\Psi$	408	412	443.0	242.5	.14	1	$\Psi$	92	147	252.8	59.3	2.72	3
$\Psi_3$	391	426	461.8	516.1	.14	1	$\Psi_3$	91	142	251.0	60.8	2.64	3
$\bar{\Psi}_3$	202.8	278.6	232.0	36.2	.83	1	$\bar{\Psi}_3$	95.4	87.9	117.2	34.1	.67	1
$\bar{\Psi}_9$	214.5	292.3	246.5	35.0	.91	1	$\bar{\Psi}_9$	95.5	87.8	117.2	34.1	.67	1

2. Oyashio Current (45°N, 155° E)							5. Ocean Station "P" (50° N, 145° W)						
Dec 1961	Dec 1960	Dec Mean (55-60)	$\sigma$	$\frac{ x-\bar{x} }{\sigma}$	Class		Dec 1961	Dec 1960	Dec Mean (55-60)	$\sigma$	$\frac{ x-\bar{x} }{\sigma}$	Class	
$V_E$	-1	-64	-46.5	25.7	1.77	2	$V_E$	-37.0	1	-56.5	60.5	.32	1
$U_E$	-50	-5	-10.2	17.6	2.26	3	$U_E$	22.0	78	53.2	45.3	.69	1
$-V$	-59	-33	-20.5	32.7	1.18	2	$-V$	-47.0	-77	-99.8	58.7	.90	1
$\Psi$	363	145	213.8	339.1	.44	1	$\Psi$	67.5	55	109.2	51.3	.83	1
$\Psi_3$	378	184	262.2	343.7	.34	1	$\Psi_3$	71.0	105	122.3	45.2	1.13	2
$\bar{\Psi}_3$	62.8	25.8	47.0	68.9	.23	1	$\bar{\Psi}_3$	43.3	46.3	33.5	11.2	.88	1
$\bar{\Psi}_9$	92.8	56.5	77.7	68.1	.22	1	$\bar{\Psi}_9$	46.1	53.1	37.3	12.0	.73	1

3. Kuroshio Current (30° N, 140° E)							6. California Current (35° N, 135° W)						
Dec 1961	Dec 1960	Dec Mean (55-60)	$\sigma$	$\frac{ x-\bar{x} }{\sigma}$	Class		Dec 1961	Dec 1960	Dec Mean (55-60)	$\sigma$	$\frac{ x-\bar{x} }{\sigma}$	Class	
$V_E$	-9	-1	2.7	9.7	1.21	2	$V_E$	-17	-23	-28.2	31.0	.36	1
$U_E$	-35	-28	-30.5	15.6	.29	1	$U_E$	-18	33	20.0	23.2	1.64	2
$-V$	-5	-8	0.0	7.2	.70	1	$-V$	52	56	13.3	47.1	.82	1
$\Psi$	-512	-338	-339.7	152.3	1.13	2	$\Psi$	-19	-26	-18.7	12.5	.02	1
$\Psi_3$	-478	-316	-330.7	153.3	.96	1	$\Psi_3$	-18	-25	-17.8	13.9	.01	1
$\bar{\Psi}_3$	-343.1	-257.7	-300.0	45.6	.95	1	$\bar{\Psi}_3$	-37.8	-27.8	-33.3	5.0	.90	1
$\bar{\Psi}_9$	-343.9	-264.4	-306.3	45.3	.83	1	$\bar{\Psi}_9$	-35.8	-26.5	-31.5	5.1	.84	1

Explanation of table:

$\sigma$  is based on (55-60) values

$\frac{|x-\bar{x}|}{\sigma}$  denotes deviation from mean in terms of standard deviation

$\bar{\Psi}, \bar{\Psi}_3$  are trends of integrated transports based on the straight mean of the month and the eleven preceding months

Classes are explained on pages 1-2.

Dec 1 Dec 30 1961

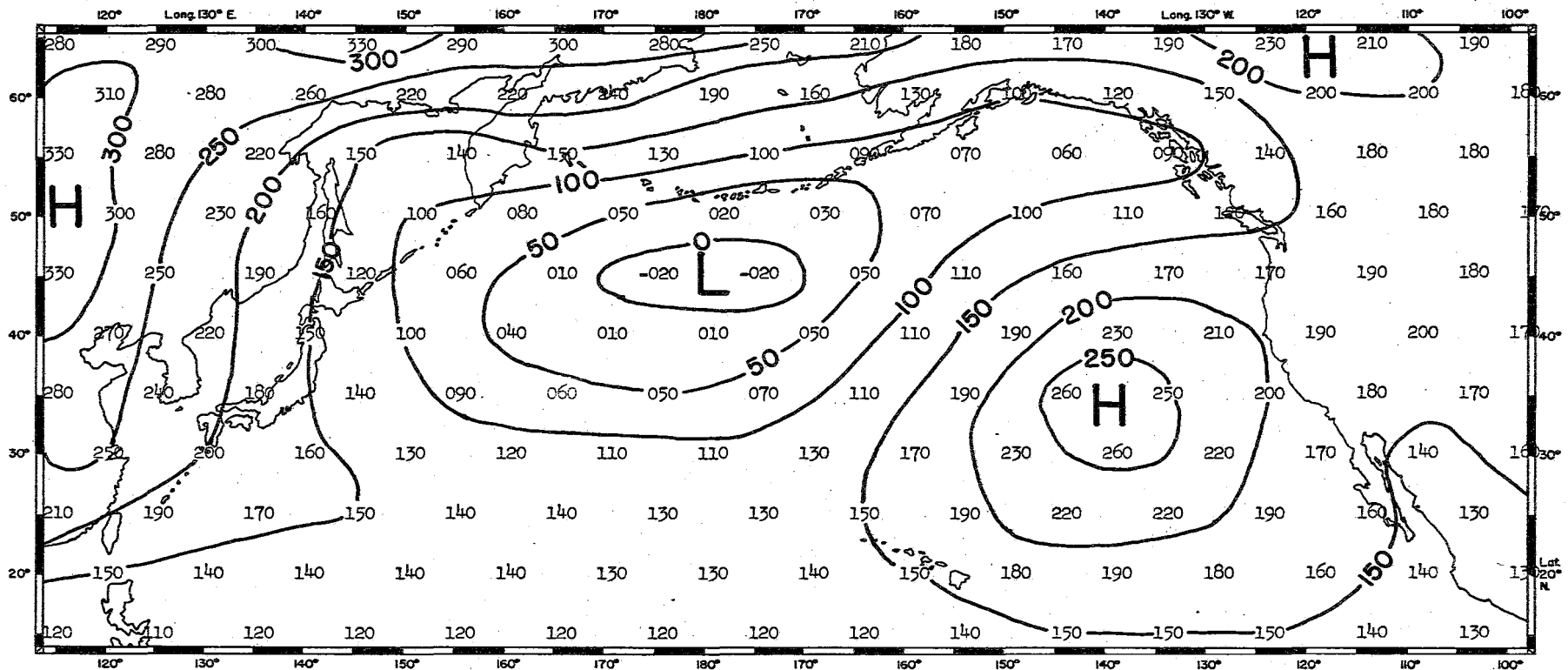

I. Atmospheric Pressure

Dec 1 Dec 30 1961

Dec 1 Dec 30 1961

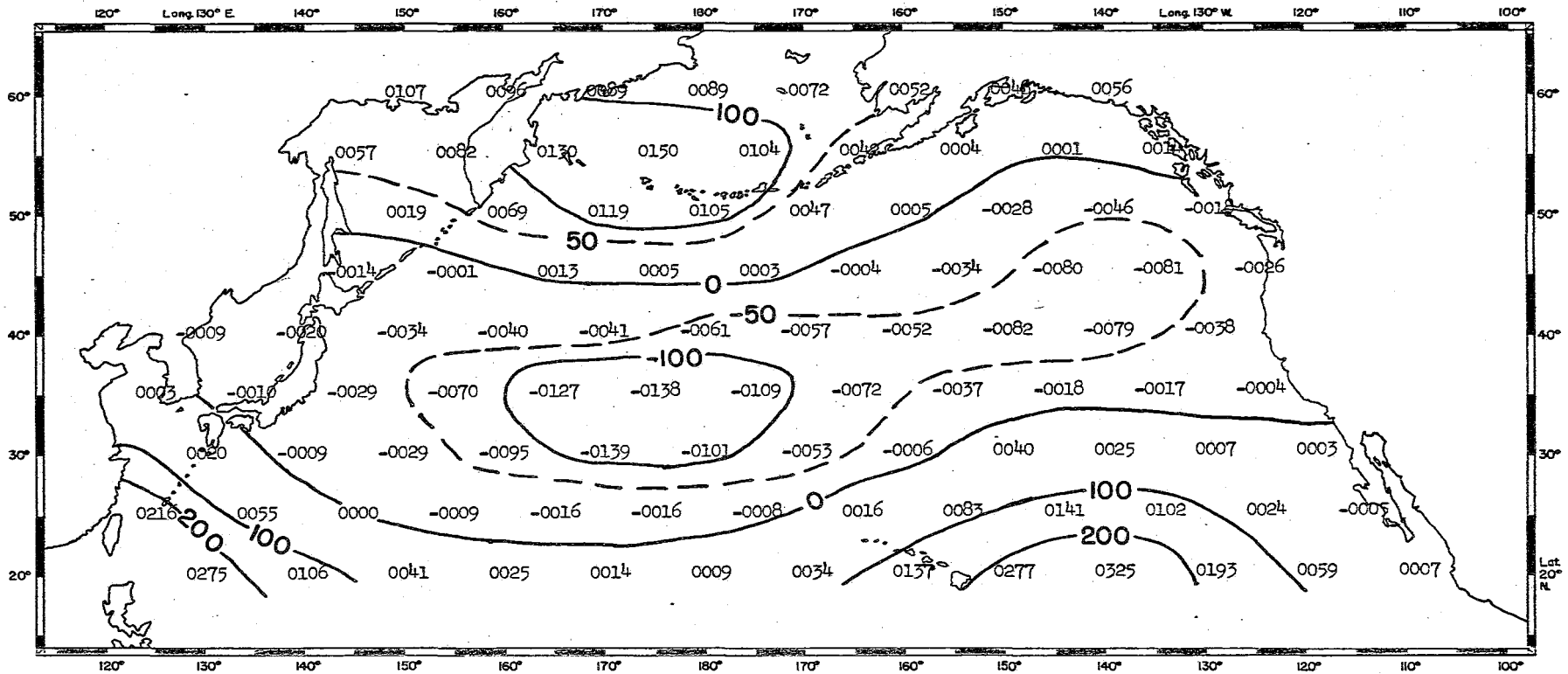

II. Meridional Component of Ekman Transport

Dec 1 Dec 30 1961

Dec 1 Dec 30 1961

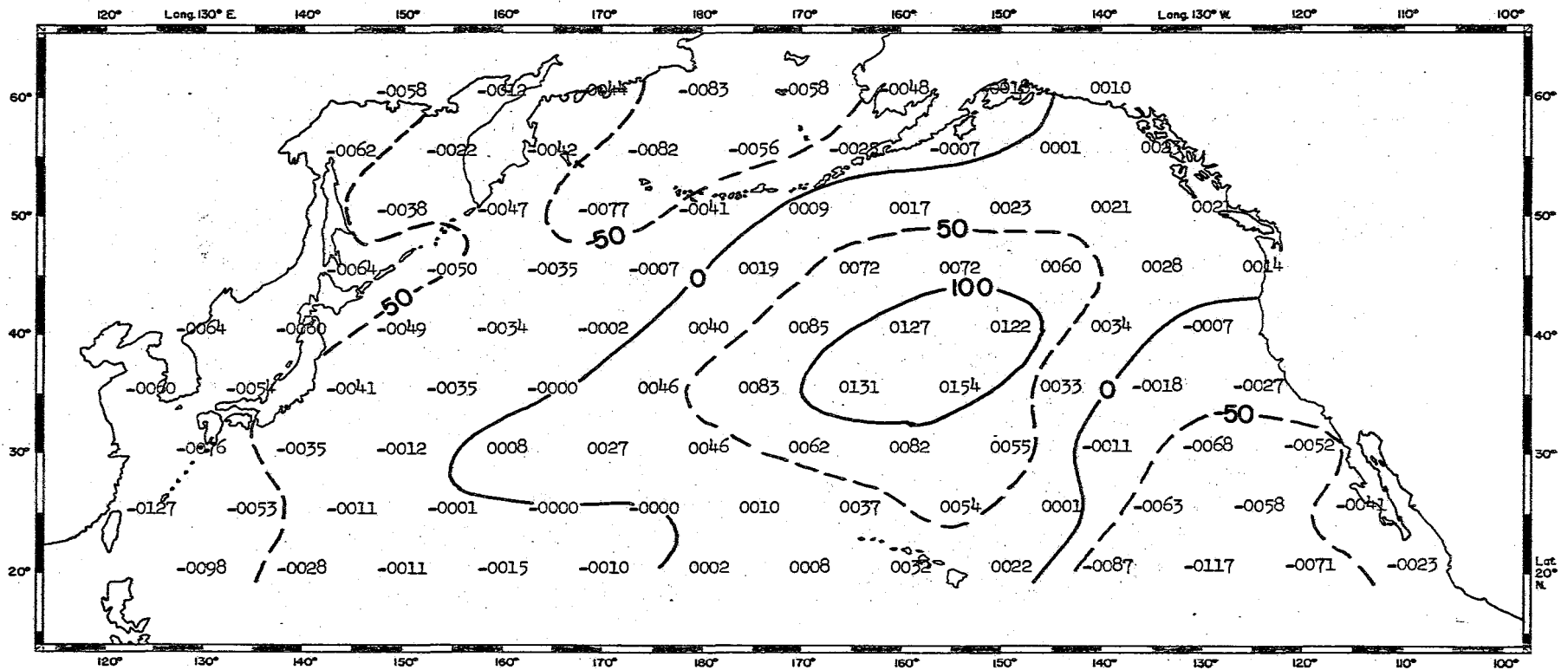

III. Zonal Component of Ekman Transport

Dec 1 Dec 30 1961

Dec 1 Dec 30 1961

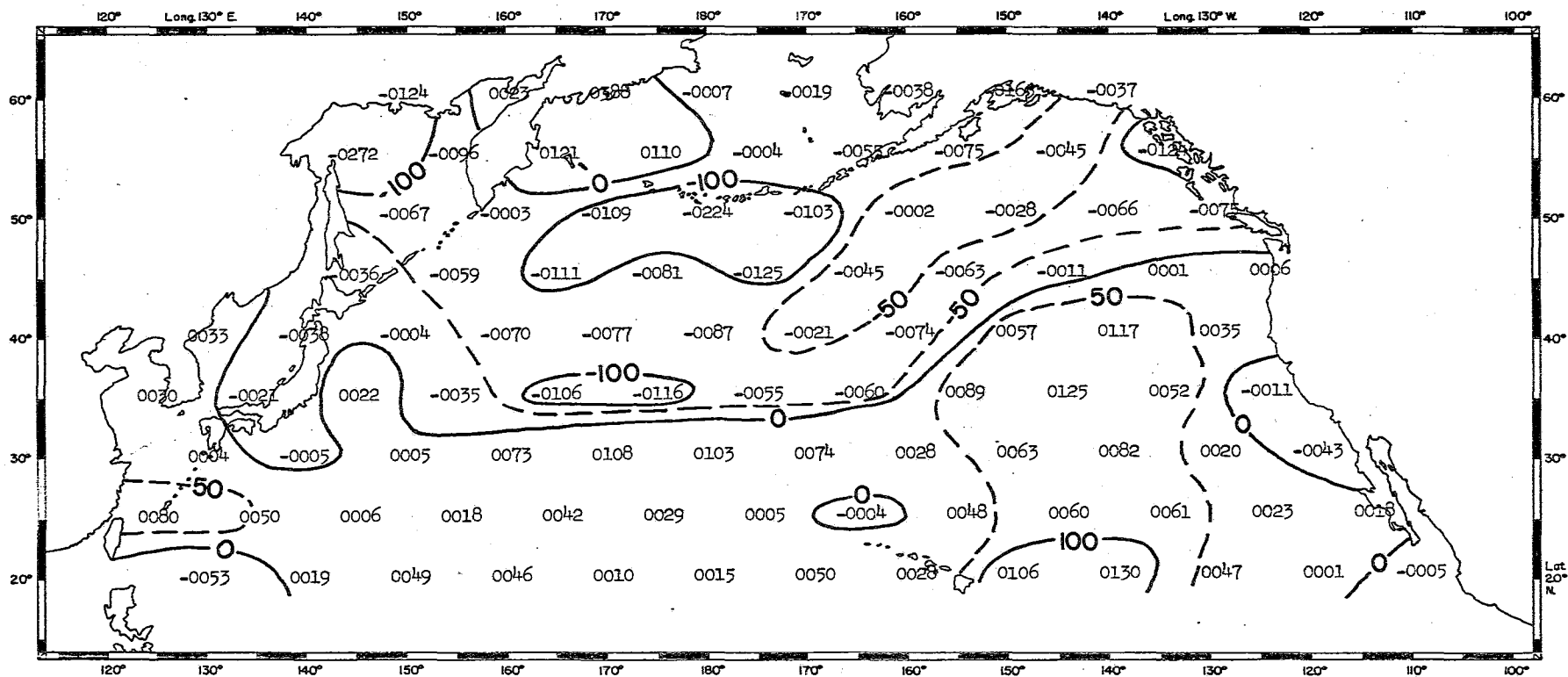

IV. Meridional Component of Total Transport

Dec 1 Dec 30 1961

Dec 1 Dec 30 1961

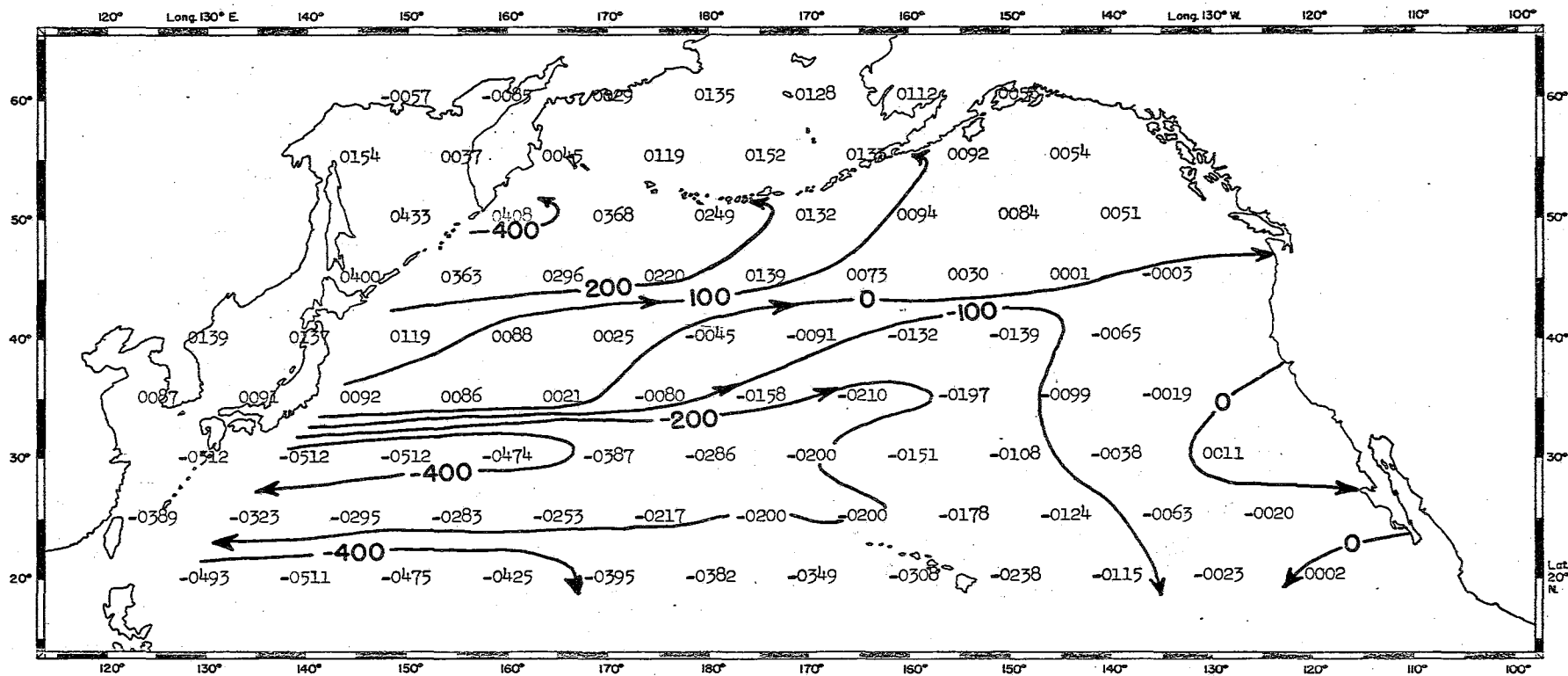

V. Integrated Total Transport

Dec 1 Dec 30, 1961

Dec 1 Dec 30 1961

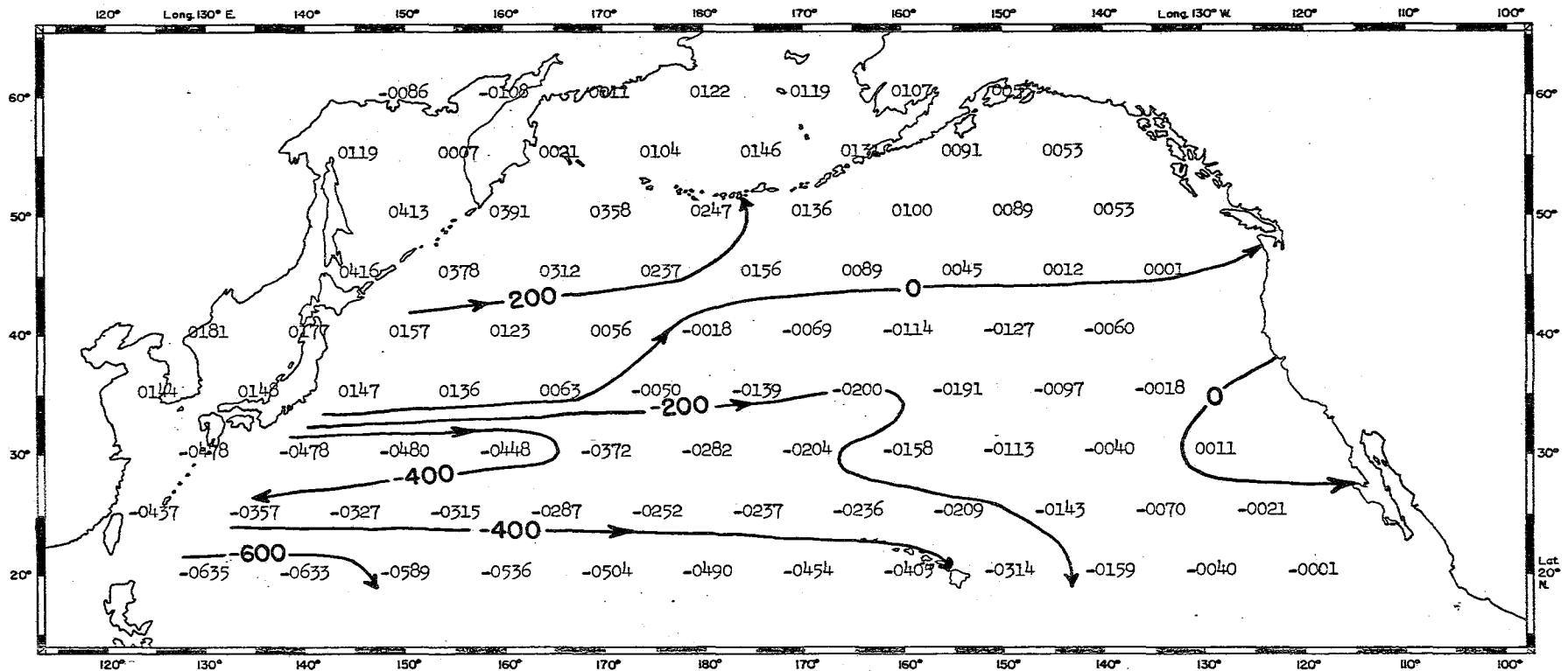

VI. Integrated Geostrophic Transport

Dec 1 Dec 30, 1961

### MERIDIONAL COMPONENT OF EKMAN TRANSPORT in 10 metric tons/second/kilometer

FIG 1

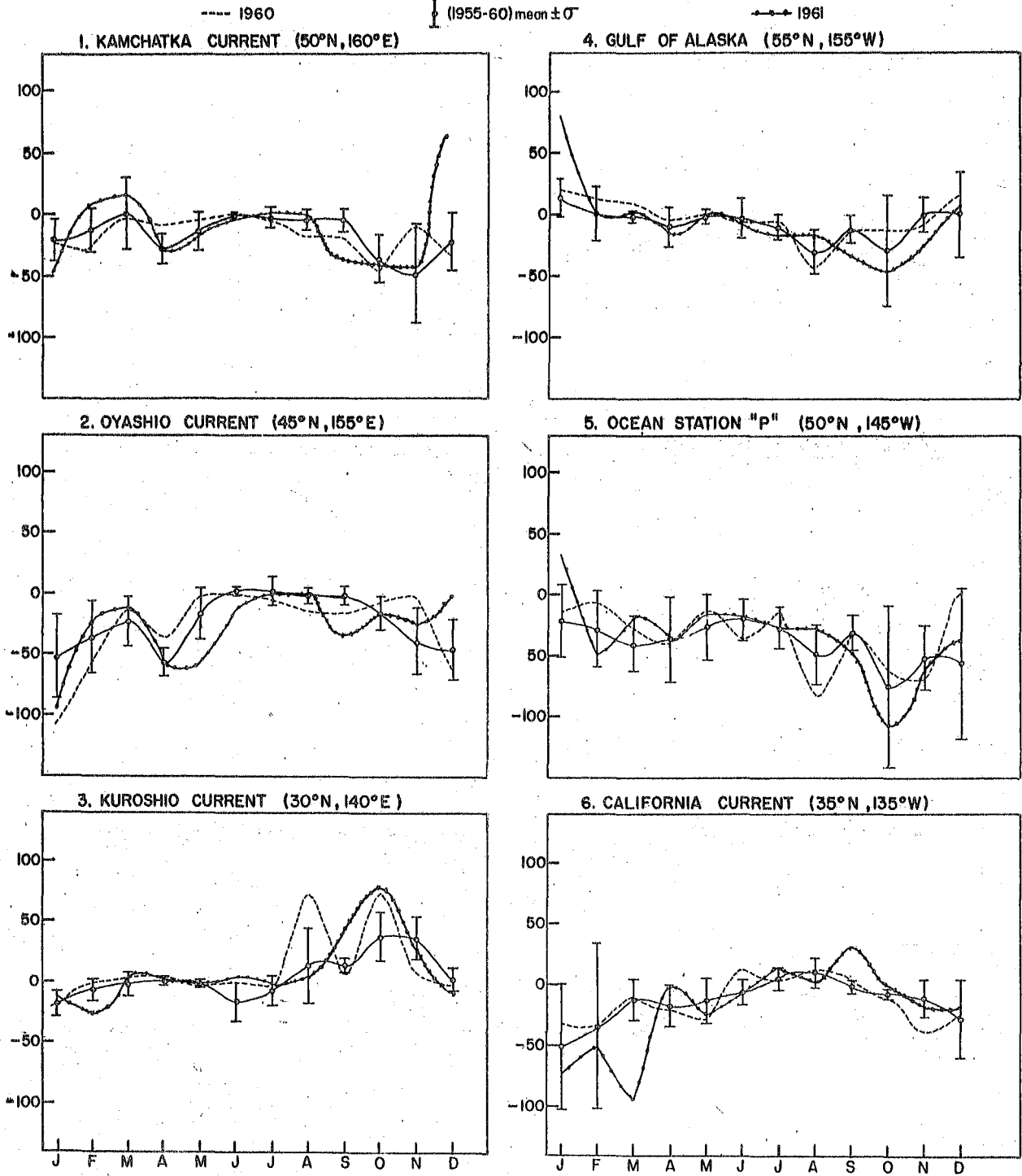

**FIG 2 ZONAL COMPONENT OF EKMAN TRANSPORT**  
in 10 metric tons / second / kilometer

----- 1960

(1955-60) mean  $\pm \sigma$

--- 1961

**1. KAMCHATKA CURRENT (50°N, 160°E)**

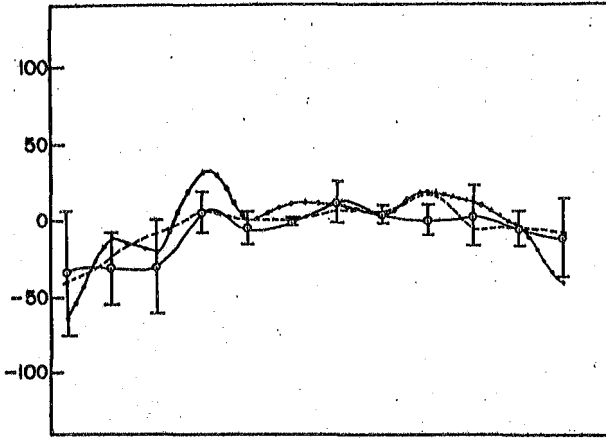

**4. GULF OF ALASKA (55°N, 155°W)**

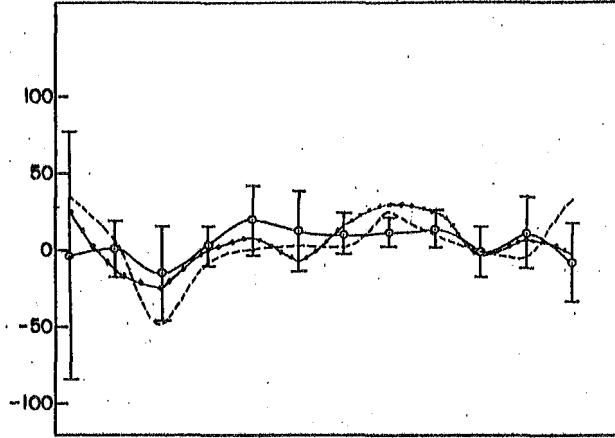

**2. OYASHIO CURRENT (45°N, 155°E)**

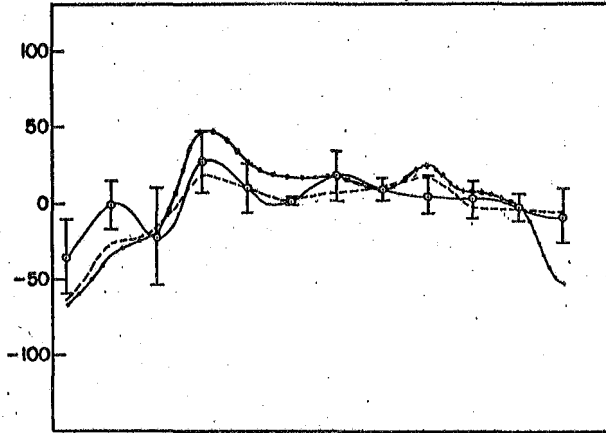

**5. OCEAN STATION 'P' (50°N, 145°W)**

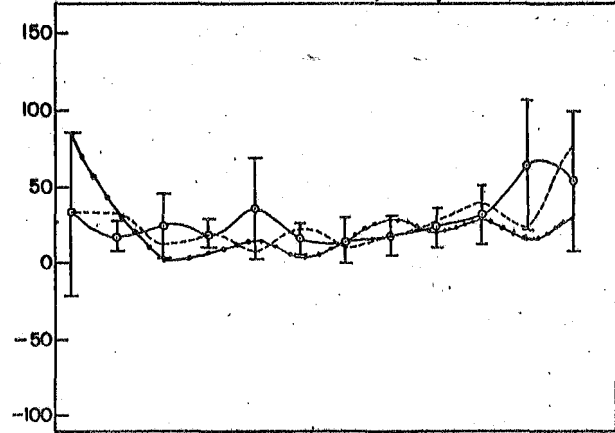

**3. KUROSHIO CURRENT (30°N, 140°E)**

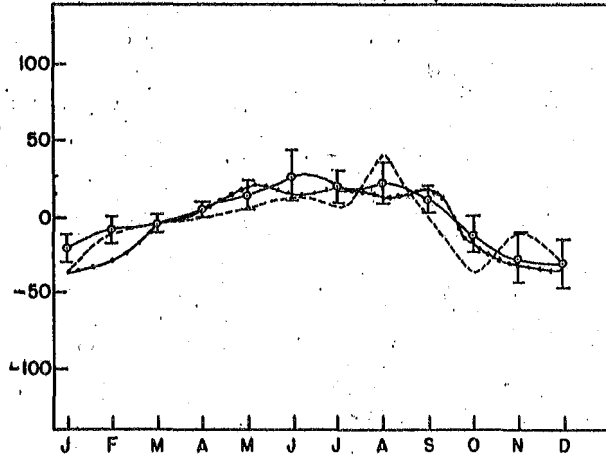

**6. CALIFORNIA CURRENT (35°N, 135°W)**

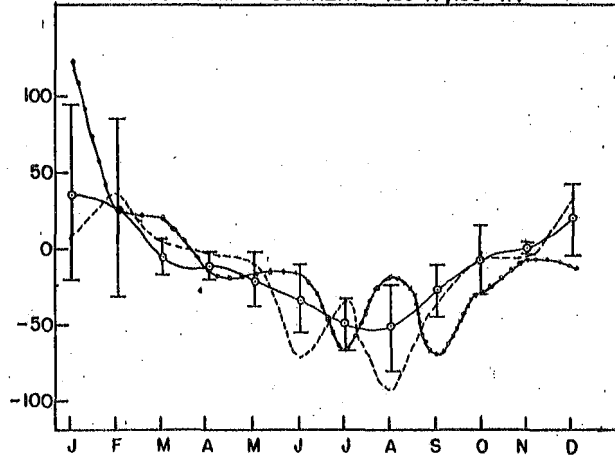

**FIG. 3** MERIDIONAL COMPONENT OF TOTAL TRANSPORT  
100 metric tons/second/kilometre

---- 1960

○ (1955-60) mean ± σ

— 1961

**1. KAMCHATKA CURRENT (50°N, 160°E)**

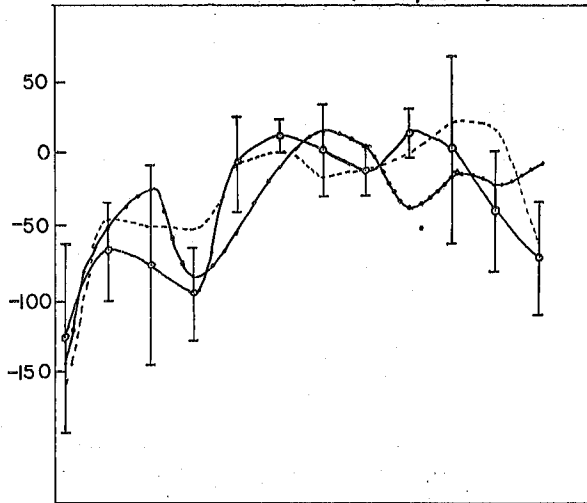

**4. GULF OF ALASKA (55°N, 155°W)**

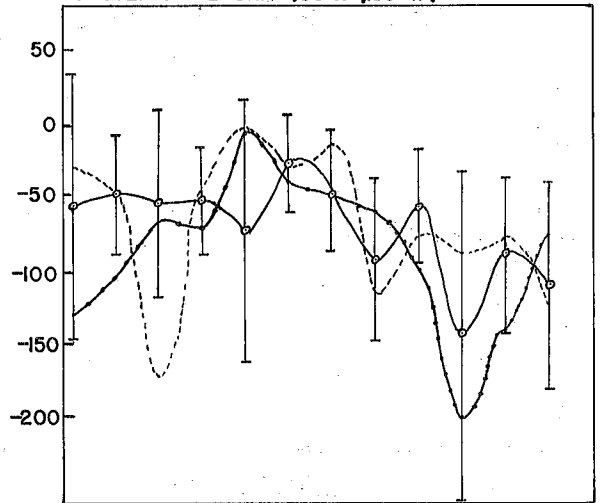

**2. OYASHIO CURRENT (45°N, 155°E)**

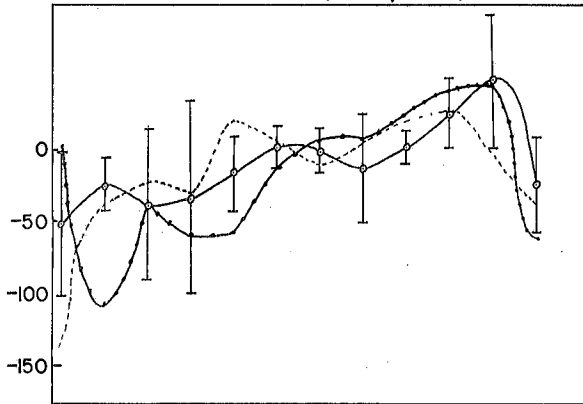

**5. OCEAN STATION "P" (50°N, 145°W)**

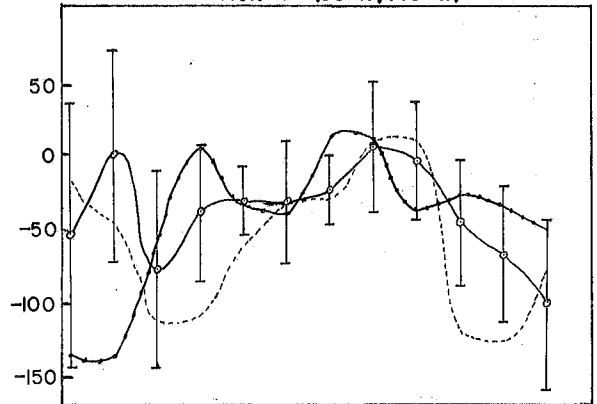

**3. KUROSHIO CURRENT (30°N, 140°E)**

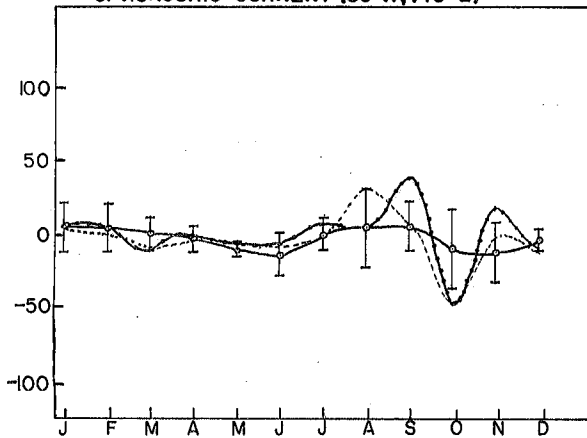

**6. CALIFORNIA CURRENT (35°N, 135°W)**

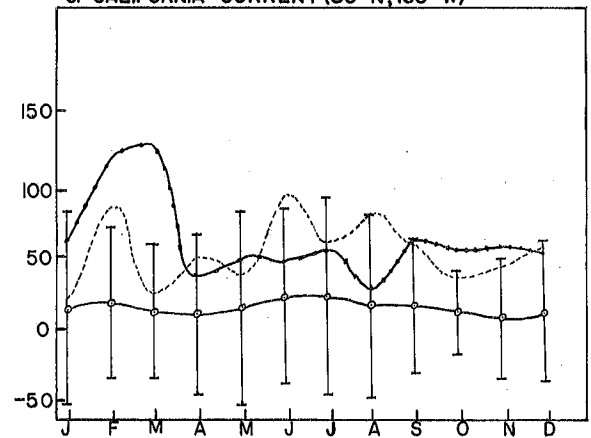

FIG. 4 INTEGRATED TOTAL TRANSPORT  
in millions of metric tons /second.

---- 1960

○ (1955-60) mean ± σ

--- 1961

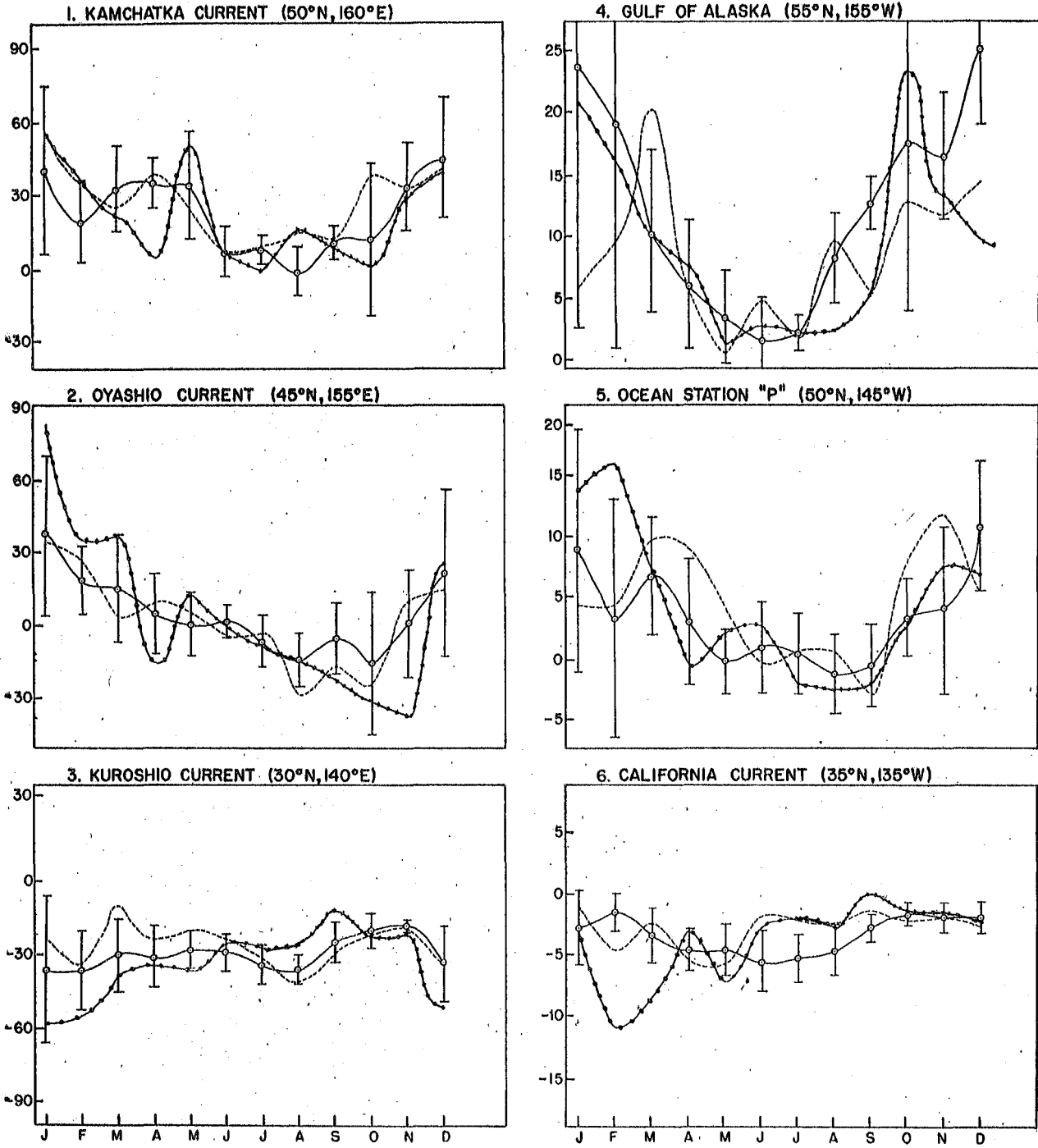

FIG 5 INTEGRATED GEOSTROPHIC TRANSPORT  
in millions of metric tons/second

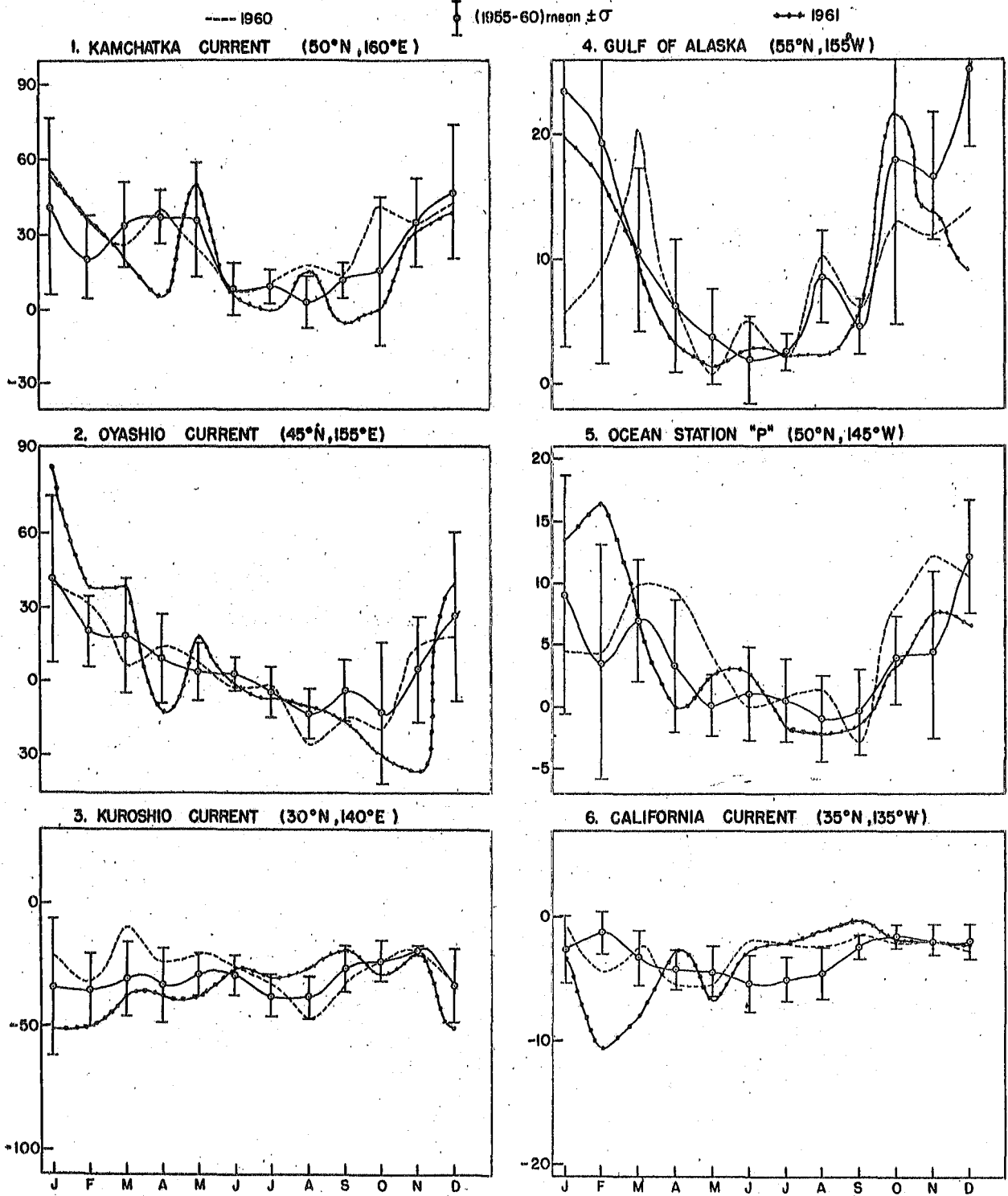

FIG. 6 TREND OF INTEGRATED TOTAL TRANSPORT  
in millions of metric tons/second

----- 1960

⊥ (1955-60) mean ± σ

---●--- 1961

1. KAMCHATKA CURRENT (50°N,160°E)

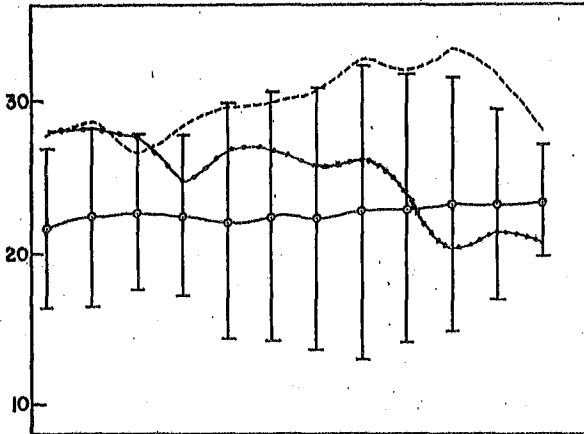

4. GULF OF ALASKA (55°N,155°W)

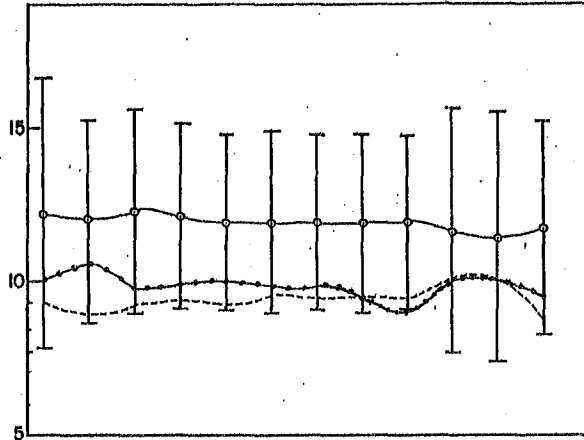

2. OYASHIO CURRENT (45°N,155°E)

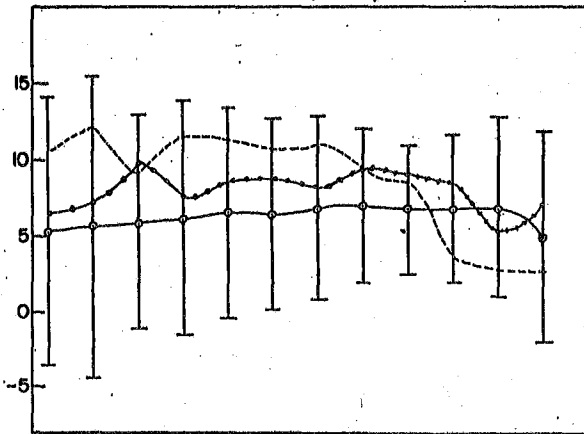

5. OCEAN STATION "P" (50°N,145°W)

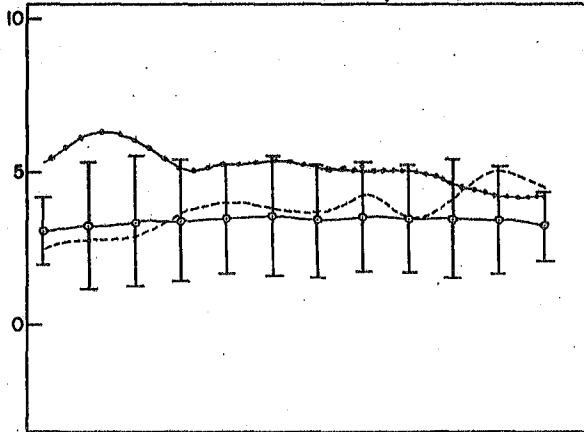

3. KUROSHIO CURRENT (30°N,140°E)

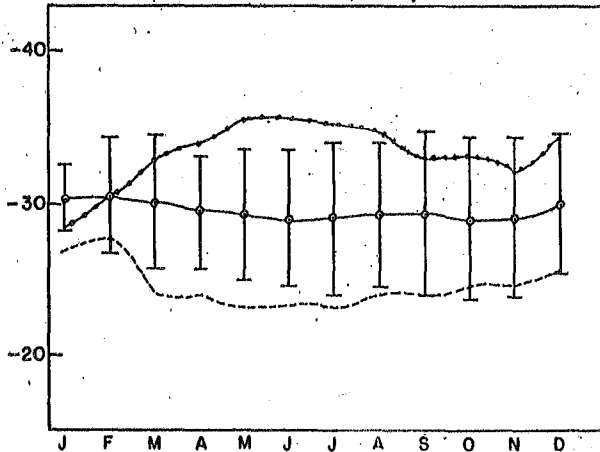

6. CALIFORNIA CURRENT (35°N,135°W)

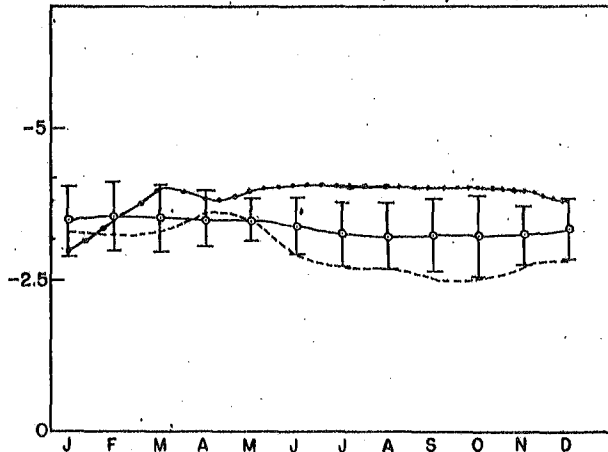

**FIG. 7** TREND OF INTEGRATED GEOSTROPHIC TRANSPORT  
in millions of metric tons / second

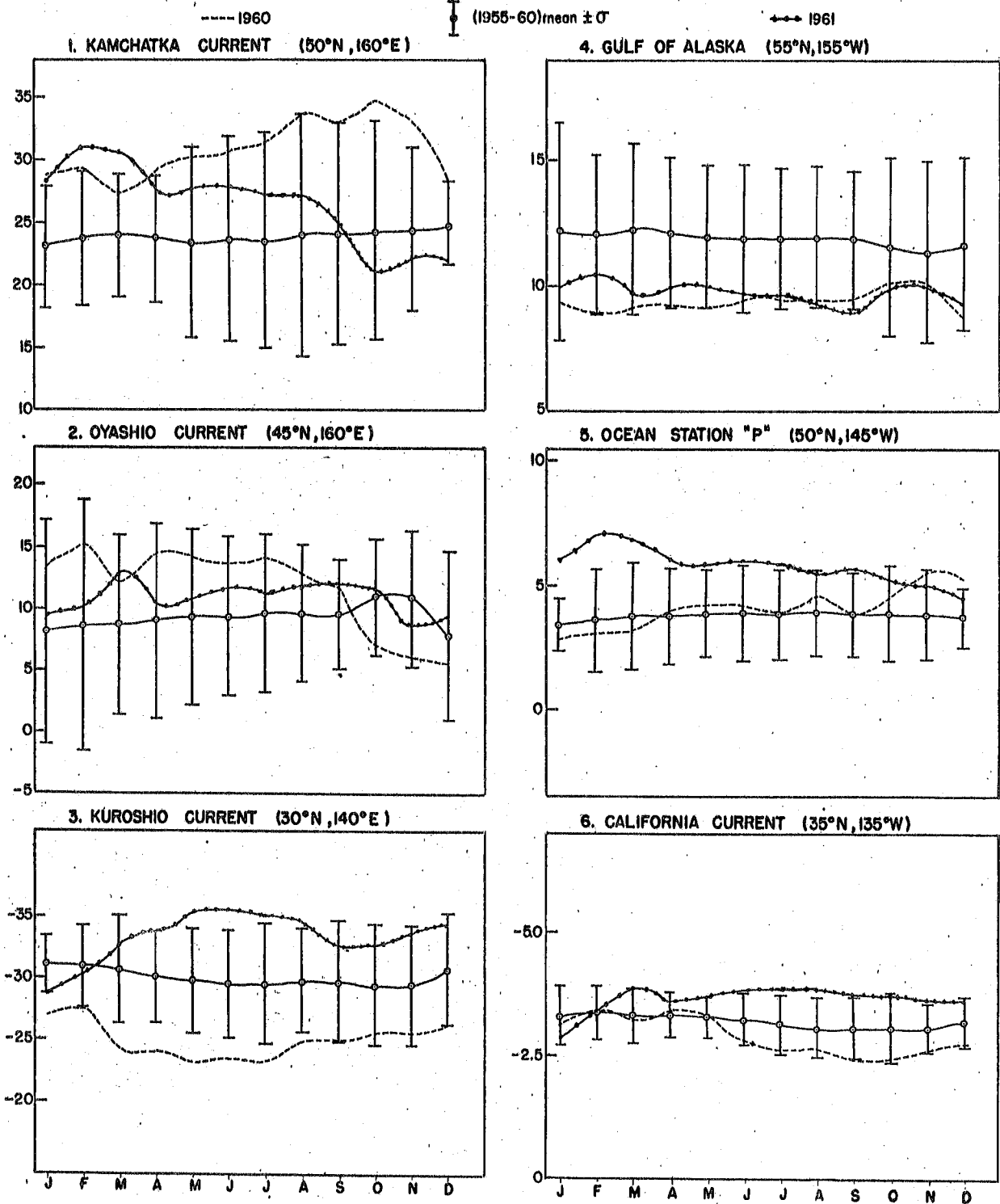

*Dr. Needler*

FISHERIES RESEARCH BOARD OF CANADA  
Pacific Oceanographic Group  
Nanaimo, B. C.

Circular 1962 - 7  
March 12, 1962.

Oceanographic observations from the Weathership C.M.S. "St. Catharines"  
Cruise P-61-5, December 5, 1961-January 22, 1962

Introduction

Oceanographic observations are made from C.M.S. "St. Catharines" at Ocean Station "P" (Fig. 1) through alternate six-week periods, and en route to and from the station. To monitor the oceanographic conditions from surface to bottom, bathythermograms are taken twice daily. Serial oceanographic observations from the surface to 2000 m depth are made twice weekly on station. Observations are made to the bottom once a week. These samples are analyzed for temperature, salinity and dissolved oxygen and silicates. In addition special observations are made to observe internal waves, radiation, plankton, bio-productivity, drift, sea life, etc.

This circular summarizes the temperature data observed during the period December 5-8, 1961 to January 19-21, 1962.

Temperatures in the line "S" - "P" section

(a) At 3 metre depth

Continuous records of temperature at 3 m depth were obtained from a temperature sensing element at the engineroom seawater intake. This thermograph along line "S" - "P" is reproduced in Fig. 2. The upper trace corresponds to observations taken during Dec 5-8, 1961 and the lower one to Jan 18-21, 1962. These values were found to correspond to the temperatures observed with reversing thermometers at 10 m depth, with  $\pm 0.2$  C°.

On comparing the temperature records in Fig. 2, it was noticed that the average decrease in surface water temperature during the seven week period was about 1.5° C. Station 3 and Swiftsure were the two regions where the most marked cooling occurred. This marked cooling (2.5° C) brought about the complete disappearance of the former warm region at Station 3 and also created a sharp decrease in temperature near the coast.

During the earlier period (Dec 5-8, 1961) the surface temperature varied irregularly between Swiftsure and Station 4A. Using a base line of 9° C for the above segment of line "S" - "P", three relatively warm regions were evident. The most significant of these was in the vicinity of Station 3. The two others were at Station 1 and at a position between Stations 4 and 4A. From Station 4A, the temperature decreased irregularly to Station "P". Between Station 6 and "P", the surface water was considerably cooler than the adjacent regions.

In the thermograph record of January 18-21, 1962, there was a rapid increase in temperature from "Swiftsure" to a position a little short of Station 1. From here to a position between 4 and 4A, the temperature was relatively constant

except for a region of colder water at Station 2. From a position between Stations 4 and 4A, to Station "P" the temperature decreased very irregularly.

(b) Vertical distribution of temperature

The depths of the top of the seasonal thermocline (Potential Layer Depth) were determined from a single bathythermogram. Therefore the depth of these values should be viewed with some caution owing to the possible effects of internal waves (Fig. 3). In most cases the surface layer was truly isothermal. Only few possibly "transient thermoclines" were apparent as shown by the symbols \* and  $\Delta$  (bathythermograms were drawn at selected positions to facilitate a further interpretation of the figure).

On comparing the two sets of observations, the usual deepening of the thermocline during the seven week interval was observed in all but three positions. At Stations 2, 4A and "P", the top of the thermocline remained at the same depth. A temperature inversion had replaced the former negative or normal thermocline at Stations 2 and 4A. At Station "P", the magnitude of the thermocline had been reduced from 2.5° C to 1.0° C. The three other positions of interest are at Station 1, between Station 3 and 4, and between Station 5 and 6. At these positions the thermocline appeared to have deepened markedly.

Figures 4a and 4b show isotherms, temperature inversions, and isothermal layers, that were recorded along the line during Dec 5-8, 1961 (in Fig. 4a, the isotherms were drawn 1° C apart; and in Fig. 4b, the isotherms were 0.5° C apart and the depth scale was contracted). It was evident from these temperature contours between 100 and 300 m depth (Fig. 4a) that colder water, relative to adjacent regions occurred in the vicinity of Station 5 and between Station "P" and 6. Otherwise, the ocean temperature increased gradually toward Swiftsure. Below 300 m (Fig. 4b), there was a very gradual increase in temperature from Station "P" to Station 1.

Figures 5a and 5b present data that was taken Jan 18-21, 1962. Both figures showed that at almost all depths there was a steady increase in temperature from Station "P" to Station 1.

The positions and depths of temperature inversions and isothermal layers are identified in the Fig. 4a and 5a. As a point of interest, the large bands of persistent inversions were most often a feature of the colder zones.

Figure 6 shows the difference between temperatures observed during the previous patrol (Oct 27-30, 1961) along line "S" - "P" and those taken on the outbound portion of the present cruise (Dec 5-8, 1961). The magnitude of surface layer cooling is perhaps the most significant feature of this diagram. The other feature is the substantial warming evident just below the thermocline at Station 1 and Station 5.

In Fig. 7, the extent of seasonal cooling of the surface layer again dominated the picture. Two other features in the figure warrant attention. At Station 1, there was a conspicuous decrease of the subthermocline warming conditions that were evident in Fig. 6. At Station 2, a significant warming zone appeared with its nucleus at 360 m and extending as far down as 1000 m.

### Temperatures at Ocean Station "P"

In Fig. 8, the 10-year monthly mean surface sea temperatures (1951-1960) and the monthly mean surface sea temperatures of 1960 are presented for comparison with the recent monthly mean surface sea temperatures. All but the month of December had been plotted and discussed in previous circulars. In December the monthly mean surface sea temperature was 6.5° C. This value is 0.5° C colder than the corresponding temperature of the 10-year mean and 0.5° C warmer than last year's mean.

Figure 9 shows the thermograph temperature records at the 3 m depth, the depths of the top and bottom of the thermoclines from the two daily bathythermograms, and the maximum and minimum wind speeds of the day.

The vertical extent of the thermocline may well be an indication of the relative strength of the vertical mixing processes. It is possible that there are other factors influencing this vertical dimension of the thermocline, such as phase differences in the internal waves at the top and bottom of the thermocline and the horizontal velocity shear of the drift current.

The maximum and minimum wind speeds (knots) were included in Fig. 9. From a cursory examination of the data, no obvious relationship was seen between wind speed and the rates of temperature change in the mixed layer or between the wind speed and the depth of the thermocline.

Temperature values at selected depths for each of the thirteen oceanographic stations taken at Station "P", are listed in Table 1. Temperatures in the top 100 m were influenced mainly by surface seasonal effects. However, Station 507 (Table 1) showed a substantial increase in temperature from that observed two days previously. A condition which could only be attributed to advective influence. Between 100 and 1500 m depth, temperature changes were small and random. Below 1500 m, the data from all five of the very deep stations showed that there were no significant changes in temperature. Previous examination of the thermometers showed that the instrument error had a standard deviation of  $\pm 0.015^\circ$  C. Therefore, a significant change was defined as a temperature difference greater than  $0.03^\circ$  C.

Studies of Station "P" data, from 1956 through 1960, currently being made suggests a two year cycle of the temperatures in the 100 to 700 m depth range. During the five years, the highest temperatures in the two-year cycle occurred in early 1958 and early 1960. If such a two-year cycle could be considered real, another peak in temperature at Station "P" between 100 to 700 m depth should appear before the middle of this year.

### Chemical observations

The results of the oxygen and silicate analysis carried out at Ocean Station "P" indicated that the values were similar at all depths during the six weeks (Dec 8, 1961-Jan 18, 1962).

### Marine observations

One handsaw fish was caught at Station "P" and its internal organs were brought back to the Biological Station. Three other marine organisms were collected at Station "P" and brought back.

Table 1. Temperatures (C°) at selected depths at Ocean Station "P" (9 December 1961 through 17 January 1962)

Date	Station No.	Depth (metres)								
		10	50	100	150	200	250	300	500	750
9/12/62	501	6.99	6.72	5.72	3.86	4.10	3.87	3.75	3.52	3.26
12/12/61	502	6.68	6.61	4.25	4.15	4.13	3.92	3.80	-	-
14/12/61	503	6.68	6.42	4.53	4.15	4.02	3.84	3.76	3.57	3.29
18/12/61	504	6.42	6.42	4.37	4.13	4.10	3.87	3.74	-	-
20/12/61	505	6.32	6.33	4.31	4.21	4.05	3.85	3.76	-	-
25/12/61	506	6.00	6.02	4.01	4.09	4.11	3.79	3.72	3.56	3.23
27/12/61	507	6.17	6.17	3.94	4.15	4.07	3.87	3.77	-	-
1/1/62	508	6.07	6.06	4.17	4.18	4.08	3.86	3.75	3.62	3.30
5/1/62	509	5.95	5.95	4.36	4.33	4.05	3.90	3.77	-	-
9/1/62	510	5.93	5.93	4.21	4.31	4.02	3.86	3.77	3.56	3.25
12/1/62	511	5.89	5.90	4.46	4.30	4.13	3.90	3.82	3.59	3.23
15/1/62	512	5.82	5.83	4.63	4.35	4.05	3.95	3.81	-	-
17/1/62	513	5.59	5.57	4.22	4.05	4.00	3.96	3.82	3.54	3.25

Date	Station No.	Depth (metres)					
		1000	1500	2000	2500	3000	4000
9/12/61	501	2.90	2.30	-	-	-	-
12/12/61	502	-	-	-	-	-	-
14/12/61	503	2.91	2.32	1.95	1.76	1.62	-
18/12/61	504	-	-	-	-	-	-
20/12/61	505	-	-	-	-	-	-
25/12/61	506	2.86	2.30	1.93	1.74	1.62	1.52
27/12/61	507	-	-	-	-	-	-
1/1/62	508	2.87	2.31	1.94	1.71	1.61	1.52
5/1/62	509	-	-	-	-	-	-
9/1/62	510	2.88	2.32	1.95	1.75	1.63	1.51
12/1/62	511	2.89	2.31	-	-	-	-
15/1/62	512	-	-	-	-	-	-
17/1/62	513	2.89	2.36	1.97	1.74	1.63	1.51

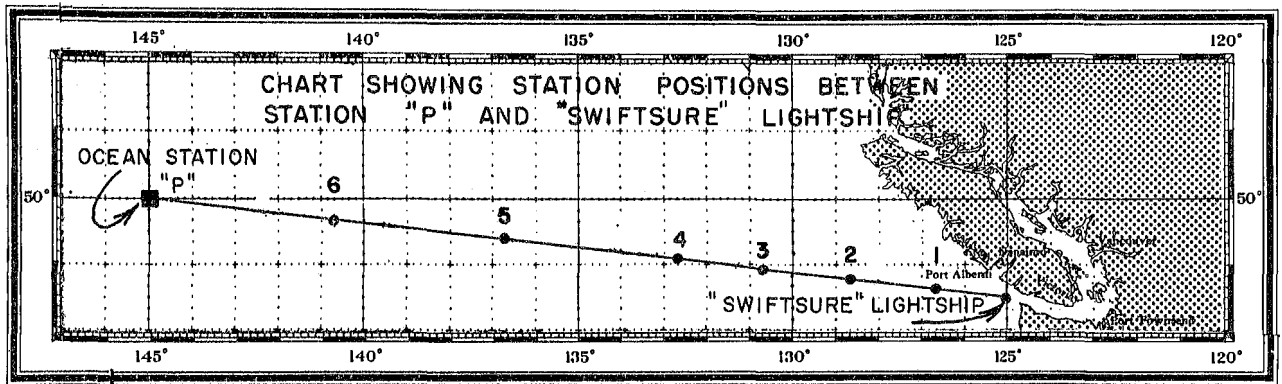

Figure 1.

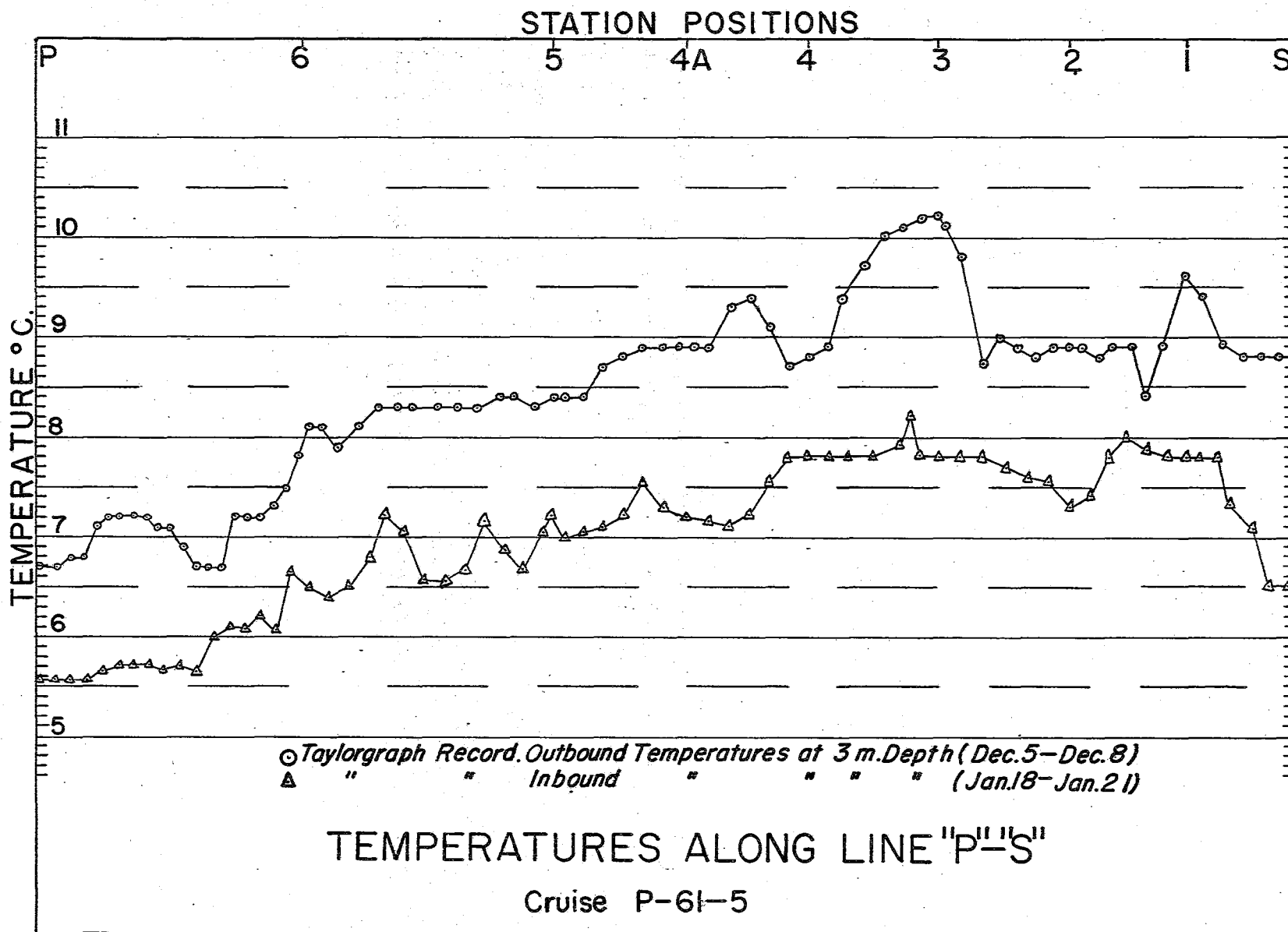

FIGURE 2.



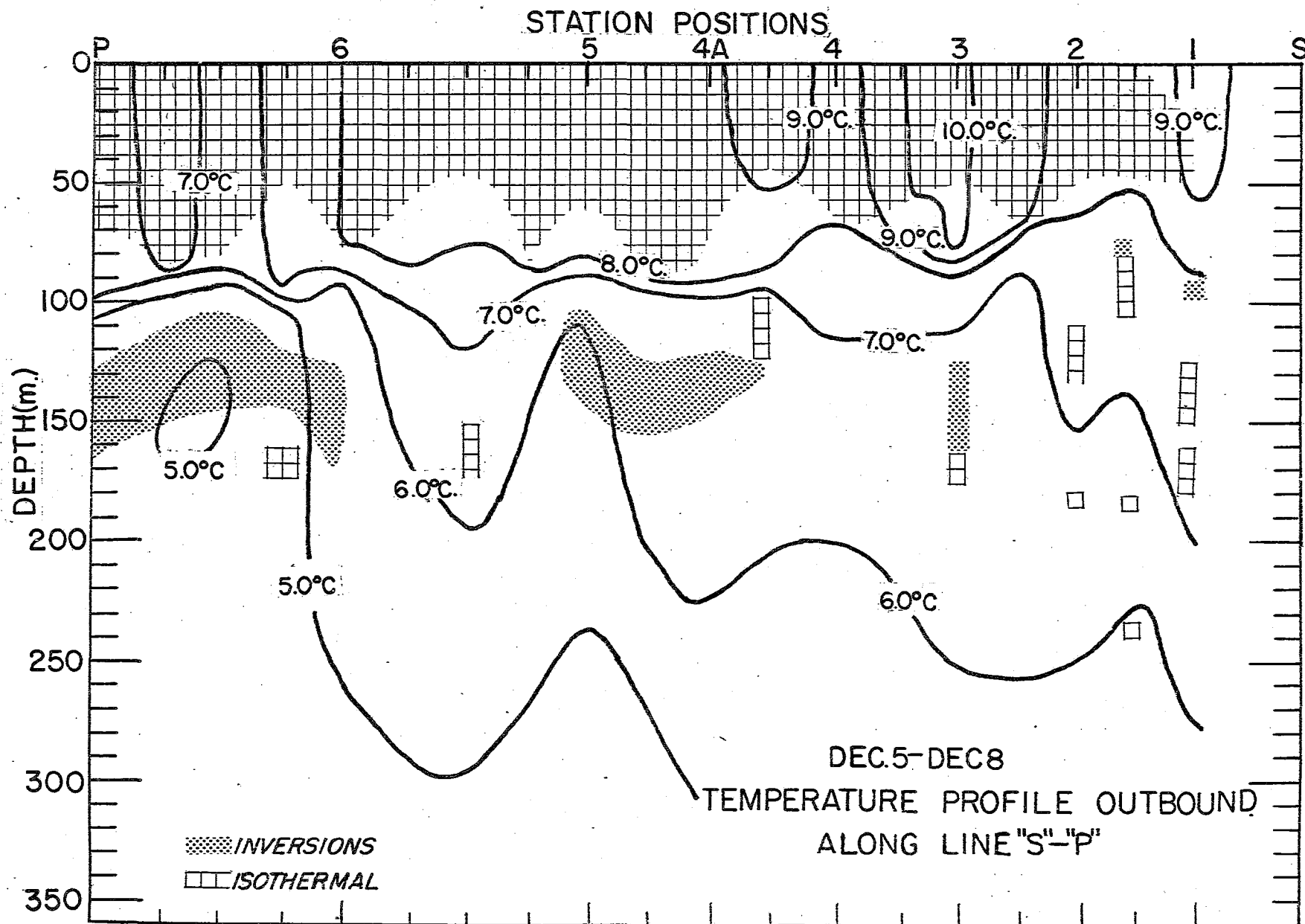

FIGURE 4a.

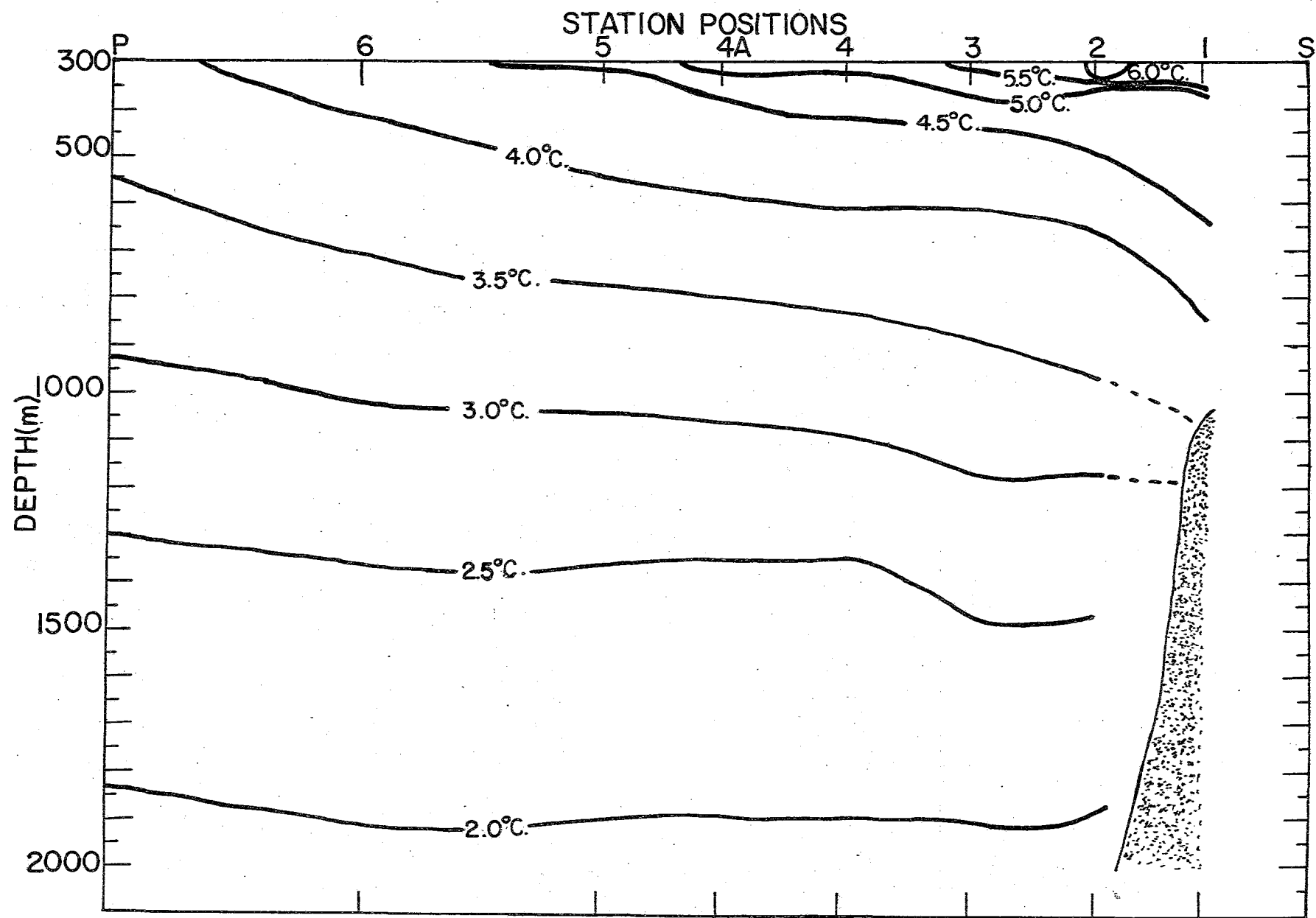

FIGURE 4b.

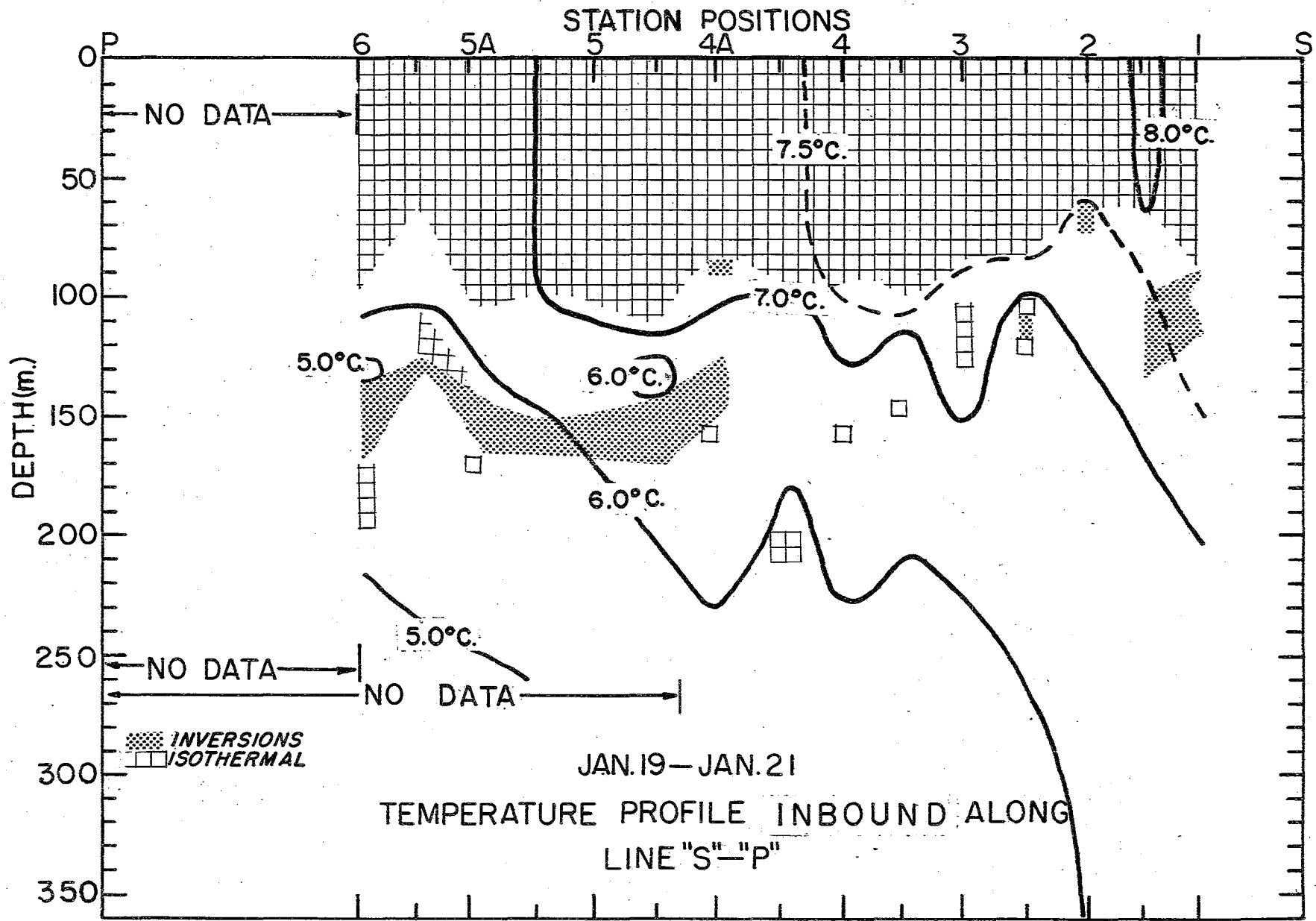

FIGURE 5a

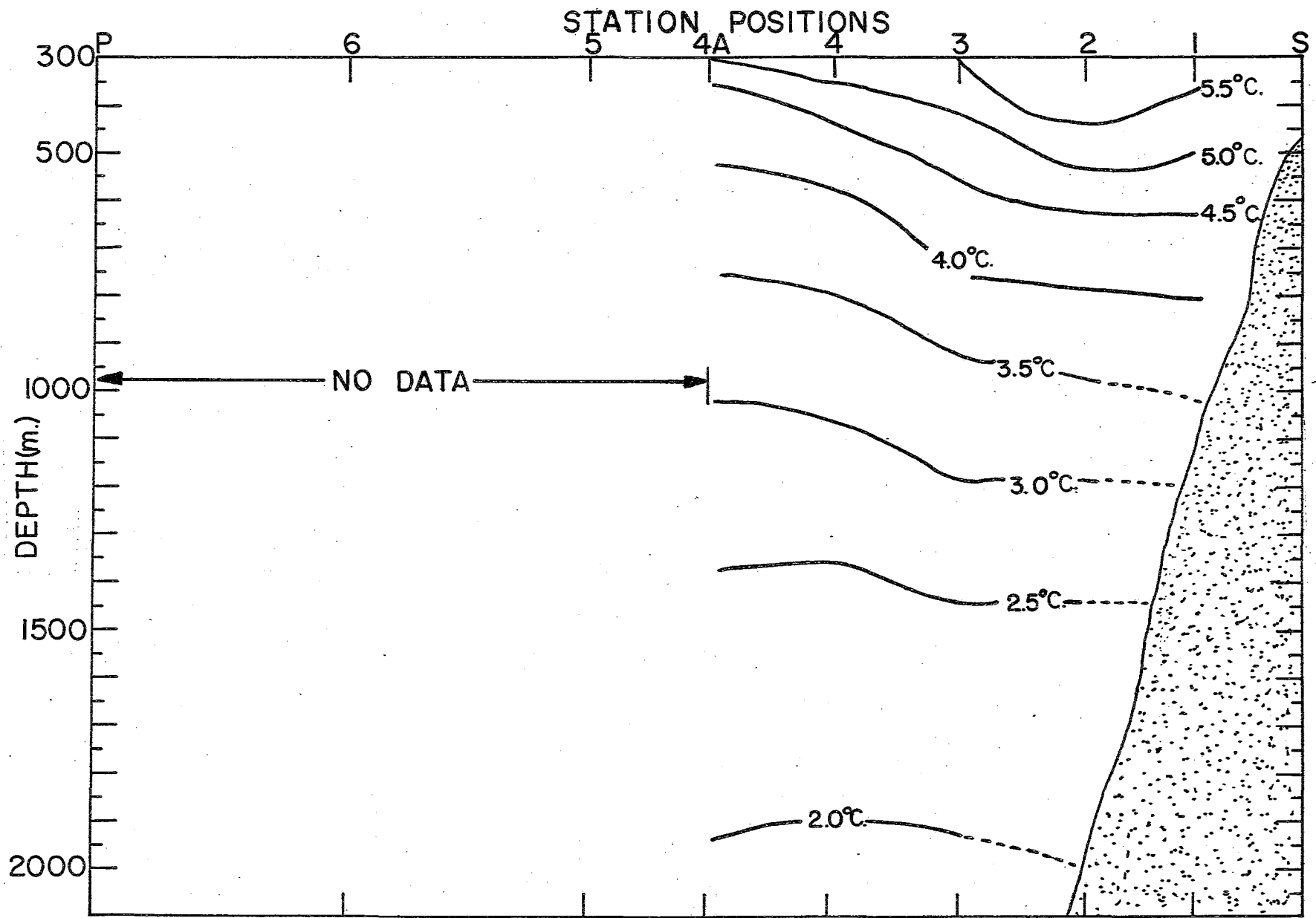

FIGURE 5b

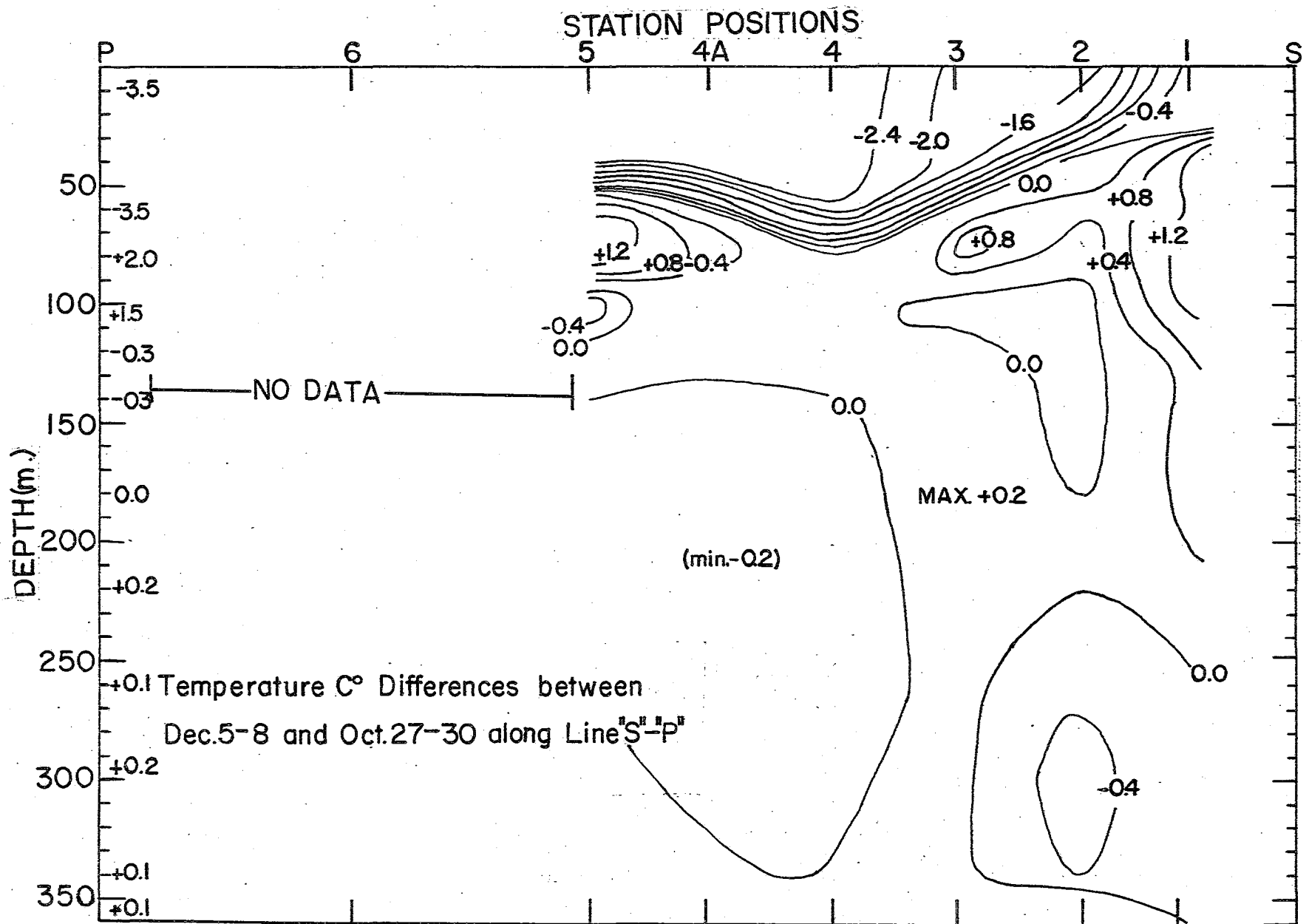

FIGURE 6

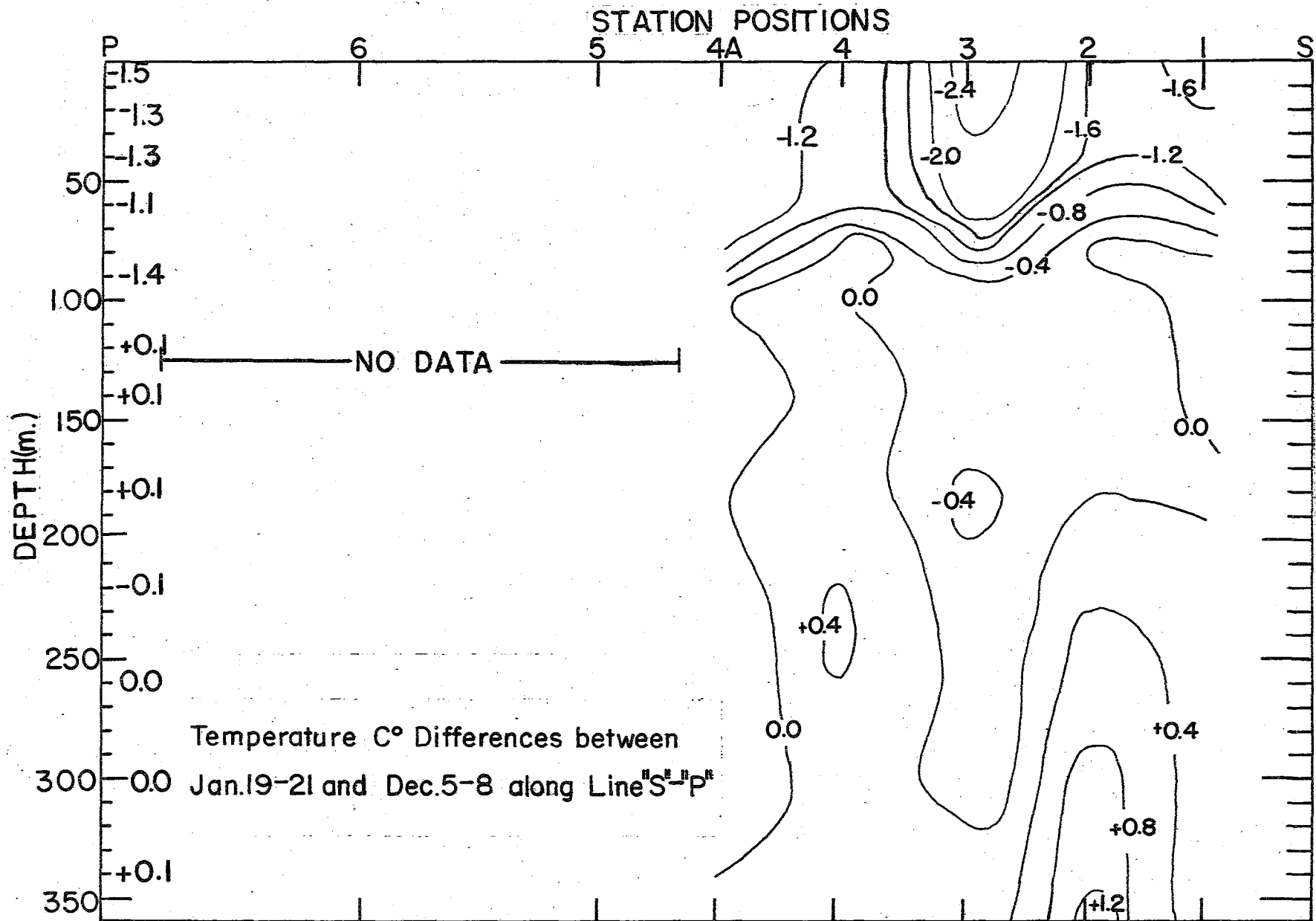

FIGURE 7

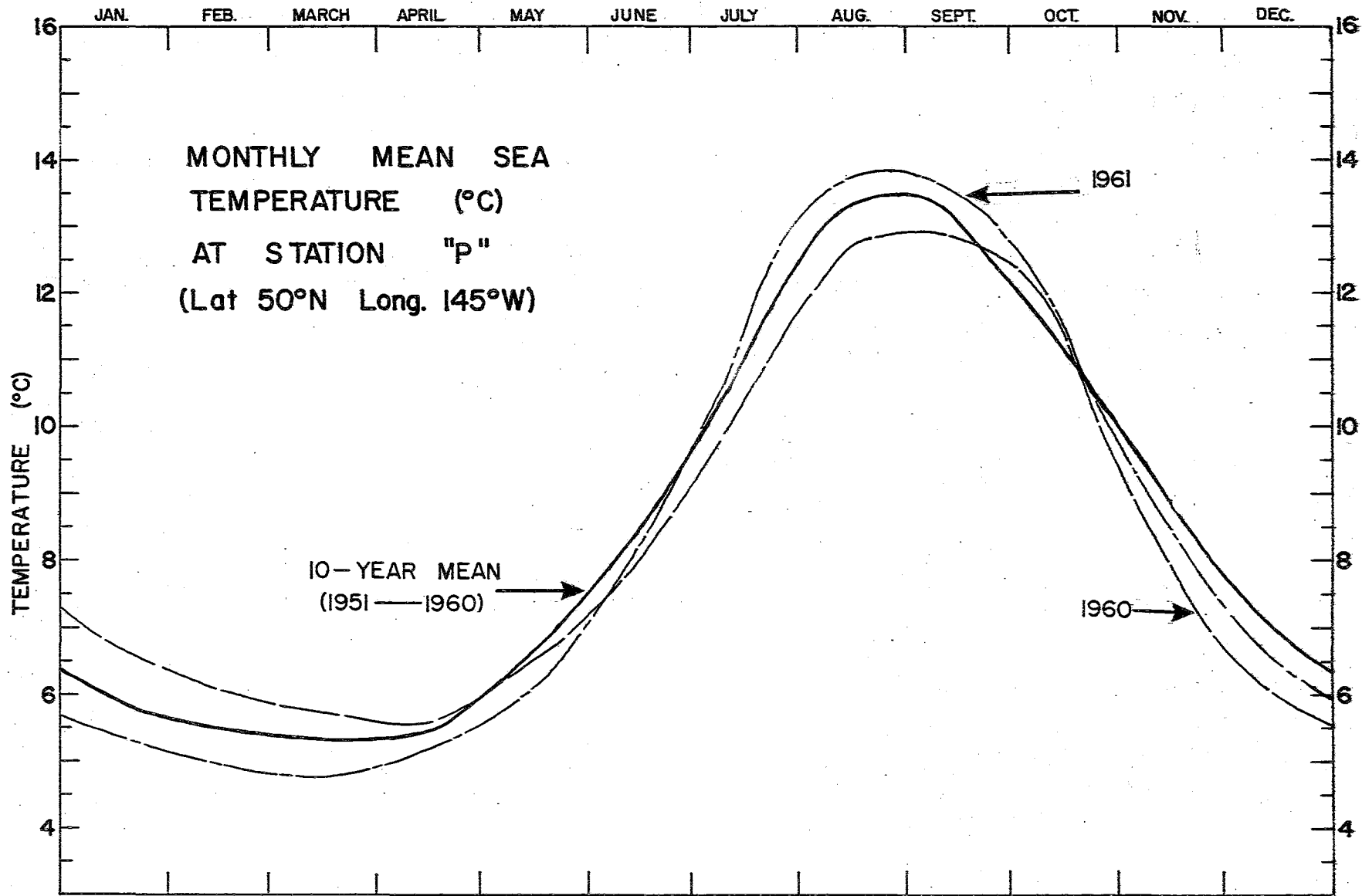

FIGURE 8

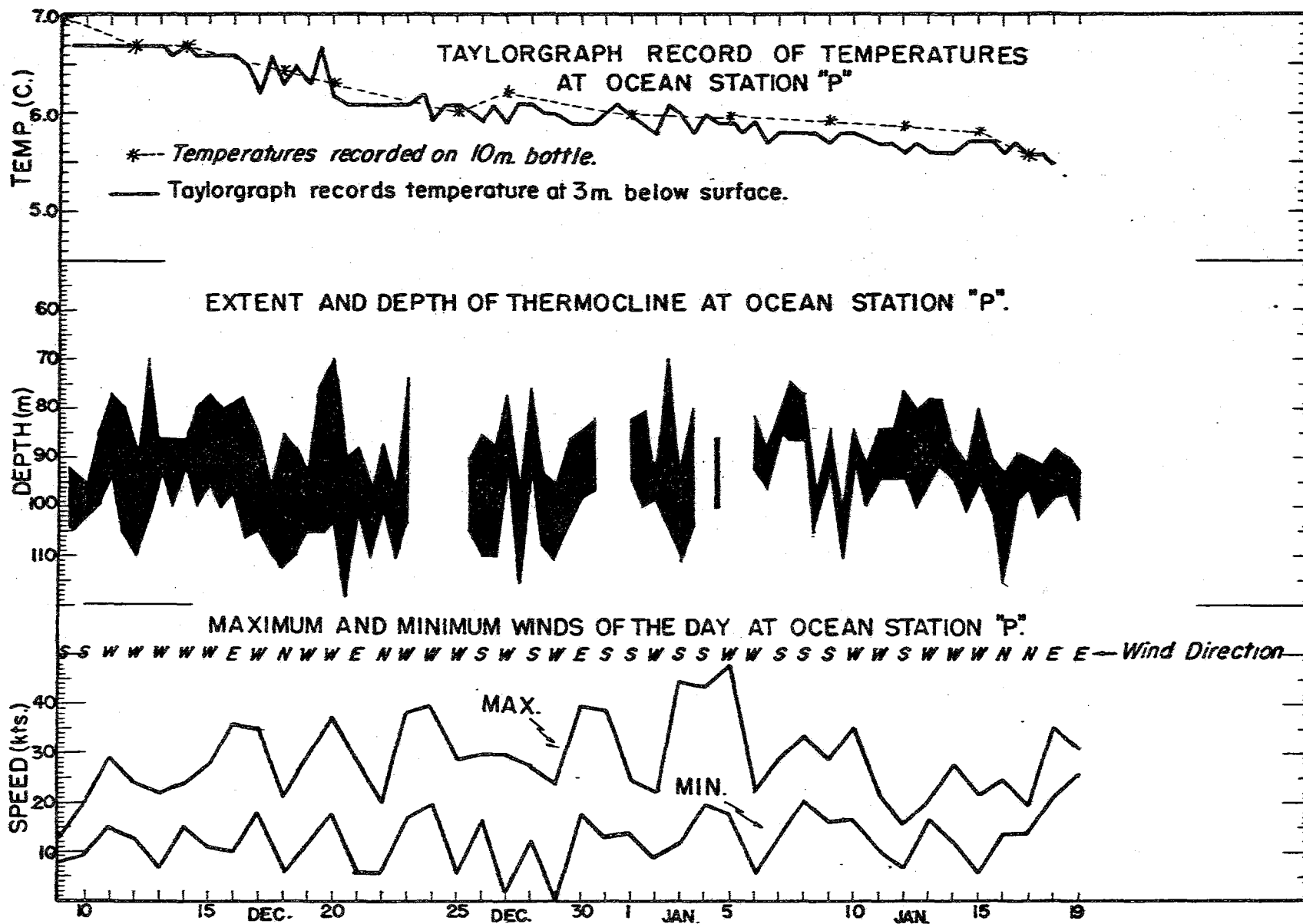

FIGURE 9

*Dr. Neidler*

FISHERIES RESEARCH BOARD OF CANADA  
Pacific Oceanographic Group  
Nanaimo, B. C.

Circular 1962 - 8  
March 16, 1962.

Oceanographic survey of the Northeast Pacific Ocean  
April 16 - May 6, 1962.

An oceanographic survey of the Northeast Pacific Ocean is scheduled for the period April 16 to May 6, 1962. One ship, C.N.A.V. "Oshawa", will occupy four oceanic stations and conduct coastal surveys over the continental shelf between San Francisco and Victoria. The approximate position and length of time on station is shown in Table I.

The principal purpose of this survey is to investigate the transition zone generally known as the Sub-polar Front with respect to its biological and chemical characteristics. There is some evidence that at Station "P" (50° N, 145° W) "blobs" and "tongues" of warmer water tend to intrude. In order to recognize the "patchiness" biologically and chemically it has been found necessary that we should study the biological and chemical characteristics of water situated at a considerable distance south and west of Station "P".

Program of observations

1. Oceanic stations - At each station a routine hydrographic bottle cast to 300 m will be made for temperature and salinity profiles. Phytoplankton pigments and settled samples also will be collected to an approximate depth of 200 m. Several deep casts to 3000 m and at two stations to 4000 m will be made to collect samples for the analyses of particulate and soluble organic material. Larger samples of particulate organic material will be collected from ca. 500 m for the purpose of more detailed analysis. Light measurements, inorganic nutrients and other determinations will be made at these stations, weather and time permitting.
2. Coastal stations - The coastal stations shown in Table I are subject to considerable alteration with respect to position and number. The purpose of this portion of the cruise is to examine the 'land mass' effect, especially with respect to phytoplankton pigments. Other analyses will be performed if time permits.

T.R. Parsons.

*Curran*

Table I

Ocean stations

	<u>Position</u>	<u>Approximate time on station</u>
1.	47° 00' N 133° 00' W	24 hrs.
2.	43° 00' N 141° 00' W	12 hrs.
3.	41° 00' N 143° 00' W	12 hrs.
4.	38° 00' N 145° 00' W	24 hrs.

Coastal stations

1.	40° 20' N, 100 miles due west from the coast, 10 stations at 10 mile intervals	30 min. each
2.	42° 50' N (same as #1)	30 min. each
3.	46° 50' N " "	30 min. each
4.	48° 00' N " "	30 min. each

Schedule

---

Leave Esquimalt	1200 hrs	16 April
Arrive San Francisco		28 April
Leave San Francisco		30 April
Arrive Esquimalt		4-6 May.

Dr. Neall

FISHERIES RESEARCH BOARD OF CANADA  
Pacific Oceanographic Group  
Nanaimo, B. C.

Circular 1962 - 9  
March 30, 1962.

Proposed Oceanographic Survey of the Northeast Pacific Ocean  
May 21 to July 7, 1962

An oceanographic survey of the northeast Pacific Ocean is scheduled for the period May 21 to July 7, 1962. Two ships, C.N.A.V. "Oshawa" and "Whitethroat" will occupy about 220 oceanographic stations (Fig. 1). The positions are listed in Table I.

Program of Observations

1. At each station, serial observations of temperature, salinity and dissolved oxygen will be made. On the Continental Shelf, serial observations will be made to near the bottom. In mid-ocean areas observations will be made to 1200 metres depth except for the special stations designated in Fig. 1 and Table I. At these, observations will be made to a maximum depth of 4000 metres.
2. BT observations will be made at all stations. In addition, each day between 0800 and 1000 hours, a series of 8 BT's (one every 15 min.) will be taken. These will be analyzed and reported each noon to the Meteorological and Oceanographic Information Centre, Esquimalt, B.C.
3. Vertical and horizontal plankton tows will be made once a day.
4. The echo scattering layer will be monitored with an EDO sounder.

Proposed Schedule

<u>C.N.A.V. "Oshawa"</u>		<u>C.N.A.V. "Whitethroat"</u>	
May	25 - Depart Esquimalt, B.C.	May	21 - Depart Esquimalt, B.C.
May	26 - Anchor vicinity of old Swift-sure light (24 hr)	May	30 - Arrive Astoria, Ore.
June	5 - Arrive Kodiak, Alaska	June	1 - Depart Astoria
June	7 - Depart Kodiak	June	17 - Arrive Kodiak, Alaska
June	16 - Arrive Prince Rupert, B.C.	June	19 - Depart Kodiak, Alaska
June	18 - Depart Prince Rupert	July	7 - Arrive Esquimalt.
June	30 - Arrive Esquimalt.		

A.J. Dodimead.

Table I

## Station Positions - C.N.A.V. "Oshawa"

	Station	Latitude	Longitude	Station	Latitude	Longitude
<u>1st Leg</u>	1	48° 32' N	124° 51' W	51	58° 30'	139° 38'
	2	48° 36'	125° 32'	52	58° 18'	140° 00'
	3	48° 37'	126° 00'	53*	57° 54'	140° 45'
	4*	48° 42'	126° 40'	54	57° 30'	141° 30'
	5	48° 46'	127° 40'	55	57° 20'	142° 39'
	6*	48° 50'	128° 40'	56*	57° 10'	143° 50'
	7*	48° 59'	130° 40'	57	57° 00'	145° 00'
	8*	49° 07'	132° 40'	58	56° 00'	145° 00'
	9	49° 15'	134° 40'	59	55° 00'	145° 00'
	10*	49° 25'	136° 40'	60*	55° 23'	143° 44'
	11	49° 32'	138° 40'	61	55° 45'	142° 30'
	12*	49° 40'	140° 40'	62	56° 08'	141° 15'
	13*	49° 44'	142° 40'	63*	56° 30'	140° 00'
	14	49° 00'	142° 50'	64	56° 40'	139° 00'
	15	48° 00'	143° 00'	65	56° 45'	138° 00'
	16	48° 00'	145° 00'	66	56° 50'	137° 00'
	17*	48° 00'	147° 00'	67	56° 55'	136° 30'
	18	49° 00'	147° 00'	68	56° 58'	136° 05'
	19*	50° 00'	147° 00'	69	56° 59'	136° 00'
	20	51° 00'	147° 00'	70	56° 30'	136° 30'
	21	52° 00'	147° 00'	71	56° 00'	137° 00'
	22*	53° 00'	147° 00'	72	55° 15'	139° 00'
	23	54° 00'	147° 00'	73	55° 08'	138° 00'
	24*	55° 00'	147° 00'	74	55° 02'	137° 00'
	25	55° 28'	148° 00'	75	54° 55'	136° 00'
	26	55° 55'	149° 00'	76	54° 49'	135° 00'
	27*	54° 20'	150° 00'	77	54° 45'	134° 00'
	28	56° 50'	150° 40'	78	54° 36'	133° 00'
	29	57° 05'	151° 01'	79	54° 23'	131° 22'
	30	57° 14'	151° 14'	80	54° 12'	131° 16'
	31	57° 26'	151° 30'	81	54° 15'	131° 02'
	32	57° 36'	151° 44'	<u>3rd Leg</u> 82	54° 18'	133° 04'
<u>2nd Leg</u>	33	58° 23'	151° 11'	83	54° 15'	133° 26'
	34	58° 40'	150° 38'	84	54° 12'	133° 47'
	35	59° 00'	150° 00'	85	54° 08'	134° 09'
	36	58° 54'	149° 31'	86	54° 00'	135° 00'
	37	58° 47'	149° 00'	87	54° 00'	137° 00'
	38	58° 35'	148° 00'	88*	54° 00'	139° 00'
	39	58° 23'	147° 00'	89	54° 00'	141° 00'
	40	58° 11'	146° 00'	90	54° 00'	143° 00'
	41	58° 00'	145° 00'	91*	53° 00'	143° 30'
	41A	58° 30'	145° 00'	92	52° 00'	144° 00'
	42*	59° 00'	145° 00'	93	52° 00'	142° 00'
	43	59° 26'	145° 00'	94*	52° 00'	140° 00'
	44	59° 33'	145° 00'	95	52° 00'	138° 00'
	45	59° 24'	143° 28'	96*	52° 00'	136° 00'
	46	59° 18'	142° 30'	97	52° 00'	134° 00'
	47	59° 10'	141° 15'	98	52° 00'	132° 00'
	48	59° 03'	140° 00'	99	52° 00'	131° 30'
	49	58° 56'	138° 50'	100	52° 00'	131° 12'
	50	58° 43'	139° 13'			

\*Serial observations to a maximum depth of 4000 metres.

Table I (cont'd)

## Station Positions - C.N.A.V. "Whitethroat"

	Station	Latitude	Longitude	Station	Latitude	Longitude
<u>1st Leg</u>	1	48° 20'	125° 00'	53*	52° 00'	152° 00'
	2	48° 10'	125° 30'	54	53° 00'	152° 00'
	3	48° 05'	126° 00'	55	53° 48'	153° 00'
	4	47° 40'	127° 30'	56	54° 32'	154° 00'
	5	47° 18'	129° 00'	57	55° 12'	154° 54'
	6	46° 50'	130° 30'	58	55° 27'	155° 14'
	7*	46° 30'	132° 00'	59	55° 39'	155° 30'
	8	45° 30'	132° 00'	<u>3rd Leg</u> 60	57° 10'	152° 00'
	9	44° 30'	132° 00'	61	56° 30'	152° 00'
	10	43° 30'	132° 00'	62	56° 25'	152° 00'
	11	42° 30'	132° 00'	63	56° 10'	152° 00'
	12*	41° 30'	132° 00'	64	56° 00'	152° 00'
	13	42° 20'	130° 30'	65	56° 00'	152° 00'
	14	43° 00'	129° 30'	66	54° 30'	154° 00'
	15*	43° 30'	128° 30'	67	54° 00'	156° 00'
	16	44° 00'	127° 30'	68	54° 13'	158° 00'
	17	44° 30'	126° 30'	69	54° 30'	160° 00'
	18	45° 05'	125° 30'	70	54° 00'	159° 45'
	19	45° 21'	125° 00'	71*	53° 00'	159° 18'
	20	45° 25'	124° 40'	72	52° 00'	158° 48'
	21	45° 30'	124° 15'	73	51° 00'	158° 20'
<u>2nd Leg</u>	22	45° 30'	124° 40'	74*	50° 00'	157° 52'
	23	46° 25'	125° 00'	75	49° 00'	157° 28'
	24	45° 55'	126° 00'	76	48° 00'	157° 00'
	25*	45° 38'	127° 30'	77*	47° 00'	157° 00'
	26	45° 20'	129° 00'	78	46° 00'	157° 00'
	27	45° 02'	130° 30'	79	45° 00'	157° 00'
	28*	44° 45'	132° 00'	80	44° 00'	157° 00'
	29	44° 28'	133° 30'	81*	43° 00'	157° 00'
	30	44° 10'	135° 00'	82	42° 00'	157° 00'
	31	44° 08'	136° 30'	83	42° 38'	155° 00'
	32	44° 03'	138° 00'	84*	43° 16'	153° 00'
	33	44° 00'	140° 00'	85	43° 53'	151° 00'
	34*	43° 00'	140° 41'	86	44° 31'	149° 00'
	35	42° 00'	141° 18'	87	45° 00'	147° 30'
	36	41° 00'	141° 50'	88*	45° 20'	146° 00'
	37	40° 00'	142° 25'	89	45° 38'	144° 30'
	38*	39° 00'	143° 00'	90*	45° 58'	143° 00'
	39	39° 30'	145° 10'	91	46° 15'	141° 30'
	40	40° 00'	147° 30'	92	46° 30'	140° 00'
	41	41° 00'	147° 30'	93*	46° 30'	138° 00'
	42*	42° 00'	147° 30'	94	46° 30'	136° 00'
	43	43° 00'	147° 30'	95	46° 30'	134° 00'
	44	44° 00'	147° 30'	96*	46° 30'	132° 00'
	45	45° 00'	147° 30'	97	46° 50'	130° 30'
	46	46° 00'	147° 30'	98	47° 18'	129° 00'
	47	46° 40'	149° 00'	99	47° 40'	127° 30'
	48	47° 20'	150° 30'	100	48° 05'	126° 00'
	49*	48° 00'	152° 00'	101	48° 10'	125° 30'
	50	49° 00'	152° 00'	102	48° 20'	125° 00'
	51	50° 00'	152° 00'			
	52	51° 00'	152° 00'			

\*Serial observations to a maximum depth of 4000 metres.

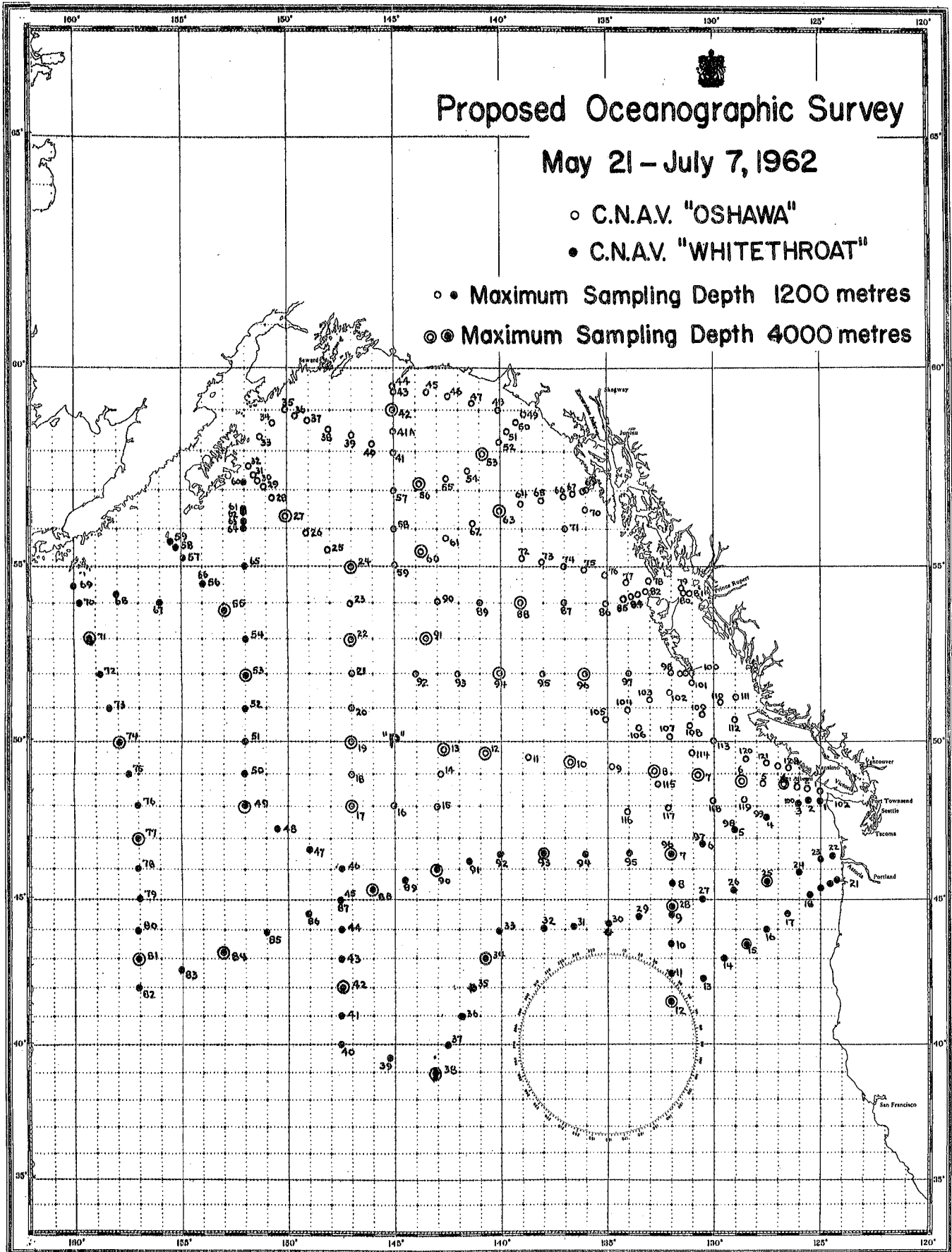

# Proposed Oceanographic Survey

May 21 – July 7, 1962

○ C.N.A.V. "OSHAWA"

● C.N.A.V. "WHITETHROAT"

○ • Maximum Sampling Depth 1200 metres

◎ • Maximum Sampling Depth 4000 metres

FIGURE I

*D. Needler*

FISHERIES RESEARCH BOARD OF CANADA  
Pacific Oceanographic Group  
Nanaimo, B. C.

Circular 1962 - 10  
March 30, 1962.

Sea temperatures observed between "Swiftsure" and  
Ocean Station "P", 28 February - 5 March 1962.

This report is based on the data radioed in on the 16th March, 1962 from John Meikle who is aboard the C.M.S. "St. Catharines". The data were concerned only with temperatures observed from the surface to 300 metres depth along line "S" - "P".

Figure 1 describes the geographical positions of oceanographic stations between "Swiftsure" and Ocean Station "P".

Figure 2 illustrates the temperature distribution along the line "S"- "P", from the surface to 300 metres depth. The warmest water encountered was in the surface isothermal layer at the coastal end of the line (Station 1, 8.4° C). The coldest surface waters were at Station "P" (5.9° C). The temperature distribution conveniently separates line "S"- "P" into three distinct regions. A warm water region occurred at the coastal end (between Stations 1 and 2). In this region, the horizontal gradient showed a marked temperature decrease to Station 2. In the mid-section of the line (Stations 2-5), the temperatures at each level were nearly constant. At the seaward end of the line, there was at all levels another marked decrease of temperature from Stations 5 to "P". In this way, the seaward end of the line was identified as a cold water region.

Figure 3 describes the differences between temperatures observed six weeks previously (19-22 Jan. 1962) and these last observations (28 Feb. - 5 Mar. 1962). Positive values indicate warmer temperatures in the latter period. In this figure, four features are brought to our attention. These were the temperature increases evident at Station 1 and at "P", and the temperature decreases observed at Station 2 and in the region seaward of Station 3.

The changes in temperature evident at Station 1 and 2 appear to have had a six-week cycle dating back to autumn last year (Oct 27-30, 1961). Whenever warming was observed at Station 1, cooling was evident at Station 2 and vice-versa. These temperature differences at Station 1 occurred in the near-surface waters; whereas, the associated temperature differences at Station 2 occurred below 200 metres depth.

The temperature decreases observed between Stations 3 and 4A are attributable to seasonal cooling of the surface isothermal layer. There were no evident temperature changes in this zone below the thermocline.

At Station "P", temperature increases were observed from the surface to a depth of about 250 metres. Normally, seasonal cooling occurs at this time. Thus, the warming of the near surface waters can only be attributed to a

northward transport of warmer waters. During the six weeks previous to the arrival of the C.M.S. "St. Catharines", the continuous temperature record (C.M.S. "Stonetown") of Station "P" water at the 3 metres depth did show a 1/2 C° increase. The speculation made in Circular 1962 - 7 (March 12, 1962), that there is possibly a two-year cycle of advance and retreat of warm (southern) waters, may be borne out, if the warm water intrusion persists.

A further and more extensive report regarding the findings from the entire cruise will be made sometime after its return on 16 April 1962.

W. Atkinson.

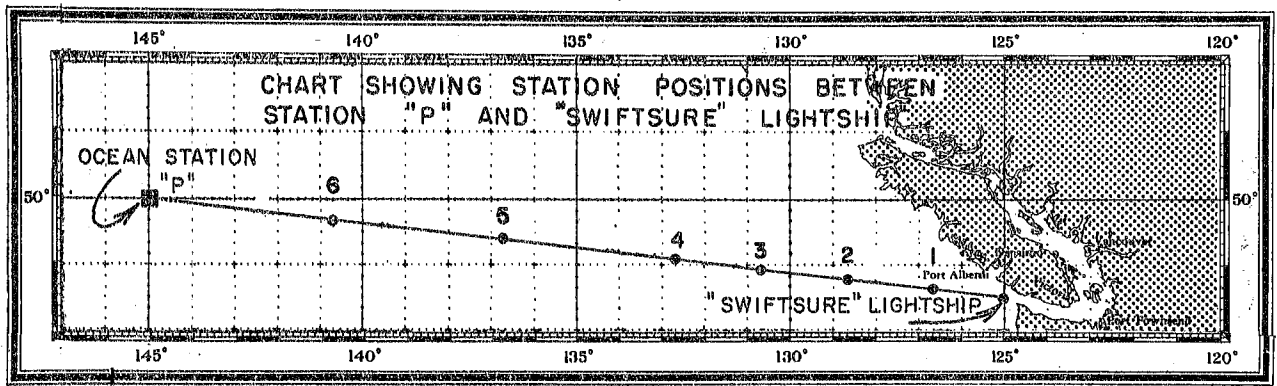

Figure 1.

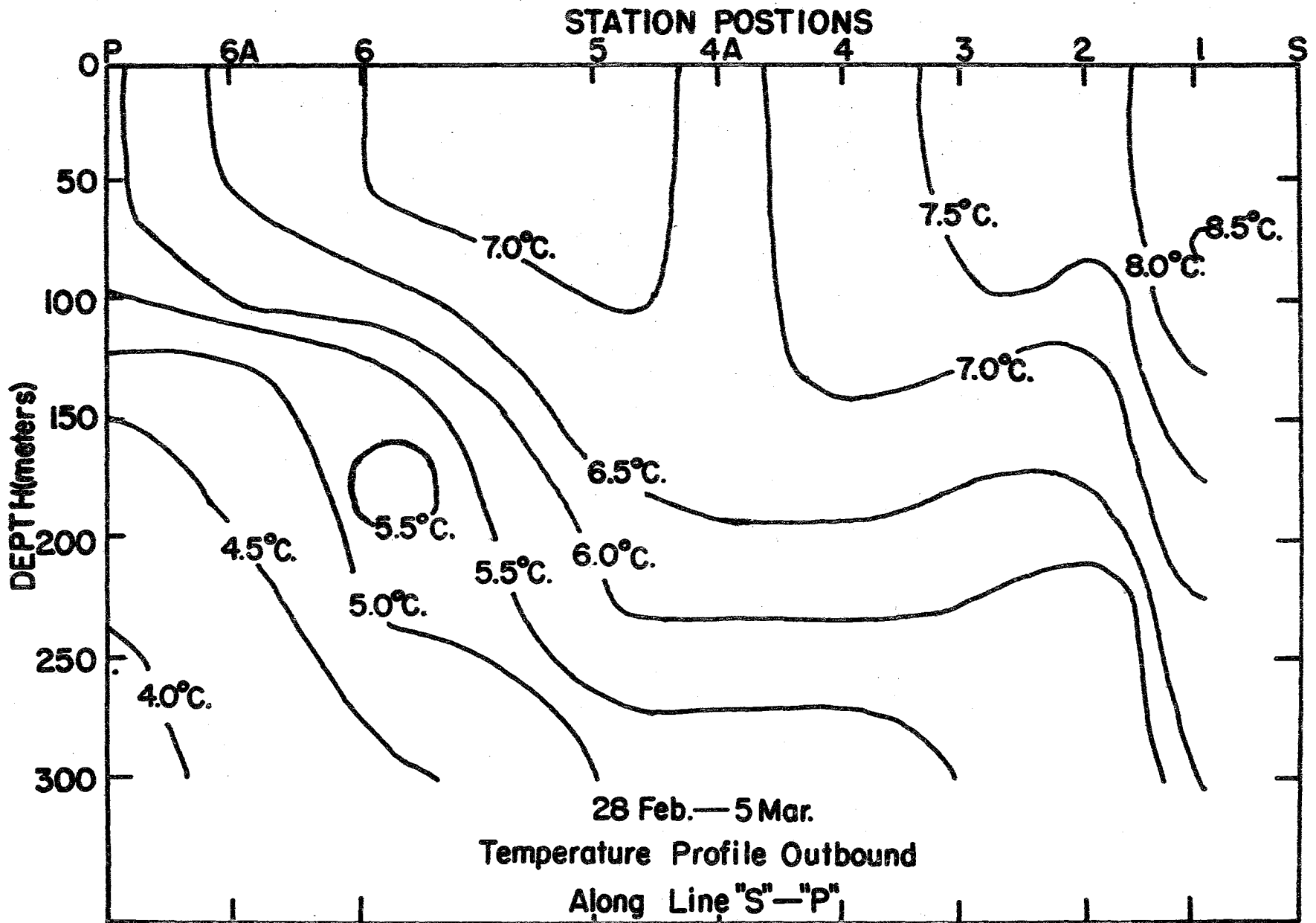

Figure 2

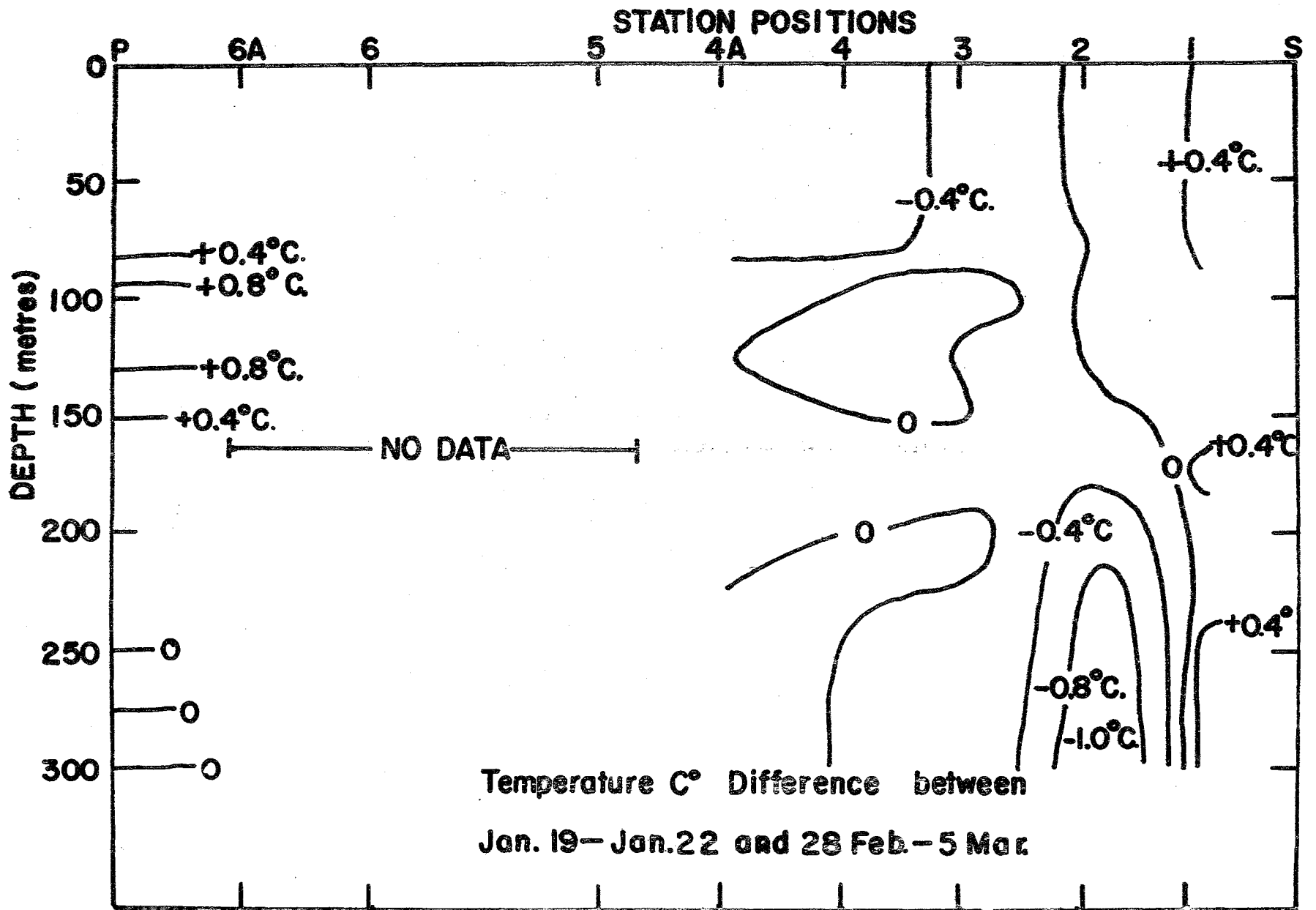

Figure 3

D. Neider

FISHERIES RESEARCH BOARD OF CANADA  
Pacific Oceanographic Group  
Nanaimo, B. C.

Circular 1962 - 11  
April 24, 1962.

Transport calculations for the North Pacific Ocean  
January, February 1962

Sverdrup (1947), Stommel (1948), and Munk (1950) have shown that the total steady-state transport of mass in the ocean depends primarily on the curl of the wind stress components acting on the surface of the ocean. Calculations have been performed to estimate the wind stress over the surface of the ocean by computing mean geostrophic winds from pressure differences between grid points, applying a transformation to estimate surface winds and using a "square law" formula to relate wind speeds to surface stresses (Fofonoff, MS 1960, 1961). The purpose of these calculations is two-fold. First, to find out how long an averaging period is necessary to approach steady-state conditions and second, to gain some idea of the variability, both with latitude and time, of the transport that is imposed on the ocean by the atmosphere.

Detailed descriptions of the method used for evaluating the transports are given in the introduction to the annual volumes of transport computations (Fofonoff, MS 1960, 1961). The actual computer program for the calculation of mass transport is contained in the program manual M-1 (Fofonoff and Froese, MS 1960).

Six grid points in regions of special interest have been selected to evaluate the transport components for a given month in terms of mean values. They lie in the Gulf of Alaska (55° N, 155° W), Ocean Station "P" (average values at 50° N, 150° W and 50° N, 140° W), west of California Current (35° N, 135° W), adjacent to the Kuroshio Current (30° N, 160° E), the Oyashio Current (45° N, 155° E), and the Kamchatka Current (50° N, 160° E).

At each grid point the mean values and the standard deviations of the transport components from values for the same month from previous years are given in tabular form. In addition, the mean values of the integrated total and geostrophic transport for the month and eleven preceding months are given and compared with similar averages in previous years to indicate the long term trend of computed transport.

The departures of the monthly values from their means have been divided into three classes in terms of the number of standard deviations from the mean. The classes are:

Class 1: departure of less than one standard deviation from the mean (68% of values for a Gaussian distribution). Values falling in this range are termed "normal".

Class 2: departures of one to two standard deviations from the mean (17% of values for a Gaussian distribution). These values will be referred to as "abnormal".

Class 3: departures greater than two standard deviations from the mean (5% of values for a Gaussian distribution). Values whose variation falls in this range will be denoted as "extreme".

Transport charts

- I. Monthly mean sea-level atmospheric pressure given as the anomaly of mean atmospheric pressure from 1000 mbs. in units of 1/10 millibars.
- II. Meridional component of Ekman transport ( $V_E$ ) in units of 10 metric tons/km/sec.
- III. Zonal component of Ekman transport ( $U_E$ ) in units of 10 metric tons/km/sec.
- IV. Meridional component of total transport ( $V$ ) in units of 100 metric tons/km/sec.

The values shown on chart IV are  $-V$ .

- V. Integrated total transport ( $\Psi$ ) in units of 100,000 metric tons/sec.
- VI. Integrated geostrophic transport ( $\Psi_g$ ) in units of 100,000 metric tons/sec.

The convention of signs adopted is that northward and eastward transport shall be considered as positive and southward and westward flow shall be negative.

References

Fofonoff, N.P. MS, 1960. Transport computations for the North Pacific Ocean 1955-58. Fish. Res. Bd. Canada, MS Rept., Oceanogr. and Limnol. Series, Nos. 77-80, 93 pp.

MS, 1961. Transport computations for the North Pacific Ocean 1959. Fish. Res. Bd. Canada, MS Rept., Oceanogr. and Limnol. Series, No. 85, 181 pp.

Fofonoff, N.P., and C. Froese. MS, 1960. Programs for oceanographic computations and data processing on the electronic digital computer ALWAC III-E. M-1 miscellaneous programs. Fish. Res. Bd. Canada, MS Rept., Oceanogr. and Limnol. Series, No. 72, 35 pp.

Munk, W.H. 1950. On the wind-driven ocean circulation. J. Meteorol. L (2), 79-93.

Stommel, H. 1948. The westward intensification of wind-driven ocean currents. Trans. Amer. Geophys. Union 29, (2): 202-206.

Sverdrup, H.V. 1947. Wind-driven currents in a baroclinic ocean; with applications to the equatorial currents of the Eastern Pacific. Proc. Nat. Acad. Sc., 33 (11): 318-326.

Assessment of transport calculations for January, 1962

Generally the atmospheric pressure was higher over the North Pacific in January 1962 than it has been in January for the past seven years. An almost normal pressure pattern was formed consisting of a strong "high" over China and Russia, another weaker "high" at the coast of the United States and a "low" between the two. Usually the centre of the "low" is near the Aleutian Islands. However in January 1962, the "low" was shifted west and south to a position between Japan and the Kamchatka Peninsula. In this month the pressure anomaly (from 1000 millibars) in the "low" was positive whereas it is normally negative.

This pressure distribution left the transport components on the eastern side of the North Pacific "normal" except for the meridional component of Ekman transport in the California Current which was slightly "abnormal".

However on the west coast the transport components showed more deviation from the mean. The components of Ekman transport were "extreme" for the Kuroshio Current and "abnormal" for the Oyashio Current. The meridional component was "abnormal" for the Kamchatka Current.

The meridional component of total transport was "abnormal" for both the Kamchatka and Kuroshio Currents.

The integrated total and geostrophic components were "abnormal" for the Kamchatka and Oyashio Currents. The trends of integrated transport were "normal" except for the Kamchatka Current which was "abnormal".

Assessment of transport calculations for February, 1962

The atmospheric pressure pattern over the North Pacific Ocean in February 1962 was not markedly unusual. There was a "low" area at the western end of the Aleutian Islands and a "high" over China. Normally, a "high" forms off the U.S. coast. However, in February 1962, it did not develop to its normal value. Coupled with a<sup>++</sup>weak "high" the "low" over the Aleutians had lower pressures than usual. It was this pattern that gave rise to the transports calculated.

The Kamchatka Current and the Gulf of Alaska showed the meridional component of total transport and the trends of integrated transport "abnormal" with the remaining components remaining "normal".

The Oyashio and Kuroshio Currents were similar in that both had "normal" components of integrated and trends of integrated transport with "abnormal" total transport and "extreme" zonal component of Ekman transport. However, the meridional component of Ekman transport was "normal" for the Oyashio and "abnormal" for the Kuroshio.

Ocean Station "P" was normal for all components studied except the Ekman transport which was "abnormal".

The California Current had "abnormal" trends of integrated transport and integrated total transport. Otherwise the components were "normal".

Table 1. A comparison of transport components at selected grid points with average values for the same month from previous years.

1. Kamchatka Current (50° N, 160° E)						4. Gulf of Alaska (55° N, 155° W)							
	Jan 1962	Jan 1961	Jan Mean (55-60)	$\sigma$	$\frac{ x-\bar{x} }{\sigma}$	Class		Jan 1962	Jan 1961	Jan Mean (55-60)	$\sigma$	$\frac{ x-\bar{x} }{\sigma}$	Class
$V_E$	5	-46	-20.2	16.8	1.50	2	$V_E$	17	79	12.7	15.7	0.27	1
$U_E$	2	-63	-33.8	40.0	0.89	1	$U_E$	-17	27	-3.8	79.5	0.17	1
$-V$	-15	-144	-125.2	64.5	1.71	2	$-V$	-120	-129	-55.8	89.8	0.72	1
$\Psi$	49	550	402.2	336.7	1.05	2	$\Psi$	169	209	239.0	209.0	0.33	1
$\Psi_0$	44	547	410.7	352.0	1.04	2	$\Psi_0$	166	197	233.7	203.4	0.33	1
$\overline{\Psi}$	161.1	278.6	215.8	51.8	1.06	2	$\overline{\Psi}$	92.1	100.3	122.0	43.0	0.70	1
$\overline{\Psi}_0$	172.6	291.3	230.2	48.8	1.18	2	$\overline{\Psi}_0$	92.9	99.4	122.0	42.6	0.68	1
2. Oyashio Current (45° N, 155° E)						5. Ocean Station "P" (50° N, 145° W)							
$V_E$	-3	-95	-53.8	35.3	1.44	2	$V_E$	-3.0	34.5	-22.3	29.2	0.66	1
$U_E$	-3	-67	-35.7	24.7	1.33	2	$U_E$	23.5	86.0	33.3	53.5	0.17	1
$-V$	-32	3	-50.0	49.0	0.37	1	$-V$	-28.0	-135.5	-52.5	90.2	0.27	1
$\Psi$	11	822	371.7	317.3	1.14	2	$\Psi$	41.0	138.5	89.9	96.6	0.50	1
$\Psi_0$	7	869	412.2	334.1	1.21	2	$\Psi_0$	41.5	134.5	90.7	95.1	0.52	1
$\overline{\Psi}$	-4.8	65.7	52.5	87.6	0.66	1	$\overline{\Psi}$	35.2	54.0	31.6	10.9	0.33	1
$\overline{\Psi}_0$	21.0	95.8	81.6	89.4	0.68	1	$\overline{\Psi}_0$	38.3	60.5	34.6	10.4	0.36	1
3. Kuroshio Current (30° N, 140° E)						6. California Current (35° N, 135° W)							
$V_E$	-42	-12	-18.3	9.3	2.56	3	$V_E$	2	-74	-51.2	51.5	1.03	2
$U_E$	-44	-37	-21.5	9.2	2.45	3	$U_E$	8	123	36.5	56.5	0.50	1
$-V$	-18	9	7.2	17.6	1.43	2	$-V$	48	61	15.8	65.1	0.49	1
$\Psi$	-152	-581	-365.8	305.4	0.70	1	$\Psi$	-17	-35	-28.0	29.8	0.37	1
$\Psi_0$	-122	-510	-339.7	274.6	0.79	1	$\Psi_0$	-18	-32	-25.2	27.5	0.26	1
$\overline{\Psi}$	-307.3	-286.5	-304.8	22.0	0.11	1	$\overline{\Psi}$	-36.3	-29.9	-34.6	5.8	0.29	1
$\overline{\Psi}_0$	-311.6	-289.2	-311.2	23.8	0.02	1	$\overline{\Psi}_0$	-34.6	-28.6	-32.8	5.9	0.31	1

Explanation of table on page 5.

Table 2. A comparison of transport components at selected grid points with average values for the same month from previous years.

1. Kamchatka Current (50° N, 160° E)

	Feb 1962	Feb 1961	Feb Mean (55-60)	$\sigma$	$\frac{ x-\bar{x} }{\sigma}$	Class
$V_E$	-25	8	-12.2	17.7	0.72	1
$U_E$	-41	-11	-31.0	23.9	0.42	1
$-V$	-20	-51	-66.7	34.5	1.35	2
$\psi$	167	357	196.2	172.9	0.17	1
$\psi_g$	166	365	203.8	171.6	0.22	1
$\bar{\psi}_g$	145.3	278.7	222.6	56.7	1.36	2
$\bar{\psi}_g$	156.0	309.0	236.6	53.6	1.50	2

4. Gulf of Alaska (55° N, 155° W)

	Feb 1962	Feb 1961	Feb Mean (55-60)	$\sigma$	$\frac{ x-\bar{x} }{\sigma}$	Class
$V_E$	17	0	0.7	21.8	0.75	1
$U_E$	13	-15	0.5	17.3	0.72	1
$-V$	4	-104	-46.2	41.4	1.21	2
$\psi$	25	165	194.0	181.1	0.93	1
$\psi_g$	22	164	191.8	174.7	0.97	1
$\bar{\psi}_g$	80.4	106.1	120.4	31.5	1.27	2
$\bar{\psi}_g$	81.1	105.3	120.6	31.2	1.27	2

2. Oyashio Current (45° N, 155° E)

	Feb 1962	Feb 1961	Feb Mean (55-60)	$\sigma$	$\frac{ x-\bar{x} }{\sigma}$	Class
$V_E$	-40	-23	-36.8	29.8	0.11	1
$U_E$	-52	-33	-2.5	15.8	3.13	3
$-V$	-49	-105	-23.8	18.6	1.35	2
$\psi$	154	343	177.7	145.3	0.16	1
$\psi_g$	163	379	200.8	144.9	0.26	1
$\bar{\psi}_g$	-20.6	71.5	56.0	98.1	0.78	1
$\bar{\psi}_g$	3.0	101.5	85.6	100.3	0.82	1

5. Ocean Station "P" (50° N, 145° W)

	Feb 1962	Feb 1961	Feb Mean (55-60)	$\sigma$	$\frac{ x-\bar{x} }{\sigma}$	Class
$V_E$	4.5	-50	-29.5	31.3	1.09	2
$U_E$	4.5	37	17.8	9.2	1.45	2
$-V$	-2.0	-137.0	3.2	72.5	0.07	1
$\psi$	37.5	160.0	34.2	95.9	0.03	1
$\psi_g$	36.5	164.5	36.0	93.3	0.01	1
$\bar{\psi}_g$	25.0	63.7	33.2	20.7	0.40	1
$\bar{\psi}_g$	27.7	70.5	36.0	20.4	0.41	1

3. Kuroshio Current (30° N, 140° E)

	Feb 1962	Feb 1961	Feb Mean (55-60)	$\sigma$	$\frac{ x-\bar{x} }{\sigma}$	Class
$V_E$	-25	-25	-7.7	9.6	1.81	2
$U_E$	-25	-28	-8.2	7.5	2.24	3
$-V$	23	7	5.7	15.9	1.09	2
$\psi$	-267	-558	-366.7	168.2	0.59	1
$\psi_g$	-217	-499	-351.0	149.7	0.90	1
$\bar{\psi}_g$	-283.1	-305.0	-304.1	38.2	0.55	1
$\bar{\psi}_g$	-288.1	-304.4	-309.8	33.2	0.65	1

6. California Current (35° N, 135° W)

	Feb 1962	Feb 1961	Feb Mean (55-60)	$\sigma$	$\frac{ x-\bar{x} }{\sigma}$	Class
$V_E$	-17	-51	-35.5	67.0	0.28	1
$U_E$	8	25	26.5	57.4	0.32	1
$-V$	-1	118	19.0	51.5	0.39	1
$\psi$	1	-110	-15.8	15.4	1.09	2
$\psi_g$	3	-106	-13.2	16.6	0.98	1
$\bar{\psi}_g$	-27.0	-35.3	-35.2	5.7	1.44	2
$\bar{\psi}_g$	-25.5	-33.8	-33.2	5.4	1.42	2

Explanation of tables:

$\bar{x}$  is based on (55-60) values.

$\frac{|x-\bar{x}|}{\sigma}$  denotes deviation from mean in terms of standard deviation.

$\psi, \psi_g$  are trends of integrated transports based on the straight mean of the month and the eleven preceding months.

Classes are explained on pages 1-2.

Jan 1 Jan 30 1962

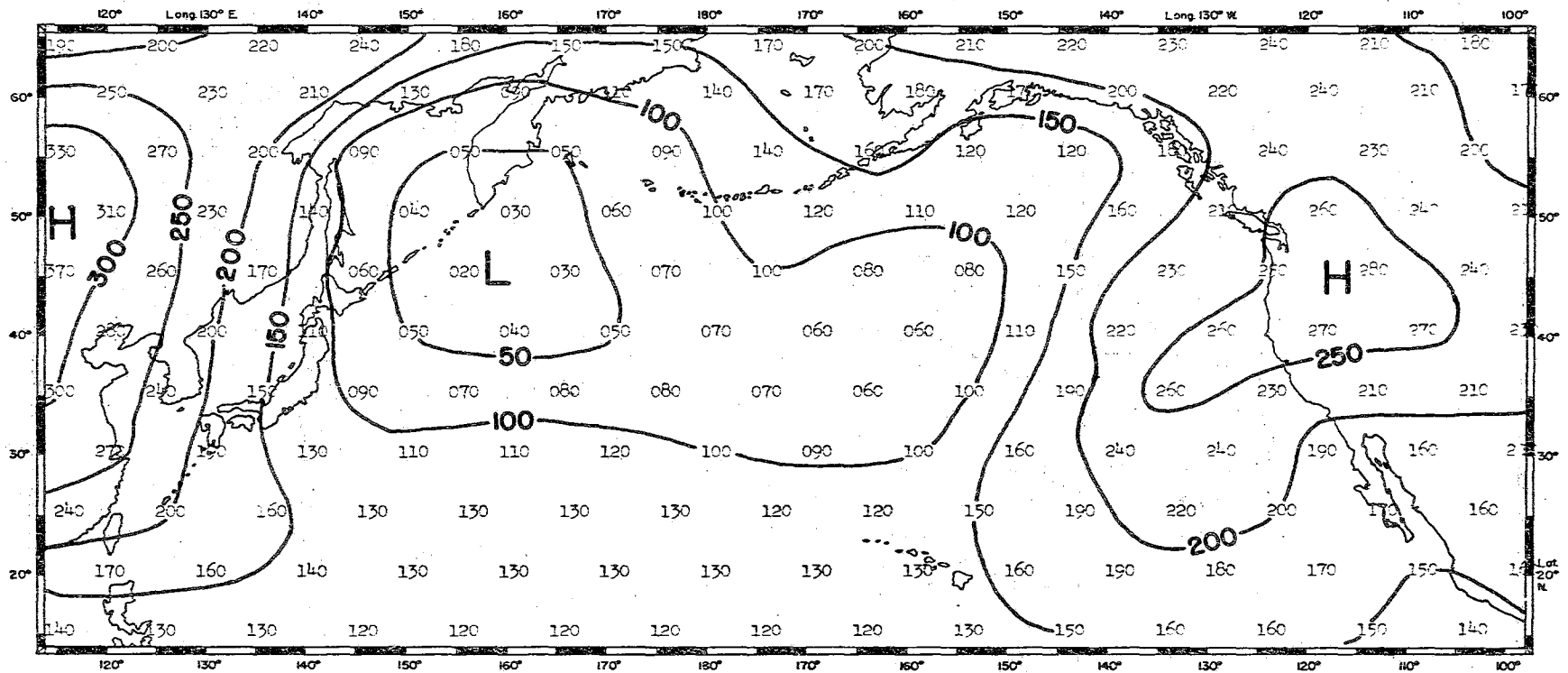

I. Atmospheric Pressure

Jan 1 Jan 30 1962

Jan 1 Jan 30 1962

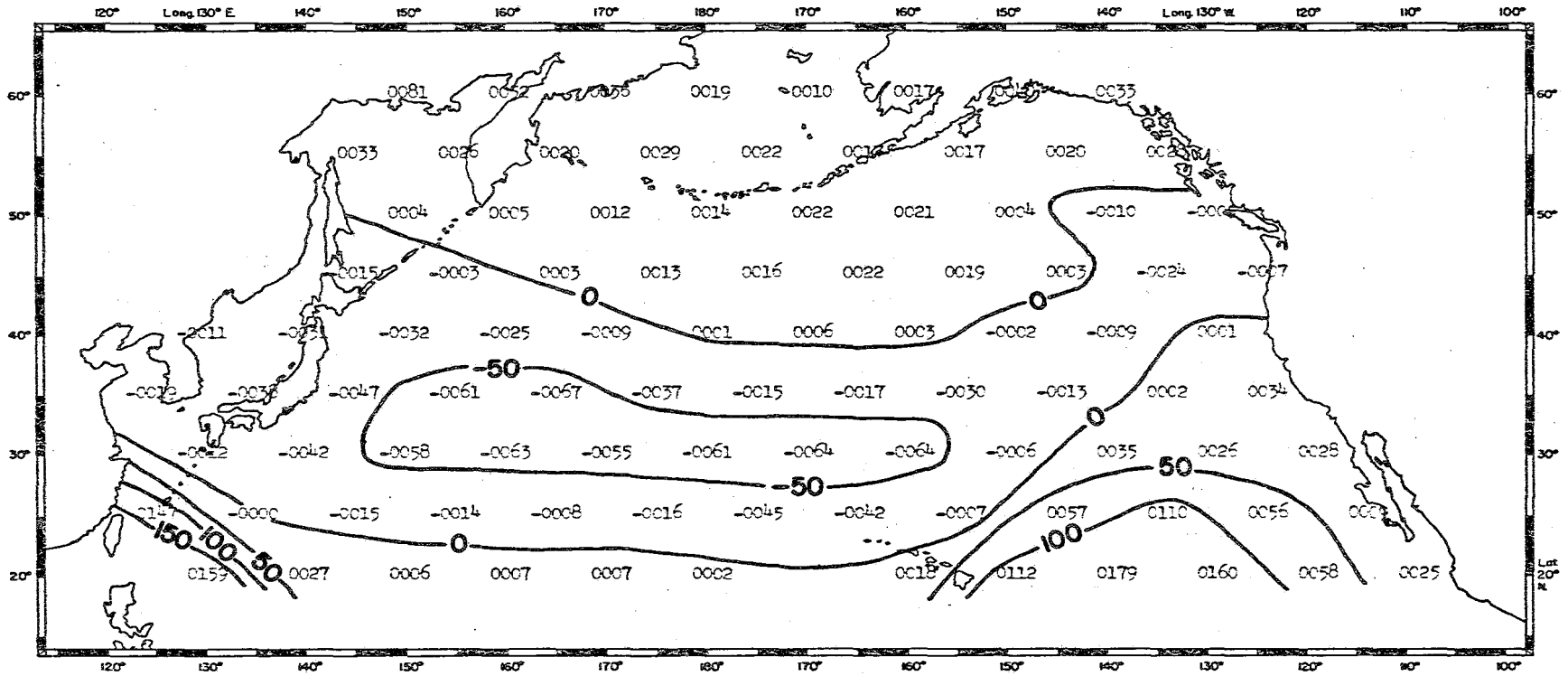

II. Meridional Component of Ekman Transport

Jan 1 Jan 30 1962

Jan 1 Jan 30 1962

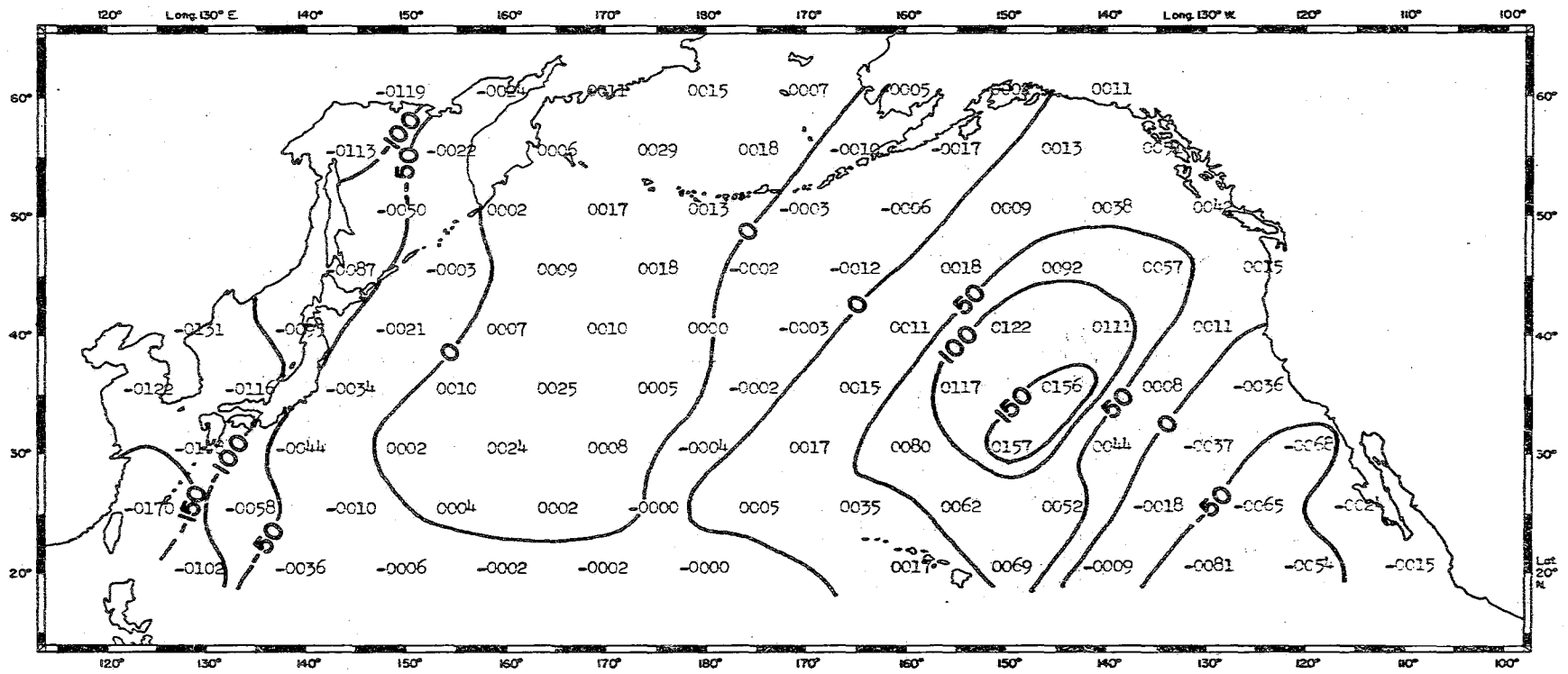

III. Zonal Component of Ekman Transport

Jan 1 Jan 30 1962

Jan 1 Jan 30 1962

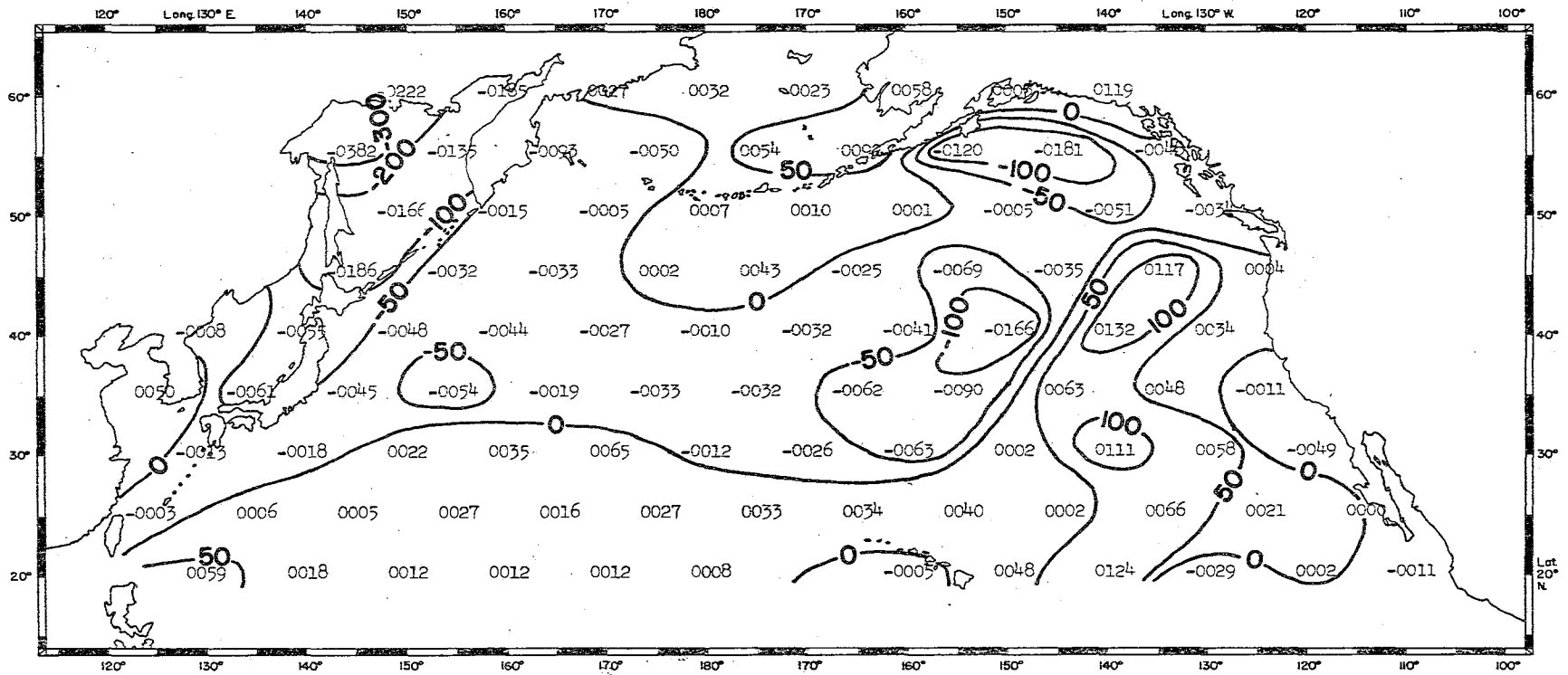

IV. Meridional Component of Total Transport

Jan 1 Jan 30 1962

Jan 1 Jan 30 1962

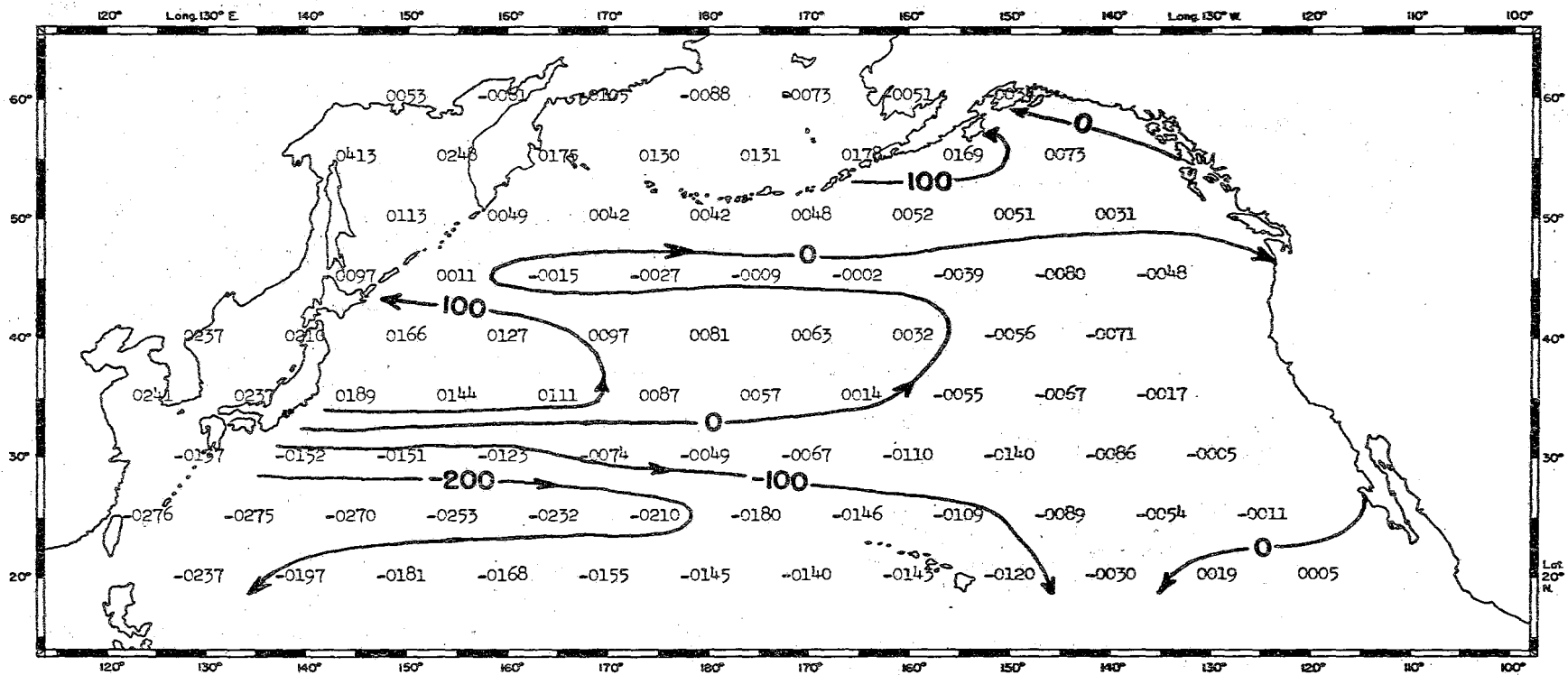

V. Integrated Total Transport

Jan 1 Jan 30 1962

Jan 1 Jan 30 1962

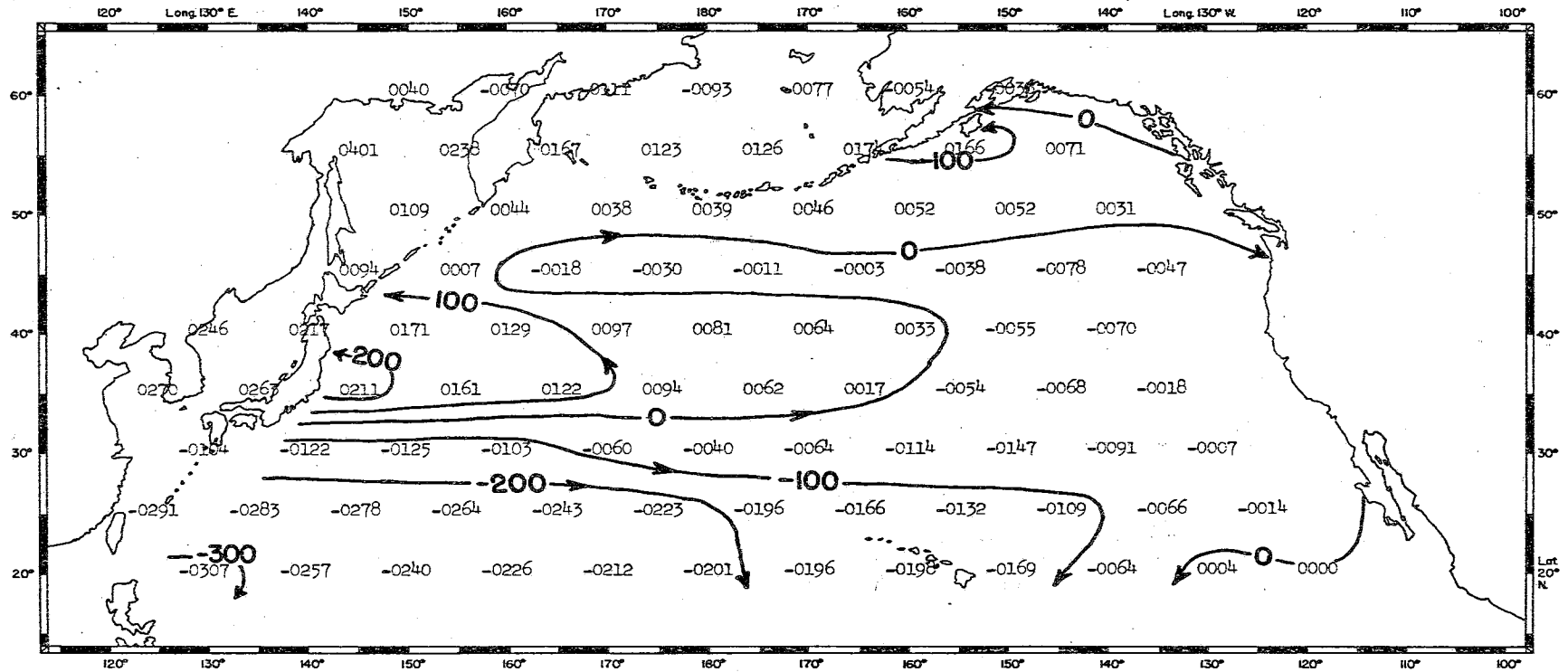

VI. Integrated Geostrophic Transport

Jan 1 Jan 30 1962

Jan 31 Mar 1 1962

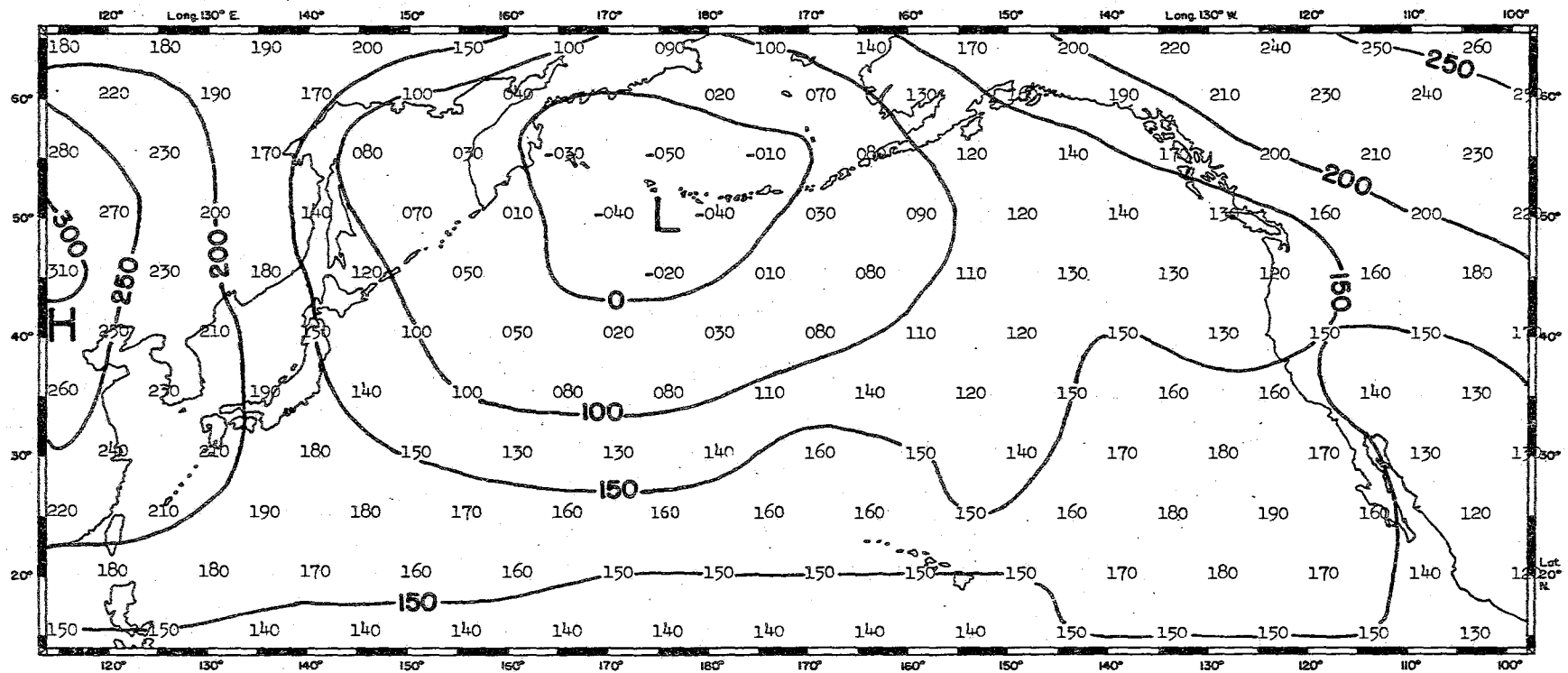

I. Atmospheric Pressure

Jan 31 Mar 1 1962

Jan 31 Mar 1 1962

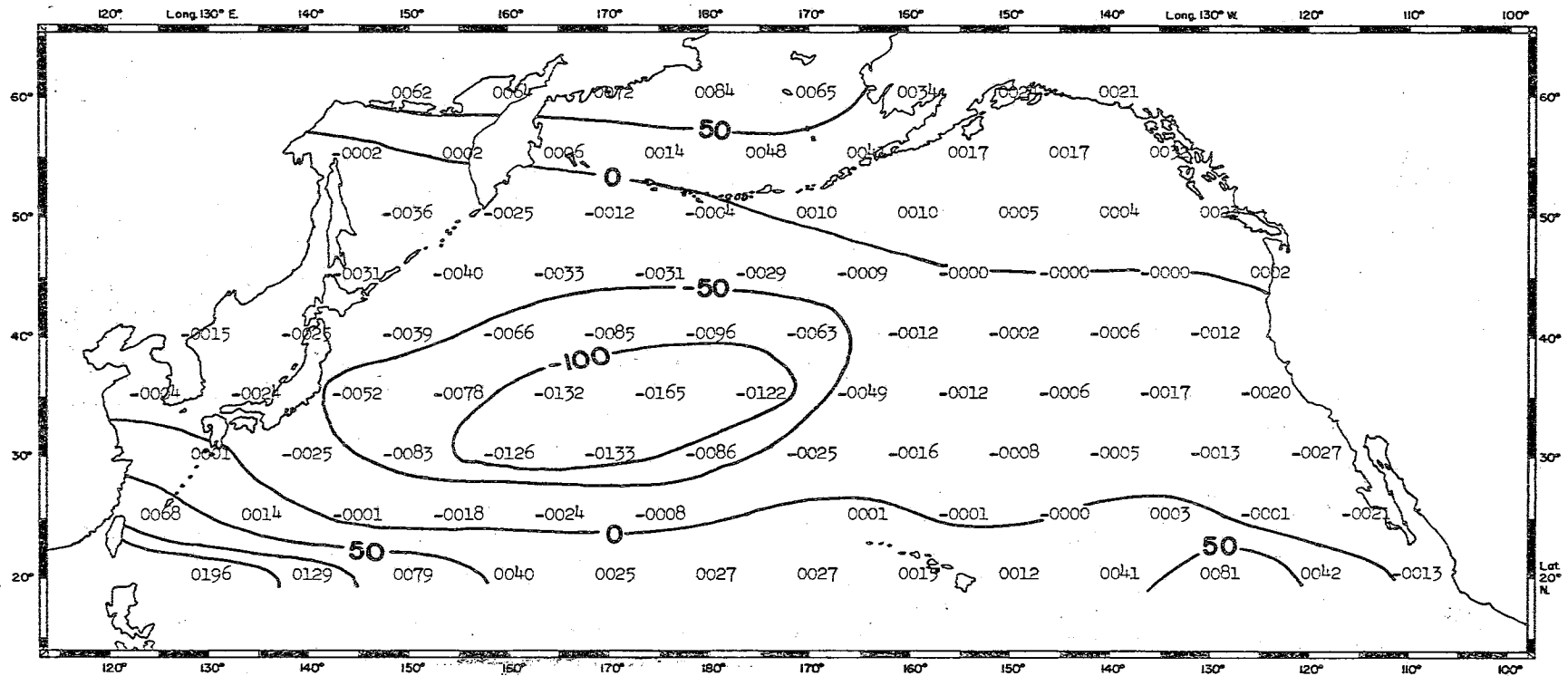

II. Meridional Component of Ekman Transport

Jan 31 Mar 1 1962

Jan 31 Mar 1 1962

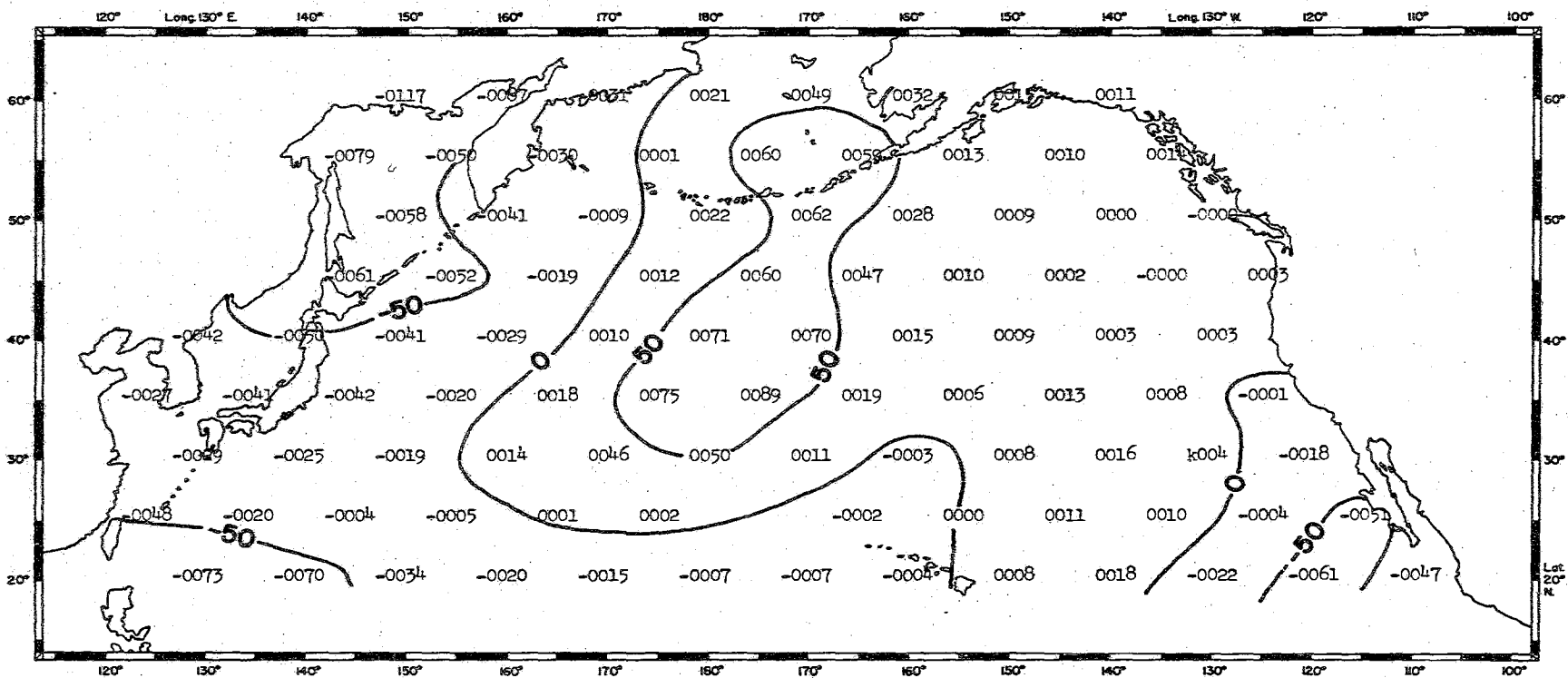

III. Zonal Component of Ekman Transport

Jan 31 Mar 1 1962

Jan 31 Mar 1 1962

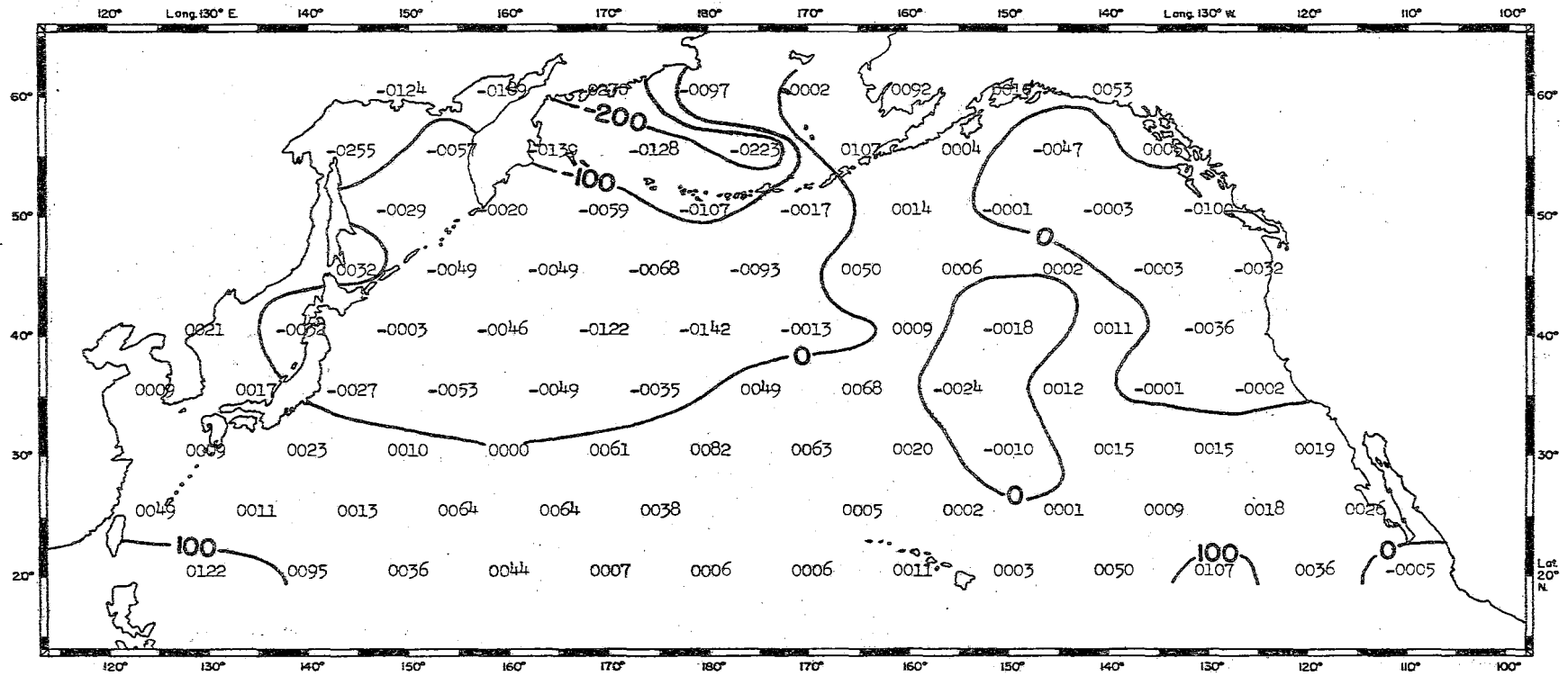

IV. Meridional Component of Total Transport

Jan 31 Mar 1 1962

Jan 31 Mar 1 1962

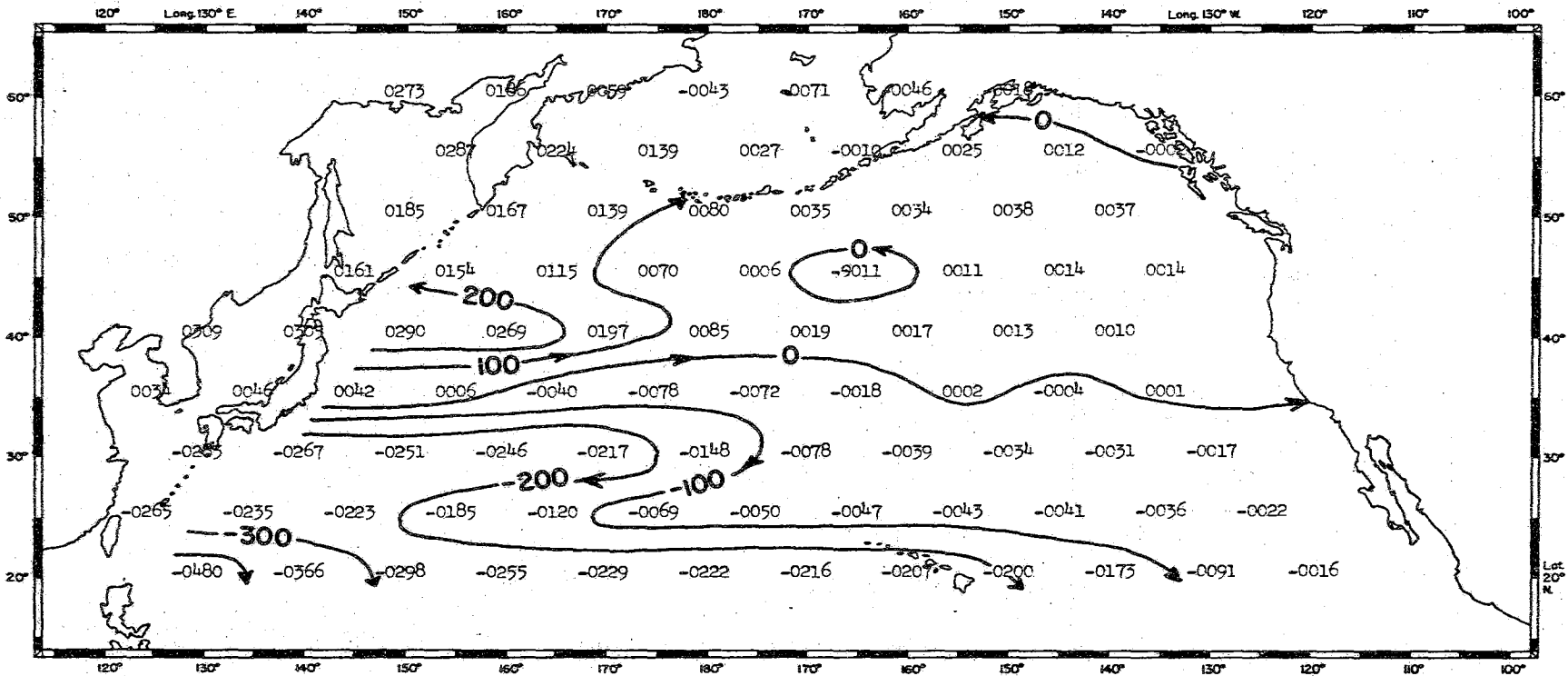

V. Integrated Total Transport

Jan 31 Mar 1 1962

Jan 31 Mar 1 1962

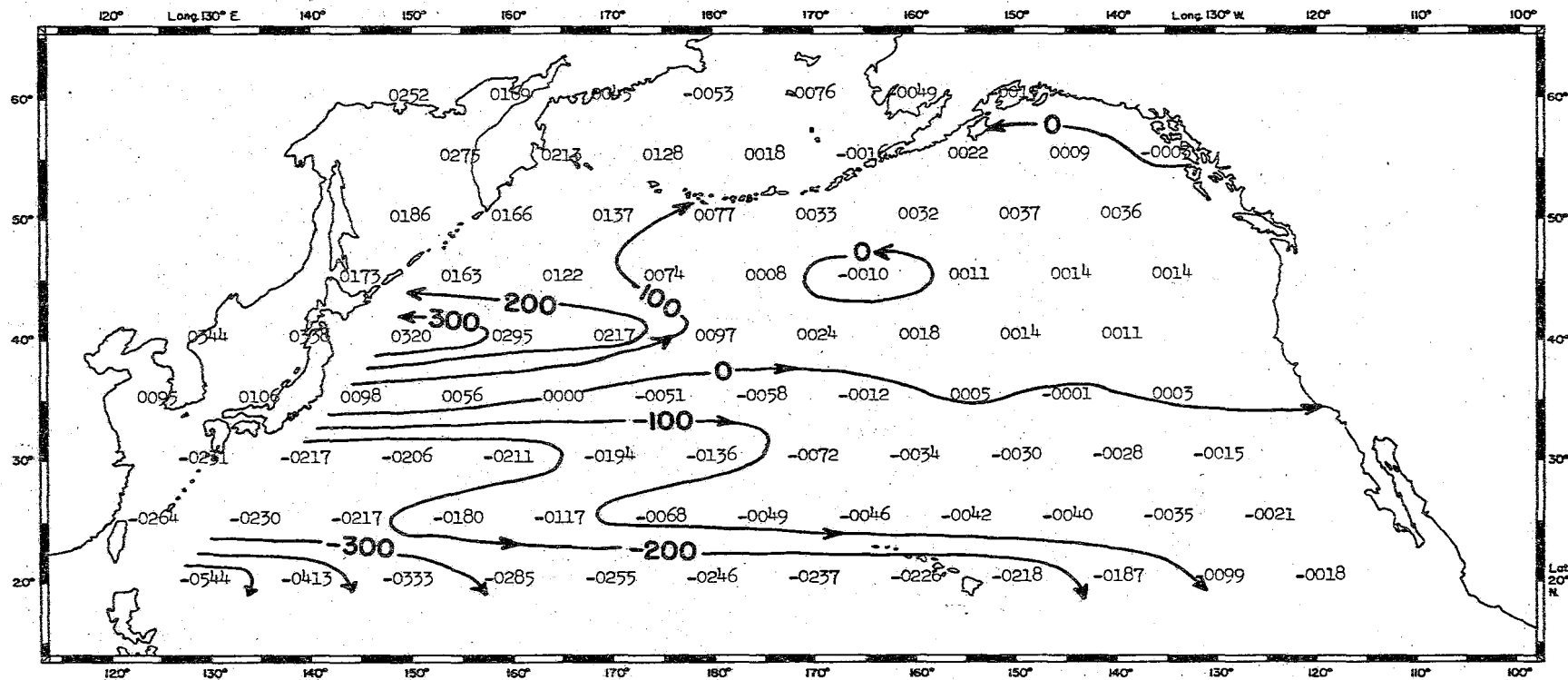

VI. Integrated Geostrophic Transport

Jan 31 Mar 1 1962

# MERIDIONAL COMPONENT OF EKMAN TRANSPORT in 10 metric tons/second/kilometer

--- 1962

(1955-60) mean  $\pm \sigma$

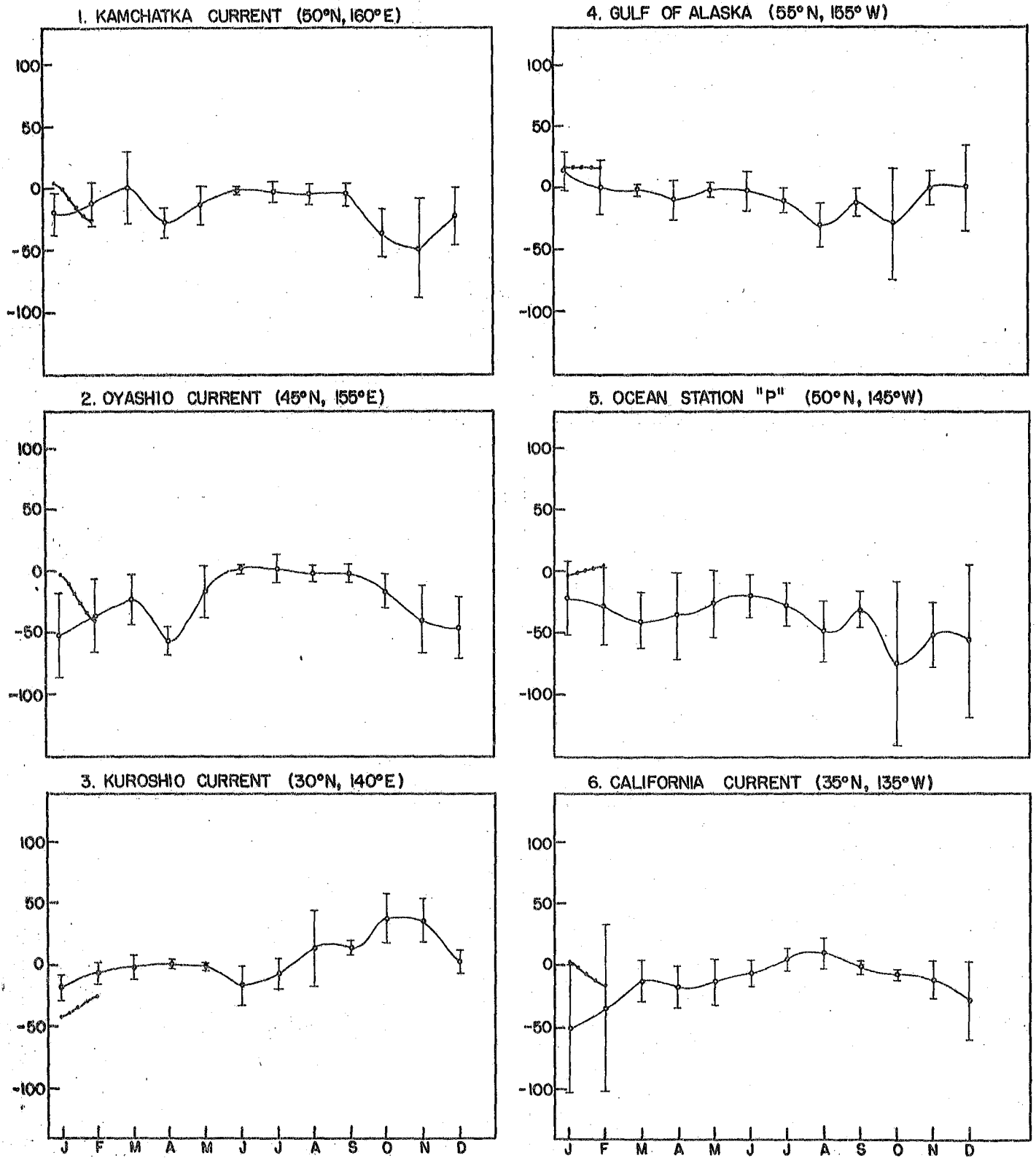

Figure 1

# ZONAL COMPONENT OF EKMAN TRANSPORT in 10 metric tons / second / kilometer

↔ 1962

| (1955-60) mean  $\pm \sigma$

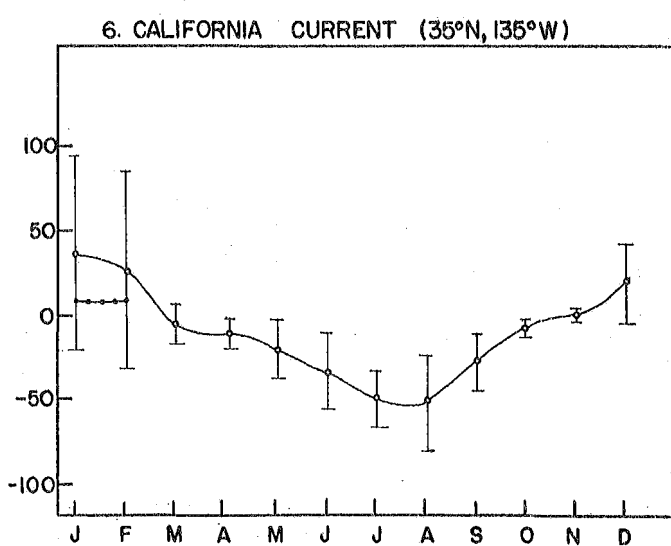
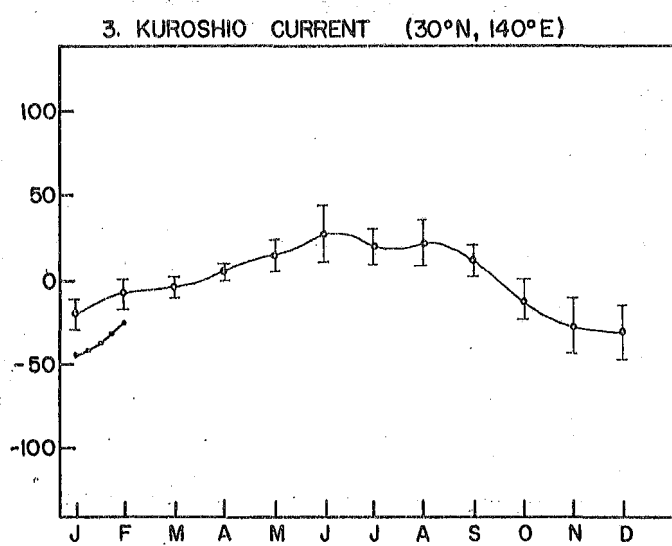
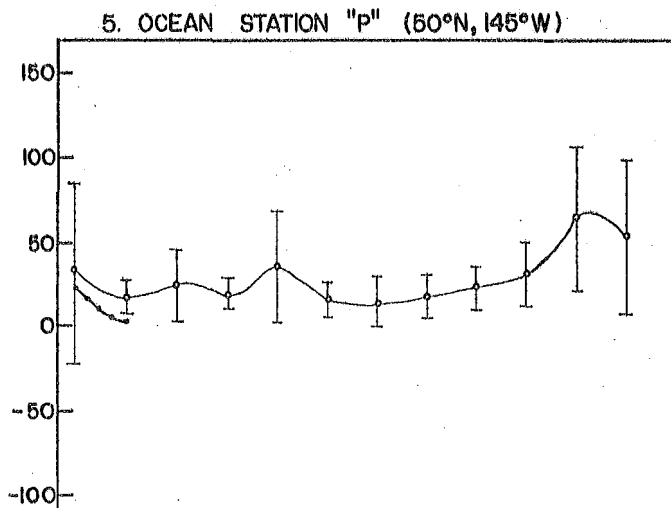
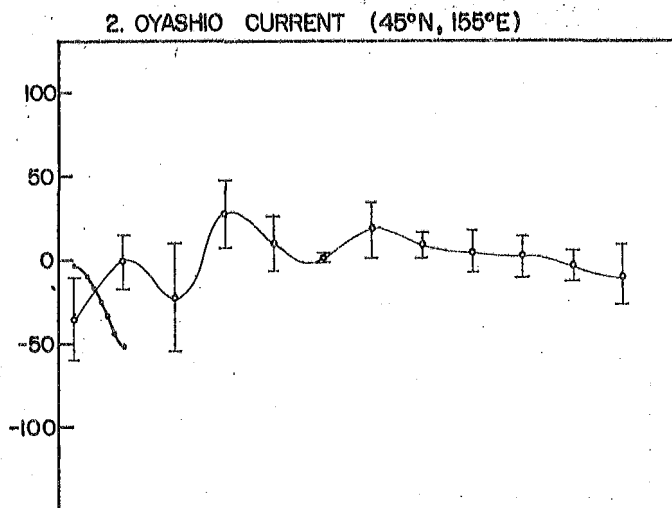
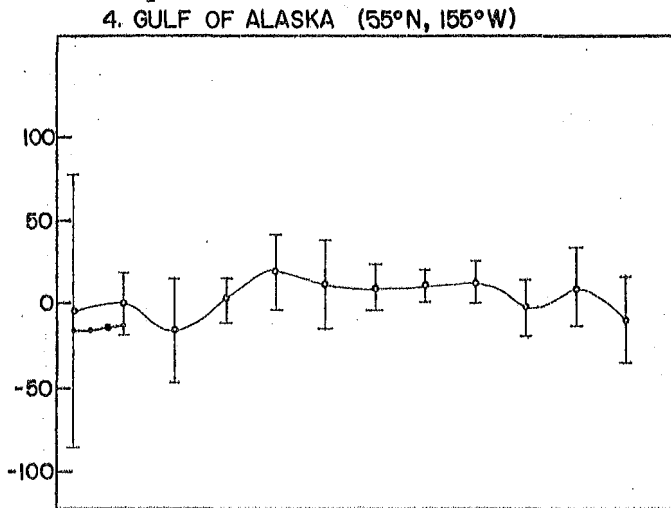
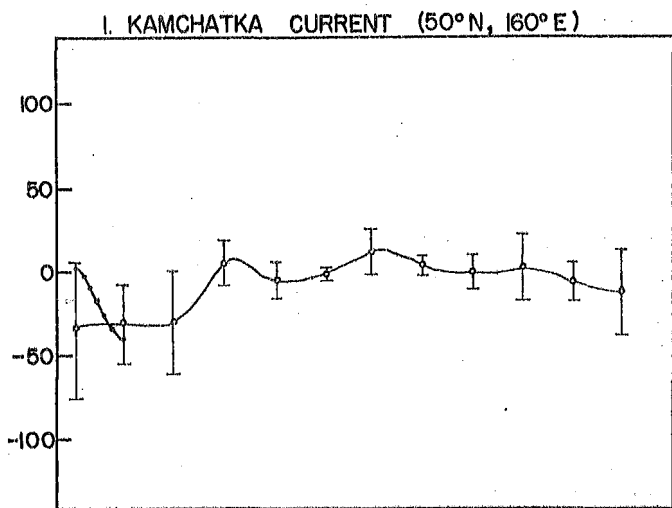

Figure 2

# MERIDIONAL COMPONENT OF TOTAL TRANSPORT in 100 metric tons/second / kilometer

●●●● 1962

⊥ (1955-60) mean ±σ

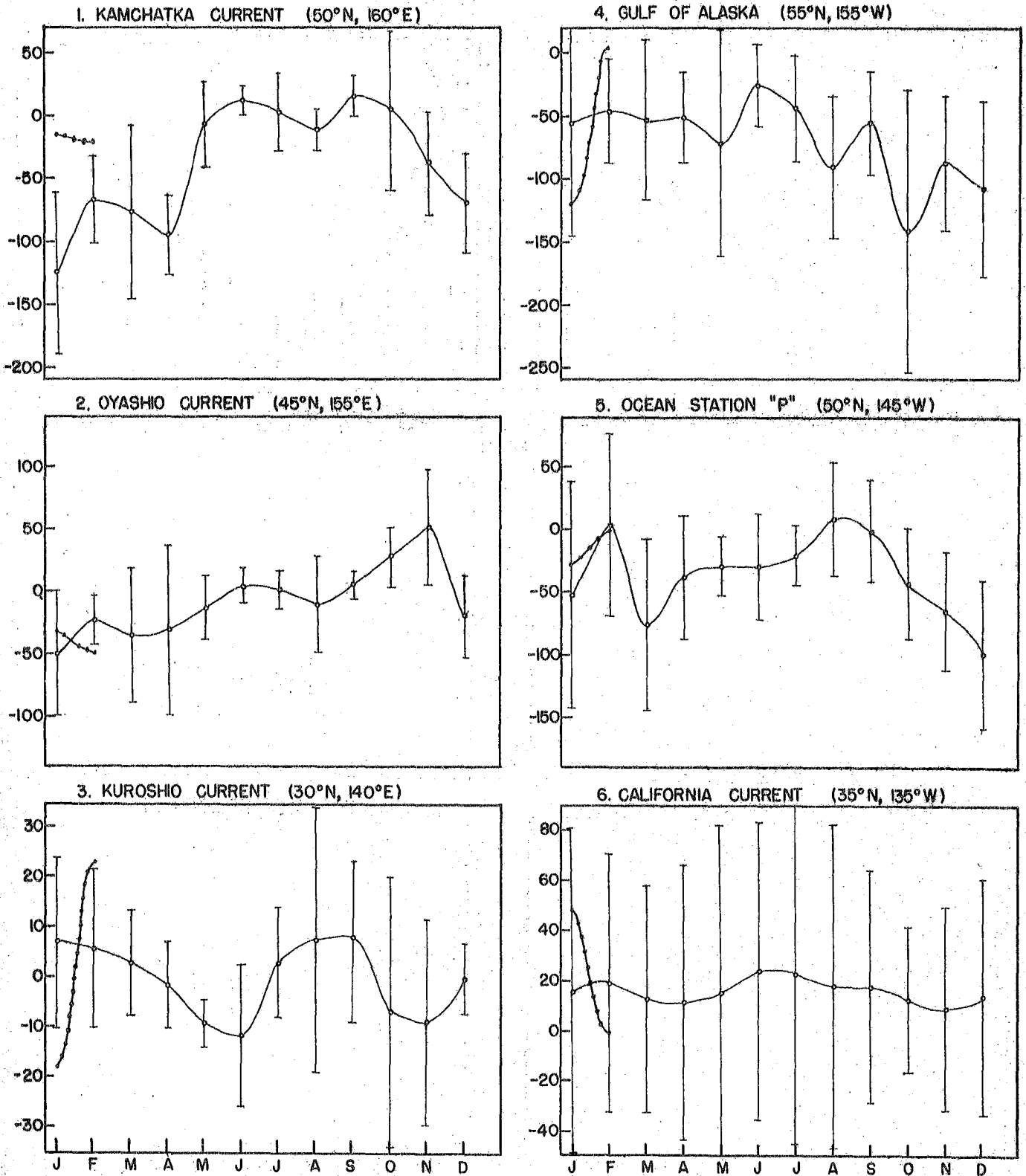

Figure 3

# INTEGRATED TOTAL TRANSPORT in millions of metric tons /second

—•— 1962

⊥ (1955-60) mean ±  $\sigma$

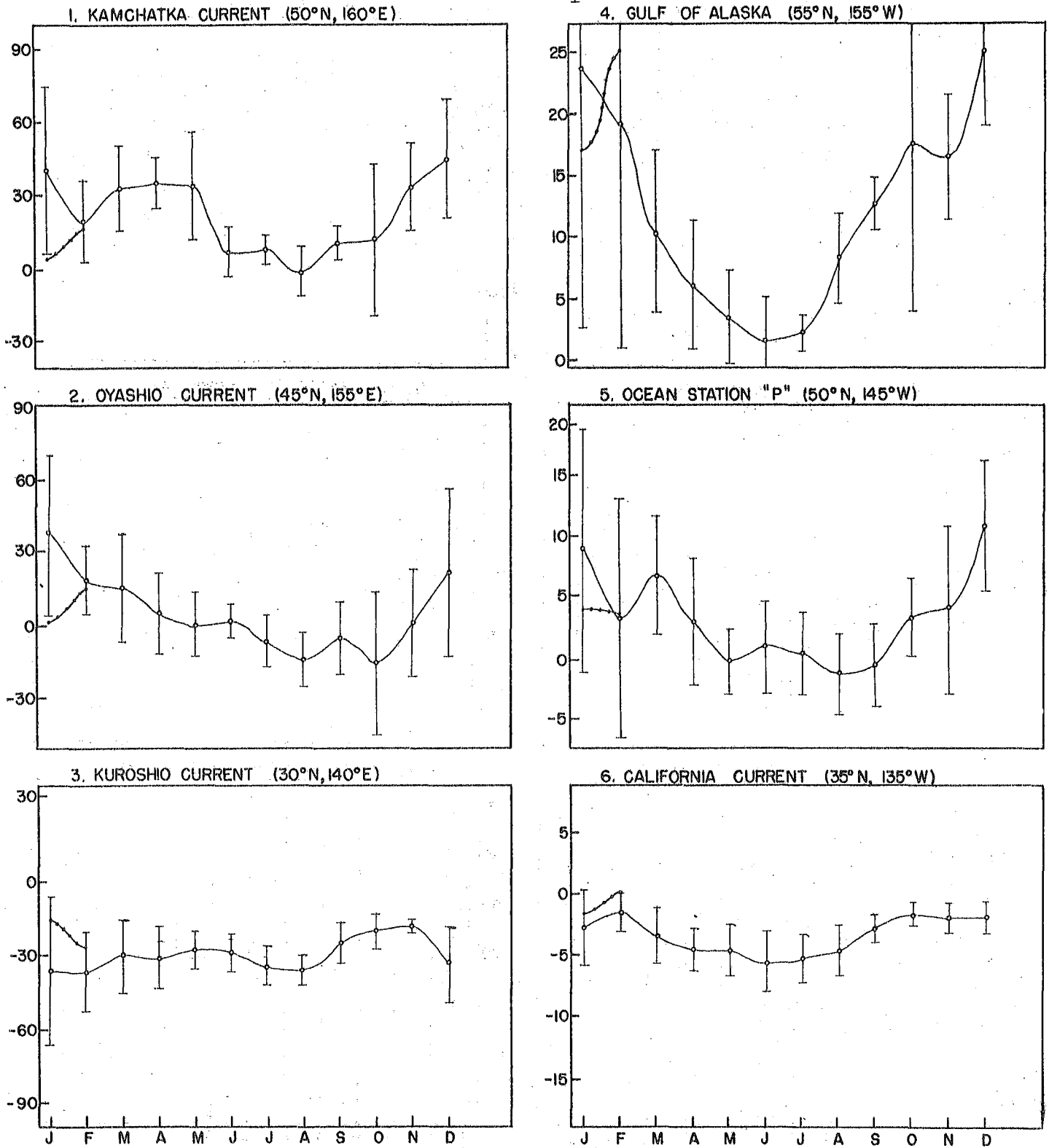

Figure 4

# INTEGRATED GEOSTROPHIC TRANSPORT in millions of metric tons/second

—●— 1962

| (1955-60) mean ±  $\sigma$

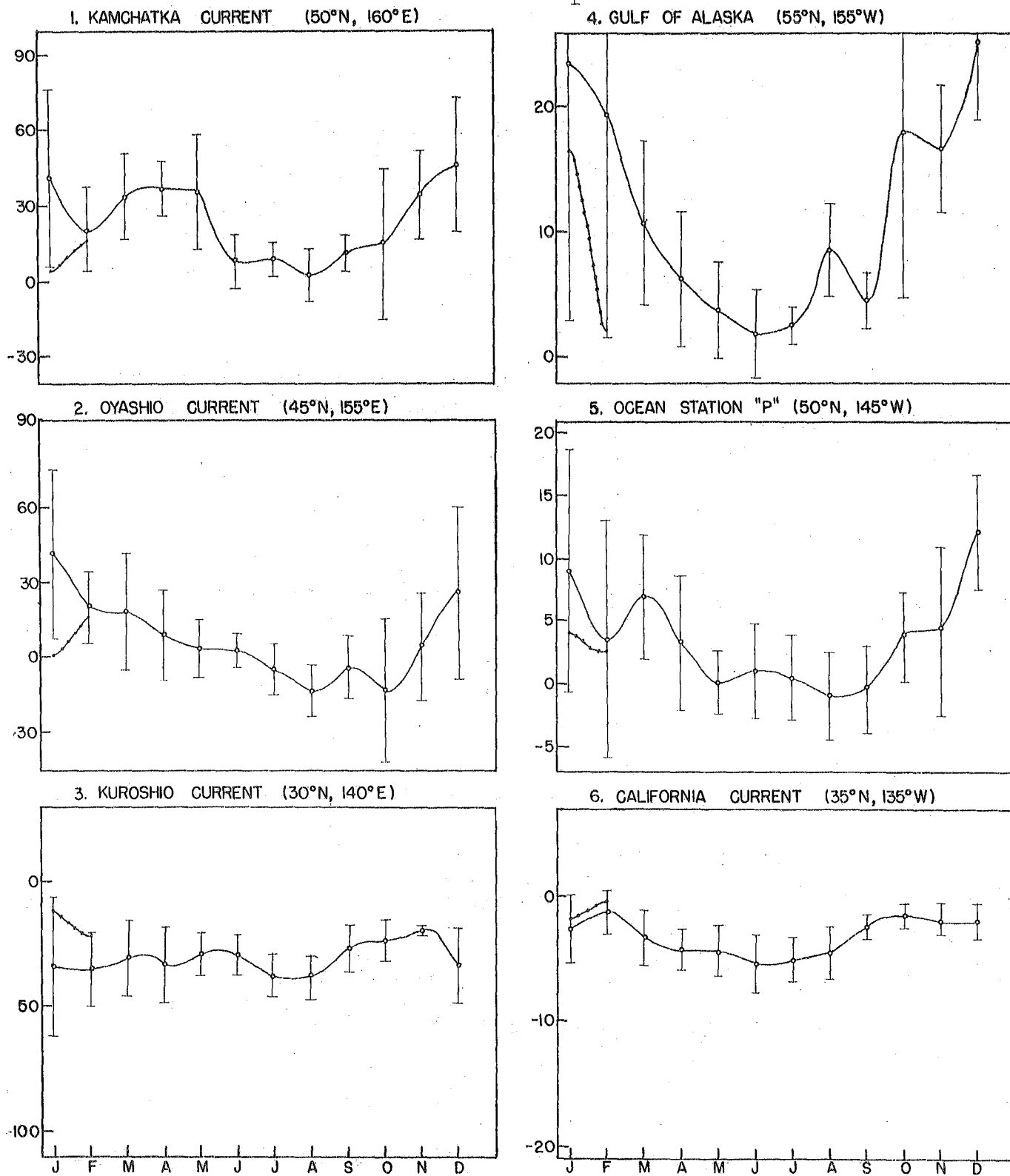

Figure 5

TREND OF INTEGRATED TOTAL TRANSPORT  
in millions of metric tons/second

—•— 1962

⌋ (1955-60) mean  $\pm \sigma$

1. KAMCHATKA CURRENT (50°N, 160°E)

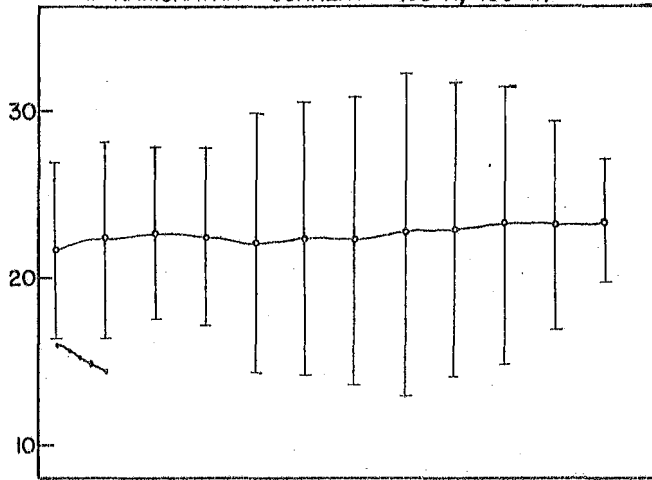

4. GULF OF ALASKA (55°N, 155°W)

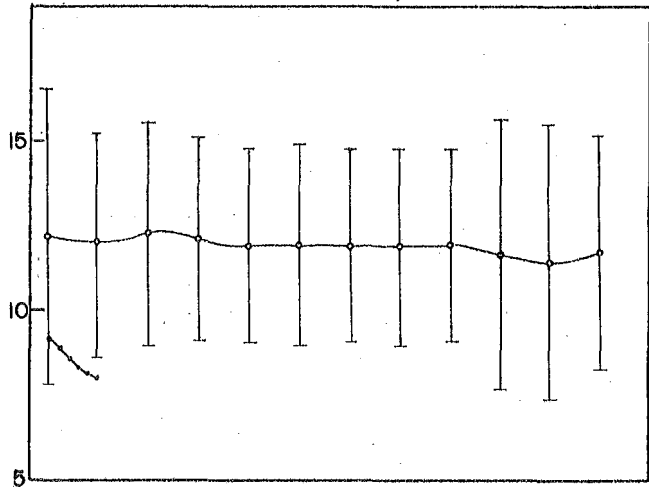

2. OYASHIO CURRENT (45°N, 155°E)

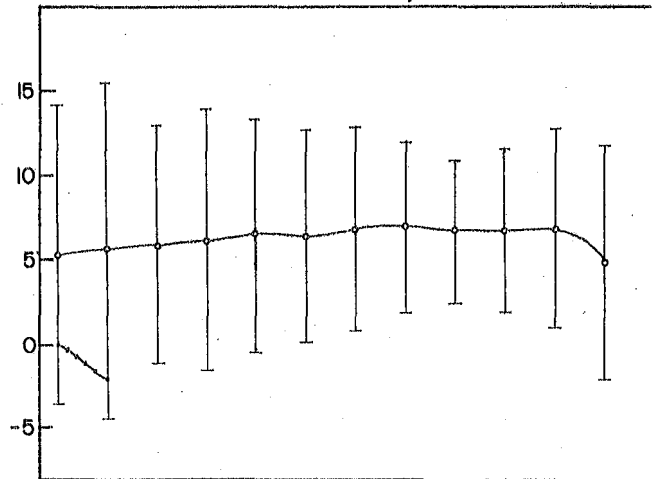

5. OCEAN STATION "P" (50°N, 145°W)

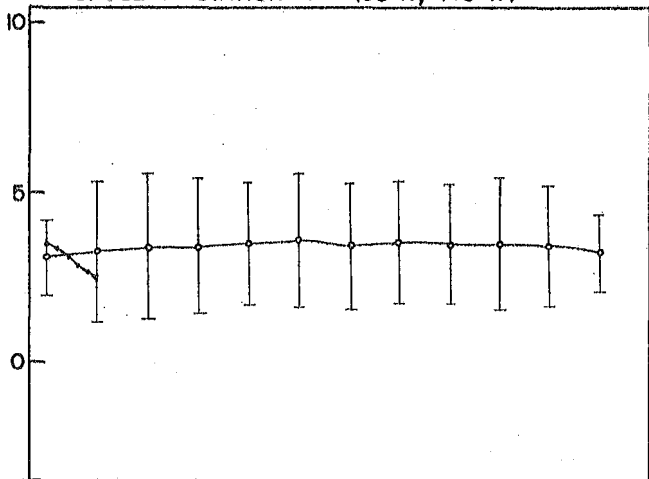

3. KUROSHIO CURRENT (30°N, 140°E)

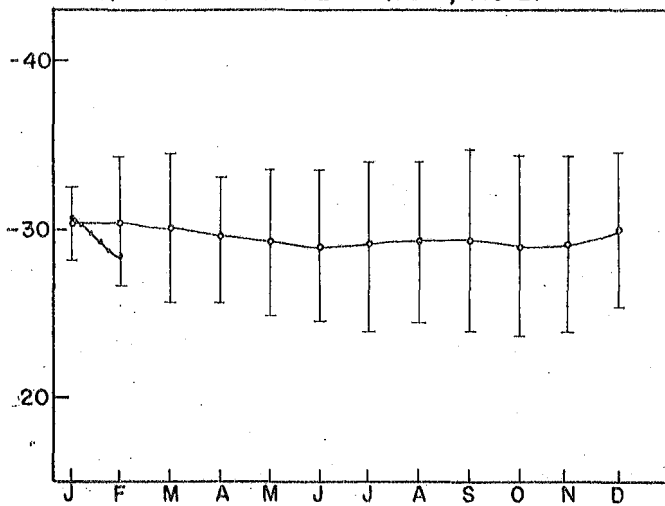

6. CALIFORNIA CURRENT (35°N, 135°W)

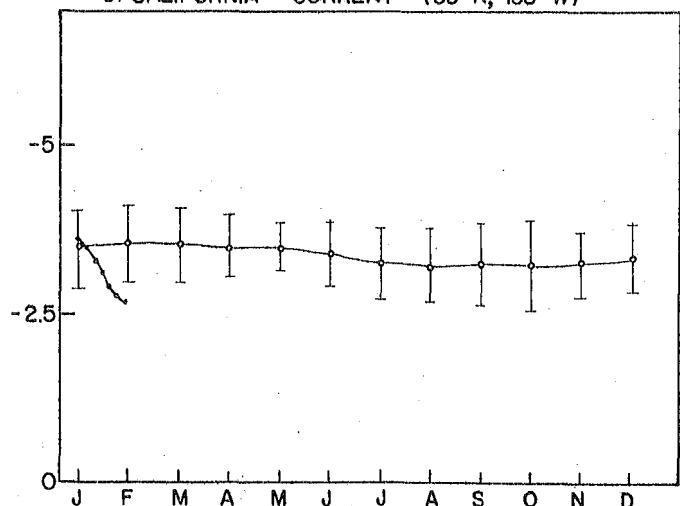

Figure 6

# TREND OF INTEGRATED GEOSTROPHIC TRANSPORT in millions of metric tons/second

—●— 1962

⊥ (1955-60) mean ± σ

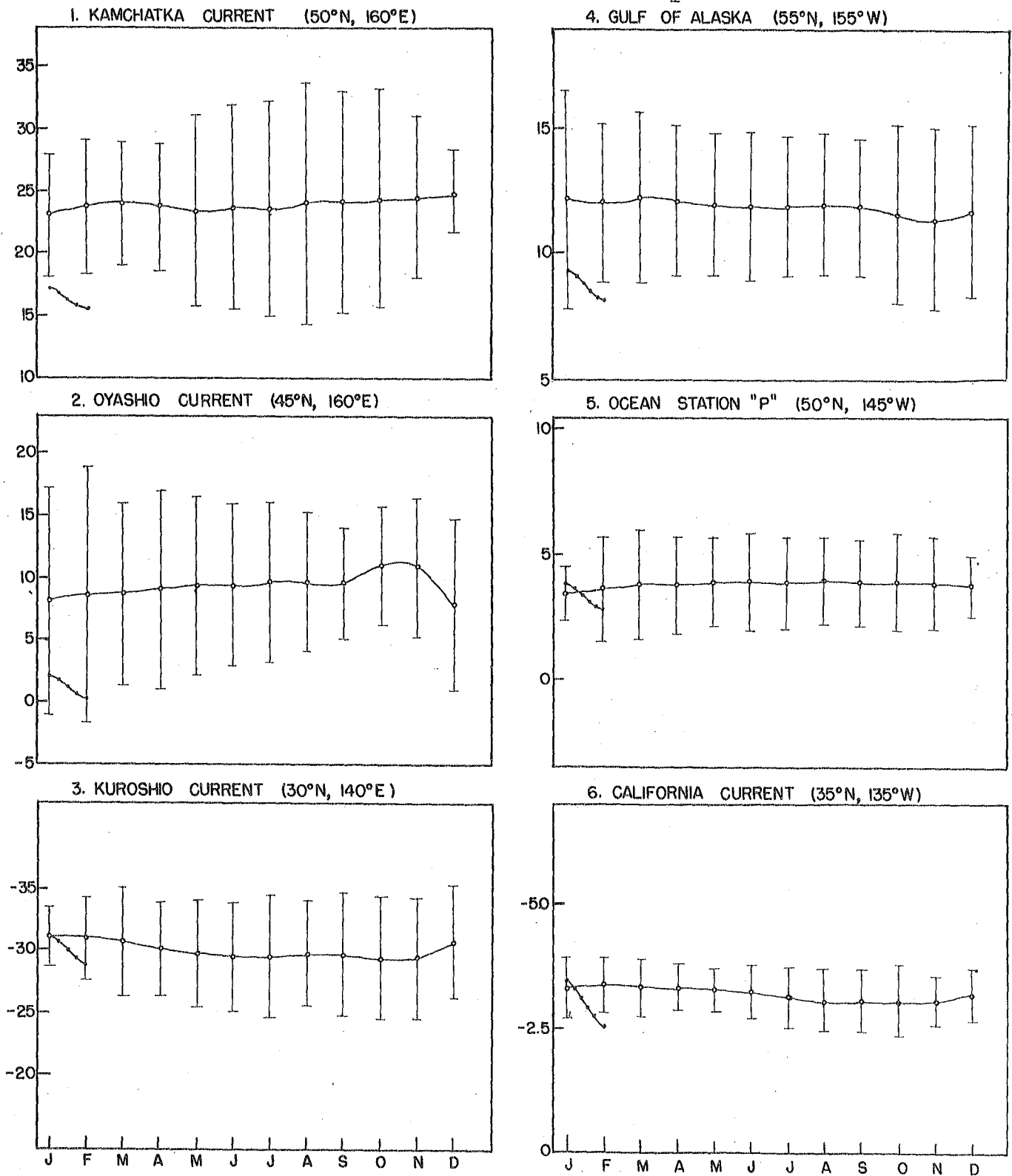

Figure 7

FISHERIES RESEARCH BOARD OF CANADA

Pacific Oceanographic Group  
Nanaimo, B. C.

Circular 1962 - 12

APR 24 1962

B.C. Coastal Seawater Temperatures  
January, February, March, 1962

Introduction

A weekly report of the daily seawater temperatures observed at four lightstations - Triple Island, McInnes Island, Entrance Island and Amphitrite Point - is broadcast on Wednesday mornings from radio station CBU. A report of the monthly mean seawater temperature (computed from the daily observations between the 1st and 27th) is received from three other lightstations, at Langara Island, Cape St. James and Kains Island. These monthly temperature reports are transmitted to the San Diego Biological Laboratory of the U.S. Bureau of Commercial Fisheries for use in their monthly sea-surface temperature charts of the Eastern Pacific Ocean.

This circular is the summary of the data for the three months of January, February and March, 1962.

The monthly mean temperature data are tabulated in Table I, along with various anomalies and the classification indices. These indices, recorded in the last column of the Table, represent the number of  $\frac{1}{2}$  standard deviation units there are in the anomaly between the monthly mean temperature and the 10-year grand monthly mean temperature; a positive (+) index indicates a warmer anomaly, a negative (-) index a colder anomaly.

Seawater temperature conditions in northern B.C. coastal waters

There was little significant regional difference between the conditions at the eight stations, except that reports from the four northern coast stations of Langara, Triple, Cape St. James and McInnes showed a more consistent colder-than-average tendency during the three-month period. Temperatures reached a minimum during the last week in February and started to warm up slightly during March. March monthly mean temperatures are the coldest of the three monthly reports. 1962 temperatures were 2 to 3 F° colder than for the same period in 1961. The monthly mean temperatures for these northern coast stations were generally in the -1 classification index which is not a significant departure from average but does indicate a tendency. (Significant differences would be over one standard deviation difference, i.e. +2 or -2 classifications).

Seawater temperature conditions in southern B.C. coastal waters

A warming-up period occurred in the southern coastal region during the first three weeks in February, so that the monthly mean temperatures for February were about 1 F° warmer than for January. The usual March warming-up tendency was added at this same temperature level so that in the southern region, January mean monthly temperatures were the coldest. Monthly mean temperatures for all three months were 1½ to 2 F° colder than in 1962. Classifications of anomalies with the 10-year average indicated that temperatures were slightly colder than average in January, but warmed up to average conditions in February and March.

General summary

Seawater temperatures on the west coast of Vancouver Island and in the Strait of Georgia warmed up in February, whilst in the northern B.C. regions temperatures cooled off until March. In the north, the anomaly with average temperatures was slightly colder for all three months, whereas in the south it was only colder than average in January, and average the other two months. Temperatures this year were 2 F° colder than in 1962.

H.J. Hollister

Table I. Monthly means and anomalies of seawater temperature (°F)  
January, February, March, 1962.

Station	Jan. 1962	Jan. '62- Dec. '61	Jan. diff. 1962-1961	Jan. 1962- 10 yr. av'ge	Classific'n/ Std. dev'n
Langara I.	43.4	-0.5	-1.4	+0.3	+0/1.5
Cape St. James	44.6	-0.5	-2.3	-0.7	-1/1.1
Triple I.	42.7	-0.8	-2.4	-1.1	-1/1.8
McInnes I.	42.9	-1.3	-2.3	-0.6**	-
Kains I.	44.6*	-0.3	-2.4	-1.1	-1/1.4
Amphitrite Pt.	44.8	-0.2	-2.7	-1.3	-1/1.5
Entrance I.	43.4	-1.7	-2.0	-0.9	-2/0.9
Departure Bay	42.9	-0.6	-1.2	-0.5	-1/0.8

Station	Feb. 1962	Feb.- Jan.	Feb. diff. 1962-1961	Feb. 1962- 10 yr. av'ge	Classific'n/ Std. dev'n
Langara I.	42.7*	-0.7	-1.9	-0.3	-0/1.3
Cape St. James	44.2*	-0.4	-1.6	-0.6	-1/1.2
Triple I.	41.8	-0.9	-2.9	-1.7	-2/1.6
McInnes I.	42.9	±0.0	-2.3	-0.6**	-
Kains I.	45.4*	+0.8	-1.6	-0.4	-0/1.3
Amphitrite Pt.	46.1	+1.3	-1.9	-0.1	-0/1.5
Entrance I.	44.2	+0.8	-1.4	±0.0	-0/0.9
Departure Bay	44.0	+1.1	-0.1	+0.3	+0/1.0

Station	Mar. 1962	Mar.- Feb.	Mar. diff. 1962-1961	Mar. 1962- 10 yr. av'ge	Classific'n/ Std. dev'n
Cape St. James	43.0*	-1.2	-2.8	-1.0	-1/1.4
Triple I.	41.8	±0.0	-3.2	-1.4	-2/1.2
McInnes I.	42.5	-0.4	-2.6	-1.1**	-
Kains I.	45.4*	±0.0	-1.7	-0.4	-0/1.3
Amphitrite Pt.	45.7	-0.4	-2.5	-0.8	-1/1.2
Entrance I.	44.7	+0.5	-1.4	-0.3	-0/0.9
Departure Bay	44.3	+0.3	-1.1	-0.4	-1/0.8

\*1-27 mean

\*\*8-yr. av'ge

A. H. ...

FISHERIES RESEARCH BOARD OF CANADA  
Pacific Oceanographic Group  
Nanaimo, B. C.

Circular 1962 - 13  
May 8, 1962

Productivity Cruise, C.N.A.V. "Oshawa" April 16-May 3, 1962

This cruise was made to study the transition zone known as the Sub-polar Front and further to determine the extent of the 'land mass effect' with respect to plant pigments over the coastal region from northern California to southern British Columbia. In another project an intensive study was made of the distribution of plant pigments in ocean water over an area of approximately 50 square miles.

1. The Sub-polar Front

The progressive lessening of the halocline and the deepening of the thermocline to a temperature maximum of 14° C at 100 m in sub-tropical water were recorded in this region. Plant pigments decreased from approximately 0.5 mg chl<sub>a</sub>/m<sup>3</sup> at the northern edge of the front to less than 0.2 mg chl<sub>a</sub>/m<sup>3</sup> in sub-tropical water. A pronounced accumulation of pigments at 100 m in sub-tropical water was noted. Particulate carbon profiles to 3000 m showed that sub-tropical water contained less particulate carbon, per unit volume of sea water, in the euphotic zone, than has been found in sub-arctic water. However the quantity of particulate carbon below 500 m was substantially the same in both regions. Surface soluble silicates decreased from 11 μg at Si/l at the northern edge of the Sub-polar Front to 3 μg at Si/l in sub-tropical water. Nitrate, soluble organic, phytoplankton, zooplankton and heterotrophic samples were taken over this region and will be analyzed ashore.

2. Coastal regions

Lateral plant pigment profiles off the coast of northern California, Oregon and Washington showed that coastal chlorophyll a values of 1-10 mg/m<sup>3</sup> decreased sharply to less than 1 mg/m<sup>3</sup> at a distance of approximately 60 miles from the coast. This corresponds to a total depths of 200-500 m. In all cases, however, the immediate inshore water (ca. 40 m) showed less chlorophyll a than water situated approximately 20-30 miles off the coast. From bathythermograph and salinity data this phenomenon appeared to be associated with an upwelling of deep water in the immediate vicinity of the coast. The stability of the upwelling must further be assumed to be too low for maximum plant growth, such as occurred further from the coast.

3. Plant pigment distribution in an oceanic 50 sq mile area.

Twenty-seven plant pigment determinations were made over a 50 sq mile area of oceanic water. The distribution of pigments in this area showed approximately 100 per cent higher concentration of plants in the southern portion

A. H. ...

of the square than in the northern portion. Since silicates and salinities were the same in the four corners and centre of the square, it may be tentatively assumed that the distribution of plants reflected a distribution in the zooplankton population because of grazing.

T.R. Parsons.

*H. Needler*

FISHERIES RESEARCH BOARD OF CANADA  
Pacific Oceanographic Group  
Nanaimo, B. C.

Circular 1962 - 14  
May 14, 1962.

Transport calculations for the North Pacific Ocean  
March 1962

Sverdrup (1947), Stommel (1948), and Munk (1950) have shown that the total steady-state transport of mass in the ocean depends primarily on the curl of the wind stress components acting on the surface of the ocean. Calculations have been performed to estimate the wind stress over the surface of the ocean by computing mean geostrophic winds from pressure differences between grid points, applying a transformation to estimate surface winds and using a "square law" formula to relate wind speeds to surface stresses (Fofonoff, MS 1960, 1961). The purpose of these calculations is two-fold. First, to find out how long an averaging period is necessary to approach steady-state conditions and second, to gain some idea of the variability, both with latitude and time, of the transport that is imposed on the ocean by the atmosphere.

Detailed descriptions of the method used for evaluating the transports are given in the introduction to the annual volumes of transport computations (Fofonoff, MS 1960, 1961). The actual computer program for the calculation of mass transport is contained in the program manual M-1 (Fofonoff and Froese, MS 1960).

Six grid points in regions of special interest have been selected to evaluate the transport components for a given month in terms of mean values. They lie in the Gulf of Alaska (55° N, 155° W), Ocean Station "P" (average values at 50° N, 150° W and 50° N, 140° W), west of California Current (35° N, 135° W), adjacent to the Kuroshio Current (30° N, 160° E), the Oyashio Current (45° N, 155° E), and the Kamchatka Current (50° N, 160° E).

At each grid point the mean values and the standard deviations of the transport components from values for the same month from previous years are given in tabular form. In addition, the mean values of the integrated total and geostrophic transport for the month and eleven preceding months are given and compared with similar averages in previous years to indicate the long term trend of computed transport.

The departures of the monthly values from their means have been divided into three classes in terms of the number of standard deviations from the mean. The classes are:

Class 1: departure of less than one standard deviation from the mean (68% of values for a Gaussian distribution). Values falling in this range are termed "normal".

Class 2: departures of one to two standard deviations from the mean (17% of values for a Gaussian distribution). These values will be referred to as "abnormal".

*[Handwritten signature]*

Class 3: departures greater than two standard deviations from the mean (5% of values for a Gaussian distribution). Values whose variation falls in this range will be denoted as "extreme".

#### Transport charts

- I. Monthly mean sea-level atmospheric pressure given as the anomaly of mean atmospheric pressure from 1000 mbs. in units of 1/10 millibars.
- II. Meridional component of Ekman transport ( $V_E$ ) in units of 10 metric tons/km/sec.
- III. Zonal component of Ekman transport ( $U_E$ ) in units of 10 metric tons/km/sec.
- IV. Meridional component of total transport ( $V$ ) in units of 100 metric tons/km/sec.

The values shown on chart IV are  $-V$ .

- V. Integrated total transport ( $\Psi$ ) in units of 100,000 metric tons/sec.
- VI. Integrated geostrophic transport ( $\Psi_g$ ) in units of 100,000 metric tons/sec.

The convention of signs adopted is that northward and eastward transport shall be considered as positive and southward and westward flow shall be negative.

#### References

- Fofonoff, N.P. MS, 1960. Transport computations for the North Pacific Ocean 1955-58. Fish. Res. Bd. Canada, MS Rept., Oceanogr. and Limnol. Series, Nos. 77-80, 93 pp.
- MS, 1961. Transport computations for the North Pacific Ocean 1959. Fish. Res. Bd. Canada, MS Rept., Oceanogr. and Limnol. Series, No. 85, 181 pp.
- Fofonoff, N.P., and C. Froese. MS, 1960. Programs for oceanographic computations and data processing on the electronic digital computer ALWAC III-E. M-1 miscellaneous programs. Fish. Res. Bd. Canada, MS Rept., Oceanogr. and Limnol. Series, No. 72, 35 pp.
- Munk, W.H. 1950. On the wind-driven ocean circulation. J. Meteorol. L (2), 79-93.
- Stommel, H. 1948. The westward intensification of wind-driven ocean currents. Trans. Amer. Geophys. Union 29, (2): 202-206.
- Sverdrup, H.V. 1947. Wind-driven currents in a baroclinic ocean; with applications to the equatorial currents of the Eastern Pacific. Proc. Nat. Acad. Sc., 33 (11): 318-326.

Assessment of transport calculations for March, 1962.

The atmospheric pressure pattern for March 1962 featured a "low" centred near the Kamchatka Peninsula and a "high" over the eastern Pacific Ocean. For the past three years the "low" has been positioned in the Gulf of Alaska but in the previous five years it was further west. Thus March, 1962, resembles March of 1955-59 more closely than in recent years. The magnitudes of the pressure anomalies were not unusual for the month of March.

The transport components were generally "normal" compared to the 1955-60 means. The meridional component of Ekman transport for the Oyashio Current was "abnormal". The only "abnormal" components of integrated total and geostrophic transport were at Ocean Station "P".

The trends of integrated transport were differing more from the 1955-60 mean. As in February the trends for the Gulf of Alaska and the Kamchatka Current were "abnormal". The trends have become "abnormal" for the Oyashio Current and for the California Current they have developed from "abnormal" to "extreme". During the last twelve months it is seen that the Kamchatka Current has tended to be a weaker southward current and the mean current at 45° N, 155° E (referred to here as the Oyashio Current) has changed from a southward current to a northward current. This indicates that the location of meridional convergence has shifted to the north.

C.K. Ross

Table 1: A comparison of transport components at selected grid points with the average values for the same month from previous years.

1. Kamchatka Current (50° N, 160° E)						4. Gulf of Alaska (55° N, 155° W)					
Mar 1962	Mar 1961	Mar Mean (55-60)	$\sigma$	$\frac{ x-\bar{x} }{\sigma}$	class	Mar 1962	Mar 1961	Mar Mean (55-60)	$\sigma$	$\frac{ x-\bar{x} }{\sigma}$	class
$V_E$ -18	16	0	28.9	0.62	1	$V_E$ 0	1	-0.7	5.3	0.13	1
$U_E$ -3	-20	-29.5	30.0	0.88	1	$U_E$ 1	-24	-15.0	30.3	0.53	1
$-V$ -74	-25	-76.0	69.1	0.03	1	$-V$ -9	-66	-53.2	63.5	0.70	1
$\Psi$ 354	219	329.2	174.4	0.14	1	$\Psi$ 43	104	106.5	64.8	0.98	1
$\Phi$ 365	219	339.5	173.2	0.15	1	$\Phi$ 43	103	106.7	64.5	0.99	1
$\Phi_{10}$ 156.5	275.9	225.2	49.8	1.38	2	$\Phi_{10}$ 75.3	97.3	123.2	33.0	1.45	2
$\Phi_{20}$ 168.2	305.8	239.2	48.5	1.46	2	$\Phi_{20}$ 76.1	96.9	123.0	33.3	1.41	2
2. Oyashio Current (45° N, 155° E)						5. Ocean Station "P" (50° N, 145° W)					
Mar 1962	Mar 1961	Mar Mean (55-60)	$\sigma$	$\frac{ x-\bar{x} }{\sigma}$	class	Mar 1962	Mar 1961	Mar Mean (55-60)	$\sigma$	$\frac{ x-\bar{x} }{\sigma}$	class
$V_E$ -53	-12	-23.5	21.1	1.40	2	$V_E$ -24.5	-18.5	-40.7	22.3	0.73	1
$U_E$ 0	-19	-22.8	31.4	0.73	1	$U_E$ 13.5	2.5	24.7	22.1	0.51	1
$-V$ -41	-37	-35.8	52.6	0.10	1	$-V$ -25.5	-56.5	-76.5	67.6	0.75	1
$\Psi$ 136	368	149.5	225.2	0.06	1	$\Psi$ 11.0	76.5	65.8	47.3	1.16	2
$\Phi$ 176	388	181.2	230.9	0.02	1	$\Phi$ 12.5	78.0	69.7	48.8	1.17	2
$\Phi_{10}$ -39.9	98.8	58.0	69.8	1.40	2	$\Phi_{10}$ 19.5	61.9	34.6	21.8	0.69	1
$\Phi_{20}$ -14.7	128.8	87.4	71.6	1.43	2	$\Phi_{20}$ 22.2	68.7	37.6	21.5	0.72	1
3. Kuroshio Current (30° N, 140° E)						6. California Current (35° N, 135° W)					
Mar 1962	Mar 1961	Mar Mean (55-60)	$\sigma$	$\frac{ x-\bar{x} }{\sigma}$	class	Mar 1962	Mar 1961	Mar Mean (55-60)	$\sigma$	$\frac{ x-\bar{x} }{\sigma}$	class
$V_E$ -11	3	-3.3	10.0	0.77	1	$V_E$ -15	-95	-12.5	17.1	0.15	1
$U_E$ -3	-6	-4.8	6.3	0.29	1	$U_E$ -9	19	-4.2	10.9	0.44	1
$-V$ -7	-9	2.8	10.5	0.93	1	$-V$ 23	124	12.5	45.3	0.23	1
$\Psi$ -269	-389	-303.7	153.6	0.23	1	$\Psi$ -30	-84	-33.8	22.0	0.17	1
$\Phi$ -267	-370	-306.5	149.3	0.26	1	$\Phi$ -28	-77	-32.2	21.7	0.19	1
$\Phi_{10}$ -273.1	-329.8	-301.4	43.0	0.66	1	$\Phi_{10}$ -22.5	-40.3	-35.0	5.4	2.32	3
$\Phi_{20}$ -279.5	-327.5	-306.6	43.8	0.62	1	$\Phi_{20}$ -21.4	-38.3	-32.8	5.5	2.07	3

$\sigma$  is based on (55-60) values.

$\frac{|x-\bar{x}|}{\sigma}$  denotes deviation from mean in terms of standard deviation

$\Psi, \Phi$  are trends of integrated transports based on the straight mean of the month and the eleven preceding months.

Classes are explained on pages 1-2.

Mar 1 Mar 30 1962

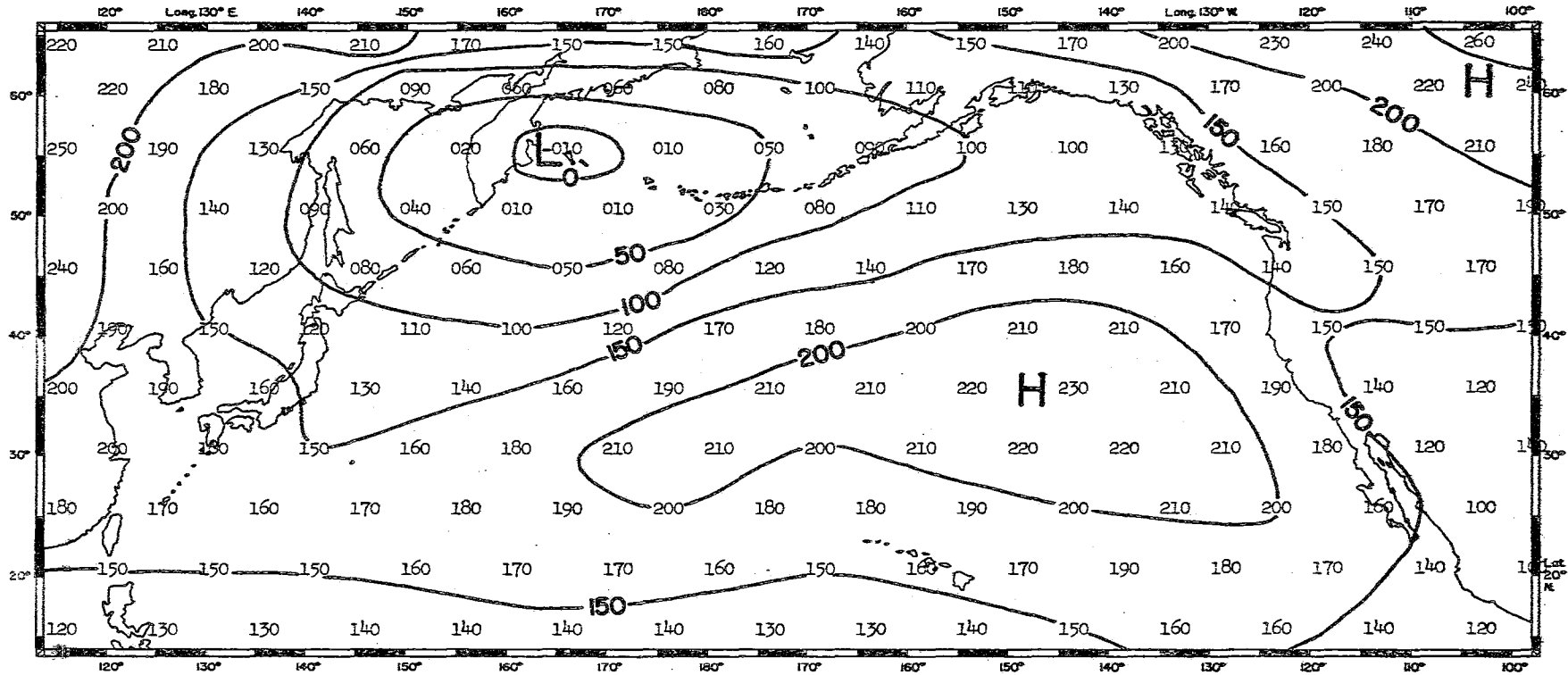

I. Atmospheric Pressure

Mar 1 Mar 30 1962

Mar 1 Mar 30 1962

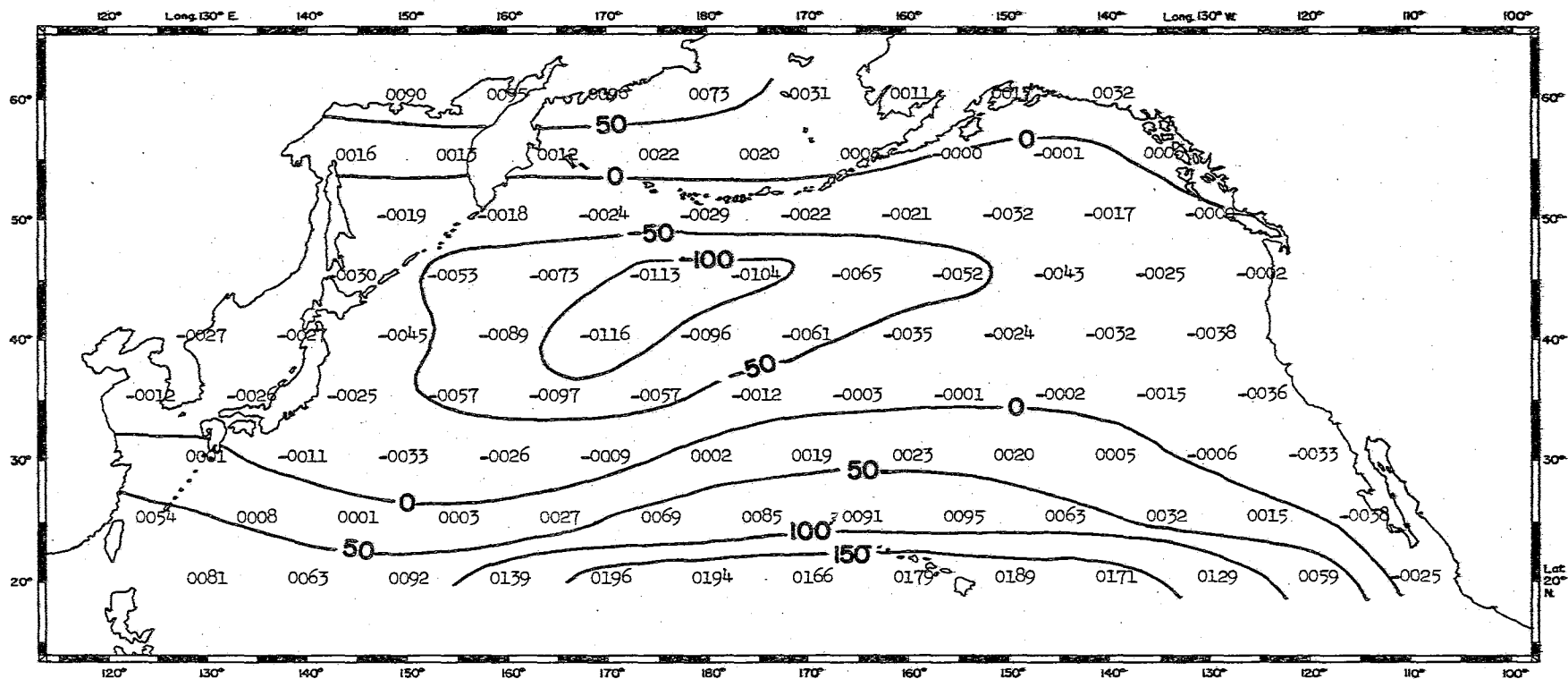

II. Meridional Component of Ekman Transport

Mar 1 Mar 30 1962

Mar 1 Mar 30 1962

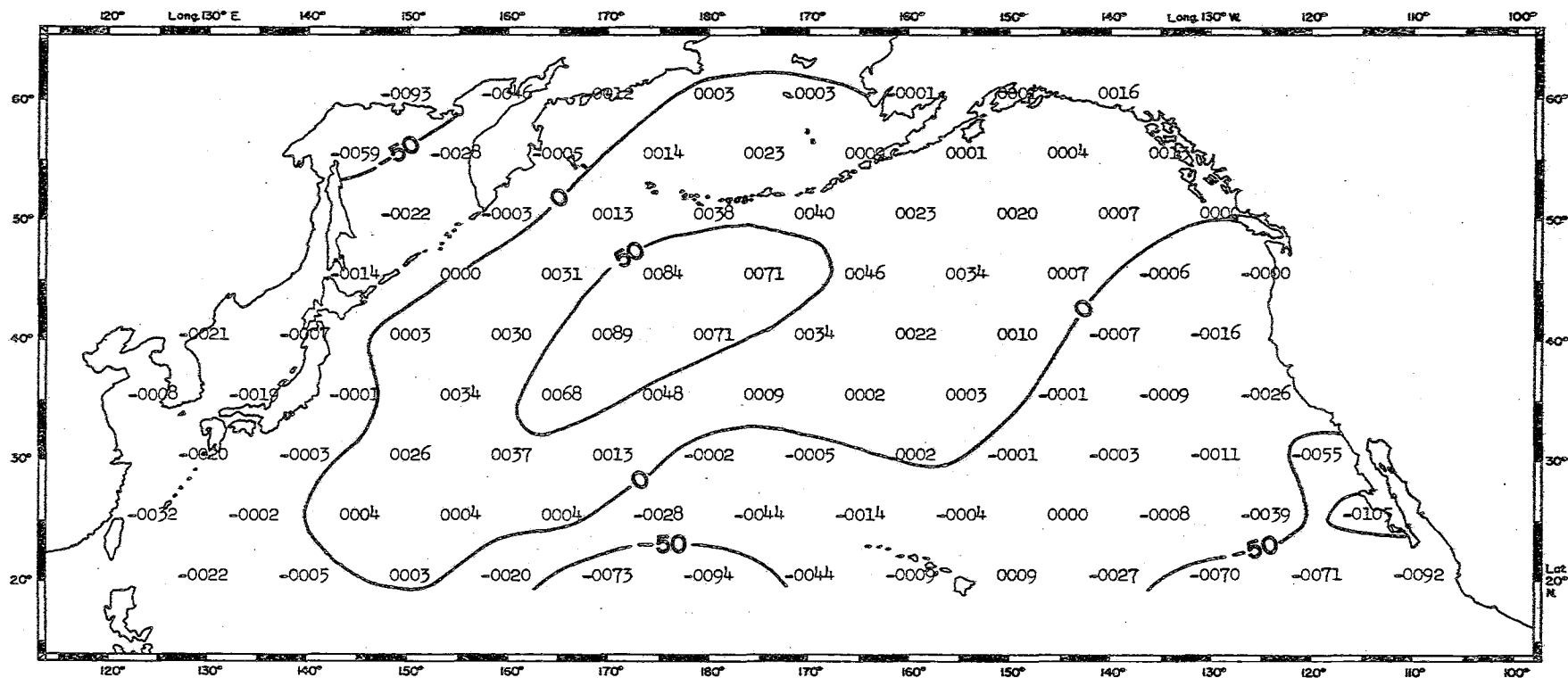

III. Zonal Component of Ekman Transport

Mar 1 Mar 30 1962

Mar 1 Mar 30 1962

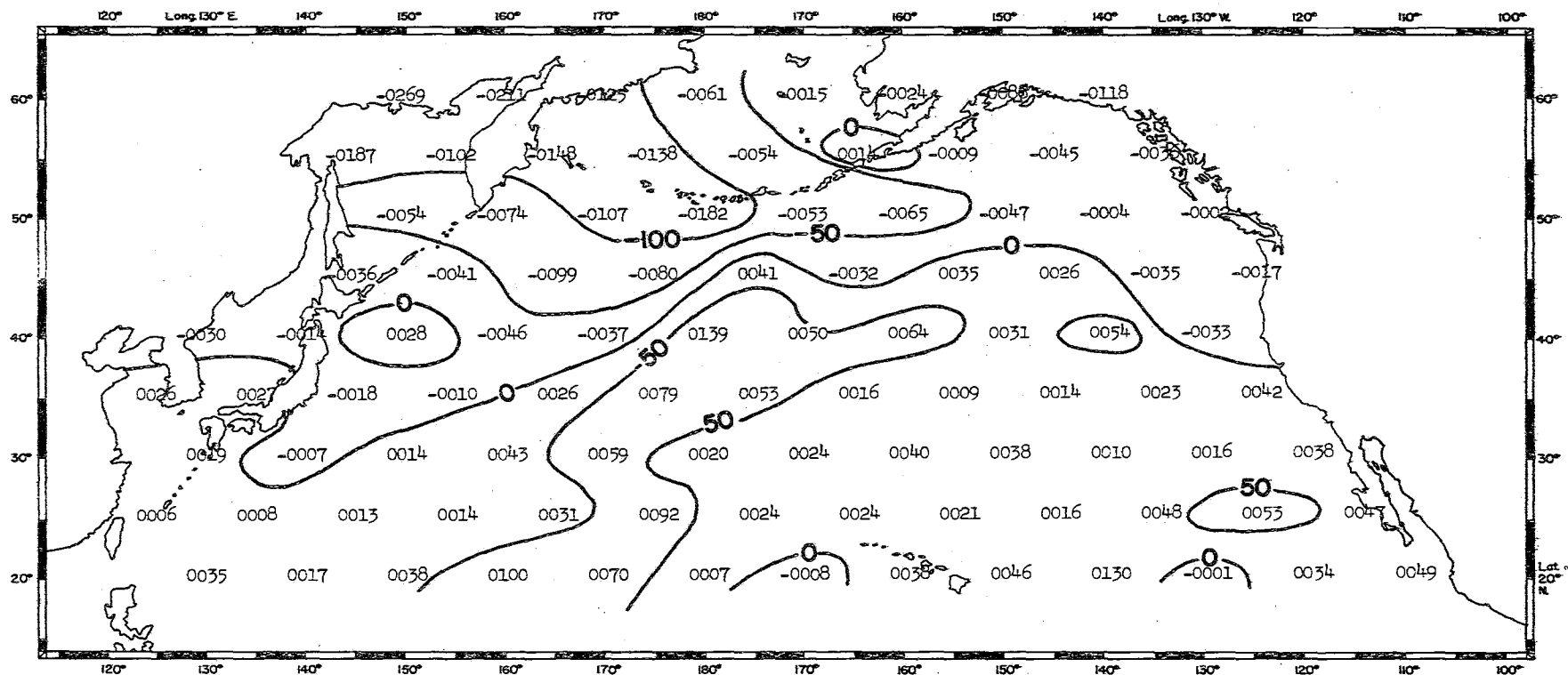

IV. Meridional Component of Total Transport

Mar 1 Mar 30 1962

Mar 1 Mar 30 1962

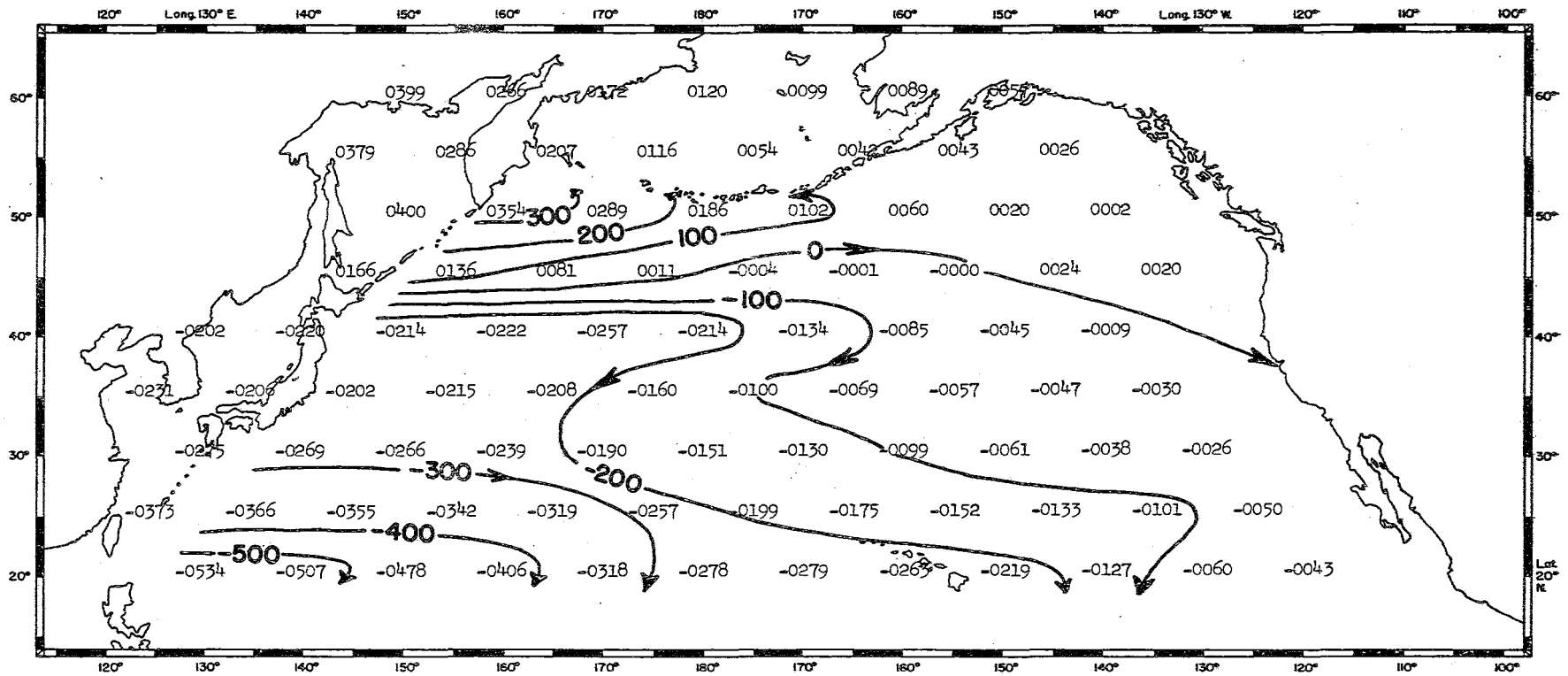

V. Integrated Total Transport

Mar 1 Mar 30 1962

Mar 1 Mar 30 1962

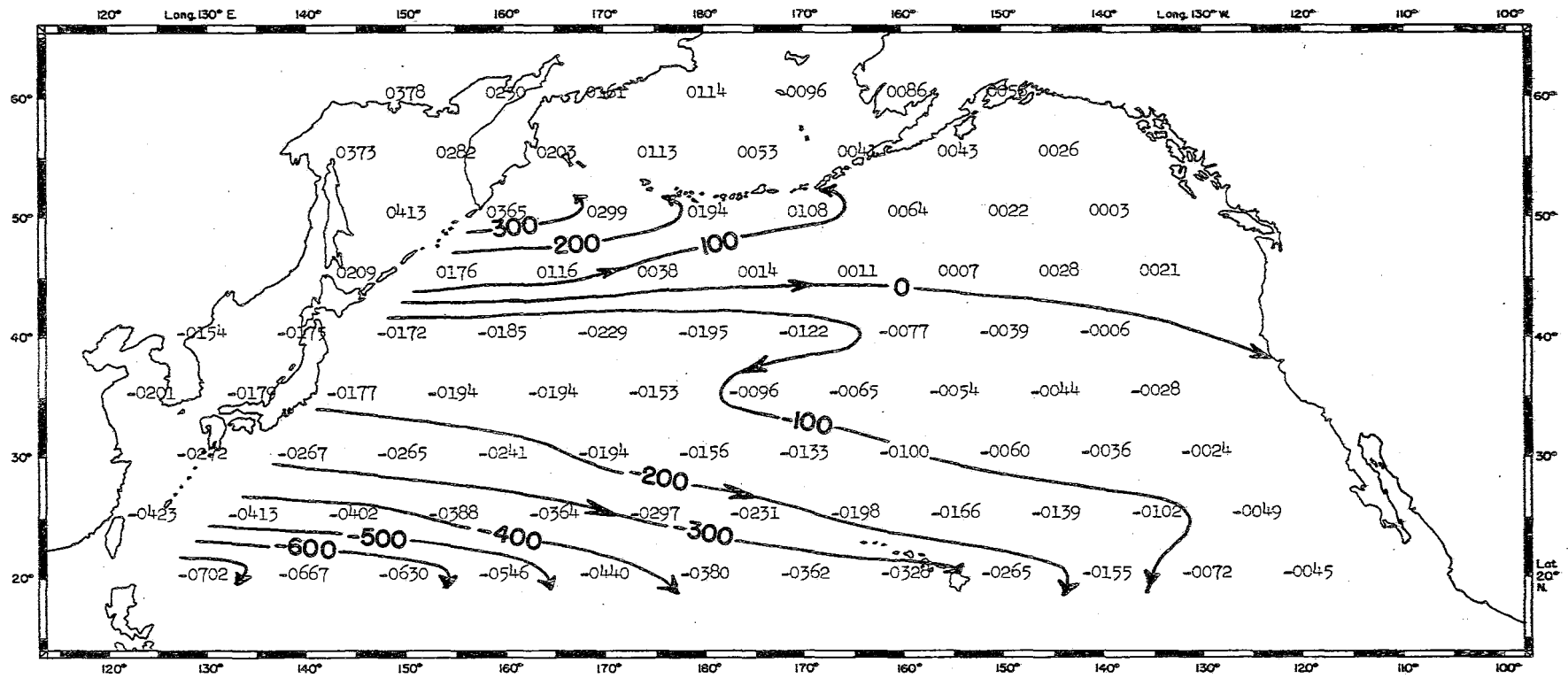

VI. Integrated Geostrophic Transport

Mar 1 Mar 30 1962

# MERIDIONAL COMPONENT OF EKMAN TRANSPORT in 10 metric tons/second/kilometer

----- 1962

(1955-60) mean  $\pm \sigma$

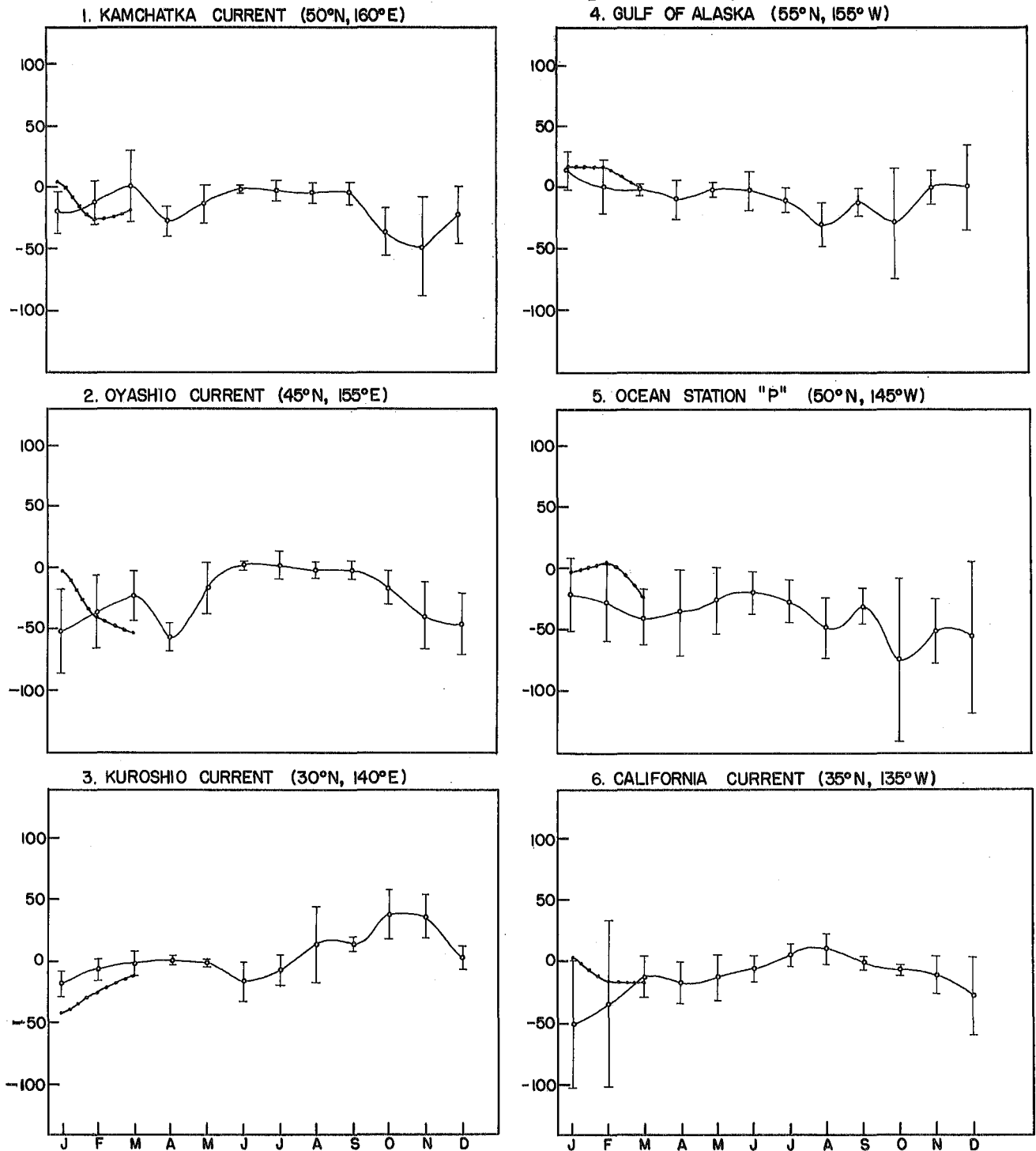

Figure 1

## ZONAL COMPONENT OF EKMAN TRANSPORT in 10 metric tons / second / kilometer

--- 1962

⊥ (1955-60) mean ±σ

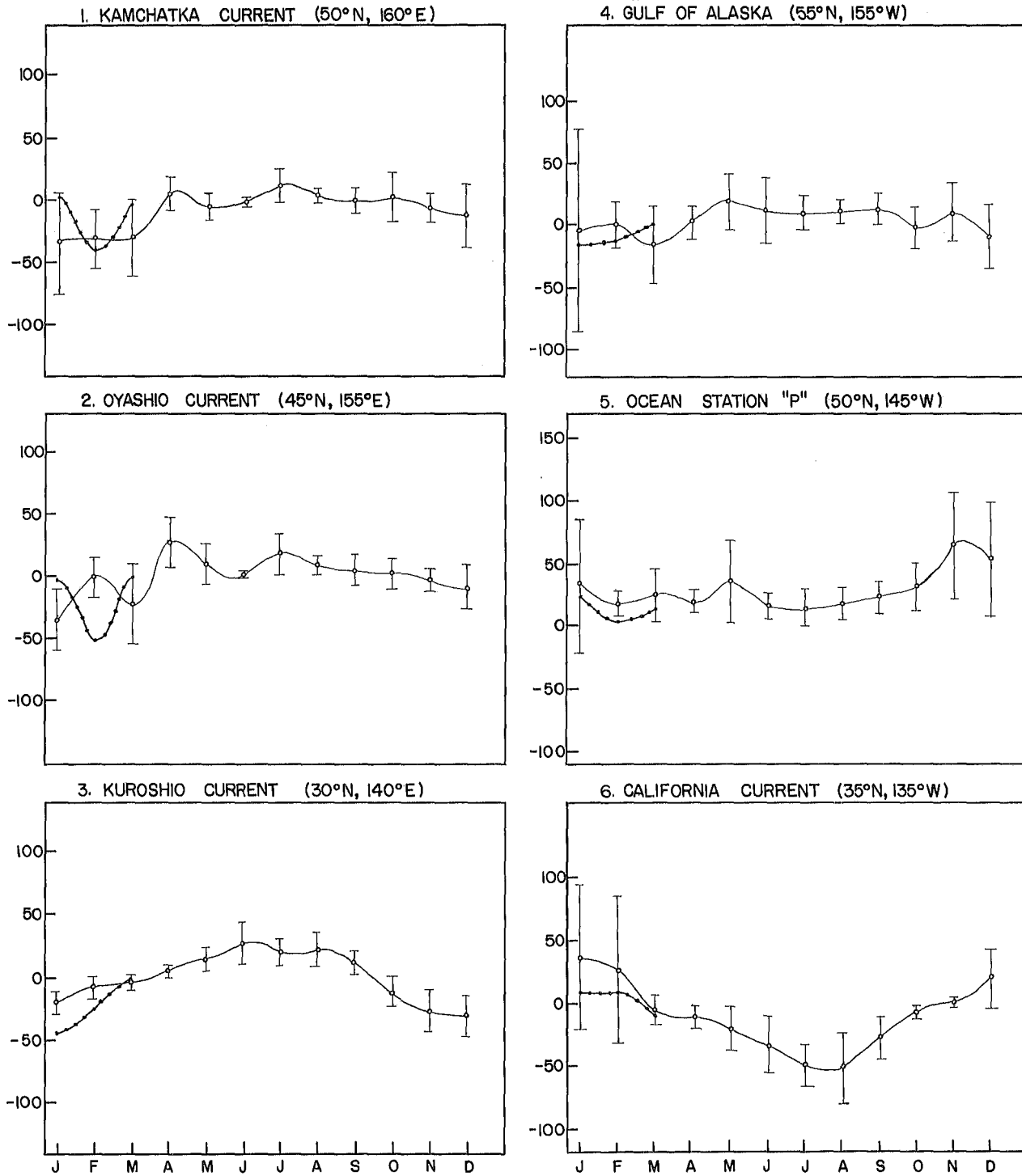

Figure 2

MERIDIONAL COMPONENT OF TOTAL TRANSPORT  
in 100 metric tons/second / kilometer

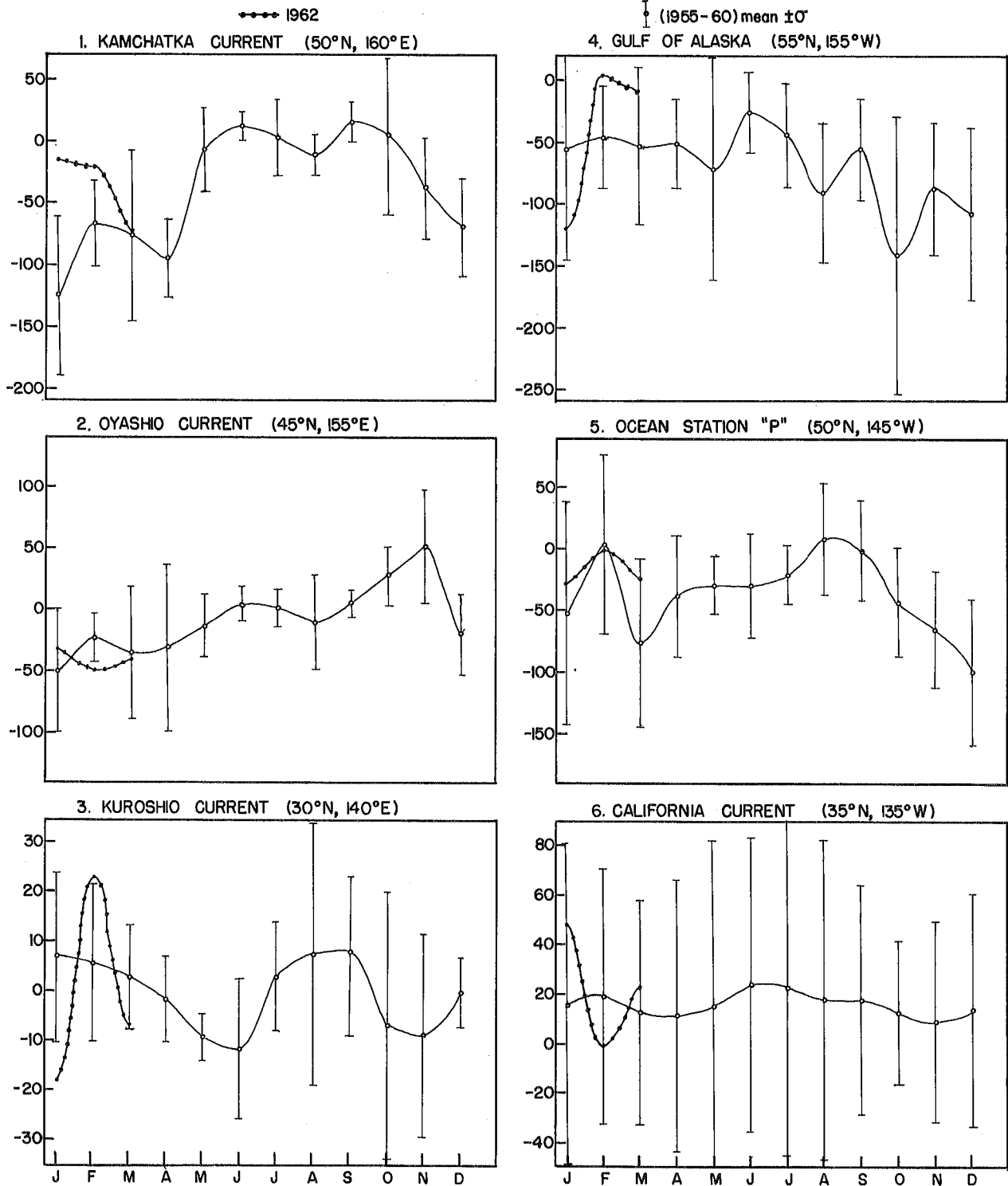

Figure 3

# INTEGRATED TOTAL TRANSPORT in millions of metric tons /second

●—● 1962

(1955-60) mean  $\pm$   $\sigma$

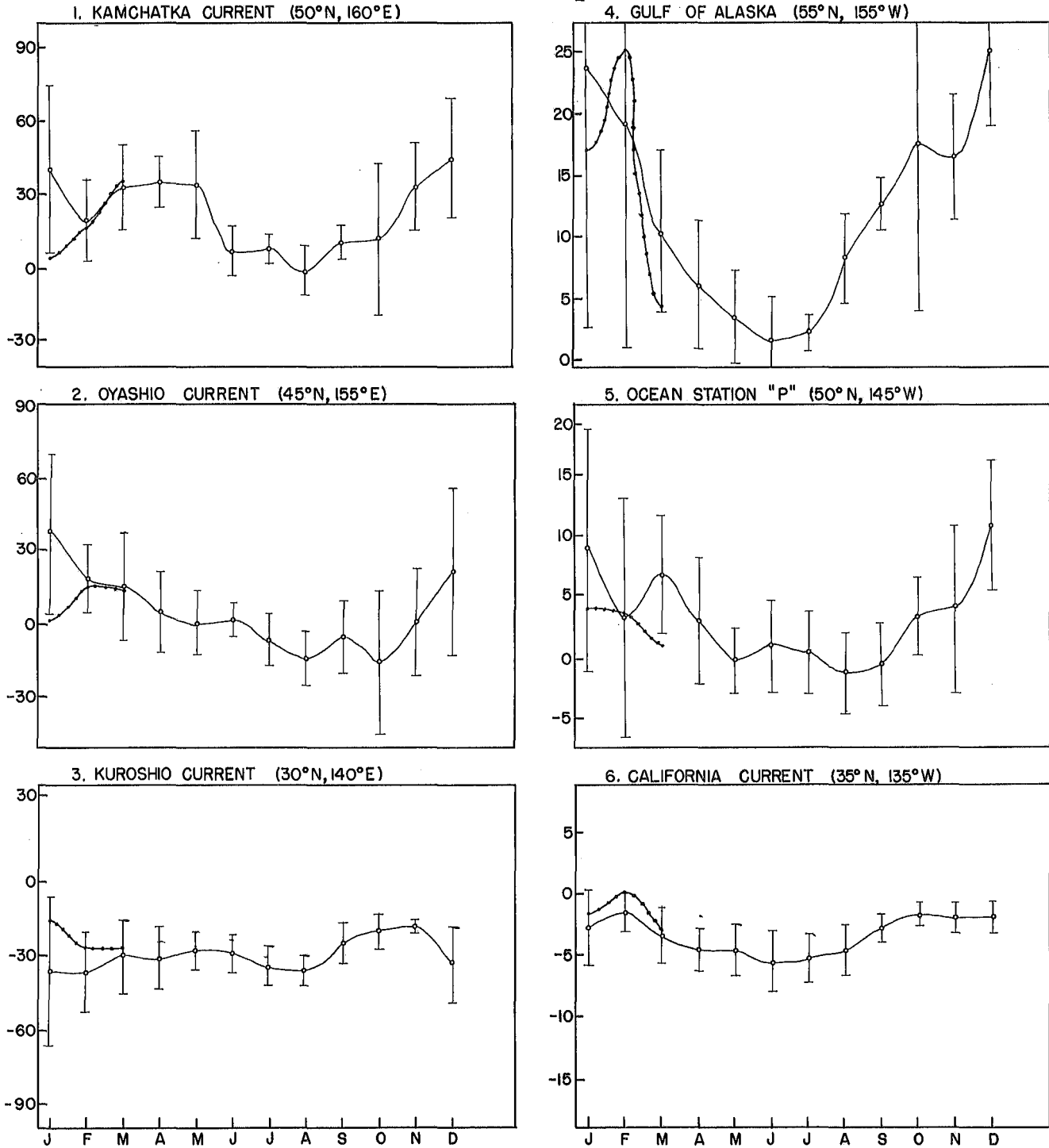

Figure 4

INTEGRATED GEOSTROPHIC TRANSPORT  
in millions of metric tons/second

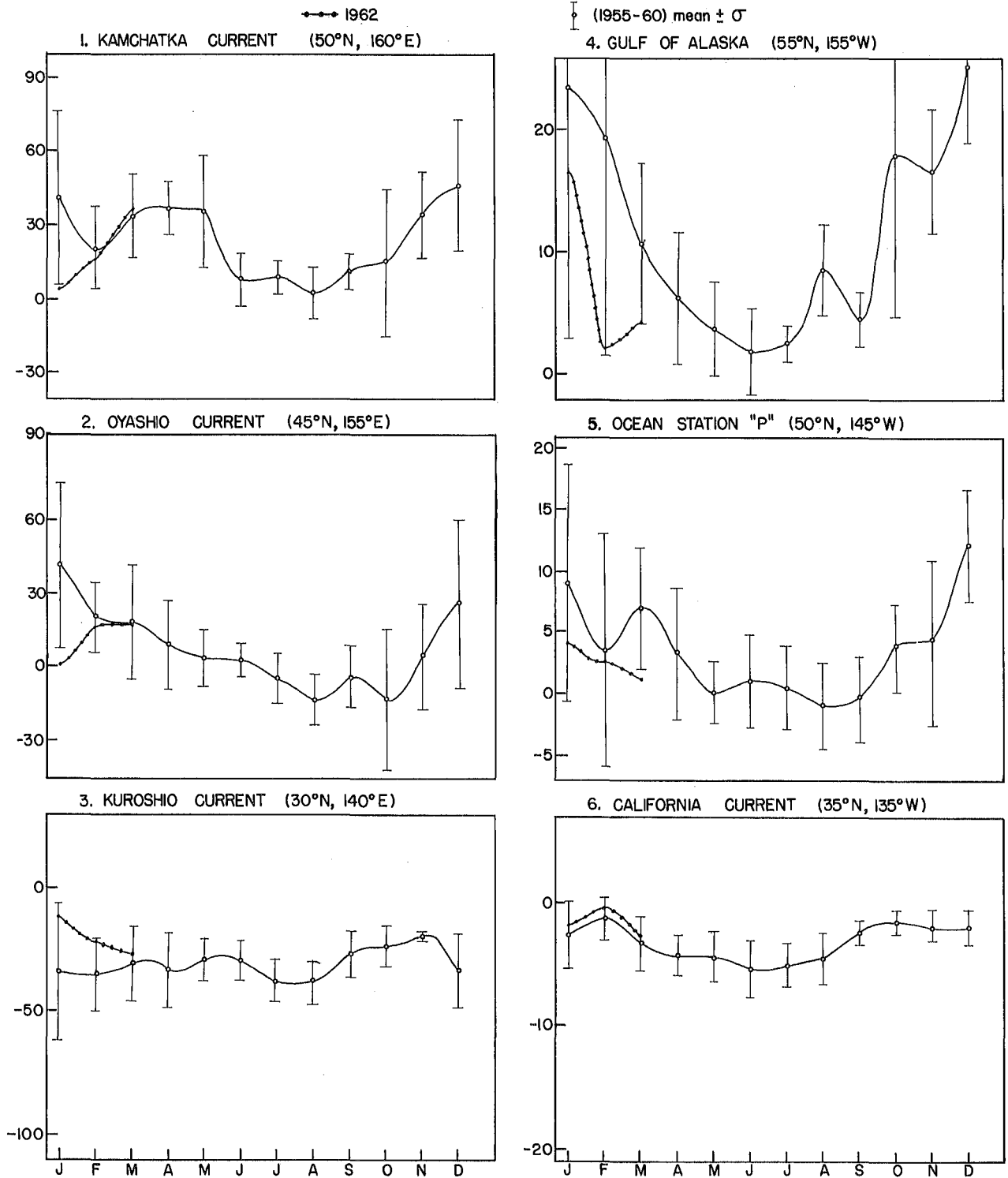

Figure 5

TREND OF INTEGRATED TOTAL TRANSPORT  
in millions of metric tons/second

—•— 1962

⌋ (1955-60) mean  $\pm \sigma$

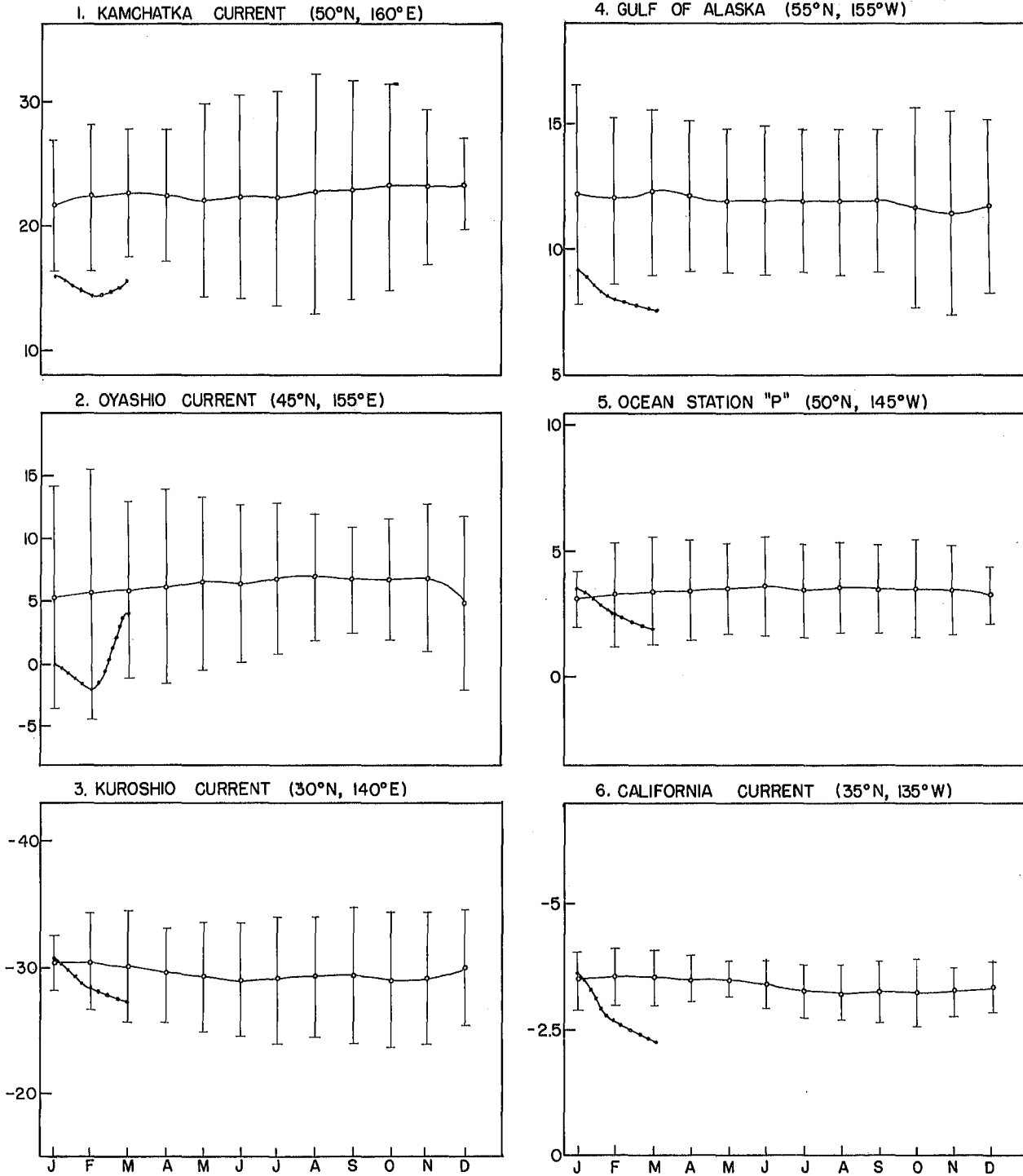

Figure 6

TREND OF INTEGRATED GEOSTROPHIC TRANSPORT  
in millions of metric tons /second

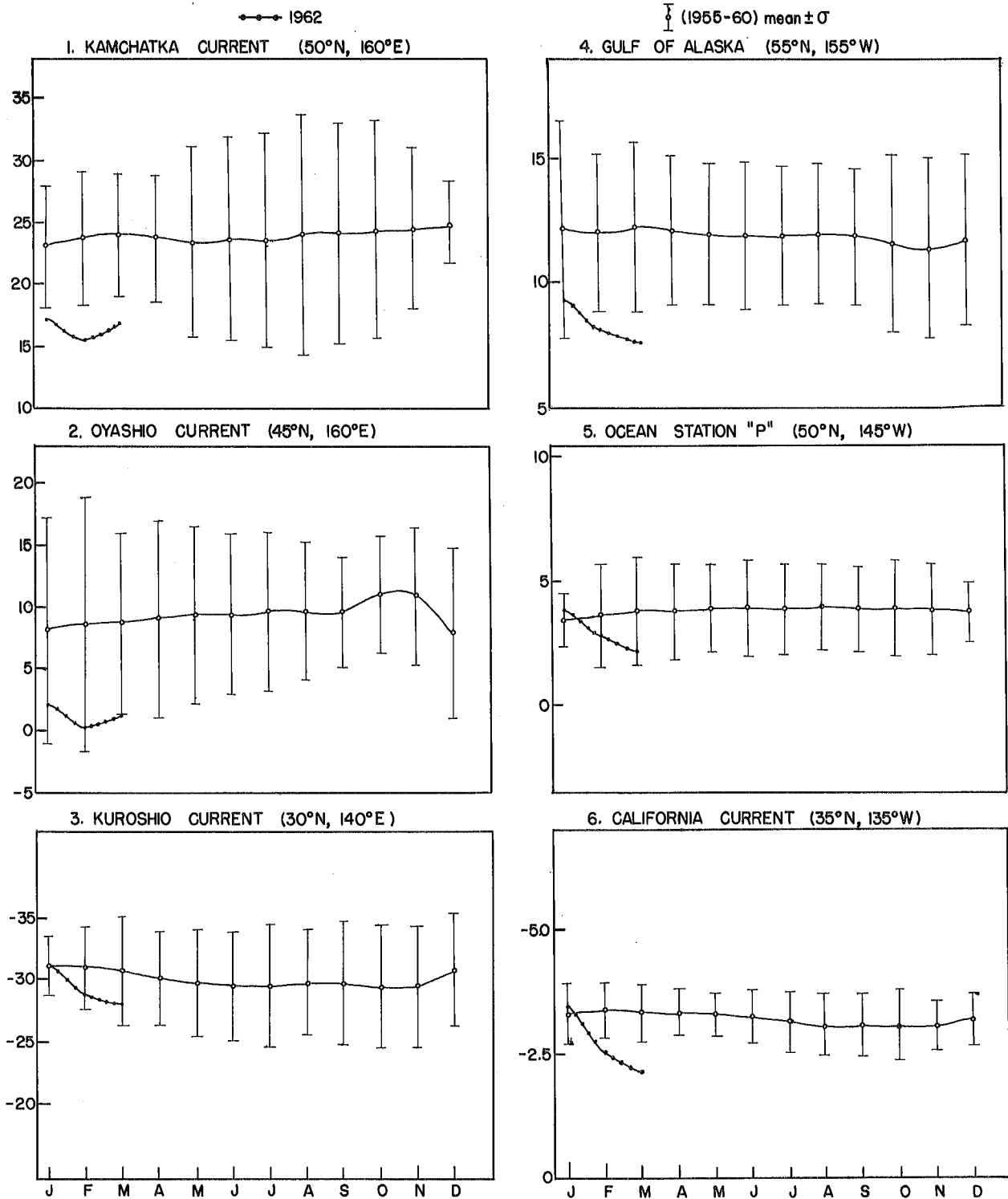

Figure 7

*H. Necker*

FISHERIES RESEARCH BOARD OF CANADA  
Pacific Oceanographic Group  
Nanaimo, B. C.

Circular 1962 - 15  
May 25, 1962

Oceanographic observations from Weathership  
C.M.S. "St. Catharines" Cruise P-62-1, February 27-April 16, 1962.

Oceanographic observations are made from C.M.S. "St. Catharines" through alternate six-week periods at Ocean Station "P" (Lat 50° N, Long 145° W) and en route to and from the station to monitor the oceanographic conditions in the eastern Subarctic Pacific Ocean. This program has been in operation since July 1956. A seven-week patrol, carrying one oceanographer, departed 27 February and returned 16 April. A comprehensive program of physical and biological observations was accomplished. This circular will deal, almost entirely, with temperature data.

Temperatures between "Swiftsure" and Ocean Station "P"

Figure 1 describes the geographical positions of oceanographic stations between "Swiftsure" and Ocean Station "P".

Temperatures obtained outbound between "Swiftsure" and Ocean Station "P" (28 February-2 March, Fig. 2) showed the usual maximum at station 1 and minimum at Station "P". This gradient was most evident in waters above 250 m depth. Below 250 m a secondary maximum occurred around station 3 due to a warm water intrusion below the thermocline. Waters at the surface and above 100 m depth had a cold water trough in the vicinity of station 4A and an area of fairly uniform temperature which included stations 5 and 6. Taylorgraph recordings (Fig. 7) of temperature at 3 m depth showed a series of sharp fluctuations about one half degree magnitude through this otherwise uniform area. Temperatures encountered in the surface isothermal layer at the Station "P" end of the line were of the order of 1.0 C° higher than might be expected after the winter cooling. A comparison of temperatures along the "S-P" line at this time and those of the same time period a year earlier (Fig. 6) shows a marked warming. In this comparison the warming at Station "P" was about 1.0 C° and as much as 1.5 C° between stations 6 and "P". The slight cooling that occurred in patches closer to the coast can be attributed to the relative positions of internal waves and/or water intrusions at the time the surveys were taken. Comparison of the temperatures along the line (28 February-2 March) with those obtained six weeks earlier (19-22 February, Fig. 4) also showed a slight warming at Station "P". The warming of deeper waters at station 3 indicates the aforementioned warm intrusion formed sometime during the six week period.

Temperatures obtained inbound along "P-S" (13-16 April, Fig. 3) show a further warming effect at Station "P" and vicinity (Fig. 5). The area around stations 5 and 6, previously described as having uniform

*Sumner*

temperature, cooled a small amount and Taylorgraph recordings of surface temperatures (3 m, Fig. 7) do not show any of the fluctuations present on the outbound line. The Taylorgraph also indicated the cold water trough at Station 4A had disappeared. The warm water intrusion previously noted at station 3 was no longer present. Lack of data for stations 4 and 4A prevents us from saying whether this intrusion had disappeared or merely moved seaward.

#### Temperatures at Ocean Station "P"

The monthly mean surface temperatures (Fig. 8) for the first three months of 1962 show a considerable warming between January and February but little further change through March. This warming places the February 1962 mean monthly temperature a full centigrade degree warmer than the February 1961 mean and about 0.5 C° above the ten-year mean, 1951-60. A further investigation of the temperatures at 10 m depth, read from bathythermograms taken during February, March and April of the years 1958 to 1962 inclusive (Fig. 9) demonstrates that these temperatures during 1962 are similar to those of 1958. The intermediate years of 1959, 1960, and 1961 had temperatures about 1.0 C° colder.

Reversing thermometer observations at Station "P" during the patrol showed a slight general warming above 75 m. Between the depths 100 and 200 m temperatures fluctuated considerably in association with a temperature inversion. This temperature inversion occurred from about 150 m depth to 200 m (Fig. 11) and was present throughout the patrol in some degree. A plot of temperatures at selected depths (Fig. 10) seems to indicate that the temperature inversion occurs at whatever depth the temperatures approached 4.5° C. Assuming that these temperature inversions occurred in the top of the halocline, it is possible that they were produced by an influx of colder water in the denser halocline. These temperature inversions were also evident at the seaward end of line "S-P" during both outbound and inbound transits.

Bathythermograms taken in the course of the regular daily program did not give any evidence of heating from the atmosphere. There were no transient thermoclines.

J.H. Meikle.

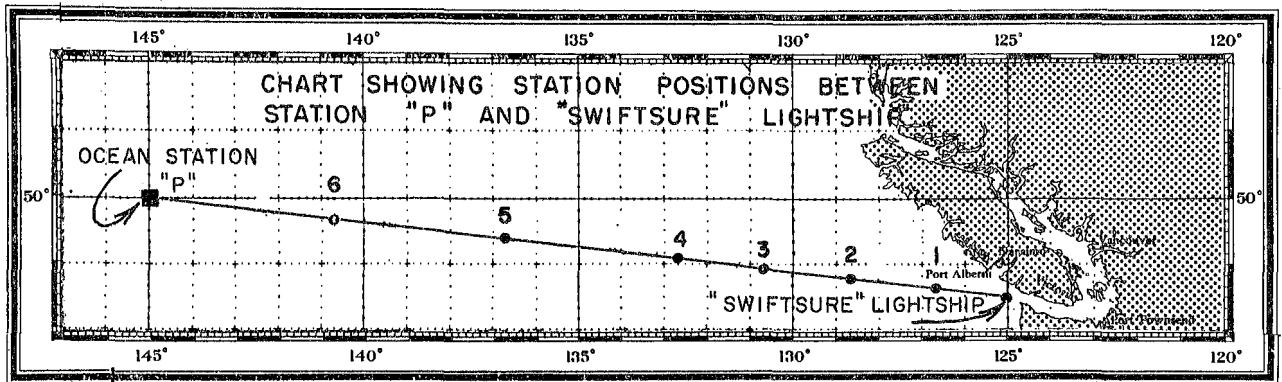

Figure 1.

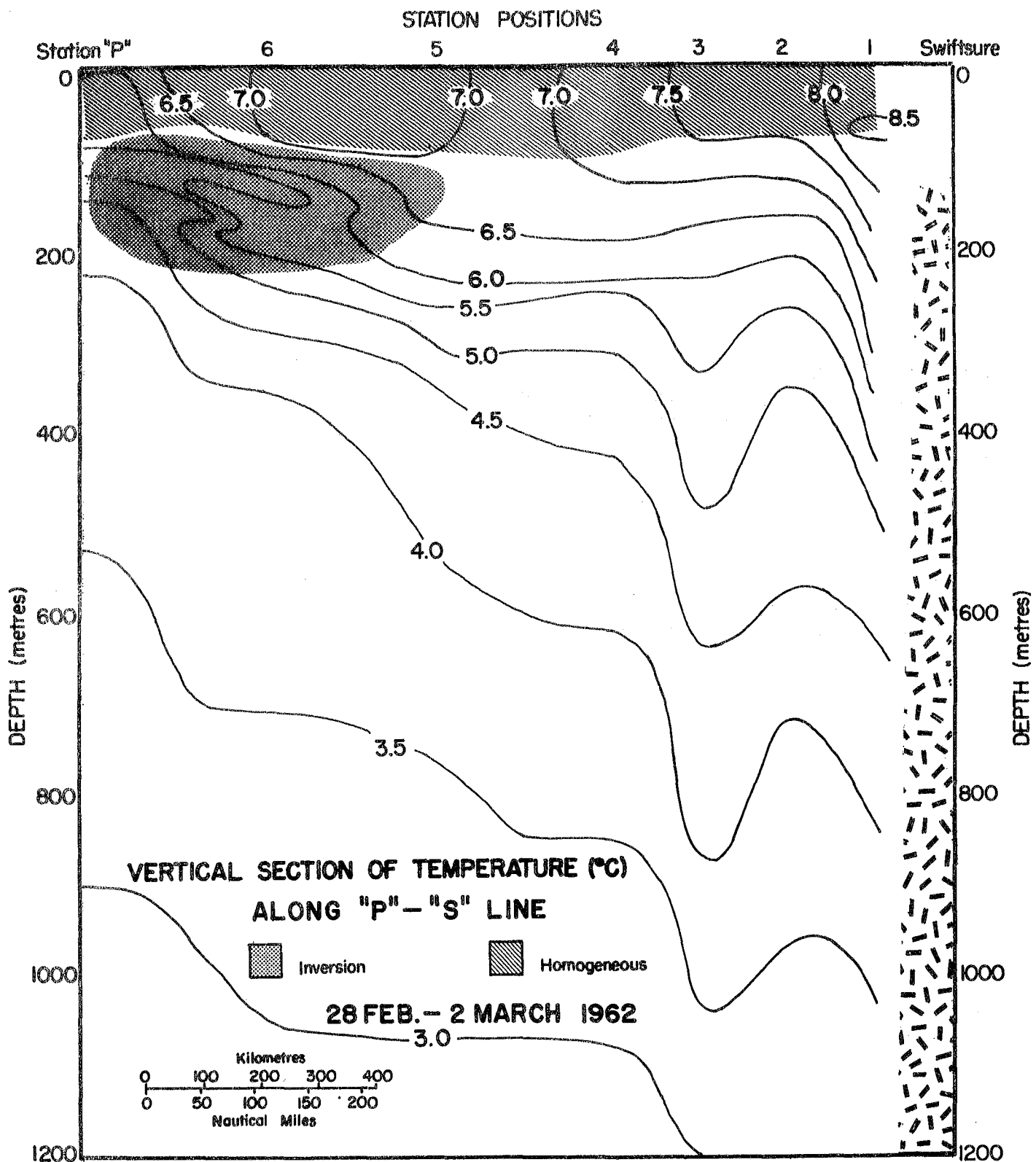

FIGURE 2

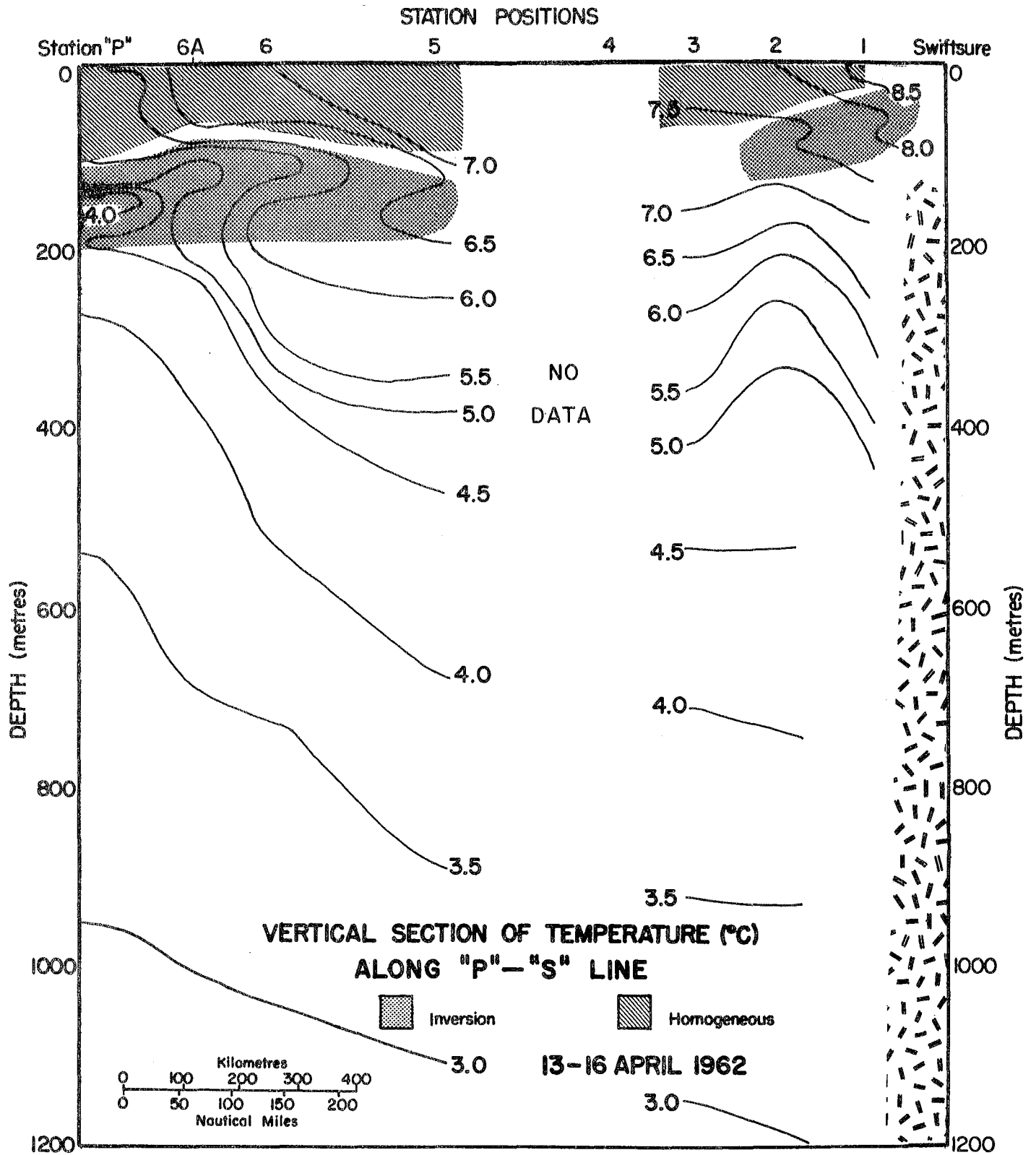
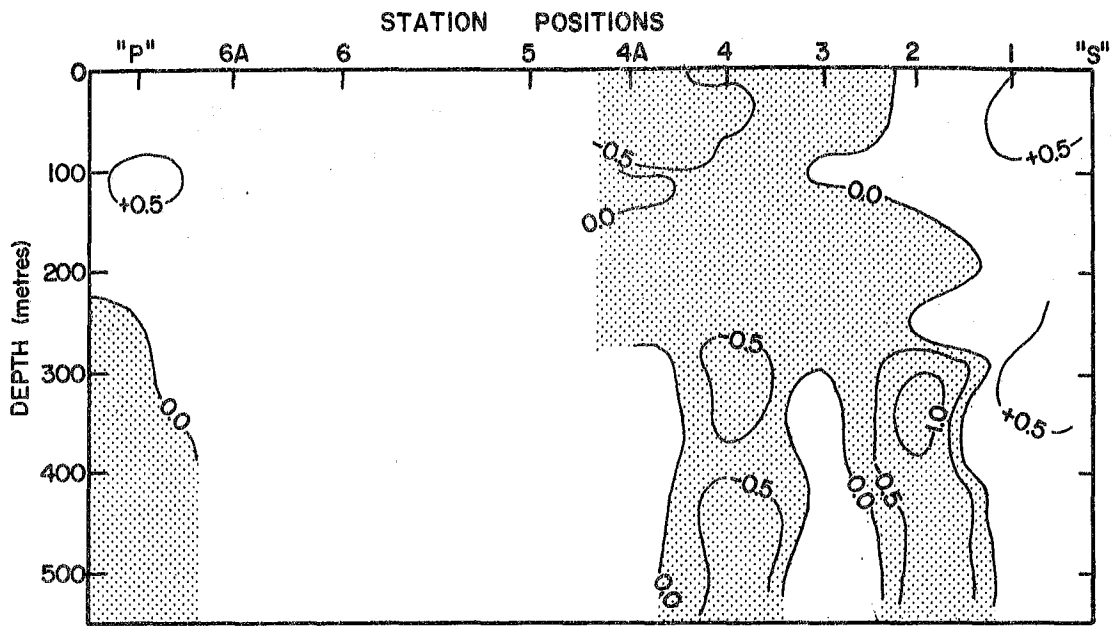

FIGURE 3



TEMPERATURE CHANGES (°C) BETWEEN STATION "P" AND SWIFTSURE

19-22 Feb. — 28 Feb.-2 March 1962

☒ Temperature decrease

FIGURE 4

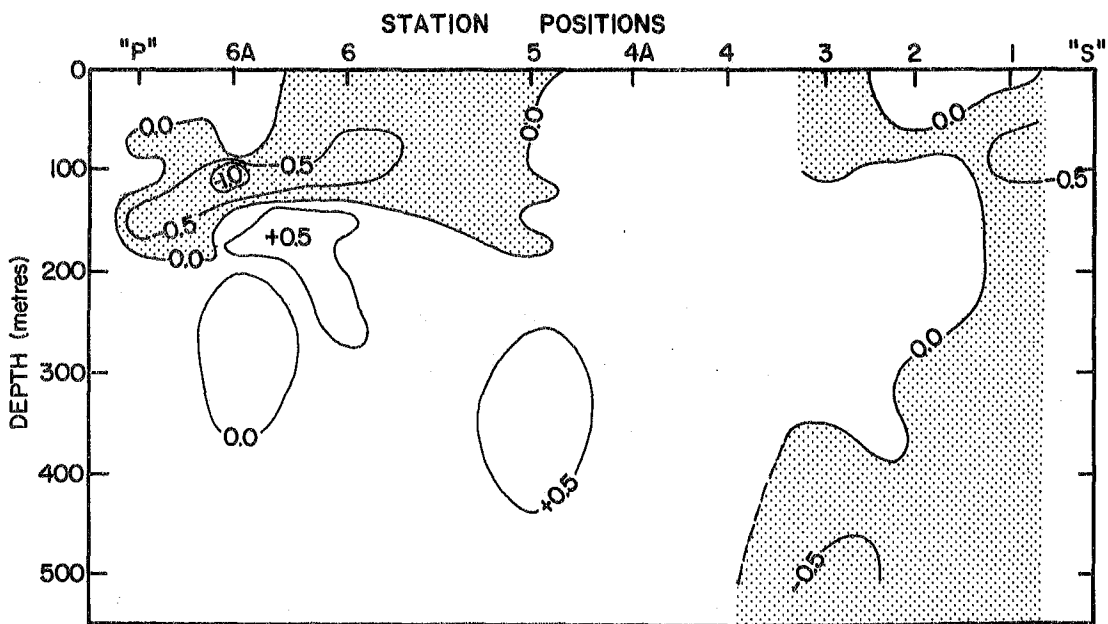

TEMPERATURE CHANGES (°C) BETWEEN STATION "P" AND SWIFTSURE

28 Feb.-2 March — 13-16 April 1962

☒ Temperature decrease

FIGURE 5

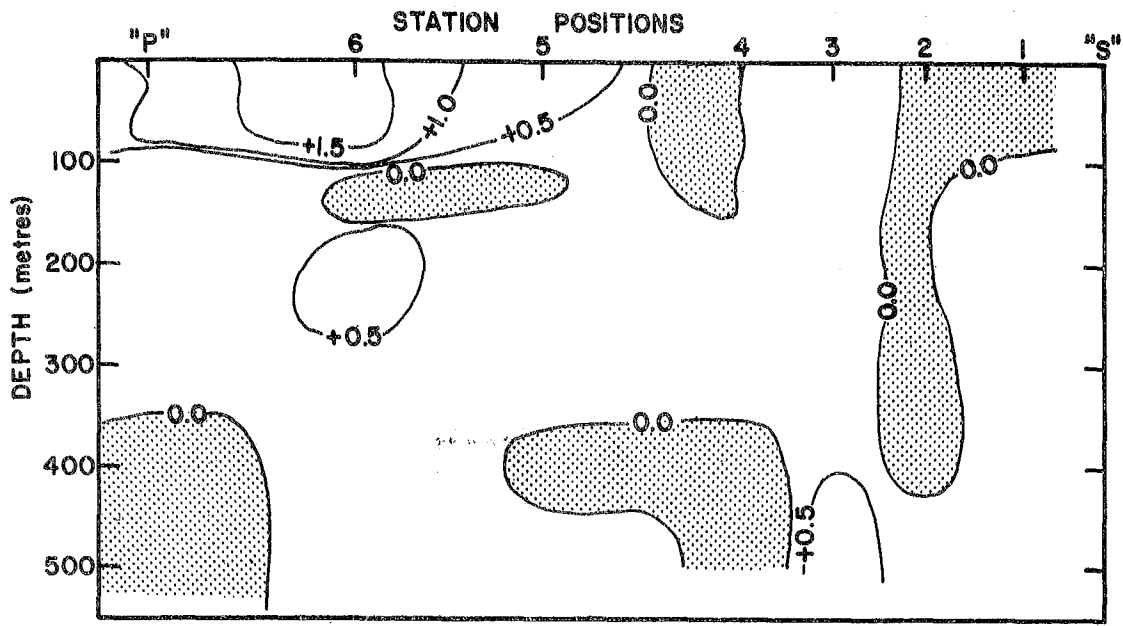

TEMPERATURE CHANGES (°C) BETWEEN STATION "P" AND SWIFTSURE

2-6 March 1961 ——— 28 Feb.-2 March 1962

☼ Temperature decrease

FIGURE 6

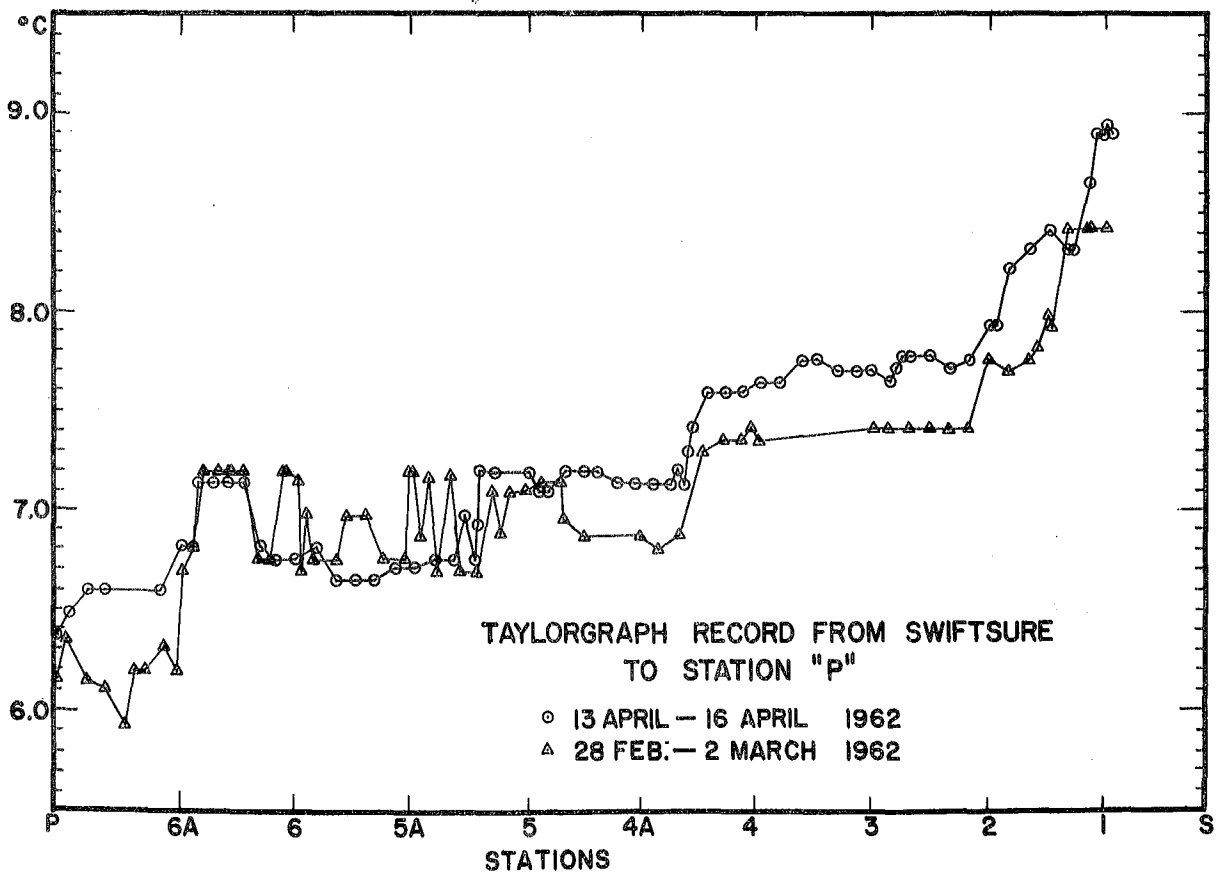

TAYLORGRAPH RECORD FROM SWIFTSURE TO STATION "P"

○ 13 APRIL - 16 APRIL 1962

△ 28 FEB. - 2 MARCH 1962

FIGURE 7

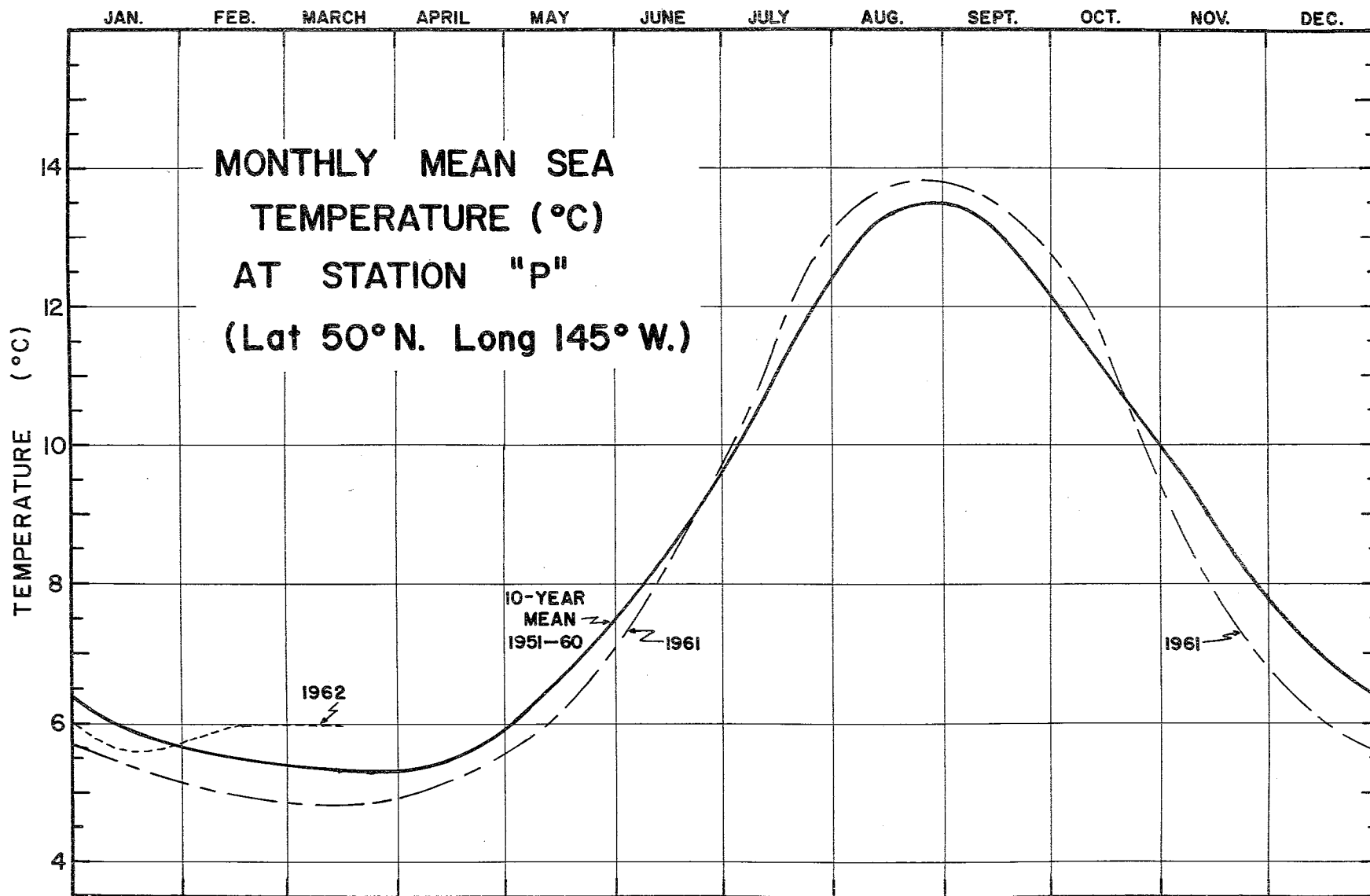
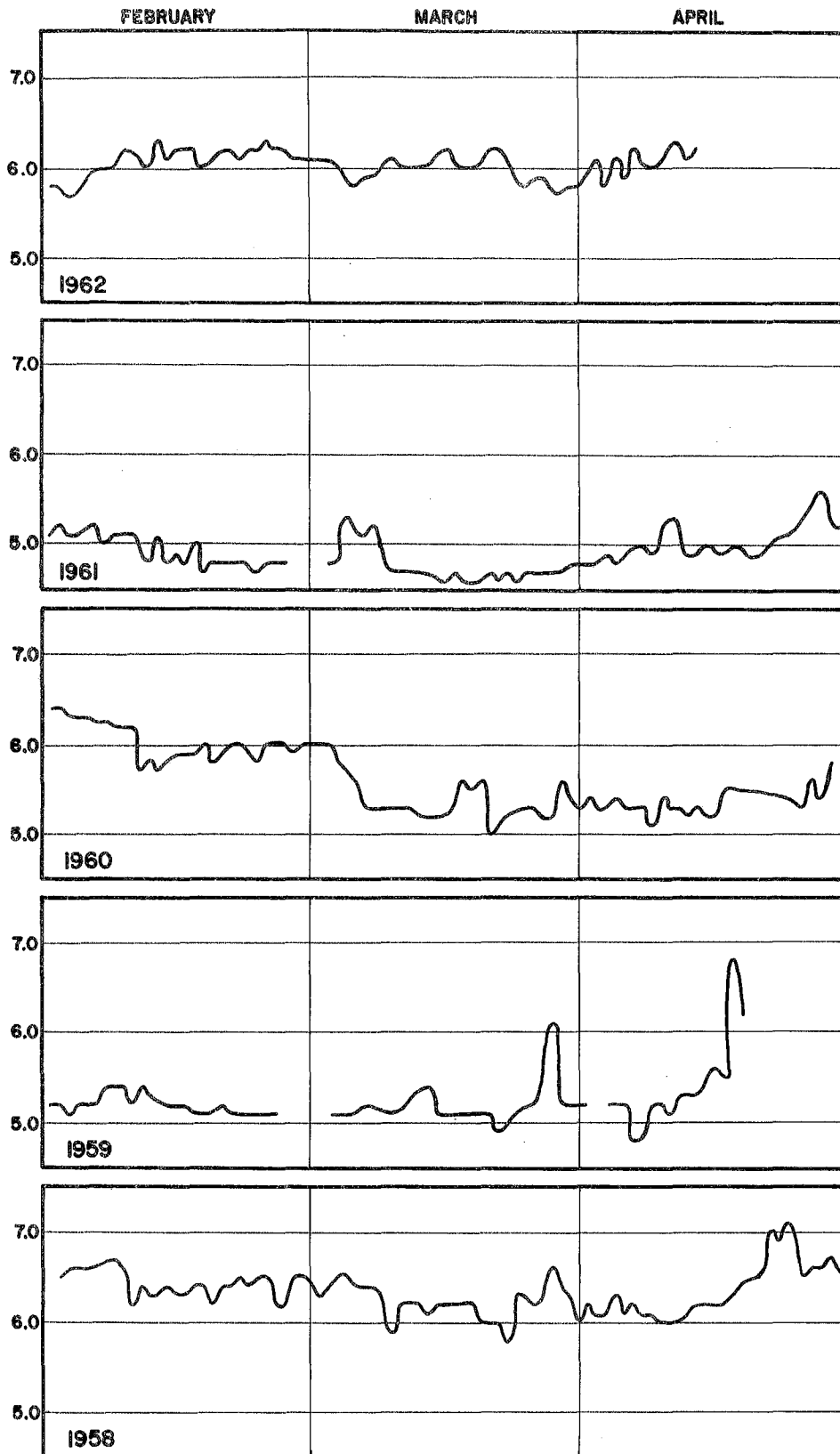
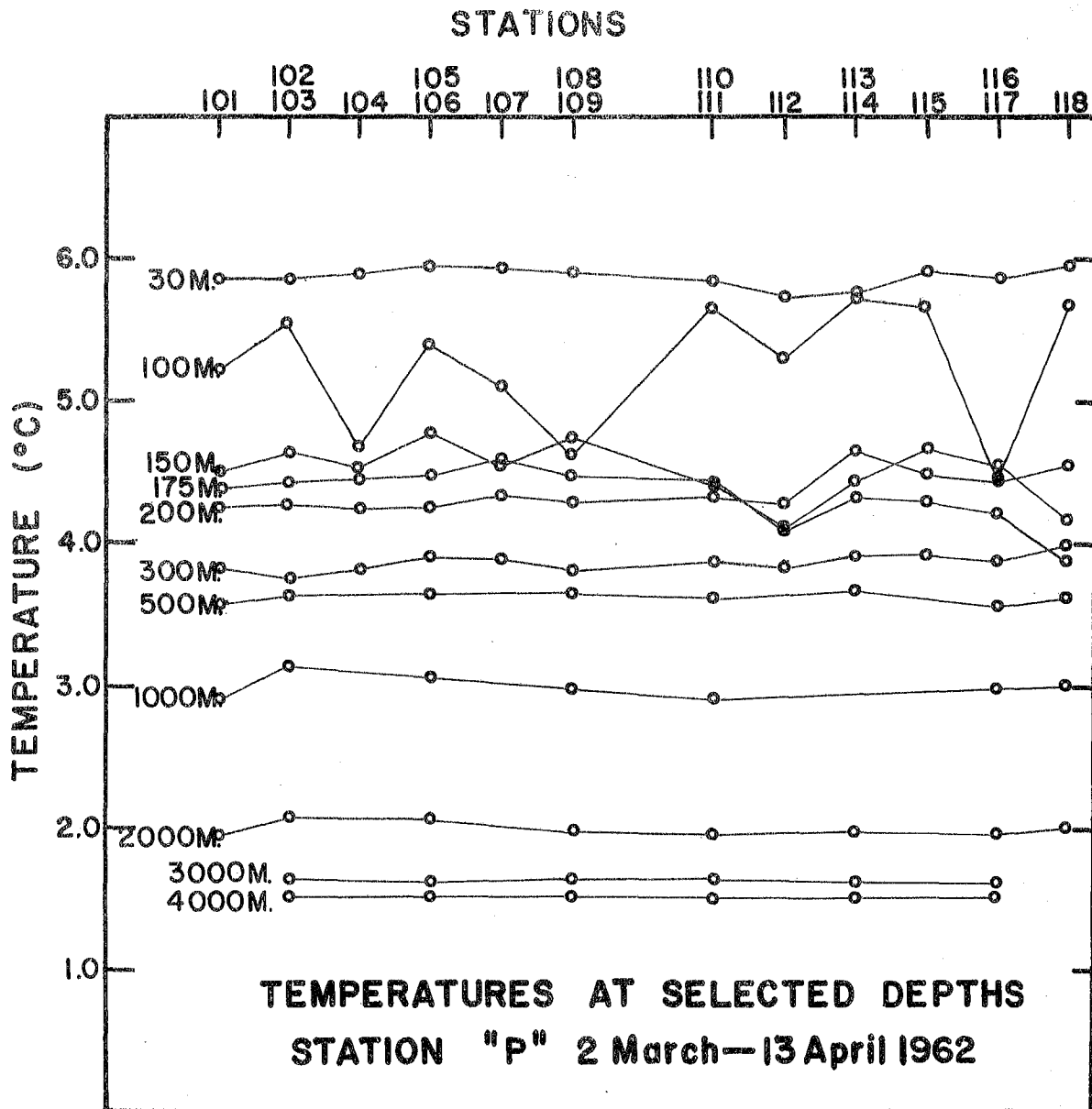

FIGURE 8



STATION "P" BATHY THERMOGRAPH TEMPERATURES  
 AT 10 METRES DEPTH

FIGURE 9



**FIGURE 10**

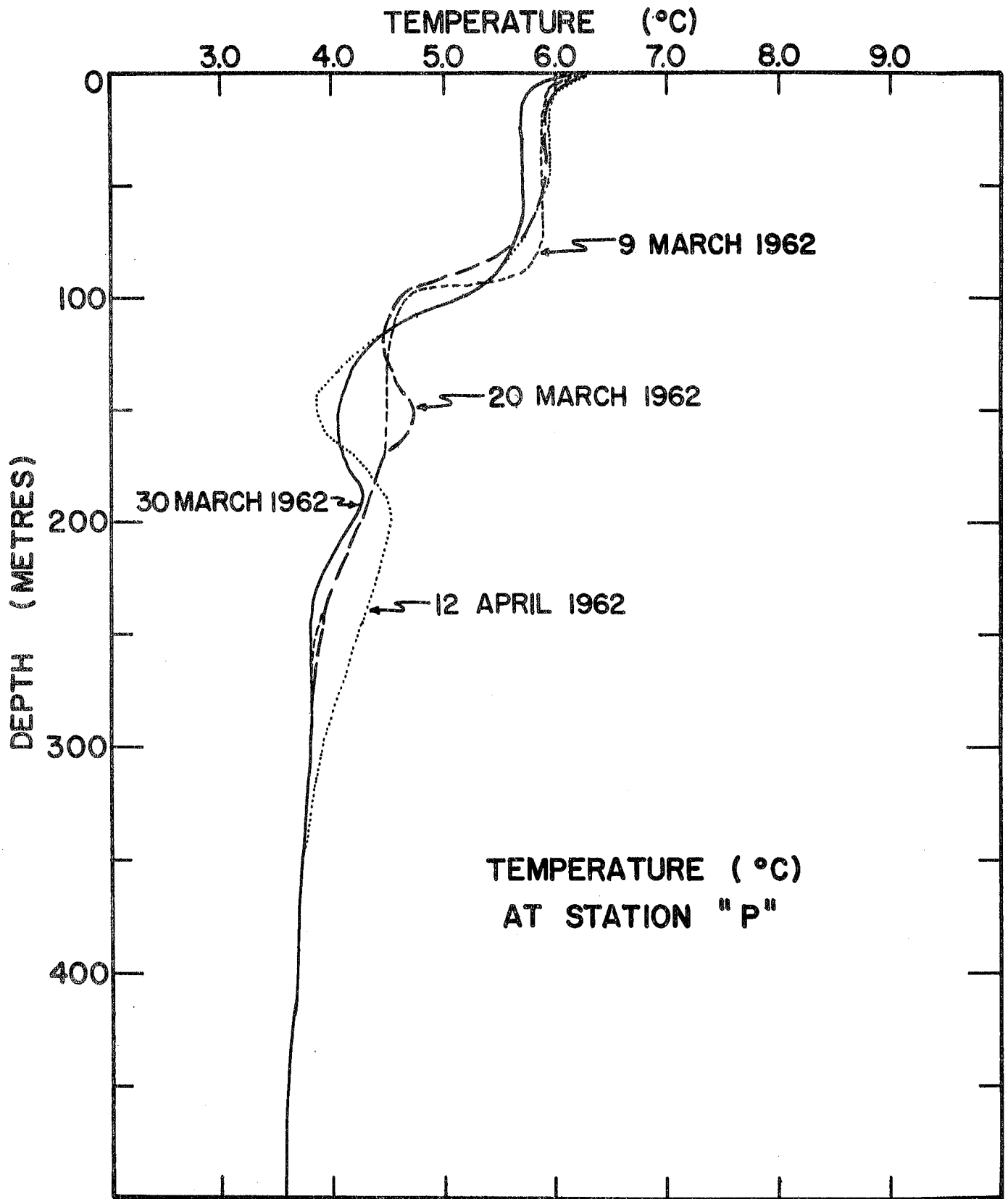

FIGURE II

FISHERIES RESEARCH BOARD OF CANADA  
 Pacific Oceanographic Group  
 Nanaimo, B. C.

Circular 1962 - 16  
 June 7, 1962

A Simplified Approximate Method for Manual Calculation of  
 Dynamic Height and Potential Energy Anomalies

Sometimes, in the course of plotting dynamic height and potential energy anomalies, an error in temperature or salinity is detected. It is often not expedient to await machine recomputation of the station and too laborious to recall the vanishing art of computing dynamic height and potential energy anomaly from hydrographic tables. A simple set of linear formulas has been devised to assist the oceanographer in these distressing circumstances.

Given the Northeastern Pacific Ocean, one can express the increment of dynamic height and potential energy anomalies from one standard depth to the next in the form

$$\Delta D_{z_{i+1}} - \Delta D_{z_i} = A_0 + a_i(T_i - T_0) - b_i(S_i - S_0) \\ + a_{i+1}(T_{i+1} - T_0) - b_{i+1}(S_{i+1} - S_0)$$

$$\chi_{i+1} - \chi_i = A'_0 + a'_i(T_i - T_0) - b'_i(S_i - S_0) \\ + a'_{i+1}(T_{i+1} - T_0) - b'_{i+1}(S_{i+1} - S_0)$$

where T and S denote temperature and salinity and the coefficients A, a and b are constant at each standard depth.

To use the formula, one needs to obtain values of temperature and salinity at the standard depth that are better suited to one's fancy, and to apply the formula to the depth intervals above and below the depth in question. The formula gives the increment which has to be added cumulatively starting with an acceptable value of dynamic height, i.e. the value at the

standard depth above the depth at which an error is noticed. The recalculated value for the next standard depth below the error will differ slightly from the original. This difference has to be subtracted from all succeeding standard depths. A similar procedure is followed for the potential energy anomaly.

The set of formulas yield quite acceptable results even for values of  $T-T_0$  of the order of  $2^{\circ}\text{C}$ .

N.P. Fofonoff

Calculation of Dynamic Height

$z_i - z_{i+1}$	$\Delta D_{i+1} - \Delta D_i$
250- 300	0.050 + 0.0025(T <sub>1</sub> - 3) - 0.0191(S <sub>1</sub> - 34) + 0.0025(T <sub>2</sub> - 3) - 0.0191(S <sub>2</sub> - 34)
300- 400	0.100 + 0.0050(T <sub>1</sub> - 3) - 0.0382(S <sub>1</sub> - 34) + 0.0051(T <sub>2</sub> - 3) - 0.0383(S <sub>2</sub> - 34)
400- 500	0.101 + 0.0051(T <sub>1</sub> - 3) - 0.0383(S <sub>1</sub> - 34) + 0.0052(T <sub>2</sub> - 3) - 0.0384(S <sub>2</sub> - 34)
500- 600	0.103 + 0.0052(T <sub>1</sub> - 3) - 0.0384(S <sub>1</sub> - 34) + 0.0053(T <sub>2</sub> - 3) - 0.0385(S <sub>2</sub> - 34)
600- 700	0.103 + 0.0053(T <sub>1</sub> - 3) - 0.0385(S <sub>1</sub> - 34) + 0.0054(T <sub>2</sub> - 3) - 0.0386(S <sub>2</sub> - 34)
700- 800	0.104 + 0.0054(T <sub>1</sub> - 3) - 0.0386(S <sub>1</sub> - 34) + 0.0054(T <sub>2</sub> - 3) - 0.0386(S <sub>2</sub> - 34)
800-1000	0.206 + 0.0107(T <sub>1</sub> - 3) - 0.0773(S <sub>1</sub> - 34) + 0.0115(T <sub>2</sub> - 3) - 0.0776(S <sub>2</sub> - 34)
1000-1200	0.187 + 0.0116(T <sub>1</sub> - 2) - 0.0777(S <sub>1</sub> - 34) + 0.0109(T <sub>2</sub> - 2) - 0.0785(S <sub>2</sub> - 34)
1200-1500	0.200 + 0.0164(T <sub>1</sub> - 2) - 0.1179(S <sub>1</sub> - 34) + 0.0175(T <sub>2</sub> - 2) - 0.1185(S <sub>2</sub> - 34)
1500-2000	0.494 + 0.0292(T <sub>1</sub> - 2) - 0.1979(S <sub>1</sub> - 34) + 0.0325(T <sub>2</sub> - 2) - 0.1997(S <sub>2</sub> - 34)
2000-2500	0.442 + 0.0326(T <sub>1</sub> - 1) - 0.2001(S <sub>1</sub> - 34) + 0.0321(T <sub>2</sub> - 1) - 0.2022(S <sub>2</sub> - 34)
2500-3000	0.452 + 0.0322(T <sub>1</sub> - 1) - 0.2026(S <sub>1</sub> - 34) + 0.0347(T <sub>2</sub> - 1) - 0.2044(S <sub>2</sub> - 34)
3000-3500	0.458 + 0.0348(T <sub>1</sub> - 1) - 0.2048(S <sub>1</sub> - 34) + 0.0373(T <sub>2</sub> - 1) - 0.2064(S <sub>2</sub> - 34)
3500-4000	0.465 + 0.0374(T <sub>1</sub> - 1) - 0.2068(S <sub>1</sub> - 34) + 0.0397(T <sub>2</sub> - 1) - 0.2086(S <sub>2</sub> - 34)

The formulas are arranged for use on a desk calculator with accumulative and negative multiplication keys. The subscript (1) refers to the temperature and salinity at the first standard depth ( $z_1$ ) and the subscript (2) to the temperature and salinity at the second standard depth ( $z_1 + 1$ ). The temperature ( $T_0$ ) is decreased with depth to keep the difference ( $T - T_0$ ) small.

## Potential Energy Calculation

$Z_i - Z_{i+1}$	$\chi_{i+1} - \chi_i$
250- 300	1.41 + 0.06(T <sub>1</sub> - 3) - 0.49(S <sub>1</sub> - 34) + 0.08(T <sub>2</sub> - 3) - 0.59(S <sub>2</sub> - 34)
300- 400	3.60 + 0.15(T <sub>1</sub> - 3) - 1.18(S <sub>1</sub> - 34) + 0.21(T <sub>2</sub> - 3) - 1.57(S <sub>2</sub> - 34)
400- 500	4.63 + 0.21(T <sub>1</sub> - 3) - 1.57(S <sub>1</sub> - 34) + 0.27(T <sub>2</sub> - 3) - 1.97(S <sub>2</sub> - 34)
500- 600	5.71 + 0.27(T <sub>1</sub> - 3) - 1.97(S <sub>1</sub> - 34) + 0.33(T <sub>2</sub> - 3) - 2.37(S <sub>2</sub> - 34)
600- 700	6.80 + 0.33(T <sub>1</sub> - 3) - 2.37(S <sub>1</sub> - 34) + 0.39(T <sub>2</sub> - 3) - 2.78(S <sub>2</sub> - 34)
700- 800	7.92 + 0.39(T <sub>1</sub> - 3) - 2.78(S <sub>1</sub> - 34) + 0.44(T <sub>2</sub> - 3) - 3.18(S <sub>2</sub> - 34)
800-1000	19.25 + 0.88(T <sub>1</sub> - 3) - 6.37(S <sub>1</sub> - 34) + 1.19(T <sub>2</sub> - 3) - 7.99(S <sub>2</sub> - 34)
1000-1200	21.39 + 1.19(T <sub>1</sub> - 2) - 8.00(S <sub>1</sub> - 34) + 1.35(T <sub>2</sub> - 2) - 9.71(S <sub>2</sub> - 34)
1200-1500	40.33 + 2.03(T <sub>1</sub> - 2) - 14.58(S <sub>1</sub> - 34) + 2.71(T <sub>2</sub> - 2) - 18.39(S <sub>2</sub> - 34)
1500-2000	89.52 + 4.52(T <sub>1</sub> - 2) - 30.60(S <sub>1</sub> - 34) + 6.71(T <sub>2</sub> - 2) - 41.22(S <sub>2</sub> - 34)
2000-2500	103.69 + 6.73(T <sub>1</sub> - 1) - 41.31(S <sub>1</sub> - 34) + 8.29(T <sub>2</sub> - 1) - 52.23(S <sub>2</sub> - 34)
2500-3000	130.12 + 8.31(T <sub>1</sub> - 1) - 52.35(S <sub>1</sub> - 34) + 10.77(T <sub>2</sub> - 1) - 63.44(S <sub>2</sub> - 34)
3000-3500	156.82 + 10.80(T <sub>1</sub> - 1) - 63.58(S <sub>1</sub> - 34) + 13.54(T <sub>2</sub> - 1) - 74.82(S <sub>2</sub> - 34)
3500-4000	184.70 + 13.57(T <sub>1</sub> - 1) - 74.98(S <sub>1</sub> - 34) + 16.48(T <sub>2</sub> - 1) - 86.53(S <sub>2</sub> - 34)

The formulas are arranged for use on a desk calculator with accumulative and negative multiplication keys. The subscript (1) refers to the temperature and salinity at the first standard depth ( $Z_1$ ) and the subscript (2) to the temperature and salinity at the second standard depth ( $Z_{i+1}$ ). The temperature ( $T_0$ ) is decreased with depth to keep the difference ( $T - T_0$ ) small.

*H. Neidler*

FISHERIES RESEARCH BOARD OF CANADA  
Pacific Oceanographic Group  
Nanaimo, B.C.

Circular 1962 - 17  
June 7, 1962

Surface Sea Water Temperature and Changes of Sea Temperature  
between Swiftsure and Ocean Station "P", 11-15/IV/62 and  
23-27/V/62

This report is based on Taylorgraph recorded surface temperatures from the C.C.G.S. "Stonetown" and temperatures observed from C.C.G.S. "St. Catharines" between Station "P" and Swiftsure Bank (Fig. 1) during the periods April 11 - 16 and May 23-27, 1962. The C.C.G.S. "St. Catharines" data was radioed by C.D. McAllister on May 29, 1962.

The temperature changes that occurred from 100 m to 300 m depth between mid-April and the end of May are shown in Figure 2. Cooling was predominant in the section with particularly strong cooling occurring at Station 6. The only significant amount of warming occurred at Station 2.

The surface temperatures recorded by the Taylorgraph on the C.C.G.S. "Stonetown" between Station "P" and Swiftsure during mid-April and the end of May are illustrated in Figure 3. The 10 metre temperatures obtained by the C.C.G.S. "St. Catharines" at the end of May are also included in the same diagram. It can be seen that the temperature near the surface had increased about 1 C° at Station "P" and had increased progressively towards the coast during the C.C.G.S. "Stonetown" patrol. Near Swiftsure Bank the water near the surface had warmed about 2.5 C°.

The 10 metre temperature sent in from C.C.G.S. "St. Catharines" were obtained up to four days earlier than the inbound C.C.G.S. "Stonetown" Taylorgraph temperatures and are at least seven metres deeper. The differences in time, depth, and latitudinal position will account for the minor temperature differences.

D.G. Robertson

*[Handwritten signature]*

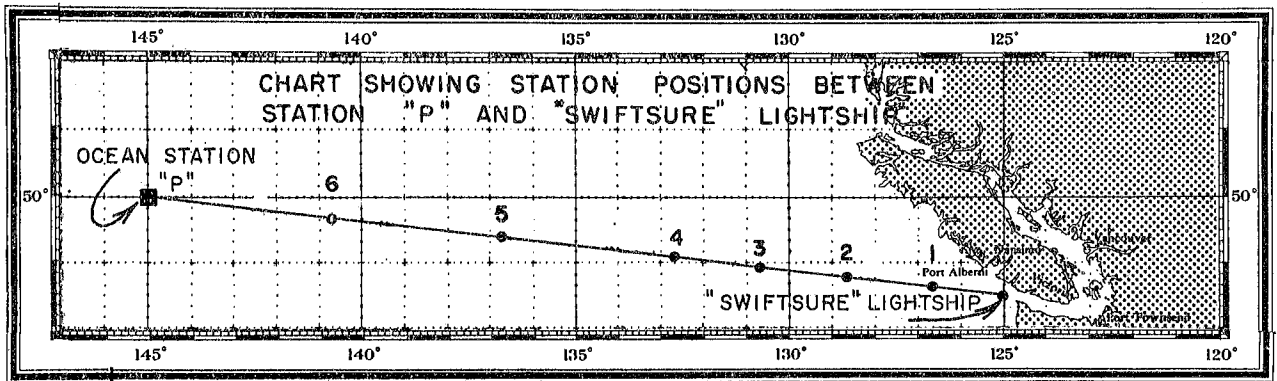

Figure 1.

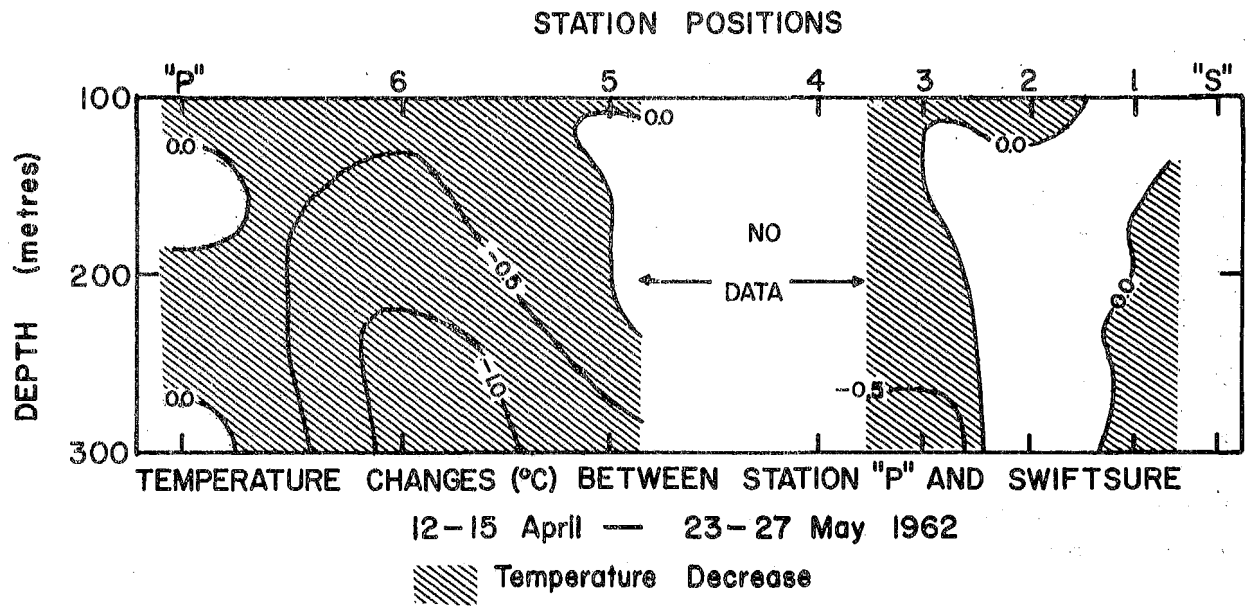

Figure 2.

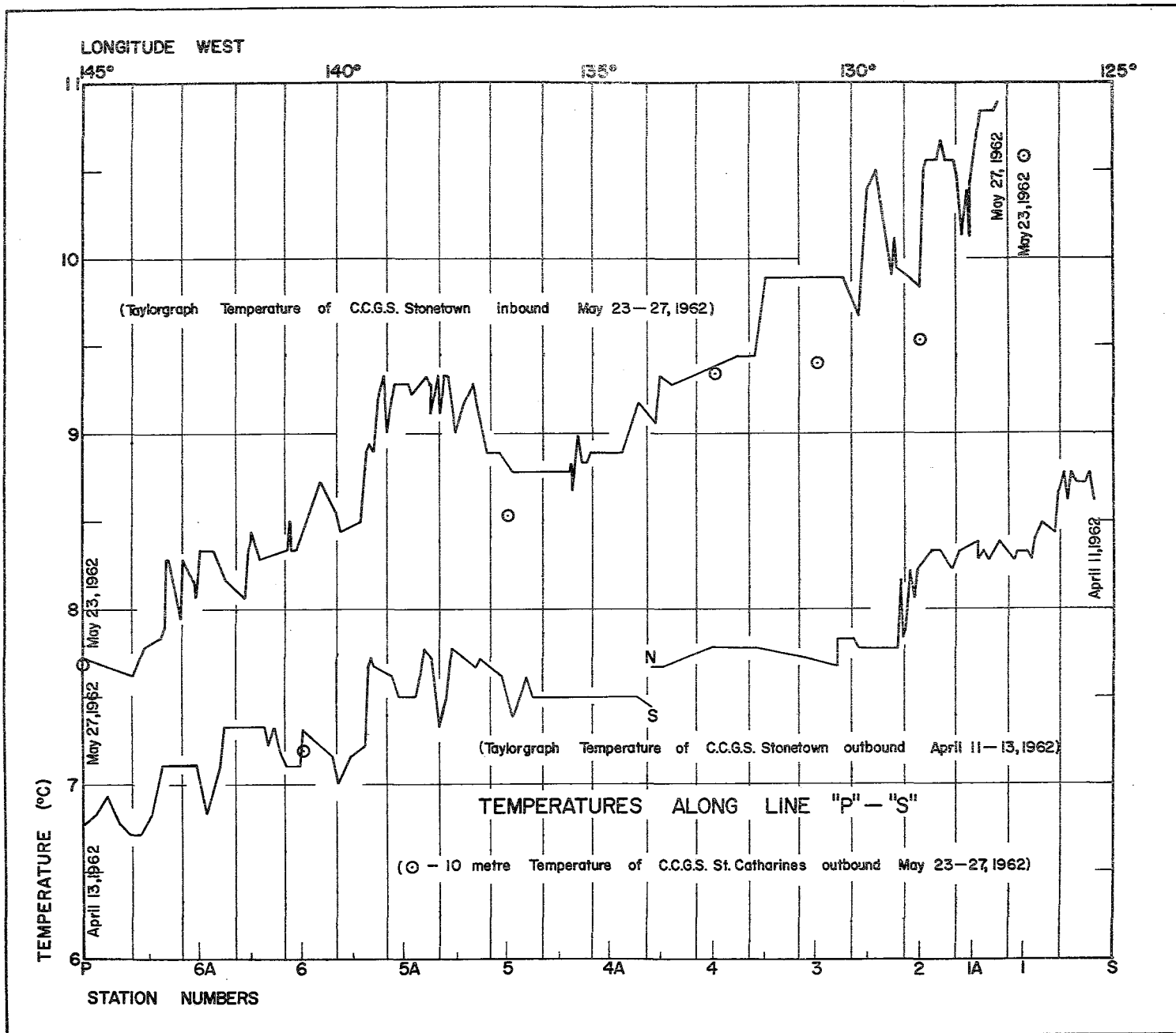

Figure 3.

*H. Munier*

FISHERIES RESEARCH BOARD OF CANADA  
Pacific Oceanographic Group  
Nanaimo, B. C.

Circular 1962 - 18  
July 17, 1962

Transport calculations for the North Pacific Ocean  
April and May 1962

Sverdrup (1947), Stommel (1948), and Munk (1950) have shown that the total steady-state transport of mass in the ocean depends primarily on the curl of the wind stress components acting on the surface of the ocean. Calculations have been performed to estimate the wind stress over the surface of the ocean by computing mean geostrophic winds from pressure differences between grid points, applying a transformation to estimate surface winds, and using a "square law" formula to relate wind speeds to surface stresses (Fofonoff, MS 1960, 1961). The purpose of these calculations is two-fold. First, to find out how long an averaging period is necessary to approach steady-state conditions and second, to gain some idea of the variability, both with latitude and time, of the transport that is imposed on the ocean by the atmosphere.

Detailed descriptions of the method used for evaluating the transports are given in the introduction to the annual volumes of transport computations (Fofonoff, MS 1960, 1961). The actual computer program for the calculation of mass transport is contained in the program manual M-1 (Fofonoff and Froese, MS 1960).

Six grid points in regions of special interest have been selected to evaluate the transport components for a given month in terms of mean values. They lie in the Gulf of Alaska (55° N, 155° W), Ocean Station "P" (average values at 50° N, 150° W and 50° N, 140° W), west of California Current (35° N, 135° W), adjacent to the Kuroshio Current (30° N, 160° E), the Oyashio Current (45° N, 155° E), and the Kamchatka Current (50° N, 160° E).

At each grid point the mean values and the standard deviations of the transport components from values for the same month from previous years are given in tabular form. In addition, the mean values of the integrated total and geostrophic transport for the month and eleven preceding months are given and compared with similar averages in previous years to indicate the long term trend of computed transport.

The departures of the monthly values from their means have been divided into three classes in terms of the number of standard deviations from the mean. The classes are:

Class 1: departure of less than one standard deviation from the mean (68% of values for a Gaussian distribution). Values falling in this range are termed "normal".

Class 2: departures of one to two standard deviations from the mean (17% of values for a Gaussian distribution). These values will be referred to as "abnormal".

*For back -  
Orrin*

Class 3: departures greater than two standard deviations from the mean (5% of values for a Gaussian distribution). Values whose variation falls in this range will be denoted as "extreme".

### Transport charts

- I. Monthly mean sea-level atmospheric pressure given as the anomaly of mean atmospheric pressure from 1000 mbs. in units of 1/10 millibars.
- II. Meridional component of Ekman transport ( $V_E$ ) in units of 10 metric tons/km/sec.
- III. Zonal component of Ekman transport ( $U_E$ ) in units of 10 metric tons/km/sec.
- IV. Meridional component of total transport ( $V$ ) in units of 100 metric tons/km/sec.

The values shown on chart IV are  $-V$ .

- V. Integrated total transport ( $\Psi$ ) in units of 100,000 metric tons/sec.
- VI. Integrated geostrophic transport ( $\Psi_g$ ) in units of 100,000 metric tons/sec.

The convention of signs adopted is that northward and eastward transport shall be considered as positive and southward and westward flow shall be negative.

### References

- Fofonoff, N.P. MS, 1960. Transport computations for the North Pacific Ocean 1955-58. Fish. Res. Bd. Canada, MS Rept., Oceanogr. and Limnol. Series, Nos. 77-80, 93 pp.
- MS, 1961. Transport computations for the North Pacific Ocean 1959. Fish. Res. Bd. Canada, MS Rept., Oceanogr. and Limnol. Series, No. 85, 181 pp.
- Fofonoff, N.P., and C. Froese. MS, 1960. Programs for oceanographic computations and data processing on the electronic digital computer ALWAC III-E. M-1 miscellaneous programs. Fish. Res. Bd. Canada, MS Rept., Oceanogr. and Limnol. Series, No. 72, 35 pp.
- Munk, W.H. 1950. On the wind-driven ocean circulation. J. Meteorol. 1 (2), 79-93.
- Stommel, H. 1948. The westward intensification of wind-driven ocean currents. Trans. Amer. Geophys. Union 29, (2): 202-206.
- Sverdrup, H.V. 1947. Wind-driven currents in a baroclinic ocean; with applications to the equatorial currents of the Eastern Pacific. Proc. Nat. Acad. Sc., 33 (11): 318-326.

NOTE: This circular is the last in the series of transport calculations for the North Pacific Ocean. No further transport calculations will be made at Pacific Oceanographic Group for the present.

Assessment of Transport Calculations for April 1962

The month of April 1962 shows a high incidence of 'abnormal' and 'extreme' values of all transport components. At the grid points on the western side, the meridional component of Ekman transport shows a marked change towards the north, the values all being more positive, and the departure from the mean lying in the 'extreme' range. On eastern side the values of this component are normal. The zonal component of Ekman transport shows an extreme increase to the east in the Kamchatka Current, an extreme increase to the west in the Gulf of Alaska, remains near normal in the Oyashio Current and at Ocean Station "P", and shows abnormal changes to the west and east in the Kuroshio and California Currents respectively. The trends of total and geostrophic transport are less in absolute value at all grid points except that for the Kuroshio Current. In most cases, the departures from the mean were similar in magnitude and direction to those for the month of April 1961.

Assessment of Transport Calculations for May 1962.

Again, this month was characterized by the large number of extreme and abnormal values of transport components. The meridional component of Ekman transport remained 'extreme' in the Gulf of Alaska, deviating in a southerly direction from the mean value. The departure from the mean of the meridional component of total transport at Ocean Station "P" was in the extreme range, the deviation taking place in a northerly direction. The trends of integrated total and geostrophic transport were all less in absolute value than the mean, the departure being abnormal or extreme for all grid points except <sup>for</sup> that at Station "P".  
^

F.M. Boyce.

Table 1: A comparison of transport components at selected grid points with the average values for the same month from previous years.

1. Kamchatka Current (50° N, 160° E)						4. Gulf of Alaska (55° N, 155° W)					
Apr 1962	Apr 1961	Apr Mean (55-60)	$\sigma$	$\frac{ x-\bar{x} }{\sigma}$	Class	Apr 1962	Apr 1961	Apr Mean (55-60)	$\sigma$	$\frac{ x-\bar{x} }{\sigma}$	Class
$V_E$ -2	-30	-27.9	11.9	2.35	3	$V_E$ -20	-17	-11.0	15.2	0.59	1
$U_E$ 48	32	9.4	15.7	2.45	3	$U_E$ -40	-2	1.7	11.1	3.76	3
$-V$ 10	-84	-95.3	30.7	3.43	3	$-V$ -178	-70	-51.0	36.3	3.50	3
$\Psi$ 42	46	307.0	148	1.79	2	$\Psi$ 95	80	65.0	47.8	0.63	1
$\Psi_1$ 58	63	326.3	151	1.78	2	$\Psi_1$ 96	82	66.0	48.8	0.61	1
$\Psi_2$ 155.1	247.3	227.9	47.7	1.53	2	$\Psi_2$ 76.5	99.3	117.7	28.2	1.46	2
$\Psi_3$ 168.8	277.6	244.3	47.3	1.60	2	$\Psi_3$ 77.2	98.7	117.3	28.1	1.43	2

2. Oyashio Current (45° N, 155° E)						5. Ocean Station "P" (50° N, 145° W)					
Apr 1962	Apr 1961	Apr Mean (55-60)	$\sigma$	$\frac{ x-\bar{x} }{\sigma}$	Class	Apr 1962	Apr 1961	Apr Mean (55-60)	$\sigma$	$\frac{ x-\bar{x} }{\sigma}$	Class
$V_E$ -4	-55	-57.4	12.4	4.31	3	$V_E$ 36	-37	-36.9	30.6	0.03	1
$U_E$ 31	48	29.3	20.6	0.08	1	$U_E$ 7	8	17.6	9.0	1.17	2
$-V$ -3	-56	-31.7	66.7	0.43	1	$-V$ -73	8	-37.3	47.4	0.75	1
$\Psi$ -137	-450	20.0	176	0.89	1	$\Psi$ 66	-5.0	25.7	48.5	0.83	1
$\Psi_1$ -122	-129	62.3	186	0.99	1	$\Psi_1$ 68	-1	29.0	50.0	0.78	1
$\Psi_2$ -38.8	77.5	63.7	68.8	1.49	2	$\Psi_2$ 25.6	53.8	38.0	19.3	0.64	1
$\Psi_3$ -19.2	105.4	92.7	70.2	1.59	2	$\Psi_3$ 27.8	60.7	41.5	19.5	0.70	1

3. Kuroshio Current (30° N, 140° E)						6. California Current (35° N, 135° W)					
Apr 1962	Apr 1961	Apr Mean (55-60)	$\sigma$	$\frac{ x-\bar{x} }{\sigma}$	Class	Apr 1962	Apr 1961	Apr Mean (55-60)	$\sigma$	$\frac{ x-\bar{x} }{\sigma}$	Class
$V_E$ 8	4	0.7	3.4	2.15	3	$V_E$ -14	-3	-16	16.7	0.12	1
$U_E$ 0	5	5.4	3.6	1.50	2	$U_E$ 1	-14	-11.0	7.4	1.35	2
$-V$ 8	-2	-1.5	8.7	1.09	2	$-V$ 46	37	11.2	54.8	0.64	1
$\Psi$ -154	-350	-323.9	122	1.39	2	$\Psi$ -53	-30	-42.4	52.1	0.20	1
$\Psi_1$ -173	-369	-336.6	138	1.18	2	$\Psi_1$ -51	-28	-39.7	15.8	0.72	1
$\Psi_2$ -256.8	-339.4	-157.6	37.3	2.82	3	$\Psi_2$ -24.4	-38.2	-35.4	4.7	2.34	3
$\Psi_3$ -263.2	-338.4	-306.9	36.2	1.21	2	$\Psi_3$ -23.3	-36.2	-33.5	4.5	2.27	3

Explanation of table:

$\sigma$  is based on (55-60) values

$\frac{|x-\bar{x}|}{\sigma}$  denotes deviation from mean in terms of standard deviation

$\Psi, \Psi_1, \Psi_2, \Psi_3$  are trends of integrated transports based on the straight mean of the month and the eleven preceding months

Classes are explained on pages 1-2.

Table 2: A comparison of transport components at selected grid points with average values for the same month from previous years.

1. Kamchatka Current (50° N, 160° E)						4. Gulf of Alaska (55° N, 155° W)					
May 1962	May 1961	May Mean (55-60)	$\sigma \frac{ x-\bar{x} }{\sigma}$	Class		May 1962	May 1961	May Mean (55-60)	$\sigma \frac{ x-\bar{x} }{\sigma}$	Class	
$V_E$ -3	-17	-13.7	13.8	0.78	1	$V_E$ -19	1	-1.6	5.4	3.22	3
$U_E$ 5	1	-4.1	10.3	0.88	1	$U_E$ 10	7	17.9	22.4	0.35	1
$-V$ -12	-54	-7.2	33.7	0.14	1	$-V$ -61	-5	-71.5	89.7	0.12	1
$\psi$ 85	484	361.5	204	1.36	2	$\psi$ 62	14	32.9	35.1	0.83	1
$\psi_B$ 98	497	376.6	214	1.30	2	$\psi_B$ 64	14	33.3	35.6	0.86	1
$\psi_0$ 122.9	267.3	227.4	71.0	1.47	2	$\psi_0$ 80.6	99.8	116.3	26.4	1.35	2
$\psi_B$ 134	280.5	241.3	70.5	1.52	2	$\psi_B$ 81.4	99.2	116.0	26.4	1.31	2
2. Oyashio Current (45° N, 155° E)						5. Ocean Station "P" (50° N, 145° W)					
May 1962	May 1961	May Mean (55-60)	$\sigma \frac{ x-\bar{x} }{\sigma}$	Class		May 1962	May 1961	May Mean (55-60)	$\sigma \frac{ x-\bar{x} }{\sigma}$	Class	
$V_E$ -12	-55	-22.1	24.4	0.41	1	$V_E$ -44	-16	-25.9	25.6	0.71	1
$U_E$ 13	27	12.3	16.7	0.04	1	$U_E$ 9	13	32.6	32.1	0.73	1
$-V$ -24	-55	-13.3	25.7	0.42	1	$-V$ 6	-30	-29.5	23.1	3.54	3
$\psi$ -113	129	20.3	131	1.02	2	$\psi$ 1	22.0	2.6	25.1	0.06	1
$\psi_B$ -96	179	58.1	118	1.30	2	$\psi_B$ 4	22.5	4.5	22.0	0.25	1
$\psi_0$ -57.0	84.1	67.3	61.5	2.05	3	$\psi_0$ 23.8	52.1	38.4	17.5	0.83	1
$\psi_B$ -42.2	114.7	96.1	64.0	2.16	3	$\psi_B$ 26.3	58.9	42.2	17.6	0.70	1
3. Kuroshio Current (30° N, 140° E)						6. California Current (35° N, 135° W)					
May 1962	May 1961	May Mean (55-60)	$\sigma \frac{ x-\bar{x} }{\sigma}$	Class		May 1962	May 1961	May Mean (55-60)	$\sigma \frac{ x-\bar{x} }{\sigma}$	Class	
$V_E$ -7	-1	-1.4	2.9	1.93	2	$V_E$ -8	-24	-13.9	14.4	0.30	1
$U_E$ 23	20	14.7	8.6	0.96	1	$U_E$ -37	-16	-20.1	16.9	1.01	2
$-V$ -9	-3	-9.2	4.6	0.04	1	$-V$ 32	48	15.0	66.5	0.25	1
$\psi$ -334	-368	-294.0	77.9	0.51	1	$\psi$ -20	-71	-49.1	21.2	1.37	2
$\psi_B$ -362	-374	-299.9	84.5	0.73	1	$\psi_B$ -19	-67	-46.1	20.9	1.30	2
$\psi_0$ -253.9	-353.4	-302.8	45.5	1.07	2	$\psi_0$ -20.2	-39.3	-35.6	3.7	4.16	3
$\psi_B$ -262.2	-352.8	-306.1	44.3	0.99	1	$\psi_B$ -19.3	-37.3	-33.4	4.1	3.44	3

Apr 1 Apr 30 1962

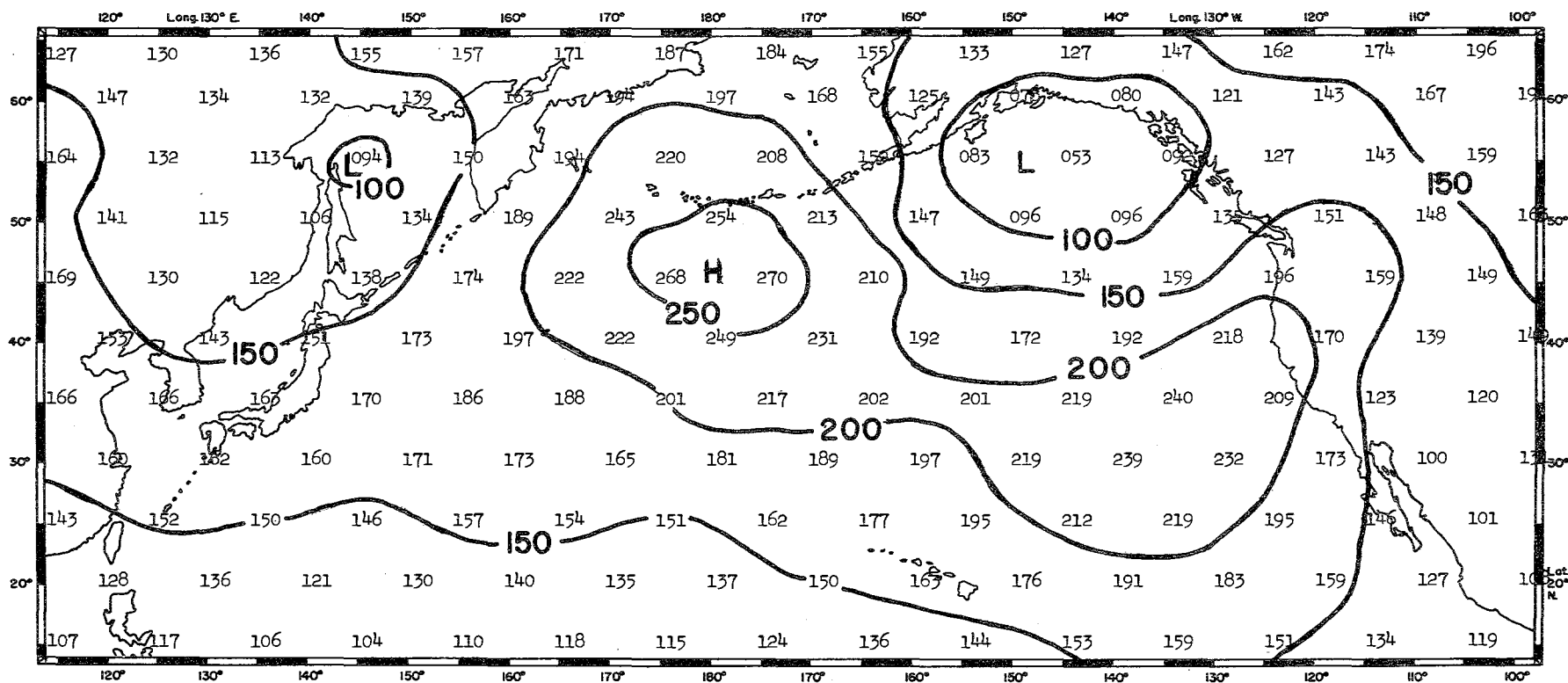

I. Atmospheric Pressure

Apr 1 Apr 30 1962

May 1 May 31 1962

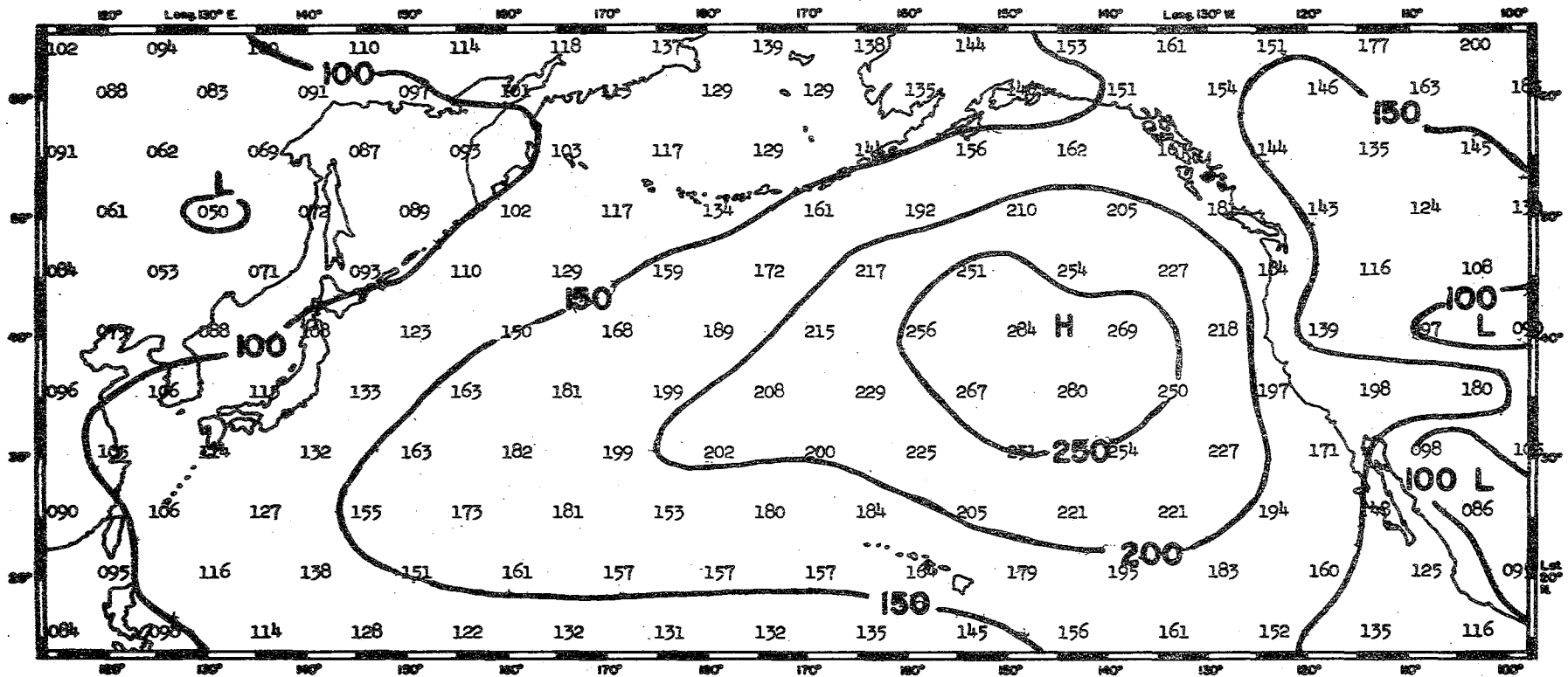

I. Atmospheric Pressure

May 1 May 31 1962

Apr 1 Apr 30 1962

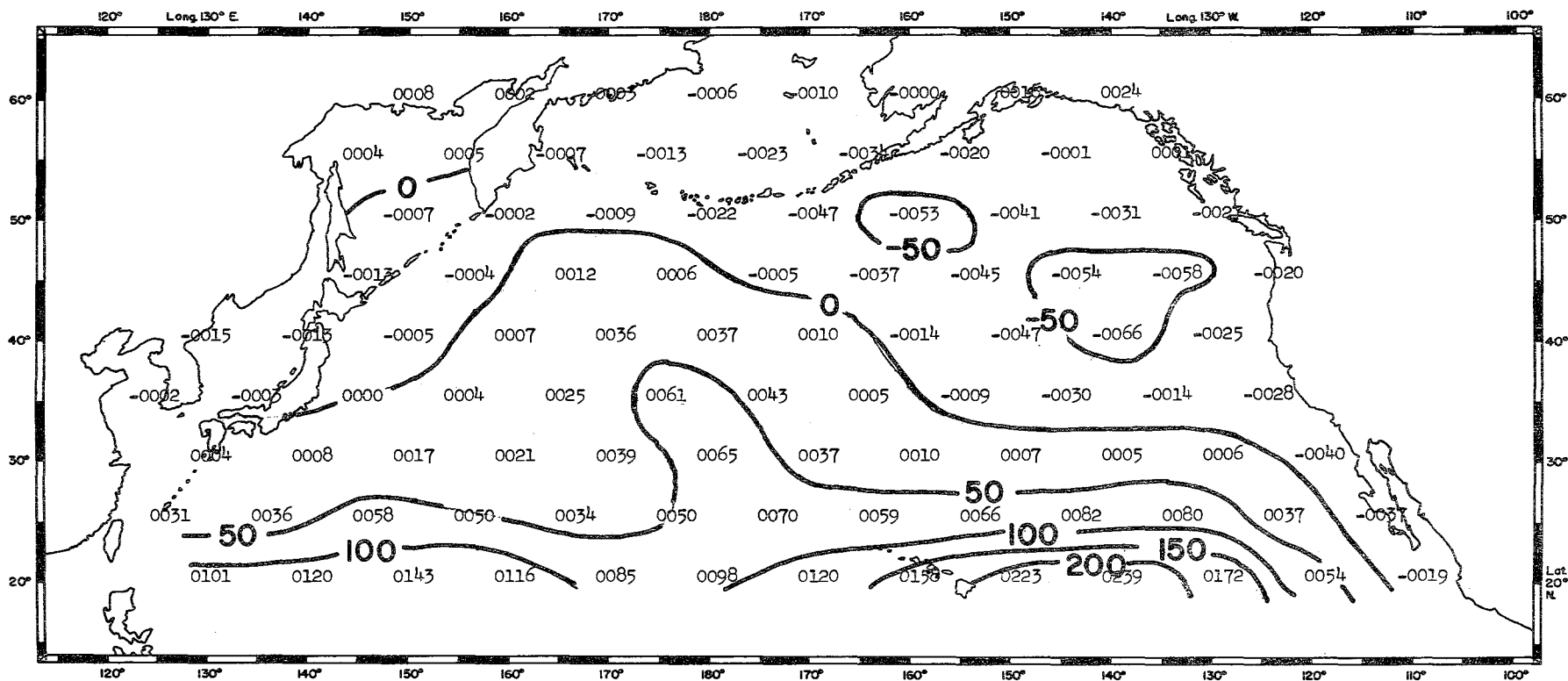

II. Méridional Component of Ekman Transport

Apr 1 Apr 30 1962

May 1 May 31 1962

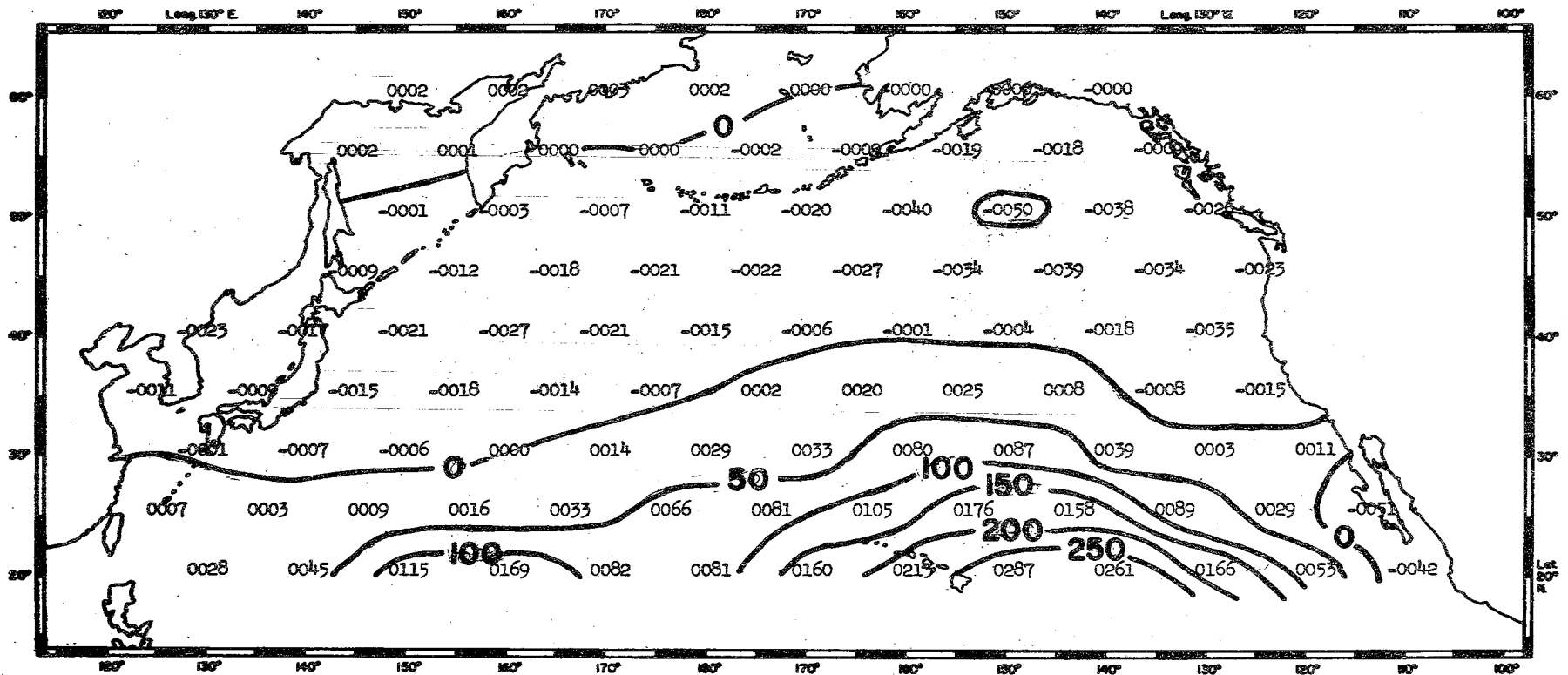

II. Meridional Component of Ekman Transport

May 1 May 31 1962

Apr 1 Apr 30 1962

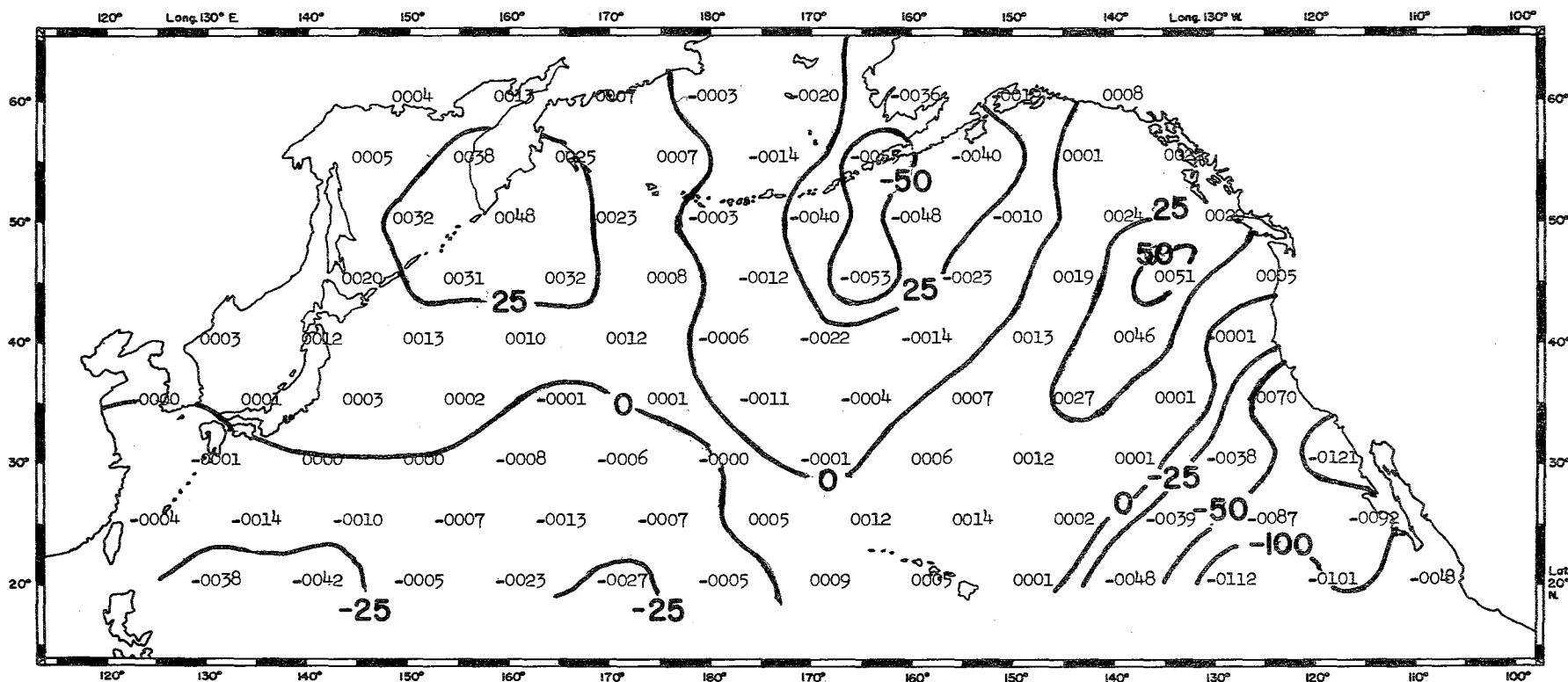

III. Zonal Component of Ekman Transport

Apr 1 Apr 30 1962

May 1 May 31 1962

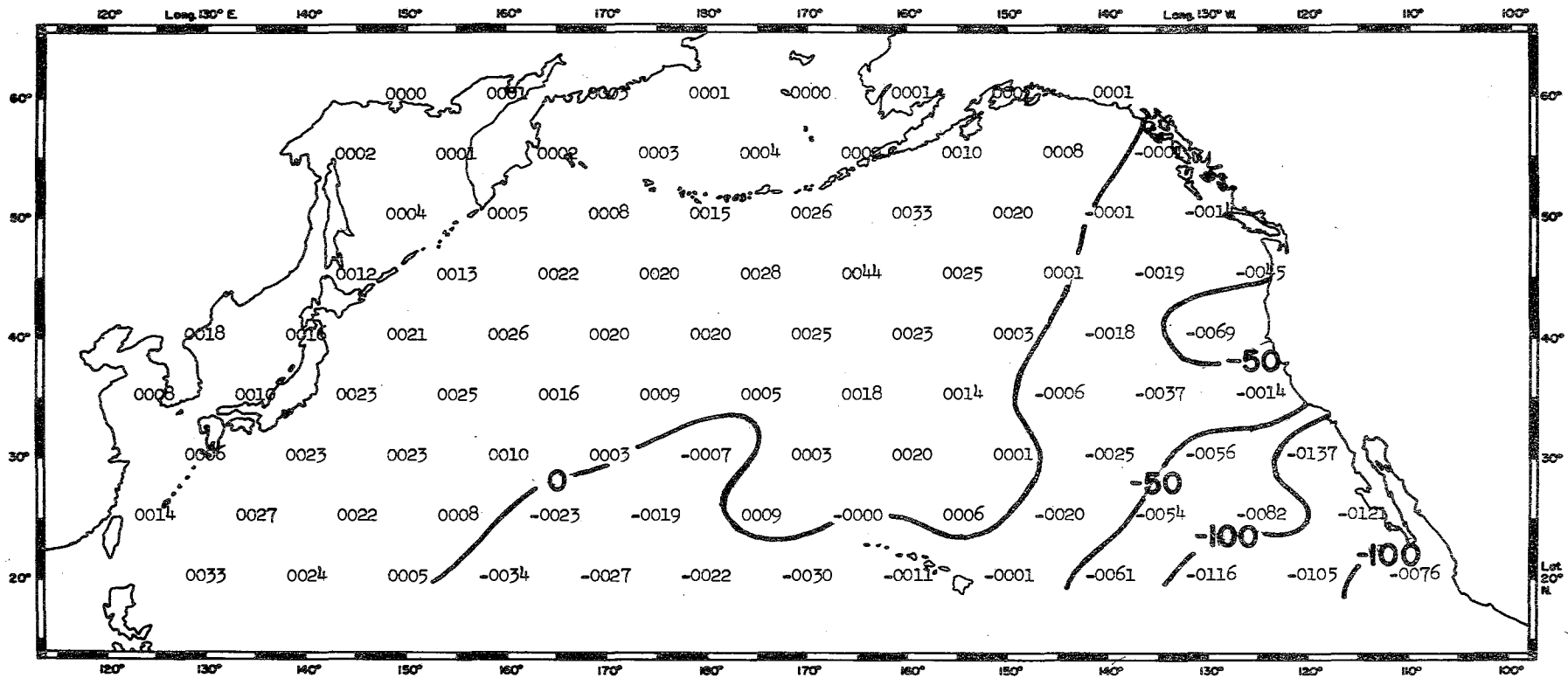

III. Zonal Component of Ekman Transport

May 1 May 31 1962

Apr 1 Apr 30 1962

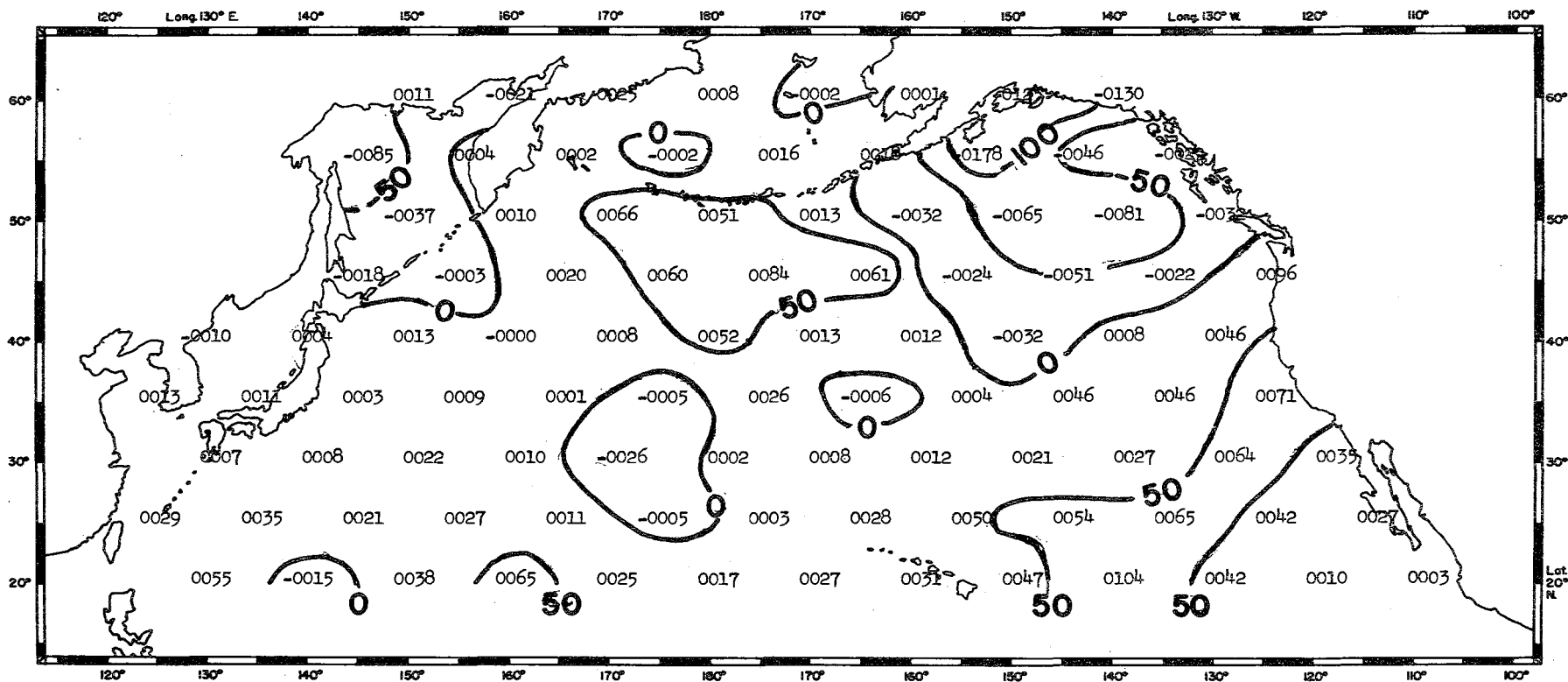

IV. Meridional Component of Total Transport

Apr 1 Apr 30 1962

May 1 May 31 1962

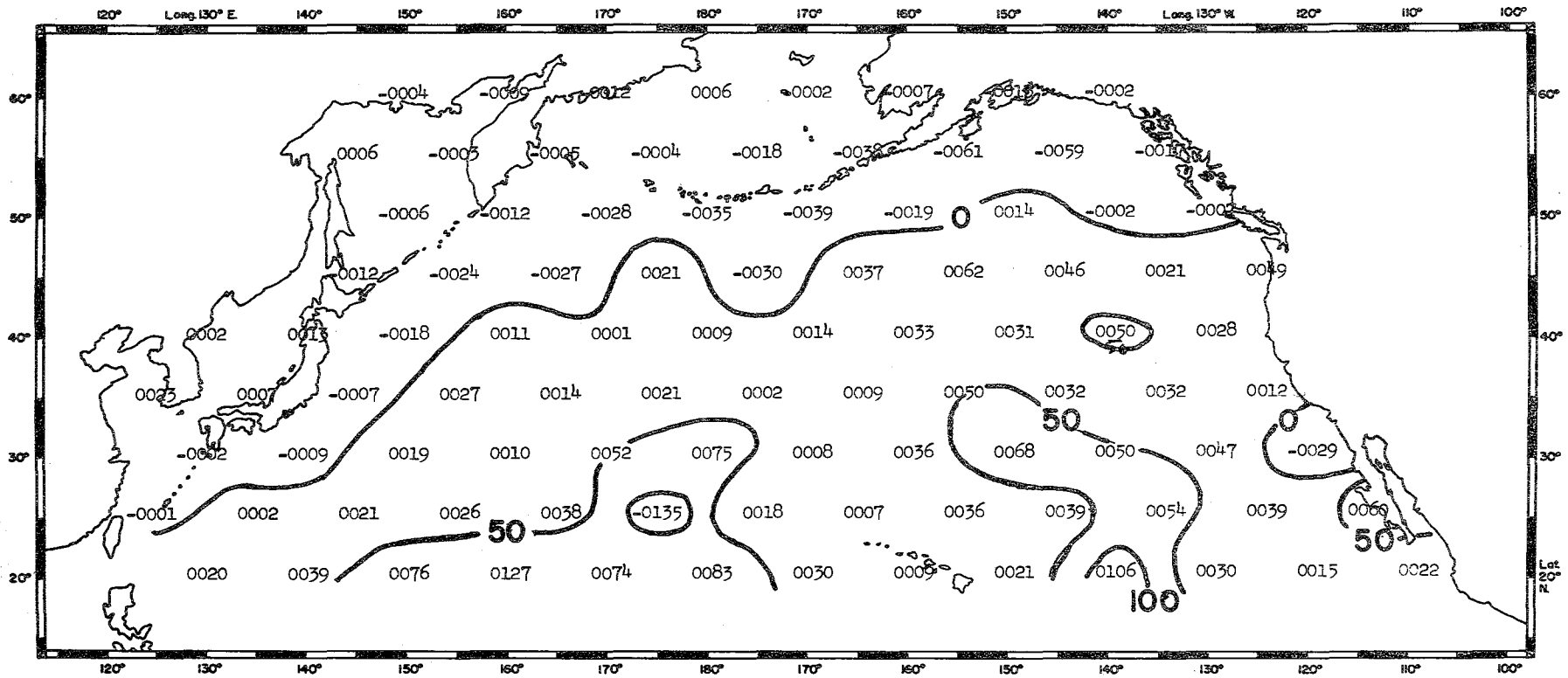

IV. Meridional Component of Total Transport

May 1 May 31 1962

Apr 1 Apr 30 1962

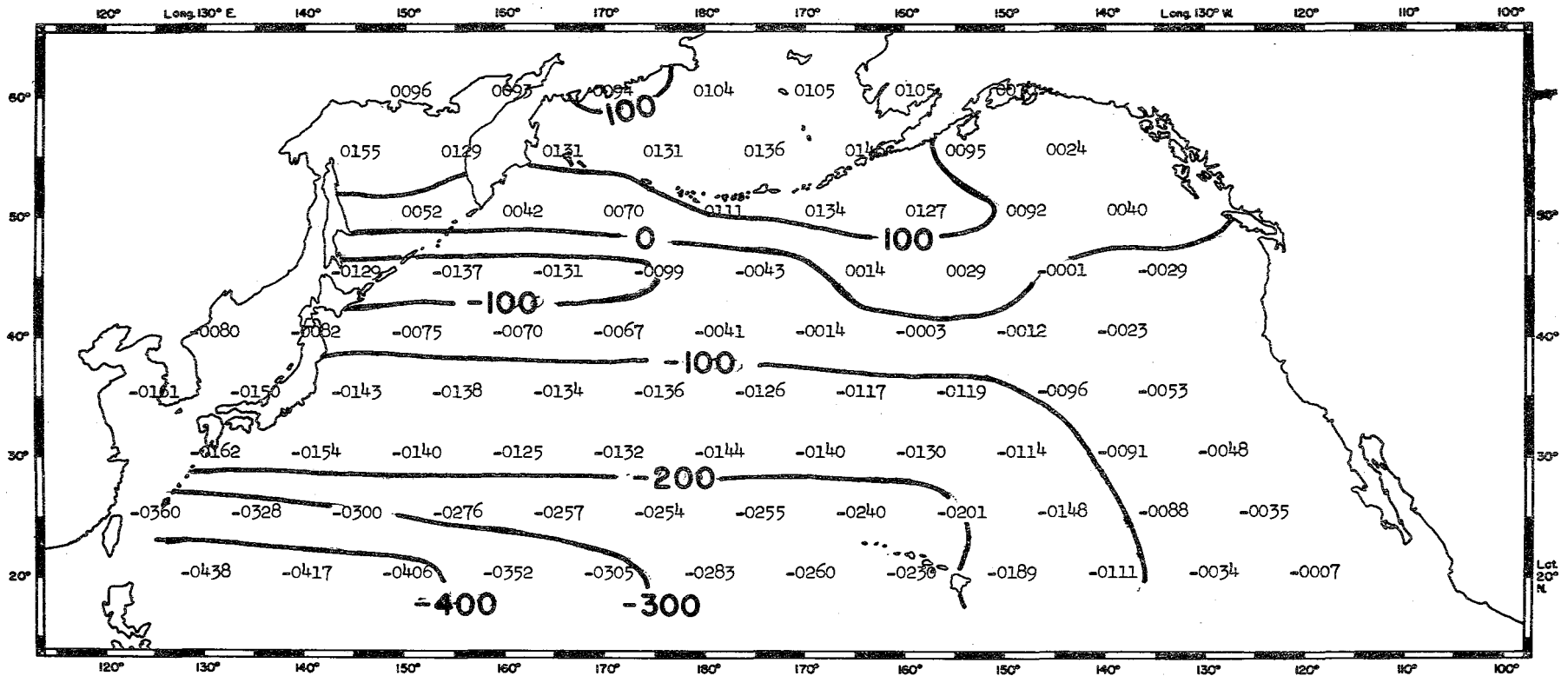

V. Integrated Total Transport

Apr 1 Apr 30 1962

May 1 May 31 1962

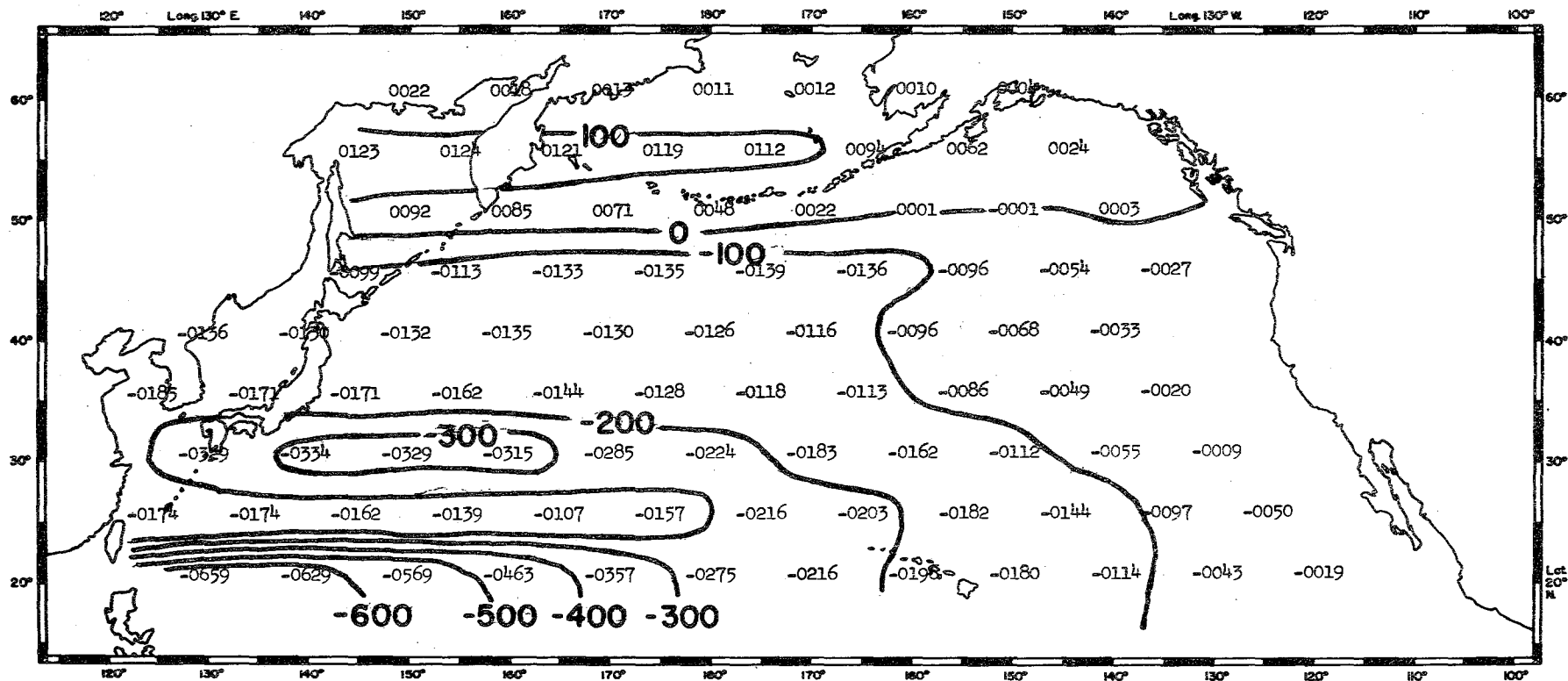

V. Integrated Total Transport

May 1 May 31 1962

Apr 1 Apr 30 1962

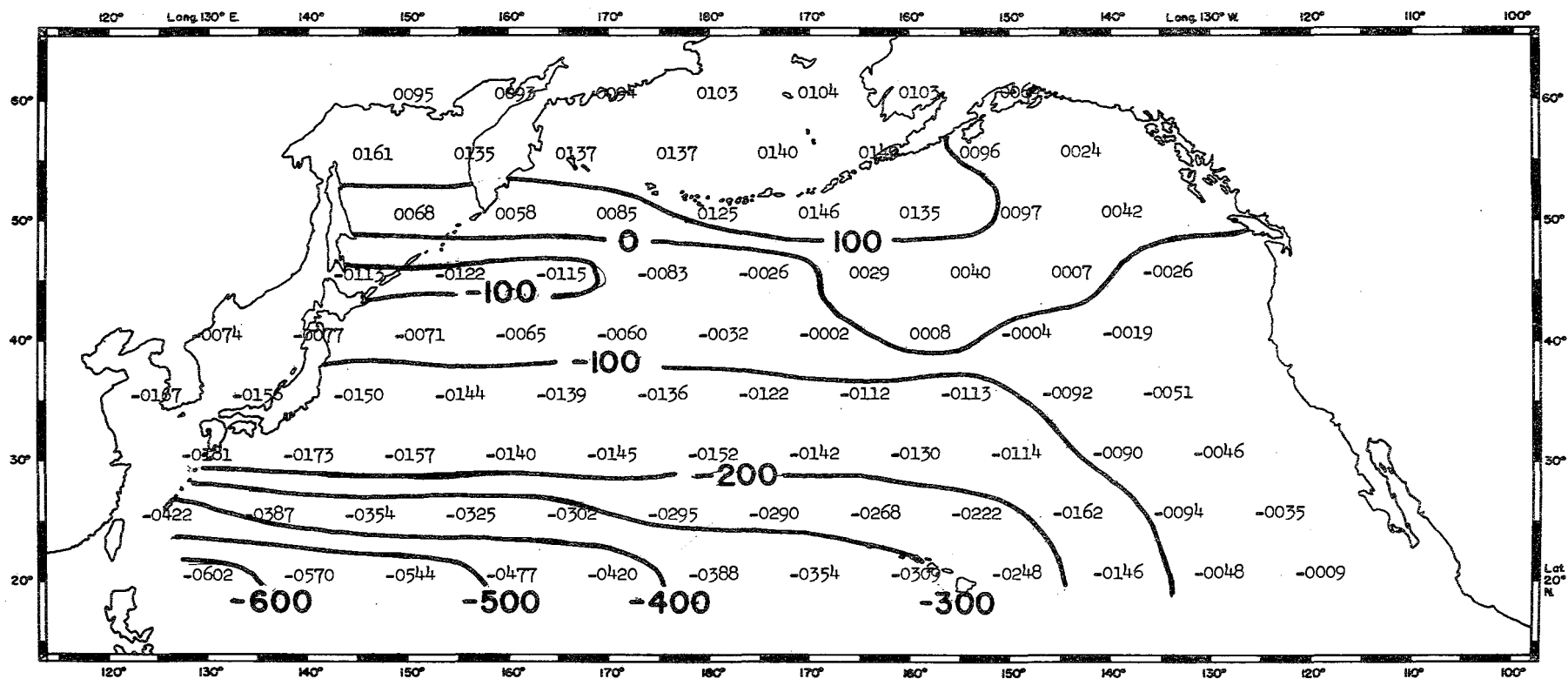

VI. Integrated Geostrophic Transport

Apr 1 April 30 1962

May 1 May 31 1962

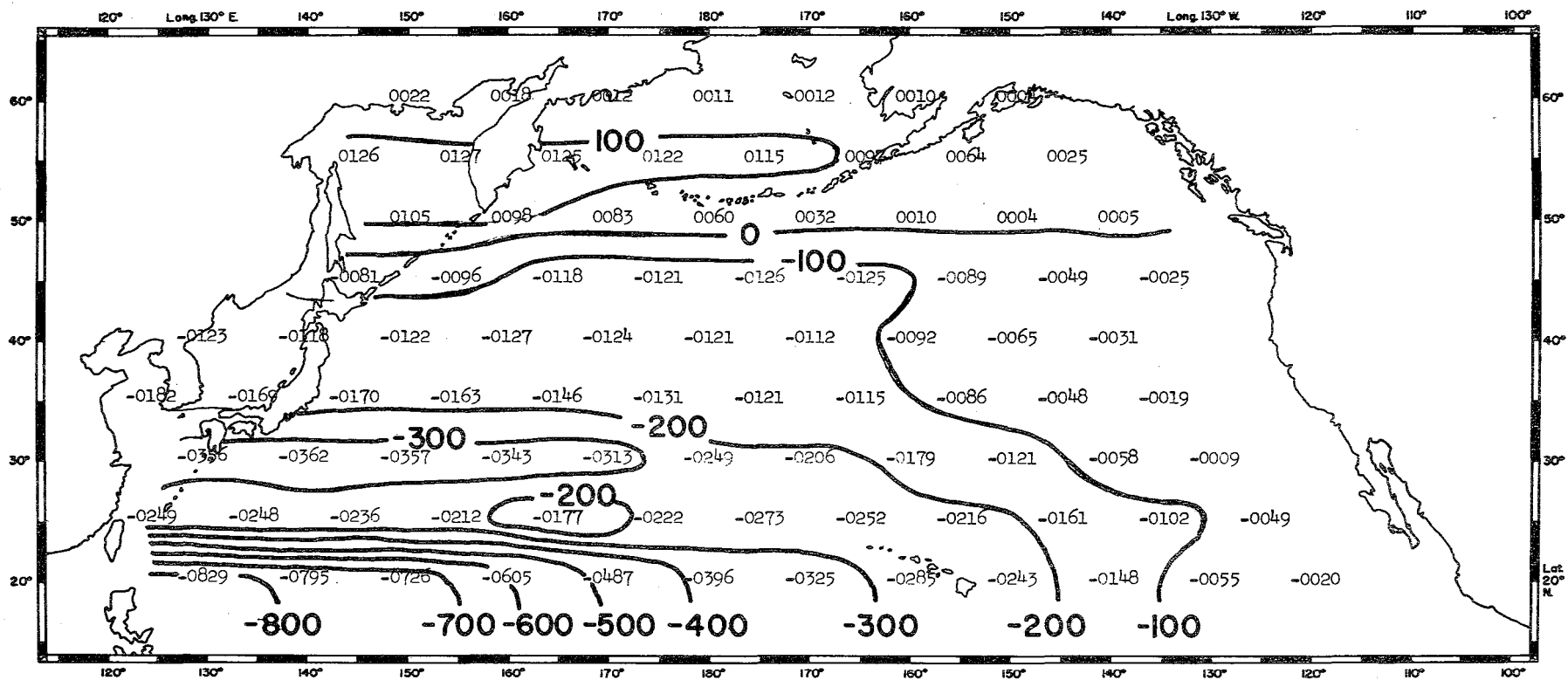

VI. Integrated Geostrophic Transport

May 1 May 31 1962

# MERIDIONAL COMPONENT OF EKMAN TRANSPORT in 10 metric tons/second/kilometer

----- 1962

○ (1955-60) mean ± σ

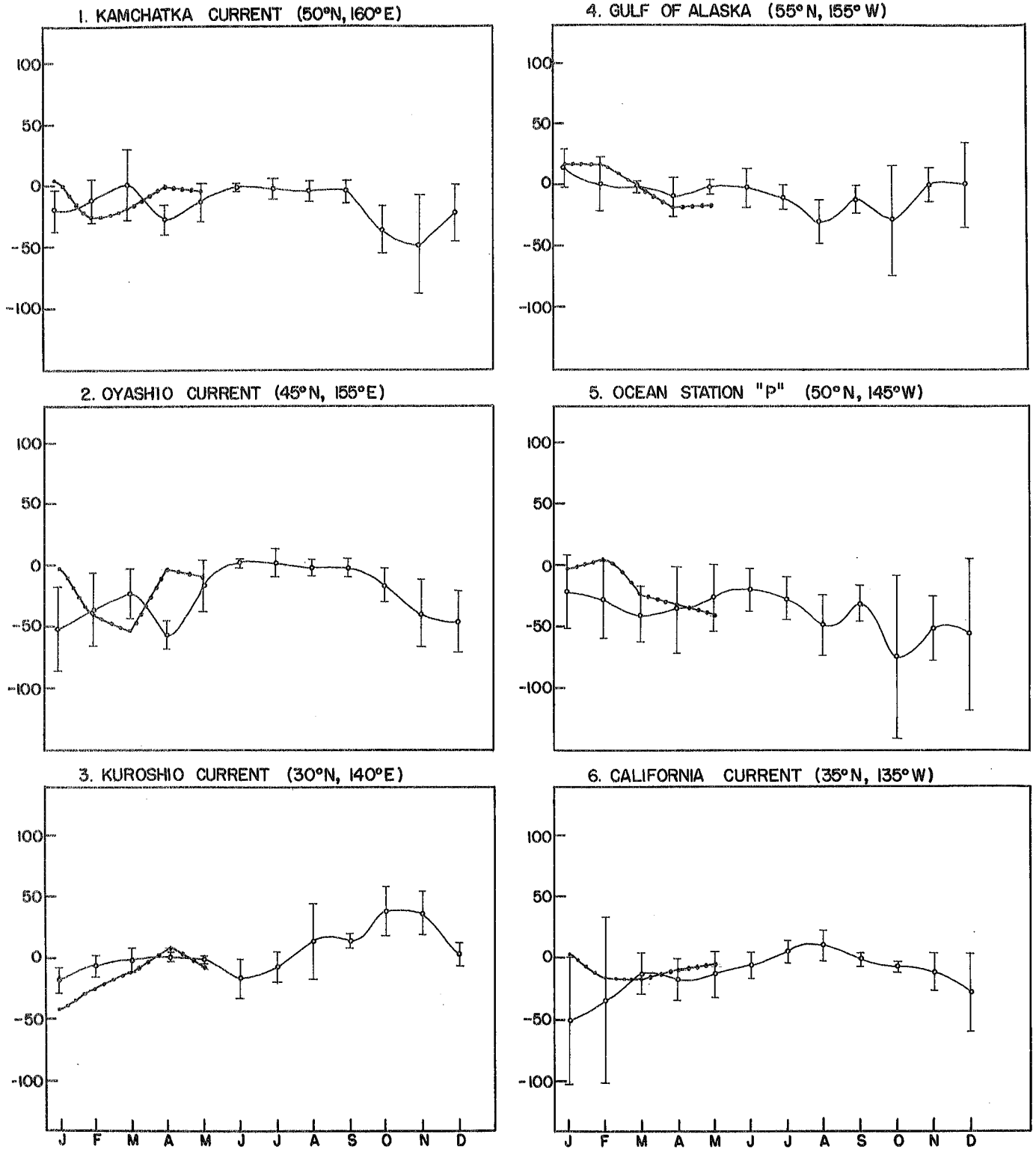

Figure 1

## ZONAL COMPONENT OF EKMAN TRANSPORT in 10 metric tons / second / kilometer

◆◆◆ 1962

○ (1955-60) mean ±σ

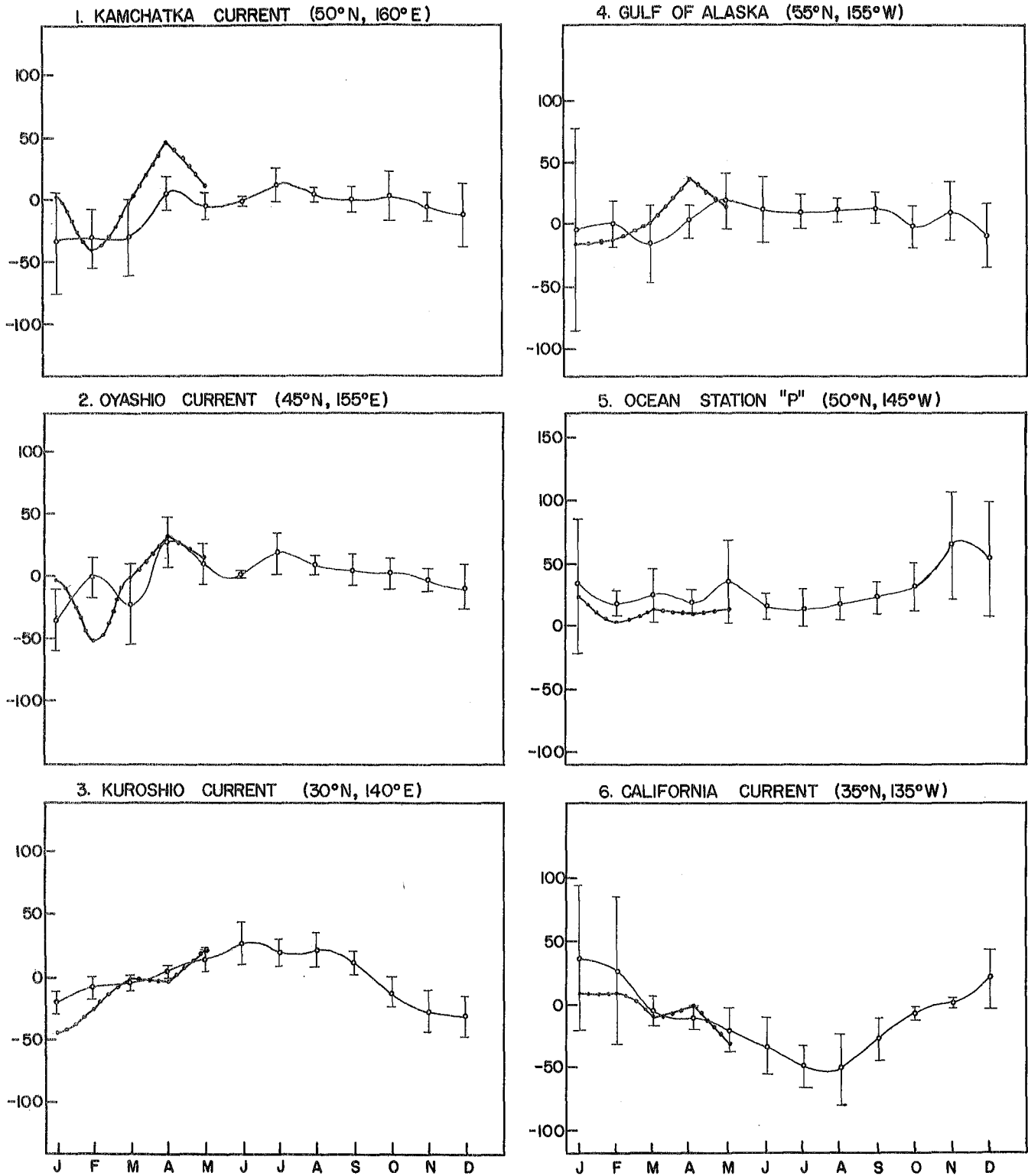

Figure 2

MERIDIONAL COMPONENT OF TOTAL TRANSPORT  
in 100 metric tons/second / kilometer

●—● 1962

⊥ (1955-60) mean  $\pm \sigma$

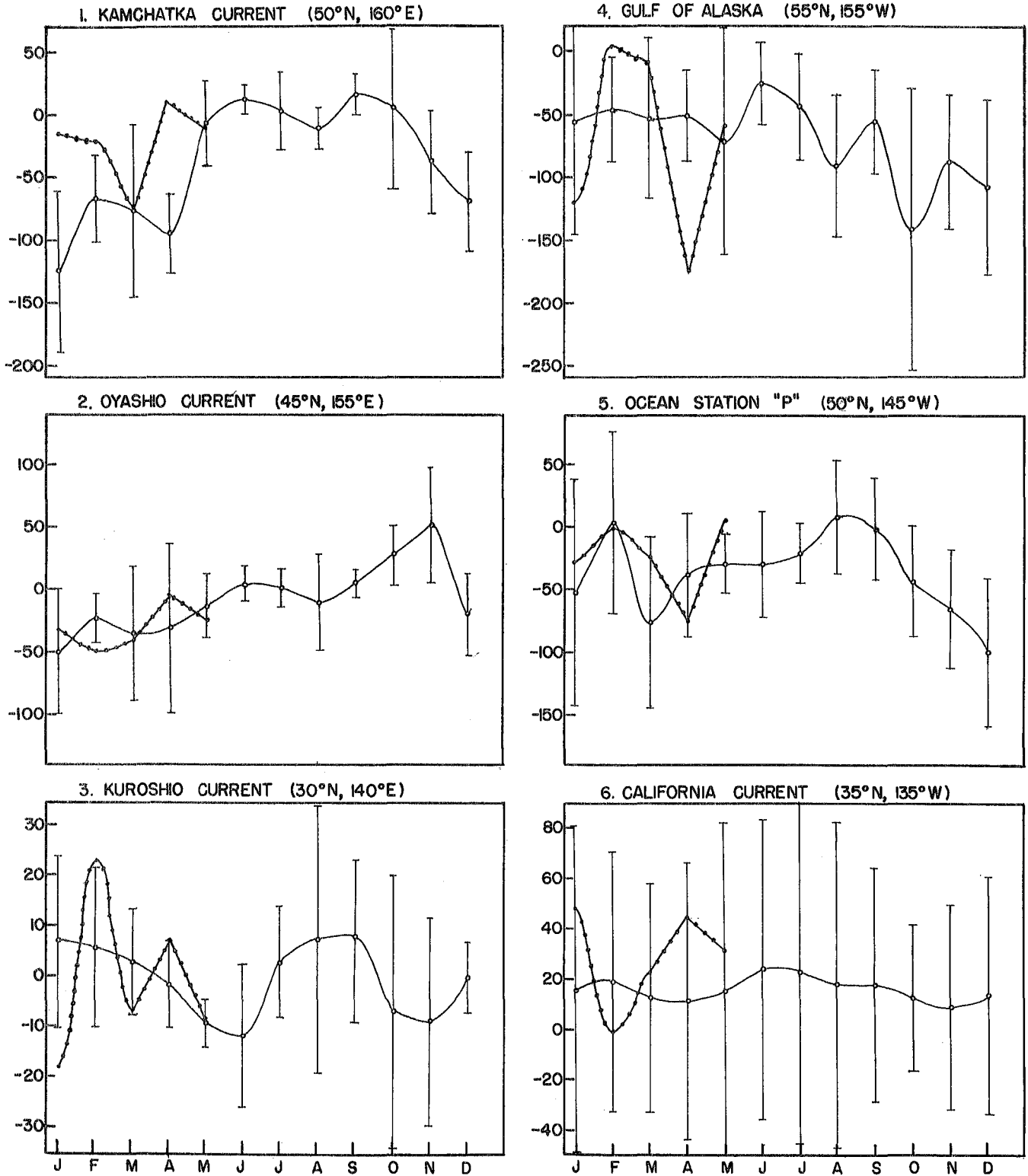

Figure 3

# INTEGRATED TOTAL TRANSPORT in millions of metric tons /second

●—● 1962

○ (1955-60) mean ±  $\sigma$

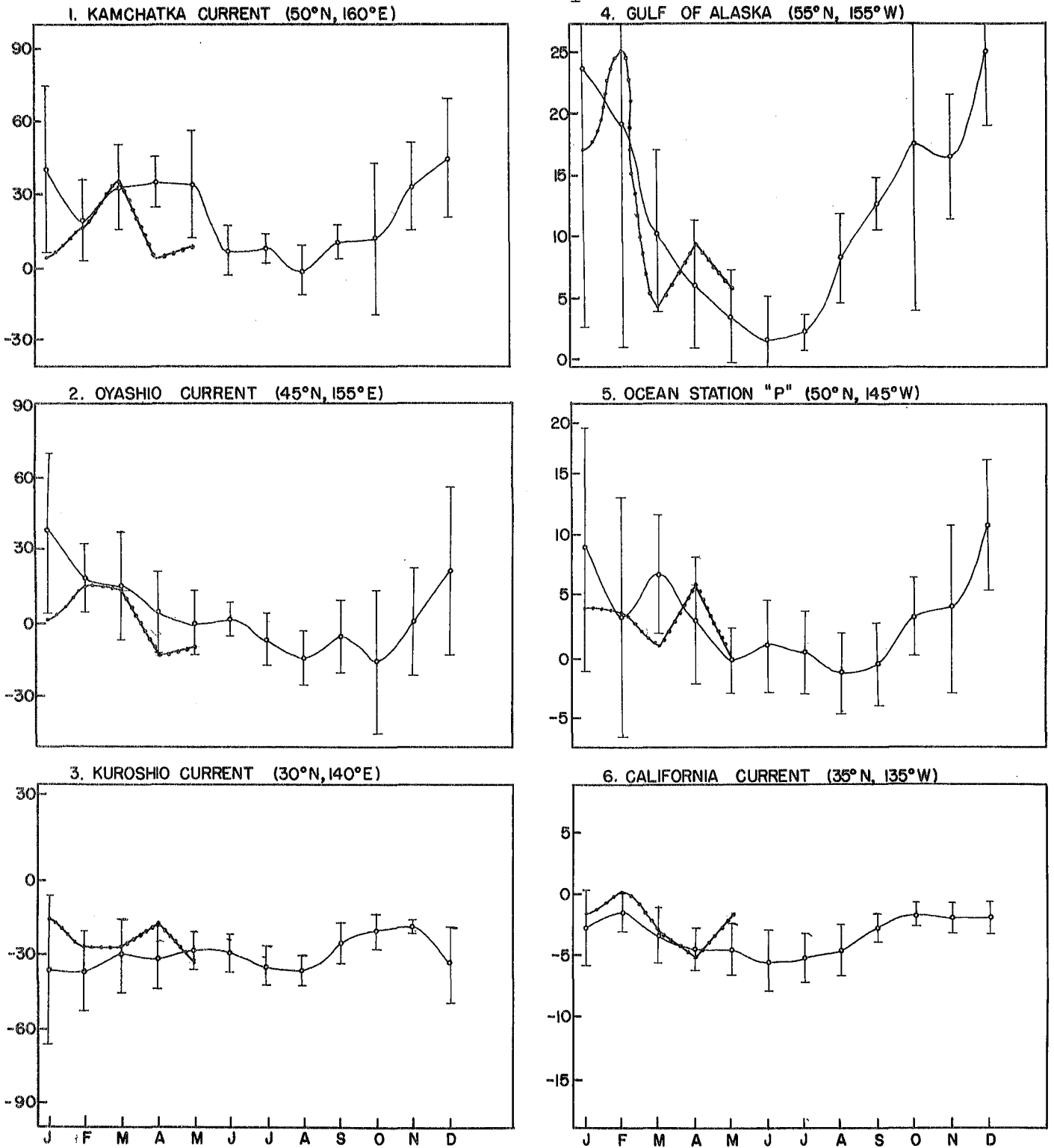

Figure 4

# INTEGRATED GEOSTROPHIC TRANSPORT in millions of metric tons/second

—●— 1962

—○— (1955-60) mean  $\pm \sigma$

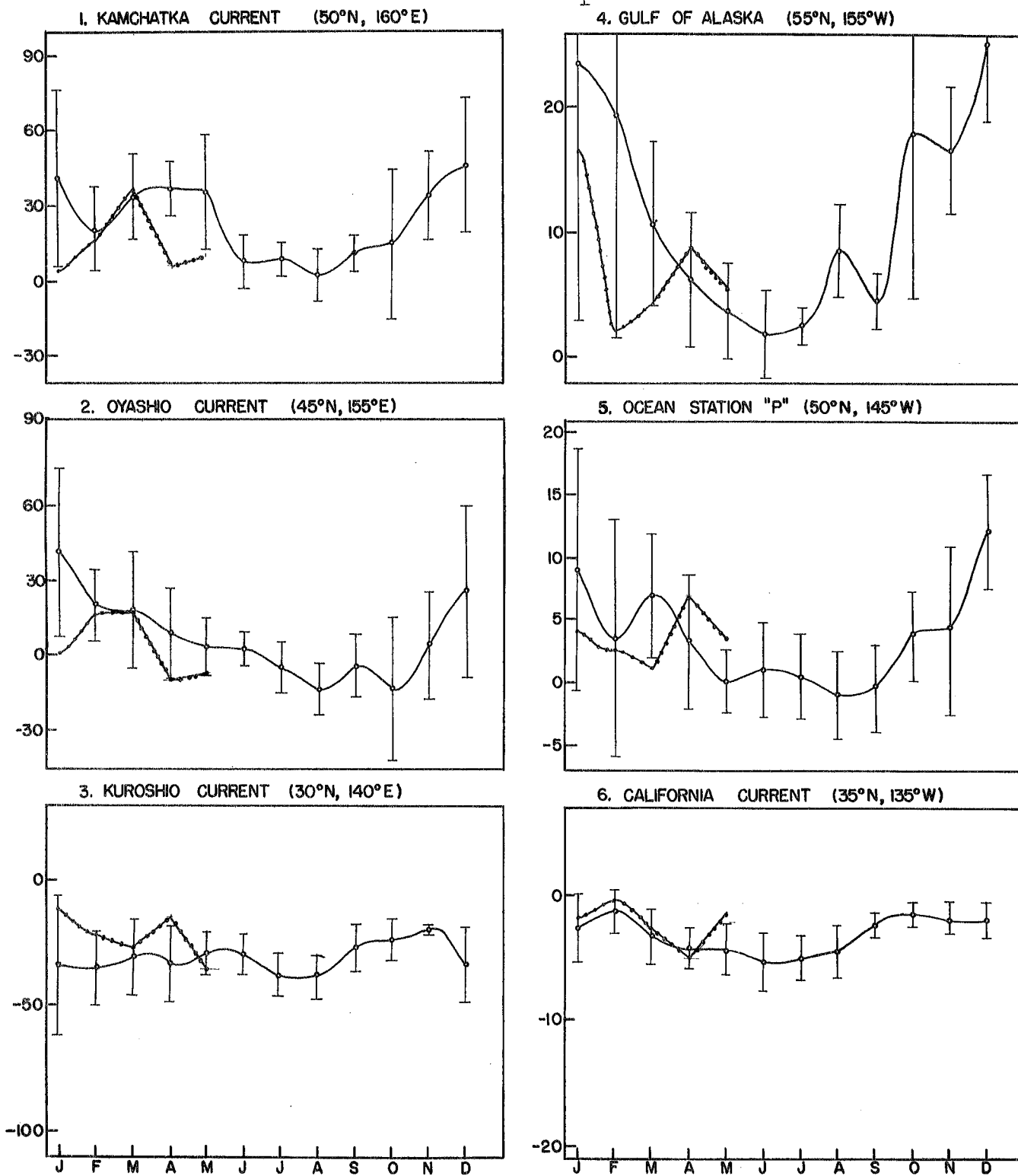

Figure 5

# TREND OF INTEGRATED TOTAL TRANSPORT in millions of metric tons/second

—●— 1962

| (1955-60) mean  $\pm \sigma$

1. KAMCHATKA CURRENT (50°N, 160°E)

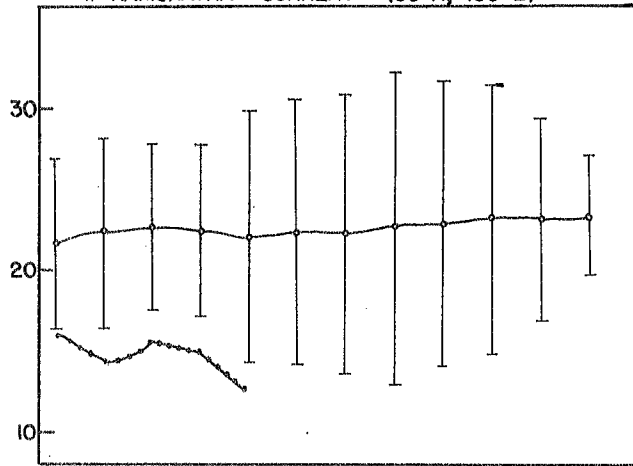

4. GULF OF ALASKA (55°N, 155°W)

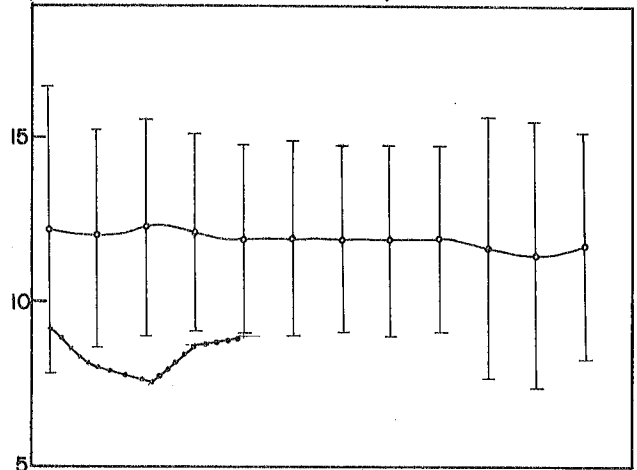

2. OYASHIO CURRENT (45°N, 155°E)

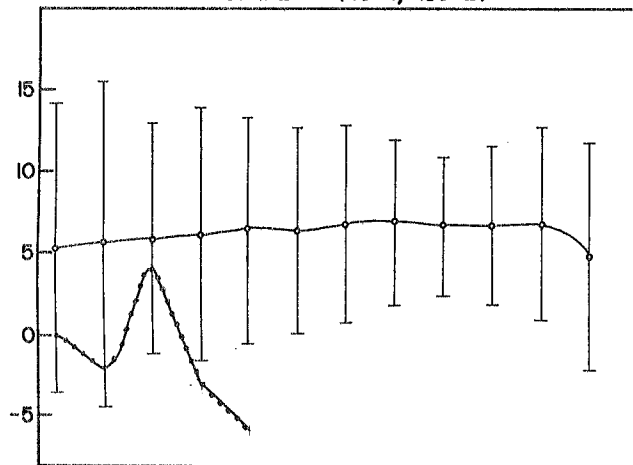

5. OCEAN STATION "P" (50°N, 145°W)

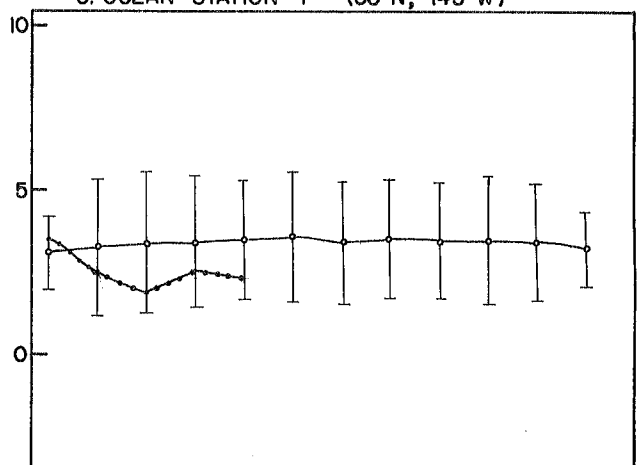

3. KUROSHIO CURRENT (30°N, 140°E)

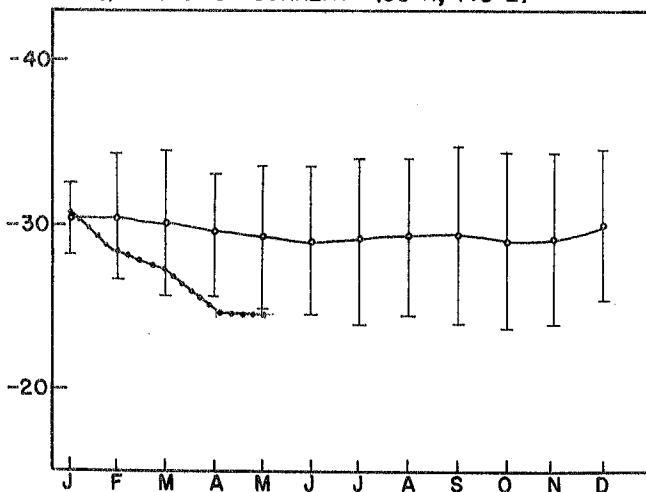

6. CALIFORNIA CURRENT (35°N, 135°W)

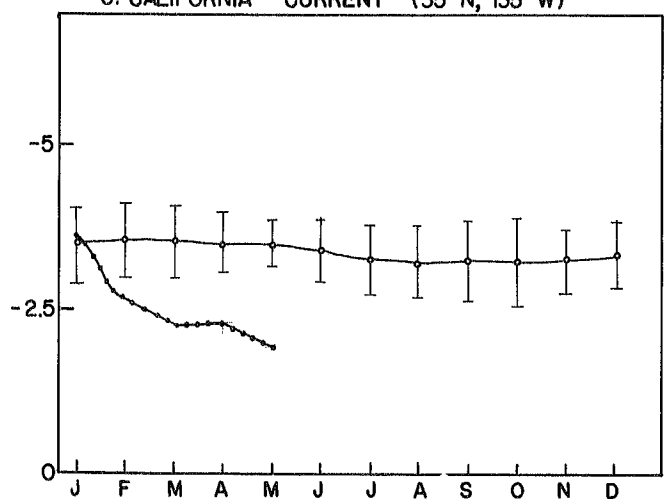

Figure 6

# TREND OF INTEGRATED GEOSTROPHIC TRANSPORT in millions of metric tons/second

—●— 1962

| (1955-60) mean ±  $\sigma$

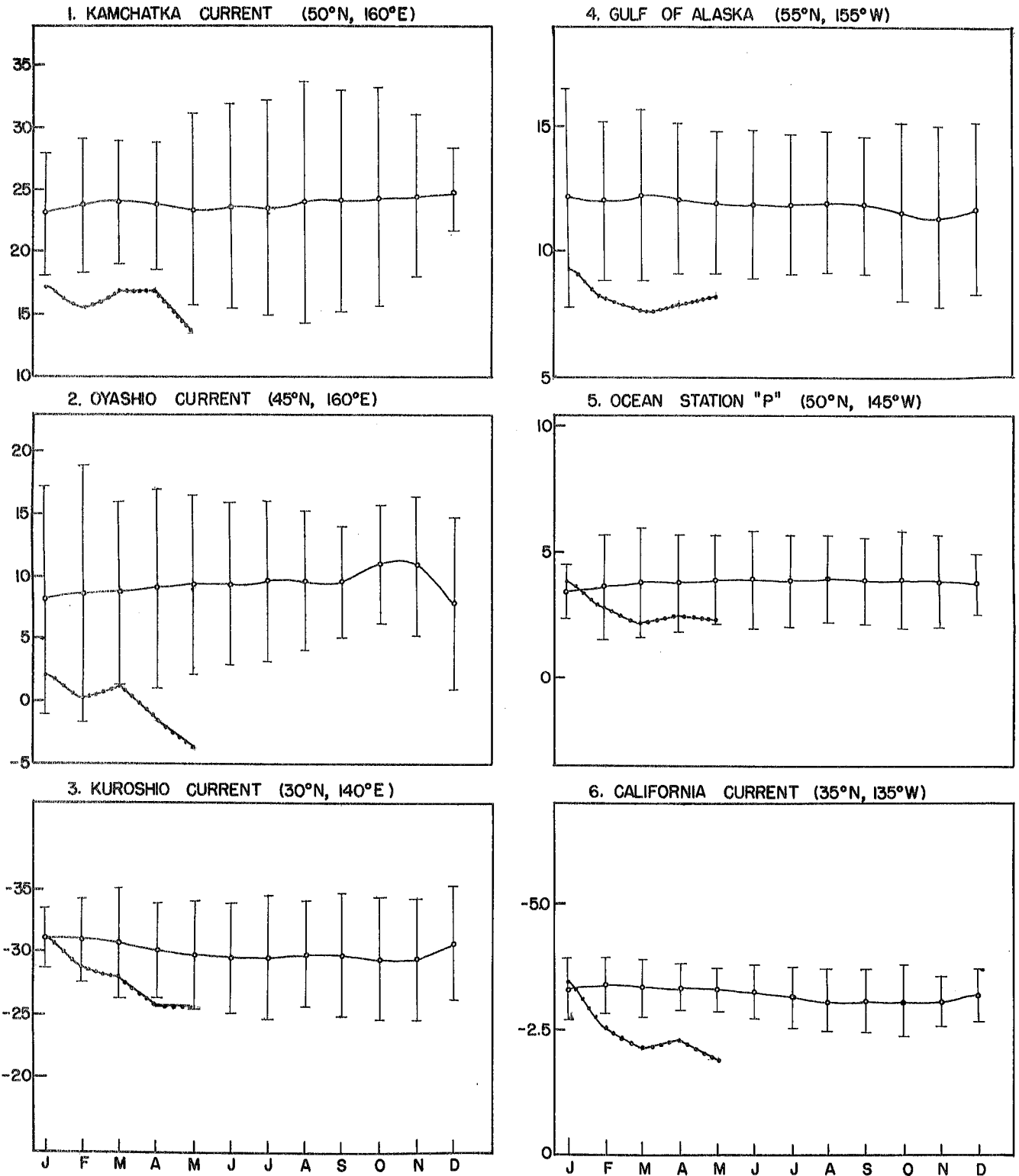

Figure 7

*Dr. Neidler*

FISHERIES RESEARCH BOARD OF CANADA

Pacific Oceanographic Group  
Nanaimo, B. C.

Circular 1962 - 19  
August 23, 1962

Sea Temperatures and Salinities Observed Between "Swiftsure" and  
Ocean Station "P" During 28 June-2 July and 1 August-6 August

The report is based on the data received from C.C.G.S. "Stonetown" and C.C.G.S. "St. Catharines". The information from the C.C.G.S. "St. Catharines" was radioed in on the 16 August 1962.

Figure 2 is made up of two continuous records of temperature (28 June-2 July and 1 August-6 August) at the 3 metre depth along the Line "P"- "S". A prominent feature of the "outbound" temperature record is the many sharp discontinuities in the temperature gradients. These discontinuities are fewer and not as acute on the "inbound" temperature record. The near surface temperatures seaward of Station 2 show an increase of 3°C in the interval between observations. Toward the coast from Station 2, the increases were 2°C and less. The peak temperature on the "outbound" passage was between Station 1 and 2. On the "inbound" passage, the peak had shifted seaward to Station 4.

A comparison of the temperature distribution along Line "P"- "S" (Fig. 3) during late June with that in early August shows that the top of the seasonal thermocline has magnified and has formed closer to the sea-surface (~10 m depth). The early August observations of temperature distribution indicate that at Station 1 the temperature gradient is noticeably steep from the surface to 50 metres. This sharp temperature fall is associated with "upwelling" in this area. The early August observations indicate that Station 4 is in the centre of a pool or band of warm water extending from the surface to a depth of 100 metres. One explanation for this pool of (low salinity) warm water may be the piling up of coastal water relocated as a result of the "upwelling". The other explanation could be the northeastward transport of Columbia River Water. The presence of the temperature inversion between Stations 6A and 5 in the early August observations will again be mentioned in association with a related feature in Figure 4.

Figure 4 shows the temperature changes along the Line "P"- "S" between early August and late June observations. The large decreases in temperature at Station 1 is attributed to the occurrence of coastal "upwelling". At Station 4, the depth and degree of warming is again noticeable. The temperature inversion between Stations 6A and 5 (Fig. 3) lies just within the zone registering a drop in temperature in the five weeks between observations.

Figure 5, complimentary to Figure 3, shows the salinity distributions along the Line "P"- "S" for the same two periods of observations (1 August-6 August and 28 June-2 July). The upward slope of the isohalines at Station 1, in early August observations, repeat the indication of "upwelling" at this area of the coast, whereas the late June observations at Station 1 show the isohalines to be horizontal pointing out the absence of "upwelling".

*For my book  
Owen*

The temperatures at the depth of the 33.8 ‰ isohaline along the Line "P"- "S" are greater than 6.5°C east of Station 4 and less than 6.5°C west of Station 4. This condition serves to mark Station 4 as the western boundary of an intrusion of warm water northward along the coast.

The salinity changes along the Line "P"- "S" between early August (1 August- 6 August) and late June (28 June-2 July) are pictured in Figure 6. The "upwelling", at Station 1, during early August results in a considerable increase in salinity to a depth of at least 200 metres over the previous five weeks. The zones of significant salinity changes, located at Stations 2, 3, 5, and 6, correspond with the zones of significant temperature changes (Fig. 4). (Salinity increases are related to temperature decreases and salinity decreases with temperature increases).

The two most obvious features in the early August data are the "upwelling" at the coast and the pool of warm low salinity water in the surface 100 metres at Station 4.

W. Atkinson

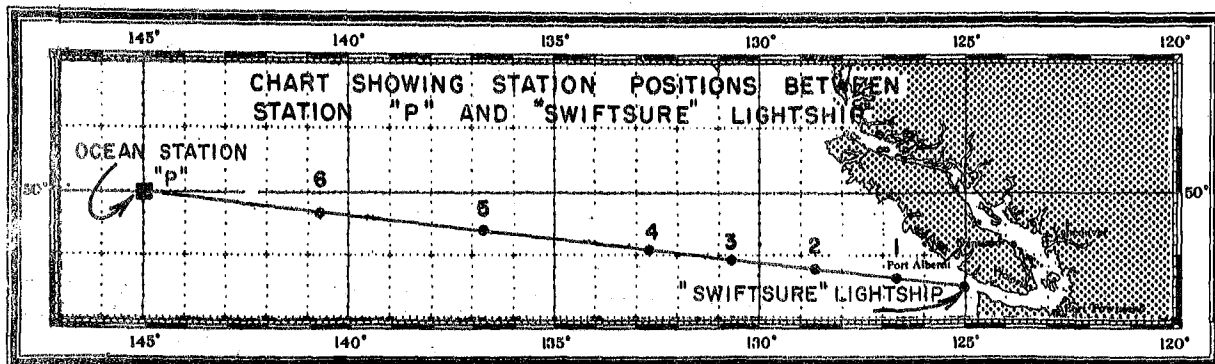

Figure 1.

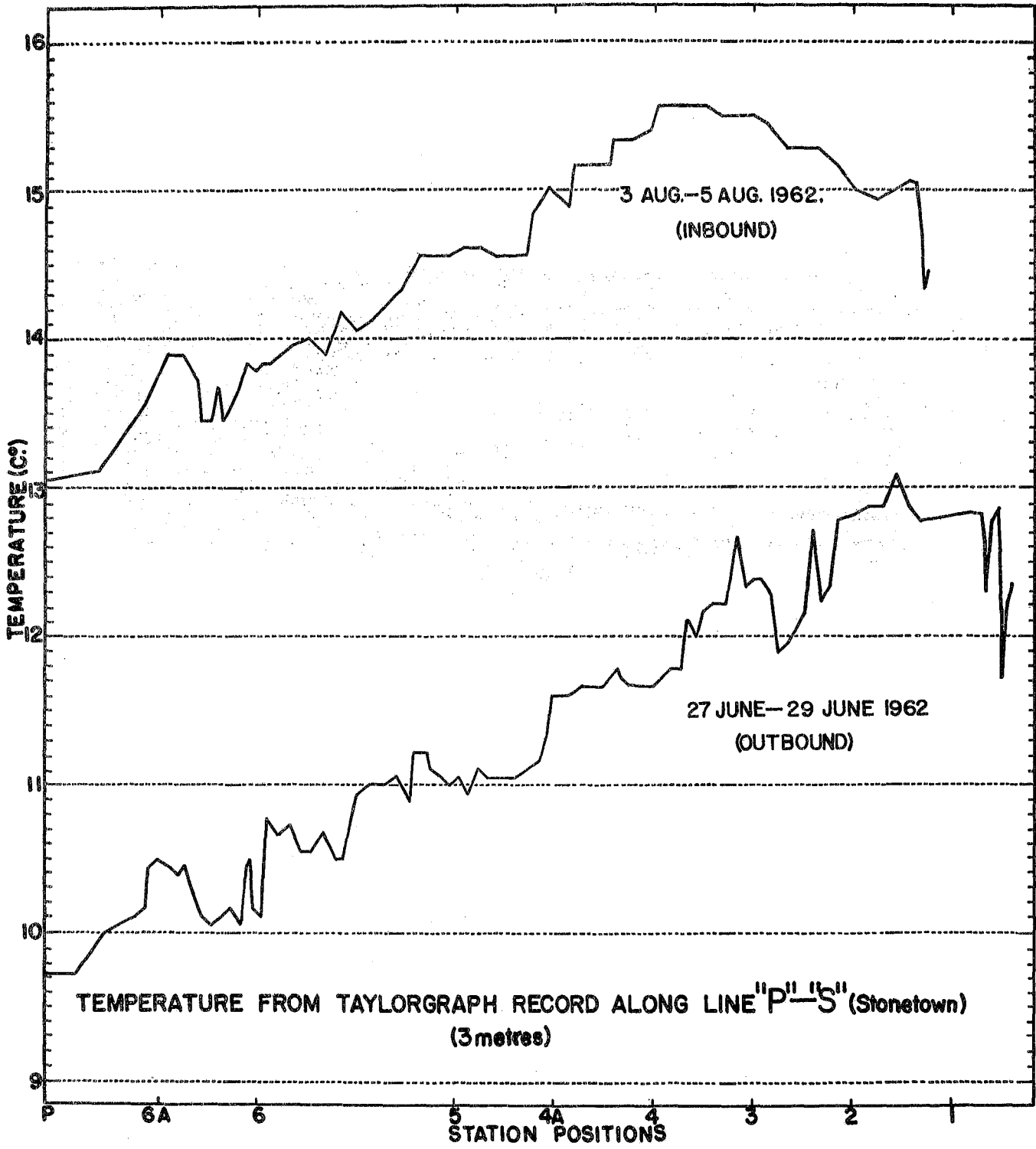
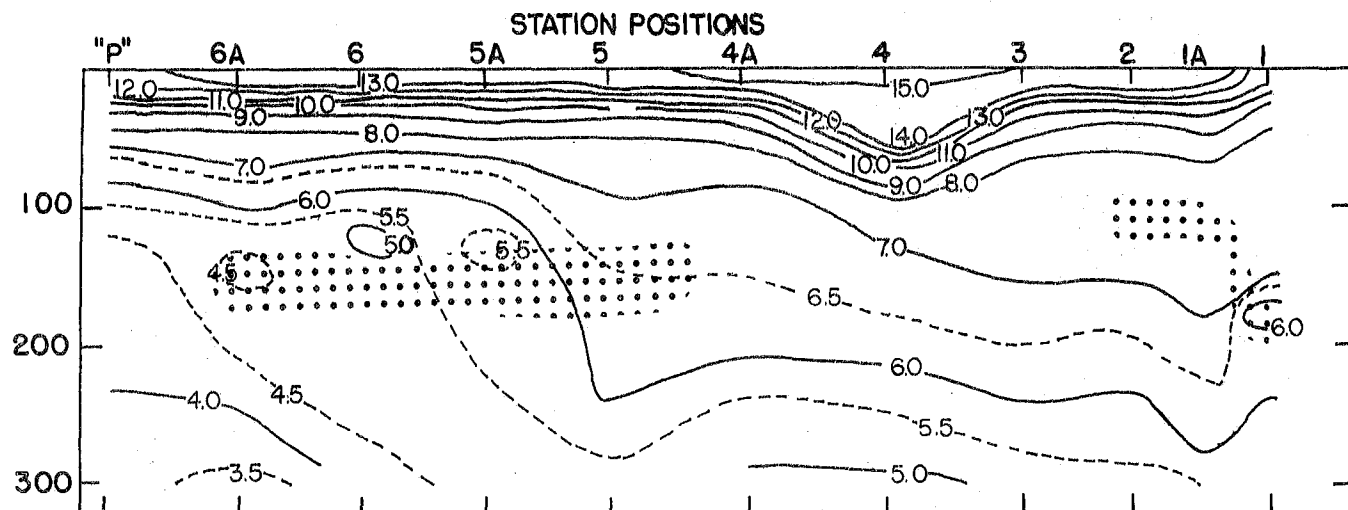
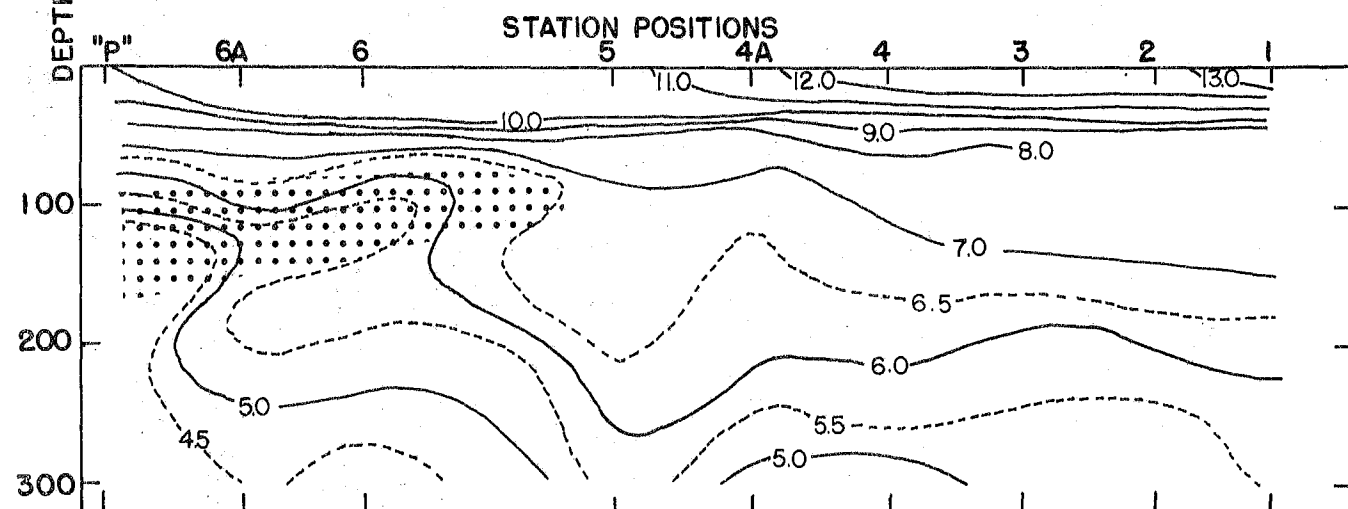

FIGURE 2



1 AUGUST—6 AUGUST  
1962

⋯ TEMP. INVER.



28 JUNE—2 JULY  
1962

VERTICAL SECTIONS OF TEMPERATURE(C°) ALONG P-S LINE.

FIGURE 3

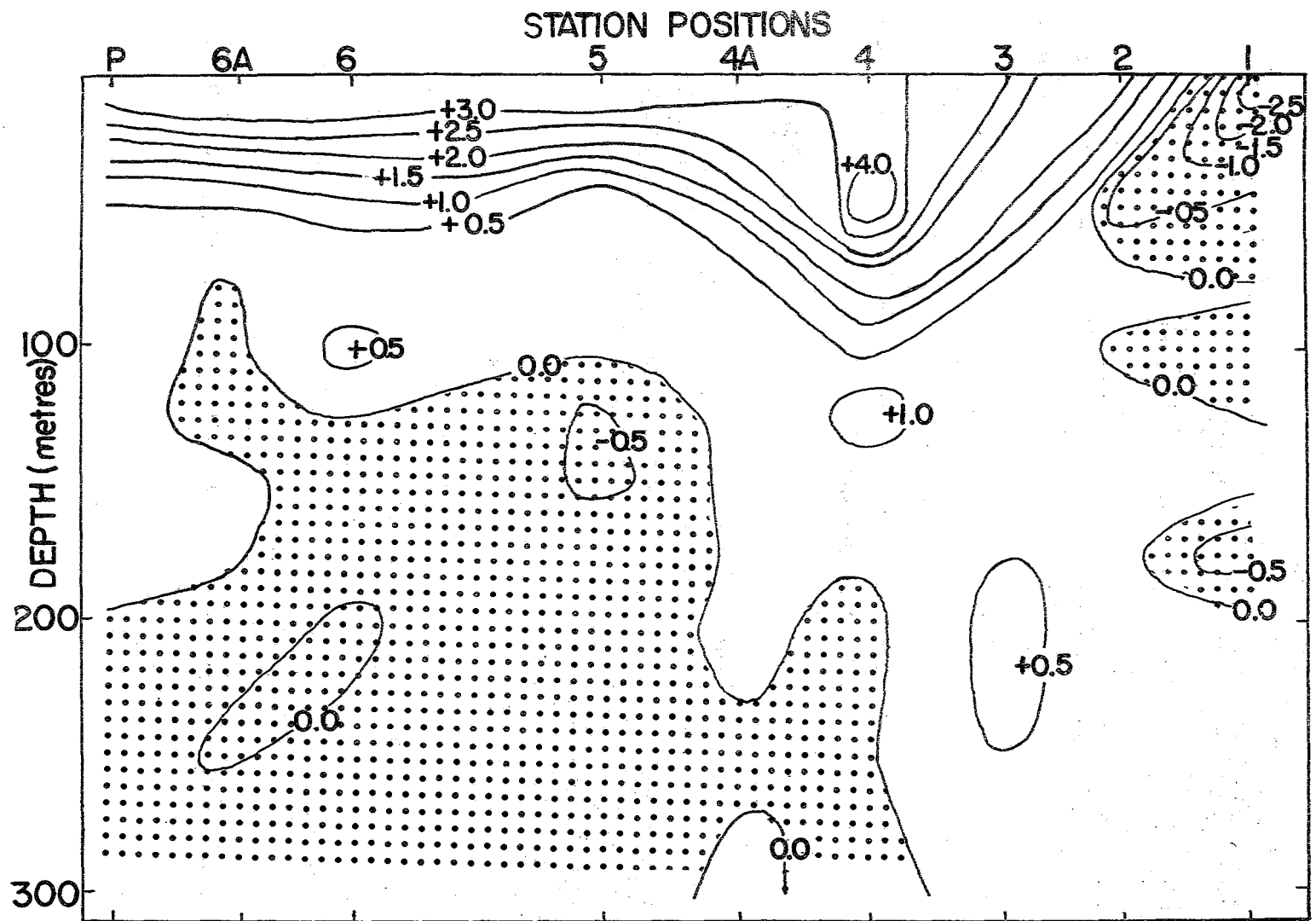

TEMPERATURE(°C) CHANGE ALONG "P"-S" LINE  
 (1 AUG.—6 AUG.) — (28 JUNE—2 JULY)

FIGURE 4

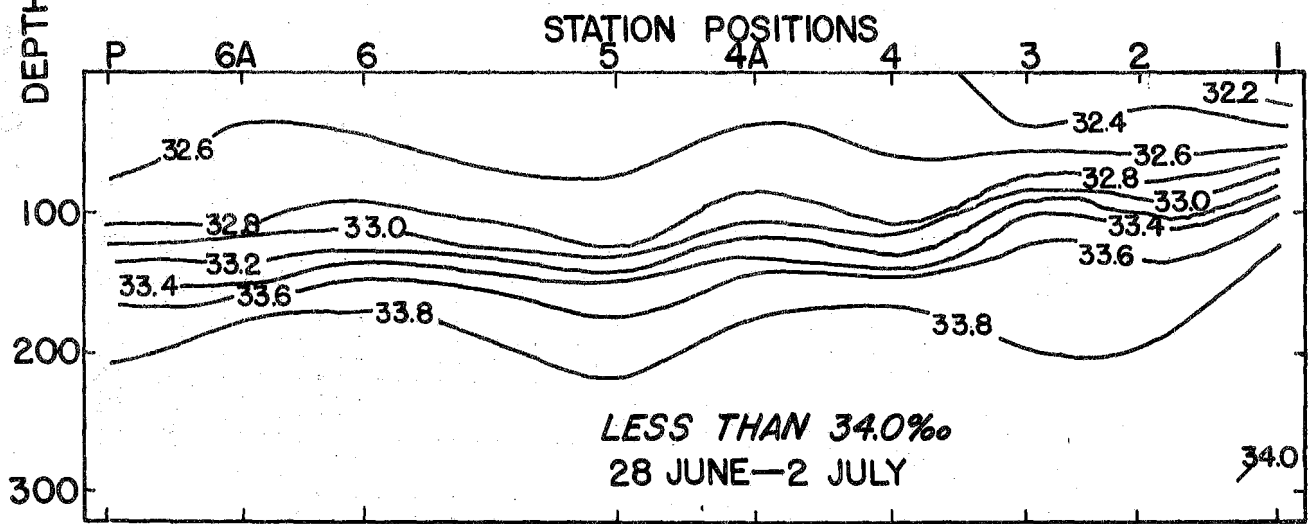
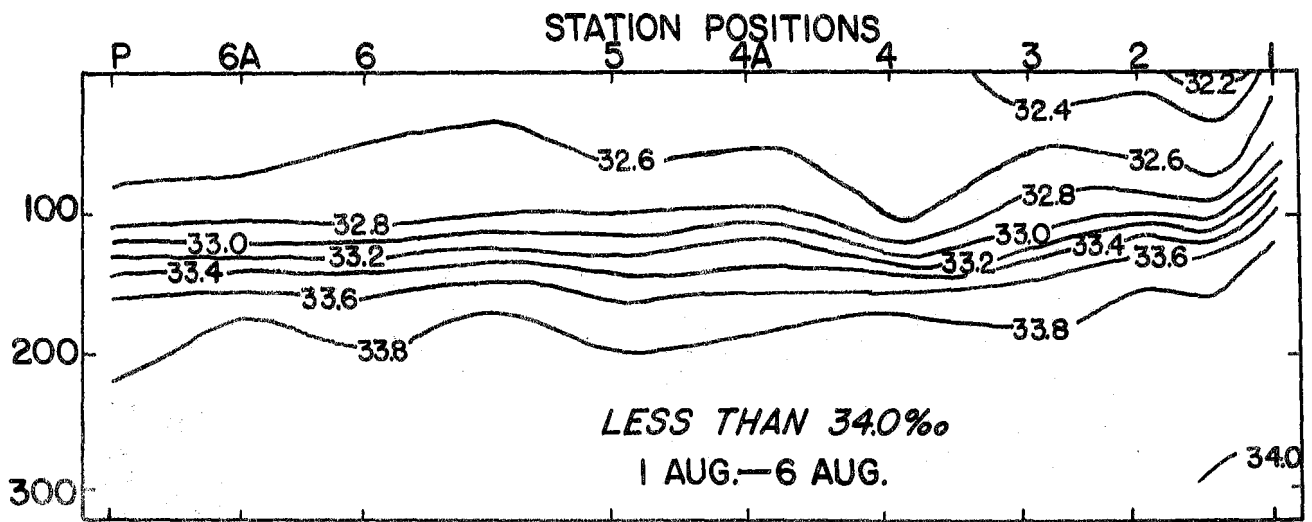

1962.

VERTICAL SECTIONS OF SALINITY(‰) ALONG P—S LINE.

FIGURE 5

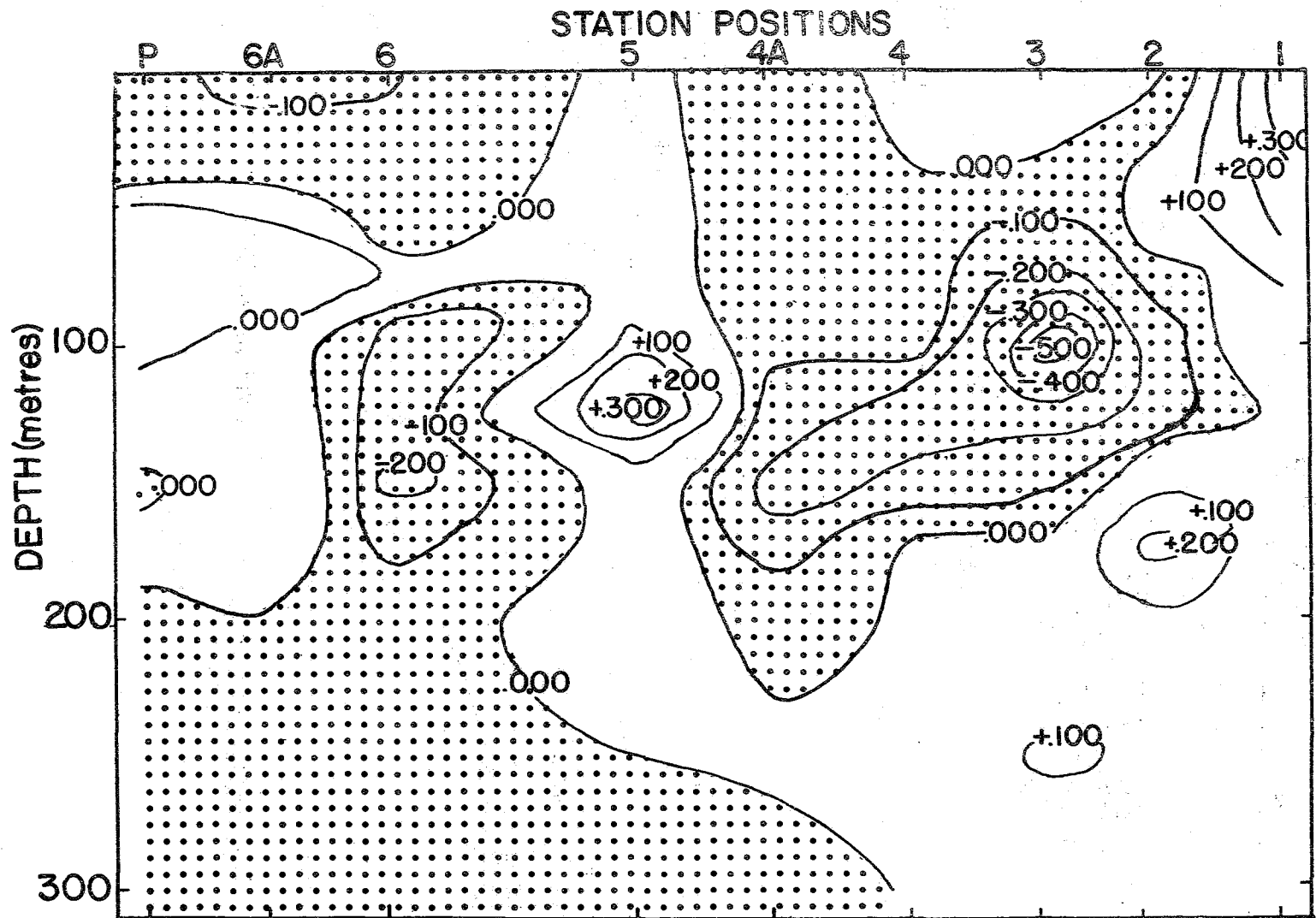

SALINITY(‰) CHANGE ALONG "P"—"S" LINE  
 (1 AUG.—6 AUG.)—(28 JUNE—2 JULY)

FIGURE 6

*A. W. H. Needham*

FISHERIES RESEARCH BOARD OF CANADA  
Pacific Oceanographic Group  
Nanaimo, B. C.

Circular 1962-20  
July 25, 1962

Oceanographic observations from Weather-ship  
C.C.G.S. St. Catharines. Cruise P-62-2, May 22-July 2, 1962

In addition to its meteorological duties the Canadian Coastguard Weather-ship "St. Catharines" carries out regularly scheduled oceanographic observations during each patrol at Station "P", and also en route to and from Station "P", (Fig. 1). This report is an immediate assessment of the regular oceanographic observations made during the voyage beginning May 22 and ending on July 2, 1962.

Temperatures between Swiftsure and Station "P"

En route to and from Station "P" continuous thermograph recordings of temperature are obtained from a depth of 3m. The dominant feature of the record during the outbound voyage was the irregular gradient. The net temperature decrease was about 3C°. However, pronounced minima occurred near stations 2 and 4A. The minima were of 1C° amplitude. By the time of the inbound voyage, 5 weeks later, the mean 3 m temperature had increased by about 2.5C°, the gradient had increased and only traces of the former minima remained.

Temperature changes between Stn. P and Swiftsure in the six weeks between the outward and inward passages (May 23-27 to June 28-July 2) are shown in Fig. 3. Warming occurred throughout the Section at depths less than 80 m. The amount of the change decreased uniformly from a maximum of 4 C° near 30 m depth to Stn. 1 to about 2C° at Station P. Between Stn. 3 and 6 the warming extended to at least 500 m depth, with the core centred near 300 m at Stn. 5. This suggests that the disappearance of the 3 m temperature minimum (see above) in the vicinity of Stn. 4A, was due to an intrusion of warm water. The cooling near the coast appears to be an intensification of a trend which has persisted to some degree since March, 1962.

The disappearance of the 3 m temperature minimum near Stn. 2 seems more likely to have resulted from a combination of seasonal heating and lateral mixing, or to the passing of a "cloud" of water rather than a persistent warming.

Variations of temperature observed at Stn. P (Fig. 4) during the cruise suggest that the cooling shown near Stn. P in Fig. 3 may be a reflection of relatively short term fluctuation, rather than a major cold intrusion or trend to cooling. This emphasizes the caution with which the plots of temperature change should be interpreted.

The most prominent feature of the vertical sections of temperature (Fig. 5 and 6) is the suggestion of a boundary at Stn. 5, to the west of which temperature gradients steepen markedly and a temperature inversion is observed. The boundary appeared to have intensified between the outbound and the inbound

*Continued*

voyage, partly due to the warming at Stn. 5.

#### Temperature conditions at Station P

Mean monthly thermograph temperatures (3 m) at Stn. P in April, May and June, 1962 (Fig. 7) were about  $0.5^{\circ}\text{C}$  higher than the 10-year means for these months. The mean temperatures for these months were also higher than the corresponding means in the previous two years.

(Fig. 8)

Near the end of May/temperatures above 100 m depth were warmer than those in the same period in the previous two years, but the difference had lessened by the end of June. Below 100 m depth temperatures tended to be warmer than those in the same period in 1961 (except in the minimum layer of the temperature inversion) but colder than those in 1960. (Fig. 9).

(Fig. 10)

The increase in temperature/which occurred above a depth of about 70 m between March and June 1962 may be attributed mostly to seasonal heating. However, the increase between 70 and 100 m and that between 200 and 500 m, during the same period can be due only to the movement of warmer water into the Stn. P region by currents or mixing.

Comparison of February-March and May-June, 1962 temperatures in the 100-200 m depth range is complicated by the presence of a temperature inversion. However, in June, the waters in the minimum temperature layer appeared to be colder and those in the maximum temperature layer were warmer.

The temperature inversion appeared in all bathythermograms at Stn. P, during this cruise, and occurred at greater depths than during the February-March period of observation.

Since the oxygen concentration in the minimum temperature layer of the inversion was less than that in the previous winter's upper layer, immediately above it, it may be inferred that the minimum was not formed by cooling during the winter. If this had been the case, a sharp oxygen maximum should have been associated with the temperature minimum. If mixing had been sufficient to reduce the oxygen content in a temperature minimum recently formed by winter cooling one might expect that the minimum would be modified or erased. The difference between the oxygen content in the temperature minimum and in the water immediately above it suggests that if mixing alone was responsible for the decrease in oxygen content, the original temperature minimum may have been too cold to have been formed near Stn. P.

During the May-June 1962 period of observations, temperatures tended to increase from the surface to 50 m depth, but showed little if any net change below 50 m.

The depth of the top of the thermocline decreased from about 60 m near the end of May, to about 20 m near the end of June. This may be a consequence of the seasonal increase in stability and decrease in mixing intensity.

Although two regions of strong gradient (30-40 m and 100-120 m) were usually present, the thermocline was essentially continuous from its upper limit to a depth of about 120 m. During the same period in 1961 the bottom of the thermocline occurred at a depth of about 75 m, as it usually did in June 1960. However, in 1960 the thermocline extended to 120 m when a tempera-

ture inversion was present.

#### Primary production

The mean primary production was  $140 \text{ mg C/m}^2/\text{day} \pm 25\%$ , somewhat less than previous observations would lead one to expect at this time of year.

#### Zooplankton

Zooplankton was abundant throughout the cruise and catches in both horizontal and vertical tows consisted mainly of copepods.

#### Fishing

A total of about 300 salmon were caught. During the first week on Station sockeye were predominant. Thereafter coho were the dominant catch. Almost half the salmon were caught in a single 7-day period. The fish were feeding heavily on a Loligo - like squid. Very few empty stomachs were observed. In the last week of June the salmon catch declined but was replaced by pomfret. A total of about 70 pomfret were taken, the mean weight of which was about  $2\frac{1}{2}$  - 3 lbs, 1 lb greater than during July 1961.

#### Miscellaneous

Feeding sperm whales were not uncommon. One sea lion and several small fur seal were sighted. On several occasions a pair of longtailed jagars were observed, apparently hunting petrels.

C.D. McAllister

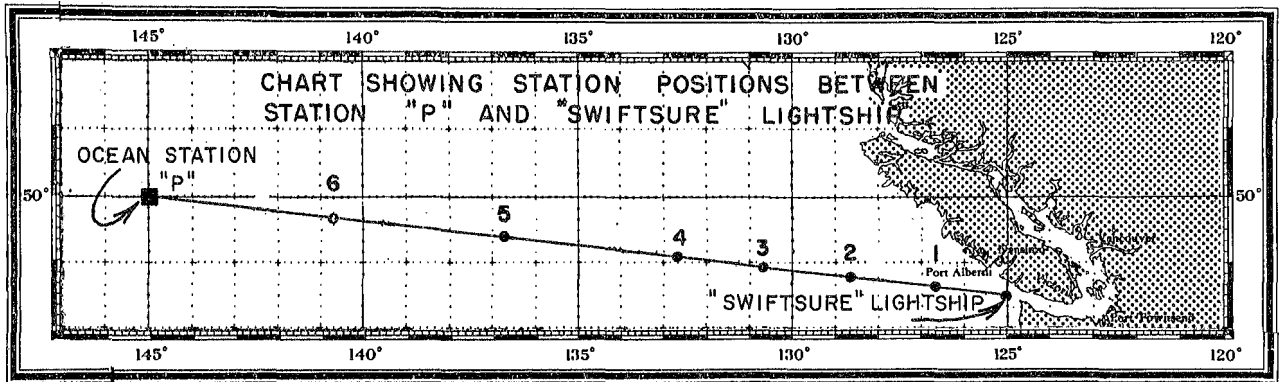

Figure 1.

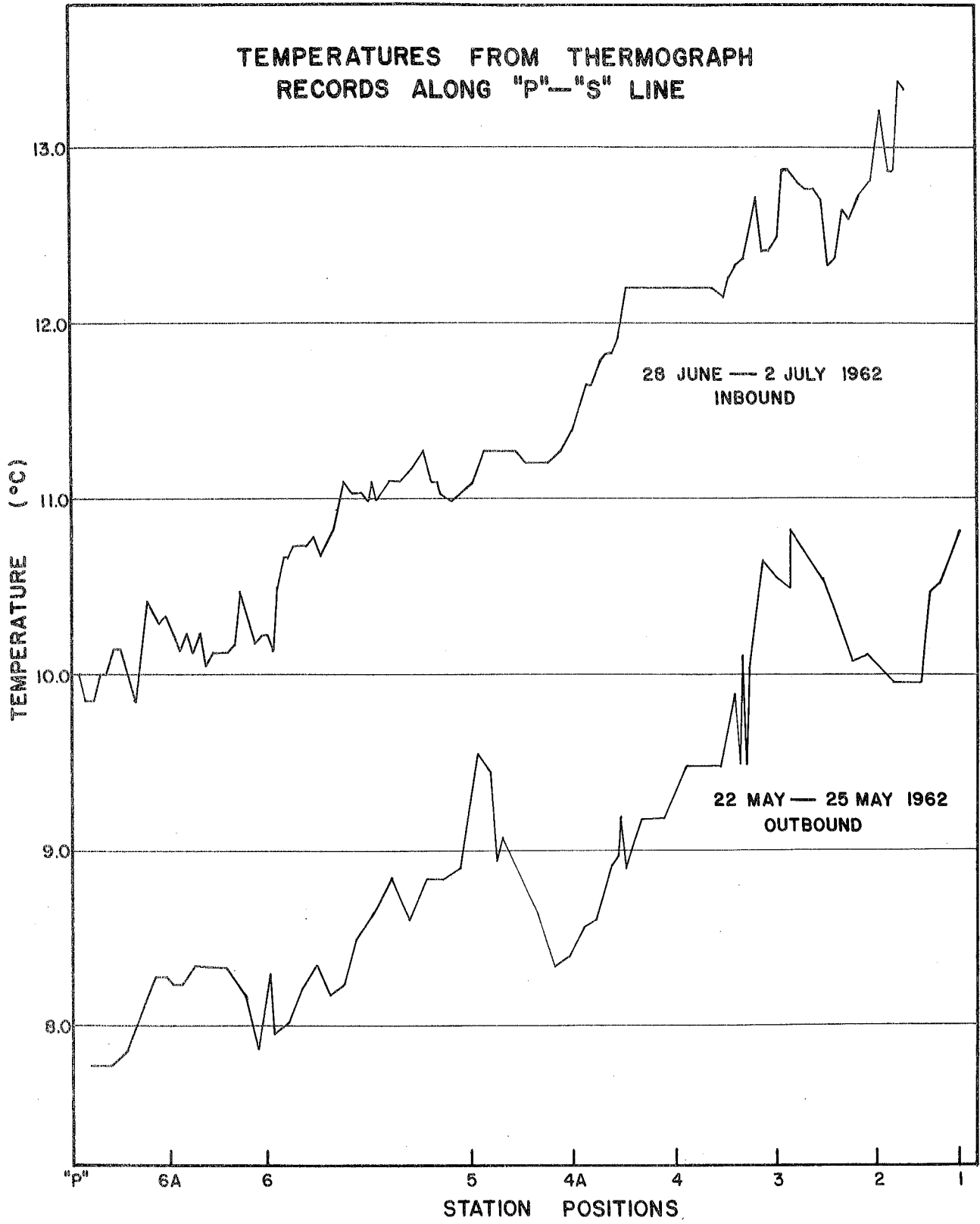

Figure 2

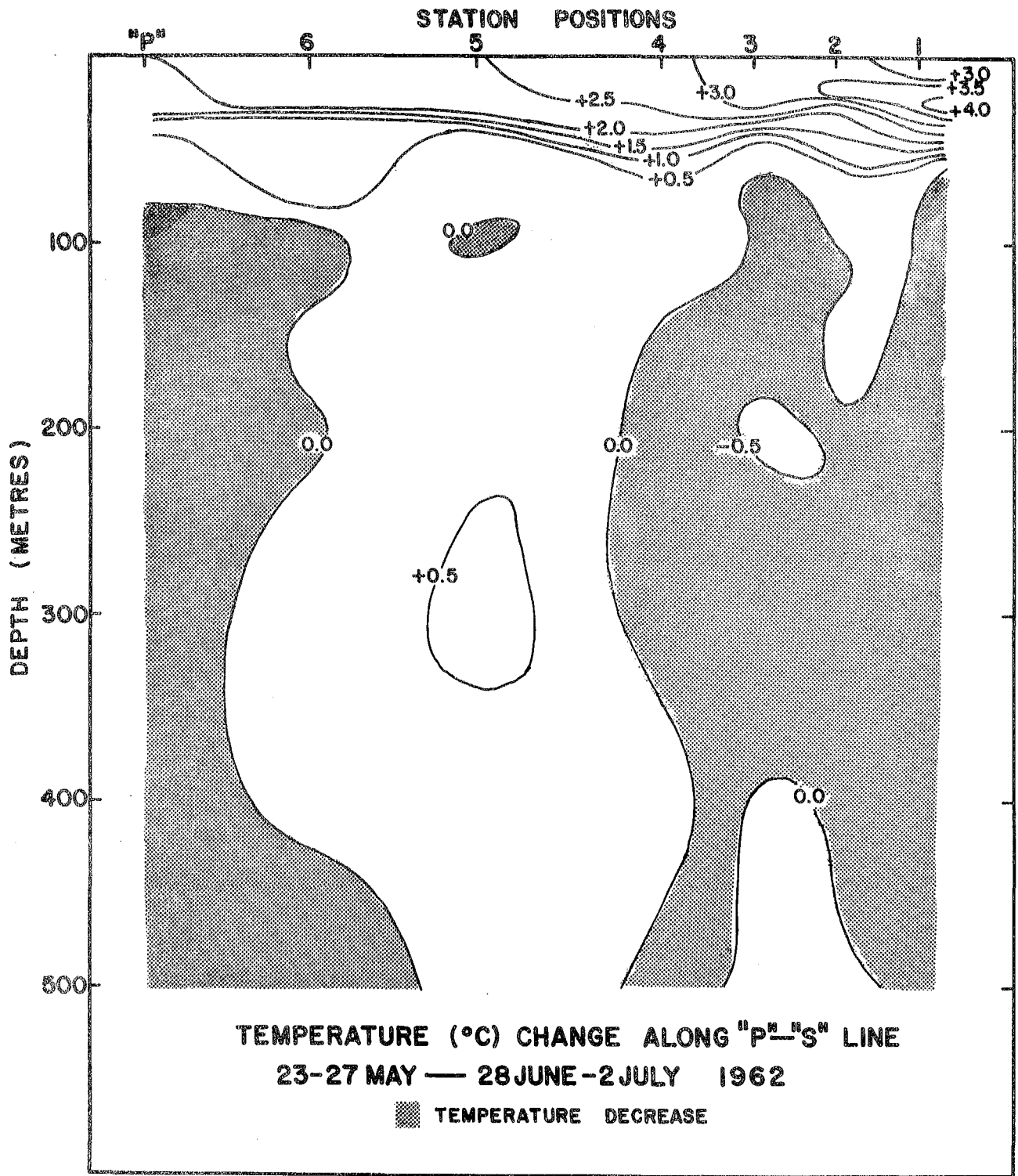

Figure 3

# TEMPERATURES AT SELECTED DEPTHS STATION "P" 1962

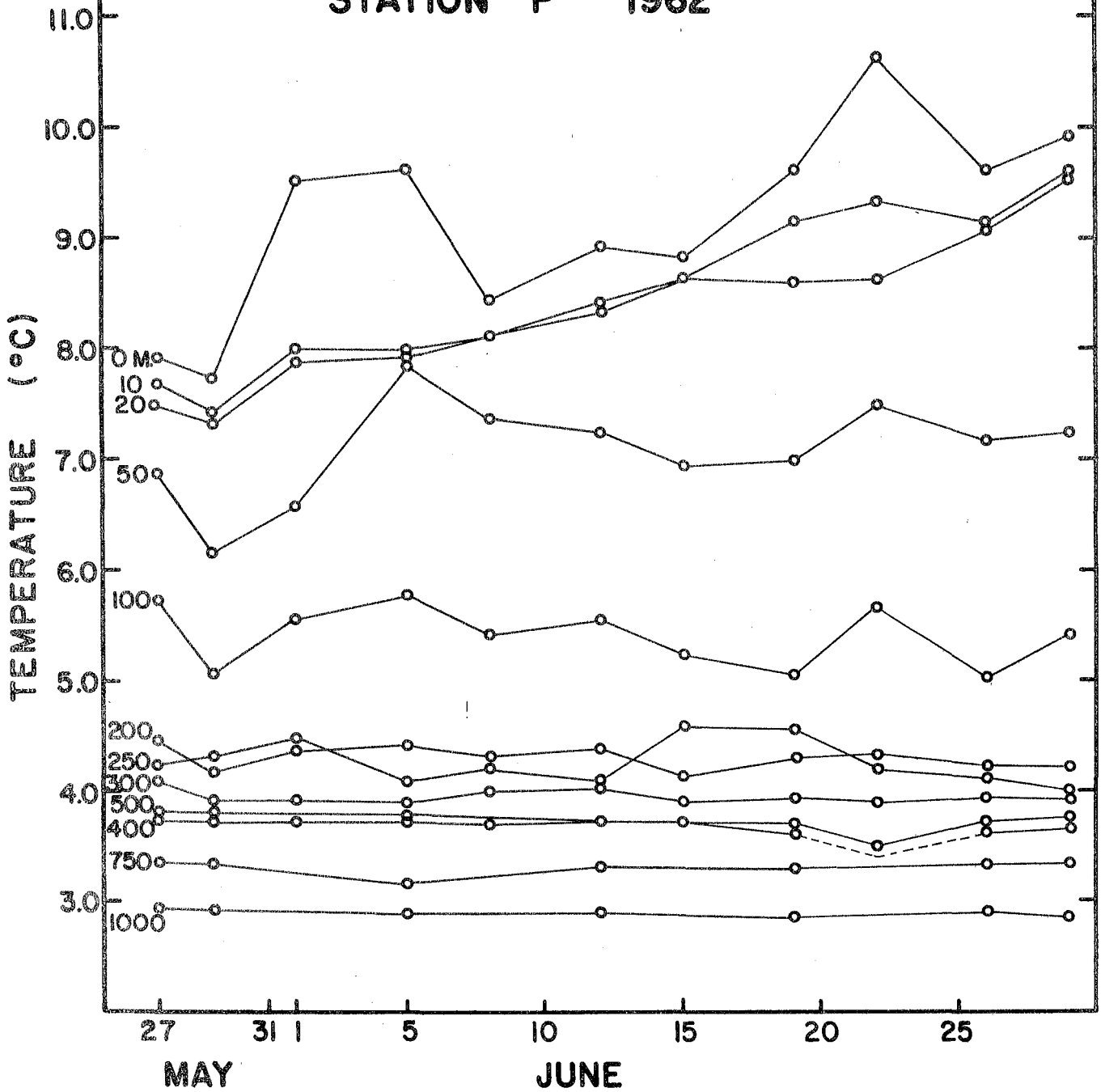

Figure 4

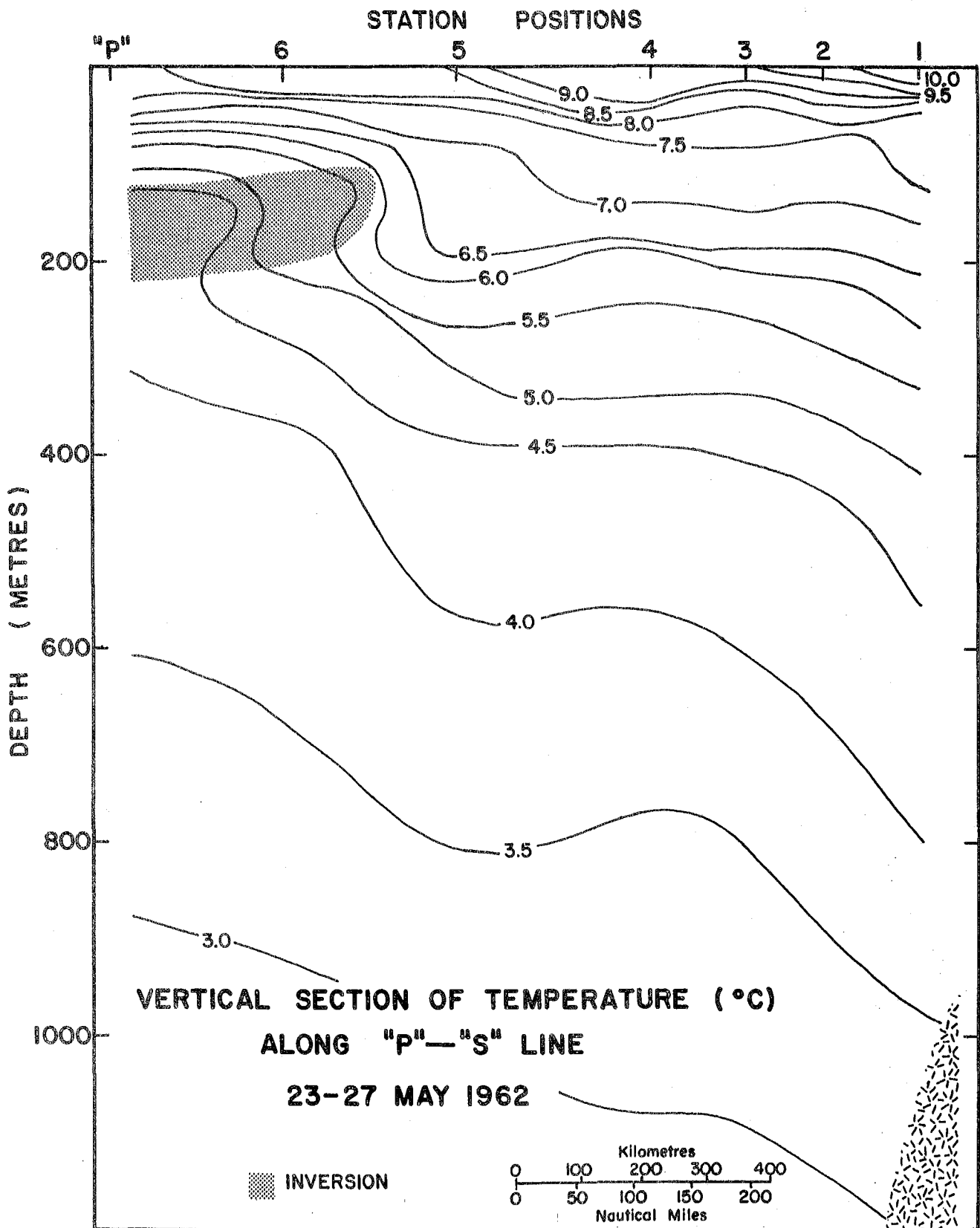

Figure 5

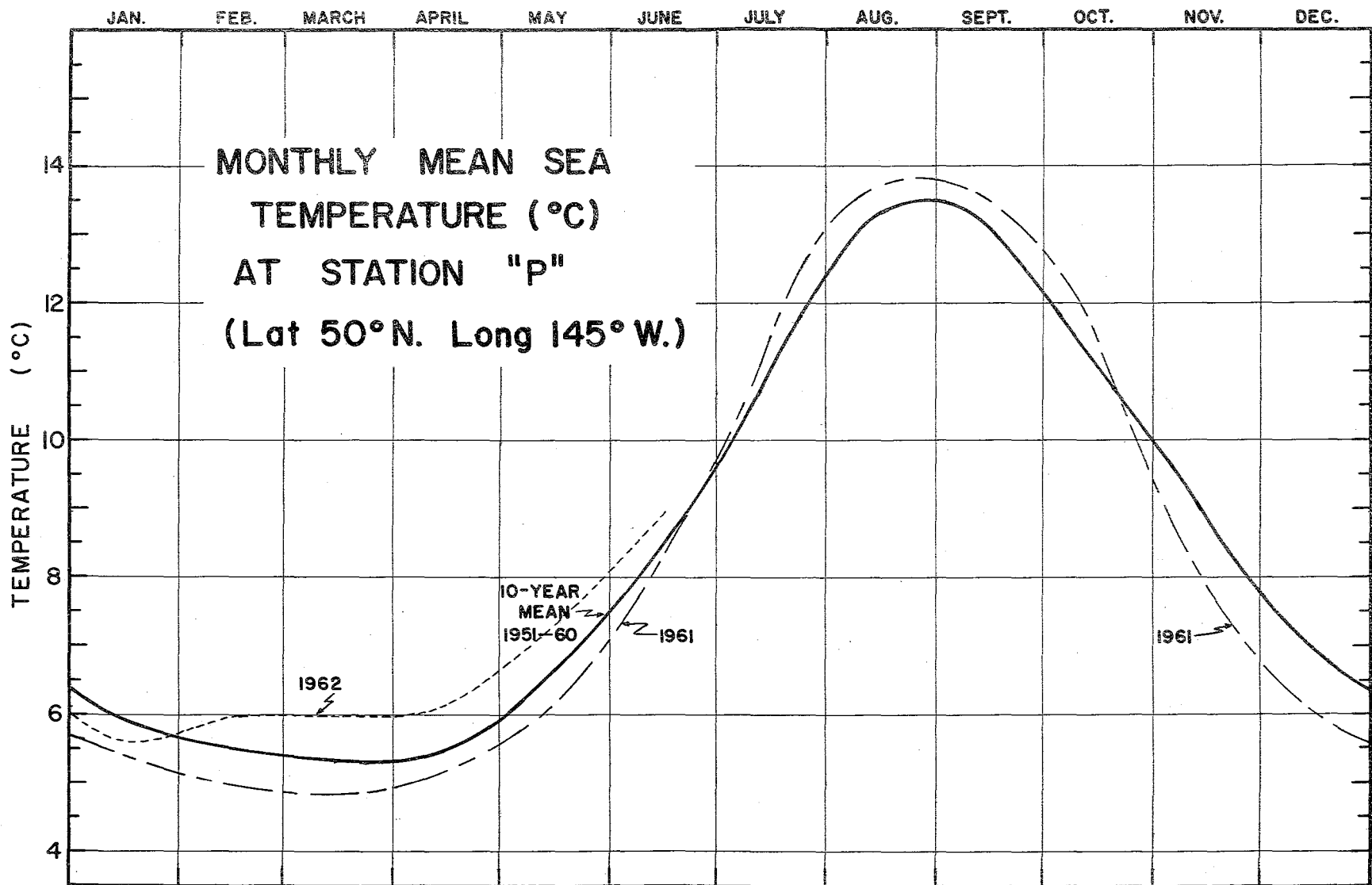

Figure 7

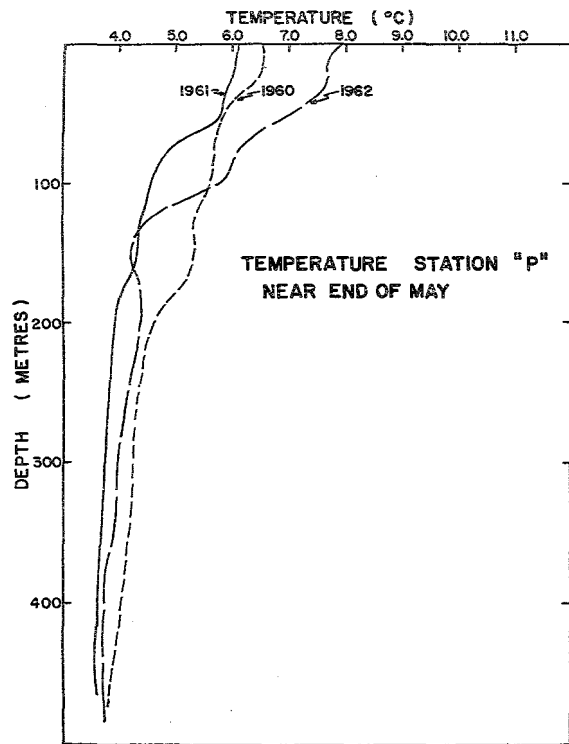

Figure 8

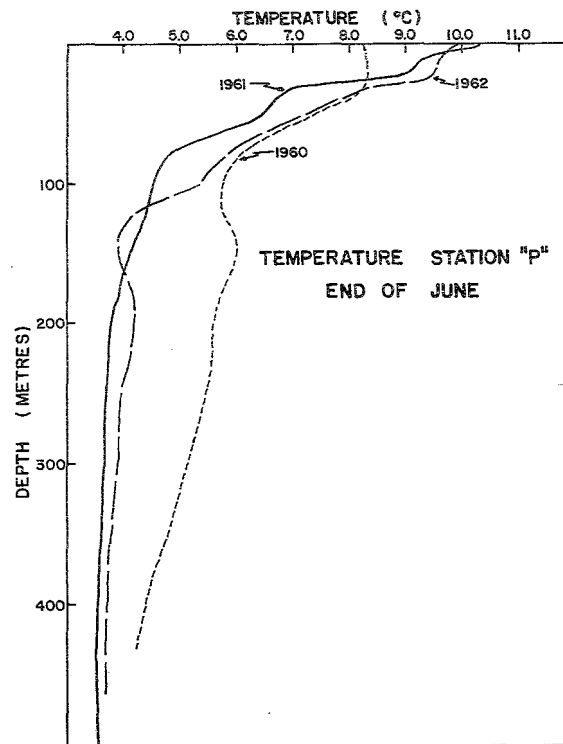

Figure 9

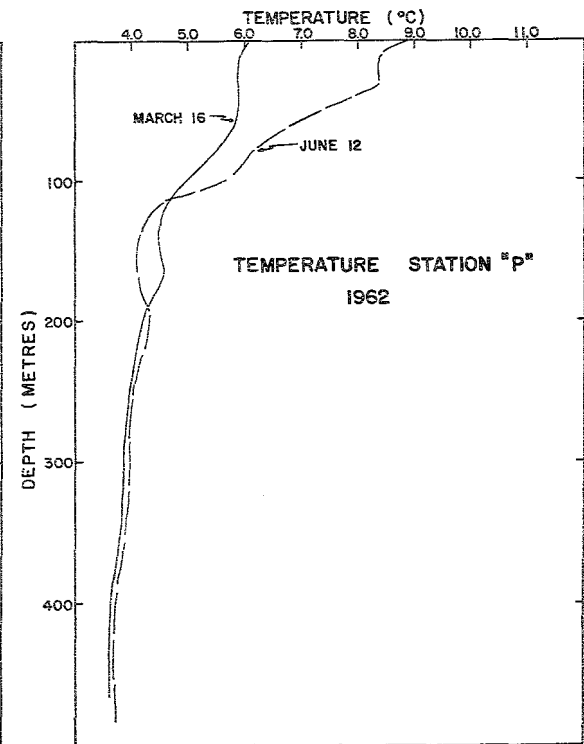

Figure 10

FISHERIES RESEARCH BOARD OF CANADA

Pacific Oceanographic Group  
Nanaimo, B. C.

Circular 1962 - 21  
July 31, 1962

B. C. Coastal Seawater Temperatures  
April, May, June, 1962

Introduction

A weekly report of the daily seawater temperatures observed at four lightstations - Triple Island, McInnes Island, Entrance Island and Amphitrite Point - is broadcast on Wednesday mornings from radio station CBU. A report of the monthly mean seawater temperature (computed from the daily observations between the 1st and 27th) is received from three other lightstations, at Langara Island, Cape St. James and Kains Island. These monthly temperature reports are transmitted to the San Diego Biological Laboratory of the U. S. Bureau of Commercial Fisheries for use in their monthly sea-surface temperature charts of the Eastern Pacific Ocean.

This circular is a summary of these reports for the three months of April, May and June, 1962.

The monthly mean temperature data are tabulated in Table I, along with various anomalies and the classification indices. These indices, recorded in the last column of the Table, represent the number of  $\frac{1}{2}$  standard deviation units there are in the anomaly between the monthly mean temperature and the 10-year grand monthly mean temperature; a positive (+) index indicates a warmer anomaly, a negative (-) index a colder anomaly.

Seawater temperatures along the ocean coast

If the four ocean coast stations - Langara, Cape St. James, Kains and Amphitrite - are considered as a unit, it can be noted that a colder than average anomaly has been increasing in scope during the three months. Cape St. James' reports show a significant anomaly of -2; the negative anomalies at the other three stations indicate a trend. In the months of May and June, the 1962 monthly mean temperatures were about 2F° colder than in 1961.

The seasonal warming-up rate is at its greatest during these three months. At Cape St. James, the monthly rate increased from 1.5F° to 2.5F°. Unfortunately, observations were <sup>not</sup> made at Langara during June, due to a misunderstanding between relief observers, but the rate of warming-up in June would probably be 2 $\frac{1}{2}$ F°. At Kains Island, the rate was 3F° in June, but at Amphitrite it dropped to a low 3/4F°. The colder June temperatures at Amphitrite are possibly the result of a large colder-than-average body of ocean water that has been building up off the Washington - Oregon coast in the past two months.

Seawater temperatures in northern B. C. coastal waters

Monthly mean temperatures for Triple Island have been colder than average

for the three-month period, and the 1962 - 1961 anomaly has been a negative one of  $2\frac{1}{2}$  to  $3\frac{1}{2}F^{\circ}$ . A similar colder-than-average condition is noted in the reports for McInnes Island, but probably not as cold as at Triple.

Seawater temperature conditions in southern B. C. coastal waters

Reports for Entrance Island and Departure Bay indicate <sup>normal</sup> monthly mean temperatures for the three months, with a slight colder-than-average trend apparent in the May reports. This is possibly due to the fact that May air temperatures were 2 to  $5F^{\circ}$  below normal on the B. C. coast. The 1962-1961 anomaly was insignificant in April, but increased to a negative  $1\frac{1}{2}$  to  $2F^{\circ}$  in the other two months.

General Summary

B. C. coastal temperatures were normal during April; were colder than average in May; and were still slightly colder than average on the ocean and northern coasts in June, but had returned to normal in the Strait of Georgia.

H.J. Hollister

Table I. Monthly means and anomalies of seawater temperature (°F)  
April, May, June, 1962.

Station	April 1962	April - March	Apr. diff. 1962-1961	Apr. 1962 - 10 yr. av'ge	Classific'n/ Stnd. dev'n
Langara I.	44.5*	+2.3	-0.7	+0.0	+0/1.5
Cape St. James	44.6	+1.6	-3.3	-1.5	-2/1.1
Triple I.	43.9	+2.1	-2.3	-0.9	-1/1.3
McInnes I.	44.8	+2.3	-2.4	-0.9***	-
Kains I.	47.8*	+2.4	-1.5	+0.2	+0/1.0
Amphitrite Pt.	49.0	+3.3	-0.1	+0.5	+0/1.2
Entrance I.	48.3	+3.6	+0.2	+0.0	+0/0.6
Departure Bay	48.6	+4.3	+0.3	-0.1	-0/1.2

Station	May 1962	May - Apr.	May diff. 1962-1961	May 1962- 10 yr. av'ge	Classific'n/ Stnd. dev'n
Langara I.	46.0*	+1.5	-2.0	-1.0	-1/1.3
Cape St. James	46.3*	+1.7	-2.5	-1.3	-3/0.7
Triple I.	46.2	+2.3	-3.6	-1.6	-2/1.4
McInnes I.	47.8	+3.0	-2.8	-1.3***	-
Kains I.	49.4*	+1.6	-2.3	-0.8	-1/1.1
Amphitrite Pt.	51.1	+2.1	-1.1	+0.2	+0/1.8
Entrance I.	53.1	+2.8	-1.3	-1.1	-1/1.7
Departure Bay	52.9	+4.3	-1.4	-1.8	-1/1.9

Station	June 1962	June - May	June diff. 1962-1961	June 1962- 10yr. av'ge	Classific'n/ Stnd. dev'n
Langara I.	No observations		-	-	-
Cape St. James	48.9*	+2.6	-1.4	-1.7	-2/1.5
Triple I.	49.8	+3.6	-2.8	-2.1	-2/1.8
McInnes I.	51.7	+3.9	-2.3	-0.6***	-
Kains I.	52.7*	+3.3	-1.8	-0.1	-0/1.4
Amphitrite Pt.	51.9	+0.8	-1.4	-0.6	-1/1.8
Entrance I.	58.6	+5.5	-2.1	+0.1	+0/2.5
Departure Bay	59.5	+6.6	-1.9	+0.2	+0/2.5

\*1-27 mean

\*\*\*8-yr. av'ge.

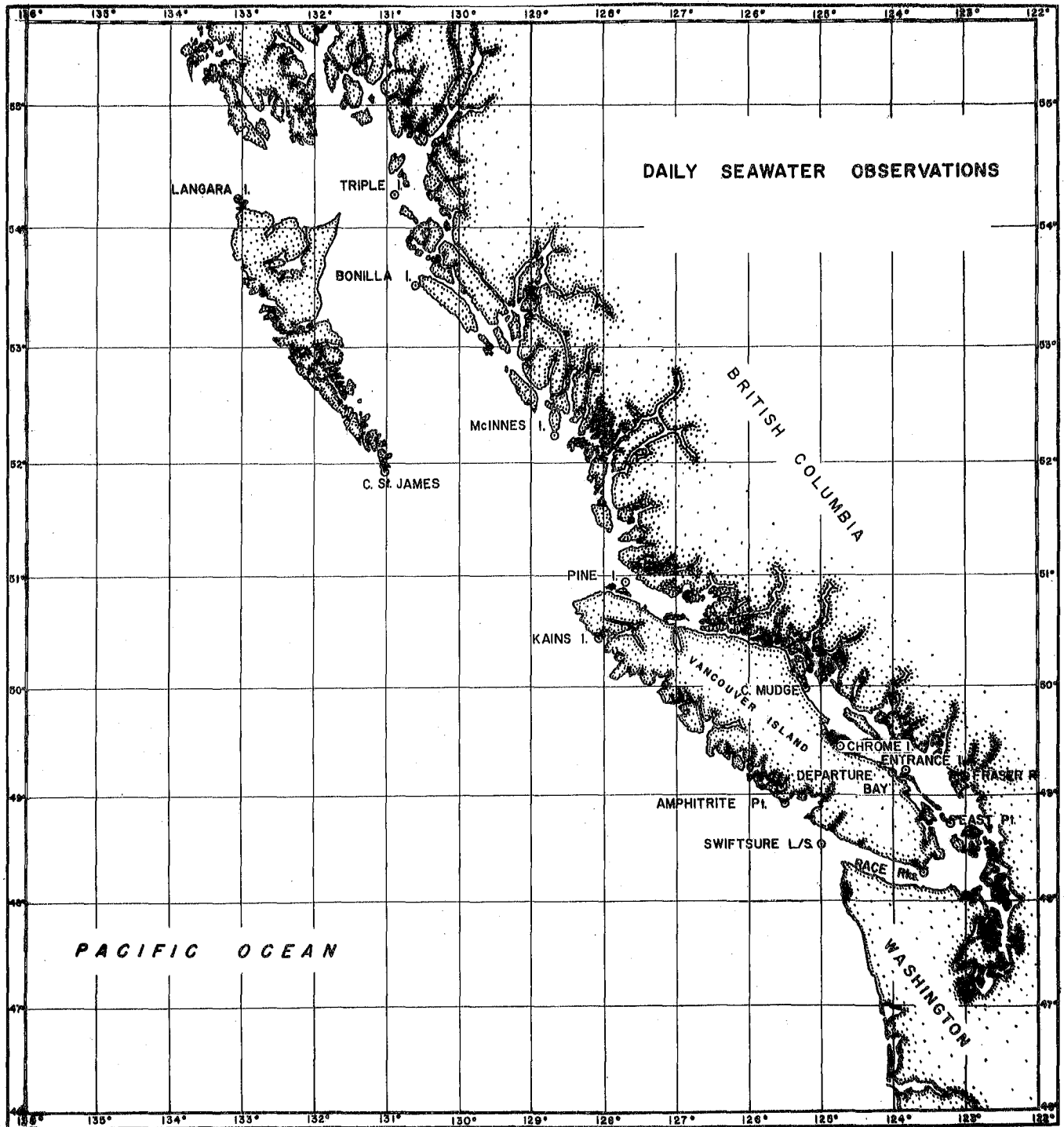

Figure 1. Location of stations making daily seawater observations.

FISHERIES RESEARCH BOARD OF CANADA  
Pacific Oceanographic Group  
Nanaimo, B. C.

CIRCULAR 1962-22

Canadian Oceanographic Research in the Subarctic Pacific Region  
during 1962

by A. J. Dodimead

October, 1962.

Canadian Oceanographic Research in the Subarctic Pacific Region  
during 1962

by A. J. Dodimead

Oceanographic research in the Subarctic Pacific during 1962 has consisted of:

1. A two-ship survey of the eastern Subarctic during the early summer period (May 25 to July 5).

Two vessels, CNAV "Oshawa" and "Whitethroat" occupied 218 stations (Fig. 1). On the continental shelf, observations of temperature, salinity and dissolved oxygen were made to near the bottom. In the oceanic area, observations were made to 1200 metres depth, except at "special" stations where samples were obtained to the bottom or 4000 metres depth, which ever was least. Bathythermograph, secchi disc and plankton (vertical and horizontal tows) were also made throughout the area. The period of the survey, the station positions and the observations are almost identical to those of the previous year. The data have been published.

2. Oceanographic observations at Ocean Station "P" and enroute to and from the station during alternate six-week periods (February 27-April 16; May 22-July 2; July 31-September 17; and October 23-December 10) aboard CCGS "St. Catharines". Bathythermograph observations were maintained aboard CCGS "Stonetown" during the other periods.

Observations were similar to those in previous years. Data to August have been published.

3. Presentation of weekly charts of sea surface temperature, depth to top of seasonal thermocline, magnitude ( $\Delta T$ ) of the seasonal thermocline, and depth to the bottom of the thermocline, by the Canadian Oceanographic Information Service, Esquimalt, B.C.

These charts are compiled from bathythermograph data from several Canadian and United States services, involving oceanographic, fisheries and naval vessels from both countries. Additional sea surface temperature data are obtained in weather reports from ships in transit.

4. Evaluation of an Airborne Radiation Thermometer (ART) as an operational instrument for measuring sea surface temperatures.

Patrols by the Royal Canadian Air Force were made twice weekly off the Canadian coast throughout the summer months.

5. Monthly presentation of atmospheric pressure distributions and transports computed from wind stress in the northern Pacific. These charts now cover the period 1955 through June 1962.

6. Coastal monitor surveys (3). Data for the first two surveys have been published.

7. Daily observations of surface temperature and salinity at 14 lightstations.

8. Completion of Chapter VI - Review of Oceanography of the Subarctic Pacific Region by A.J. Dodimead, F. Favorite and T. Hirano.

#### Oceanographic conditions, 1962

The data from the early summer cruise are presented in the same manner as in previous reports.

The distributions of temperature and salinity at the bottom of the upper zone are presented in Fig. 2 and 3 respectively. These are considered to be a remnant of, and to represent the isothermal, isohaline conditions that existed in the upper zone (75 to 125 metres depth) during the later winter period (March).

West of long. 145° W, the water was warmer (about 1 C°) than observed during 1961 and almost as warm as during 1958. The 10 metre temperatures at Ocean Station "P" for late winter (January - March) are shown in Fig. 4. These are representative of the temperature in the isothermal upper zone. Annual differences at Ocean Station "P" generally apply to most of the mid-ocean eastern Subarctic.

Off the British Columbia coast, opposite anomalies occurred. Water, warmer than 7° C at the bottom of the upper zone was not as extensive as during the preceding years (1958-1961) (Fig. 5). However, the water was warmer than during 1955 through 1957. The daily seawater observations suggest that conditions were slightly below average in March, 1962.

Salinities at the bottom of the upper zone (Fig. 3) were, in general, slightly less (0.1 to 0.2 ‰) than observed in 1961.

By mid-June, the surface waters above the seasonal thermocline (to approximately 30 metres depth) had attained temperatures and salinities shown in Fig. 6 and 7 respectively.

Comparison of these temperatures with those observed in mid-June 1961 show that in mid-ocean (south of lat. 55° N and west of long. 135° W),

the surface waters were still warmer in 1962 (Fig. 8). The greatest difference (3 to 4 C°) occurred in the southern part of the region. Here, temperatures in this period were also greater than the 30-year mean.

Around the coast, the water was slightly colder in June, 1962 than in 1961 (Fig. 8). This anomaly is confirmed in the daily seawater observations, which also indicate that near-average conditions prevailed (tendency to be slightly above average along the Canadian coast).

Surface salinities (Fig. 7) were still lower (about 0.1 to 0.2 ‰) in June 1962 compared to June 1961.

Monthly mean sea surface temperature charts and anomalies compared to the previous year and a 30-year mean are published by the Bureau of Commercial Fisheries Biological Laboratory, San Diego, California. Mean sea surface temperatures for August 1962 are shown in Fig. 9. Compared to August 1961, the water was now slightly colder in August 1962 (maximum difference of 1 C°) at least south of lat. 55° N (no data north of lat. 55° N). Data from Ocean Station "P" and from the lightstations showed similar anomalies and also indicated that near-average conditions prevailed throughout most of the area.

The temperature distribution on the surface of salinity - 33.8 ‰ (Fig. 10) is representative of conditions in the non-seasonal zone below the halocline. Yearly variations in this distribution are indicative of changes in the circulation of the lower zone water. Warm water, greater than 6.5° C along the Canadian coast extended slightly further north in 1962 than during 1959 through 1961 (Fig. 11). This change is opposite to that in the upper zone waters in this area.

Data from Ocean Station "P" indicate that there was very little change in the lower zone waters (between 200 and 500 metres depth) from mid-March to mid-June. It is reasoned that the lower zone conditions were established early in the year throughout the area and remained much the same, at least till the end of summer.

The surface circulation deduced from the geopotential topography (Fig. 12, 0/1000 decibars) shows similar features as in other years. However, off the Canadian coast, the circulation appeared to be relatively weak.

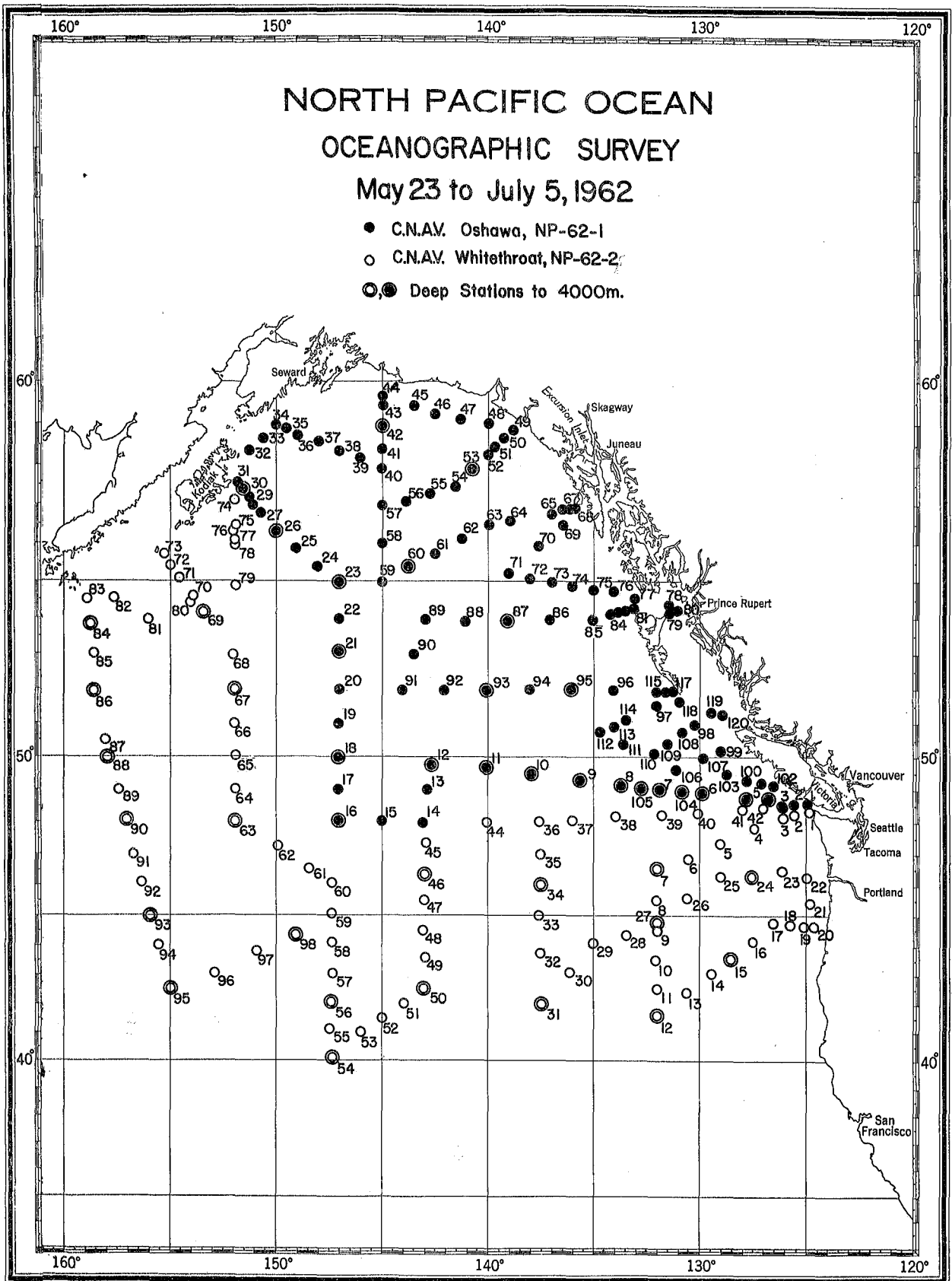

FIG. I

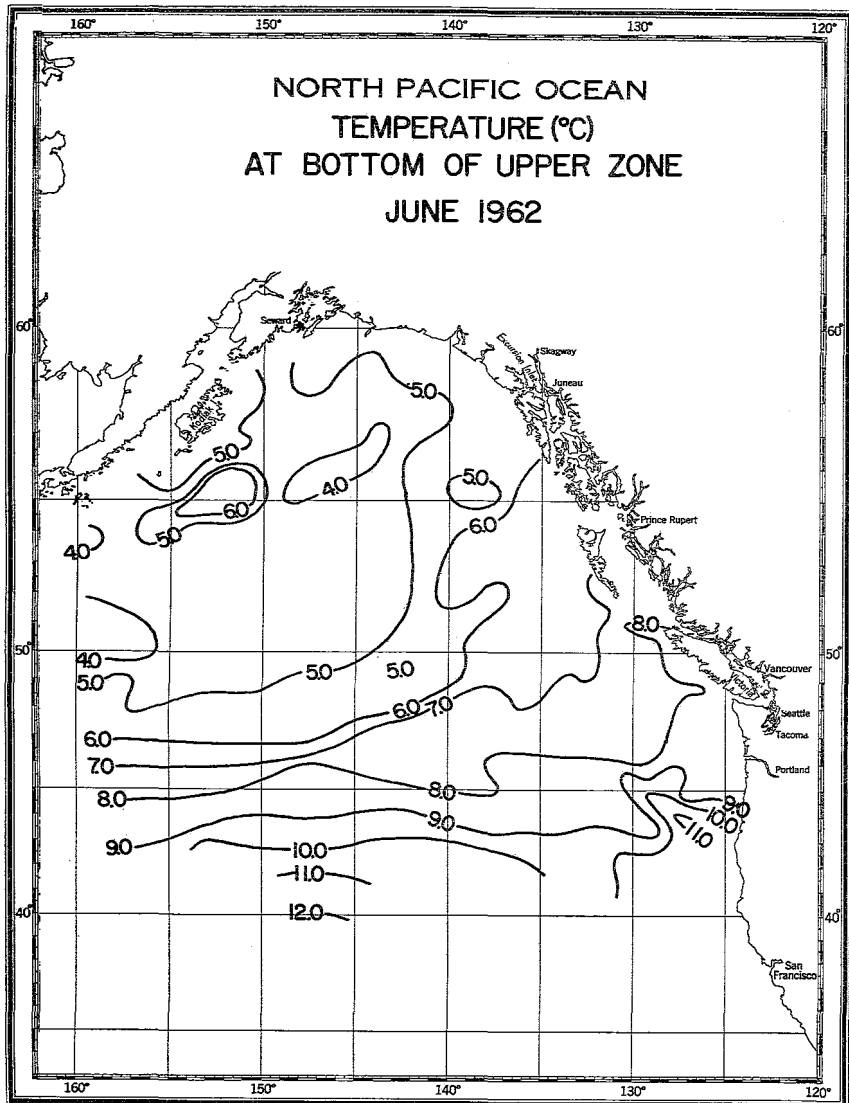

FIG. 2

S-148A

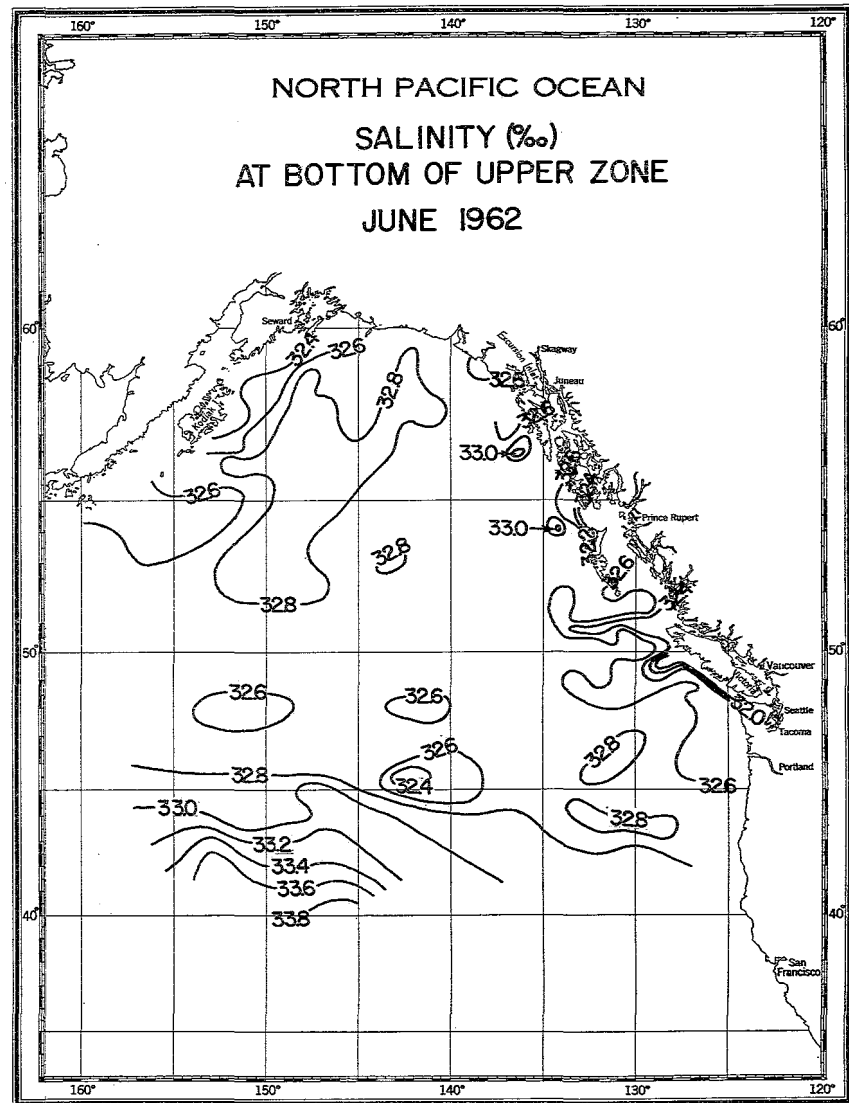

FIG. 3

S-148A

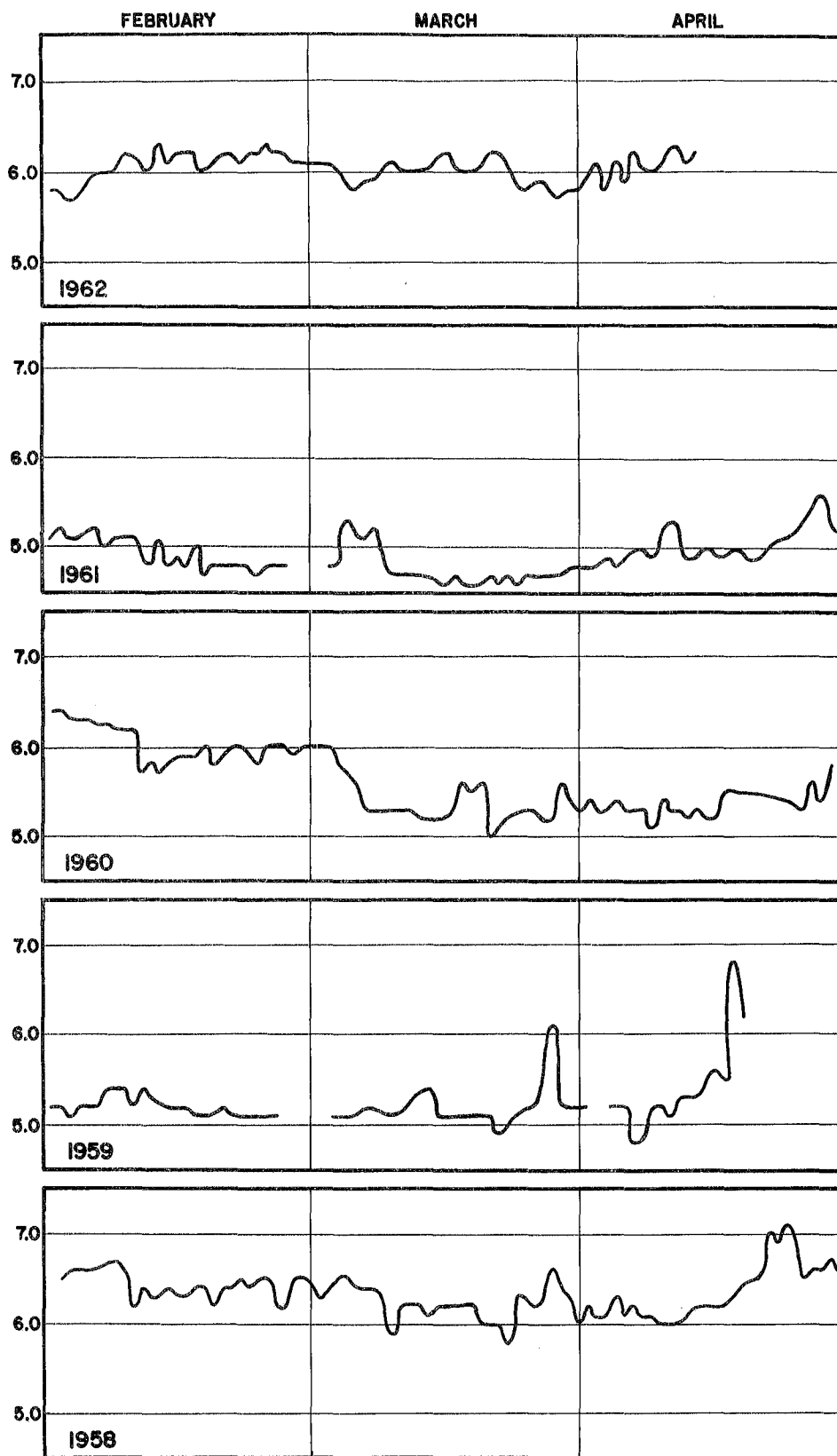

Fig. 4 Temperatures at 10 metres depth at Ocean Station "p"



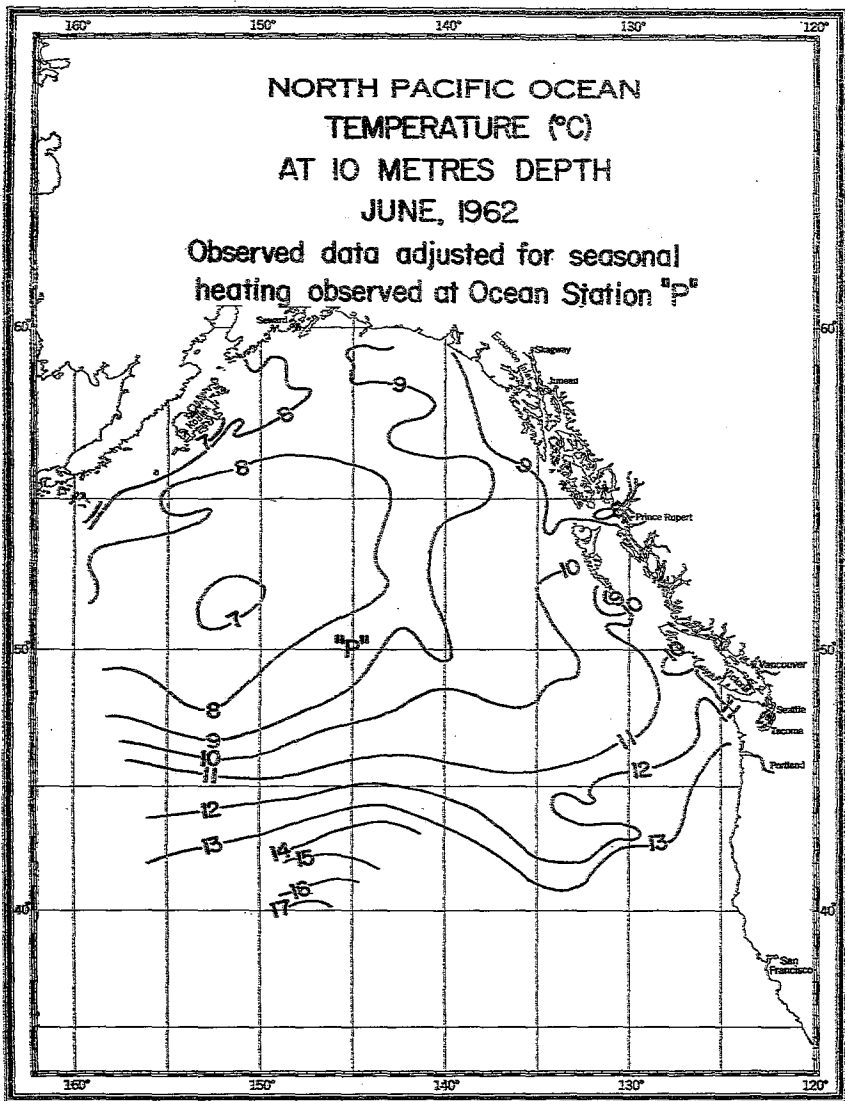

FIG. 6

S-148A

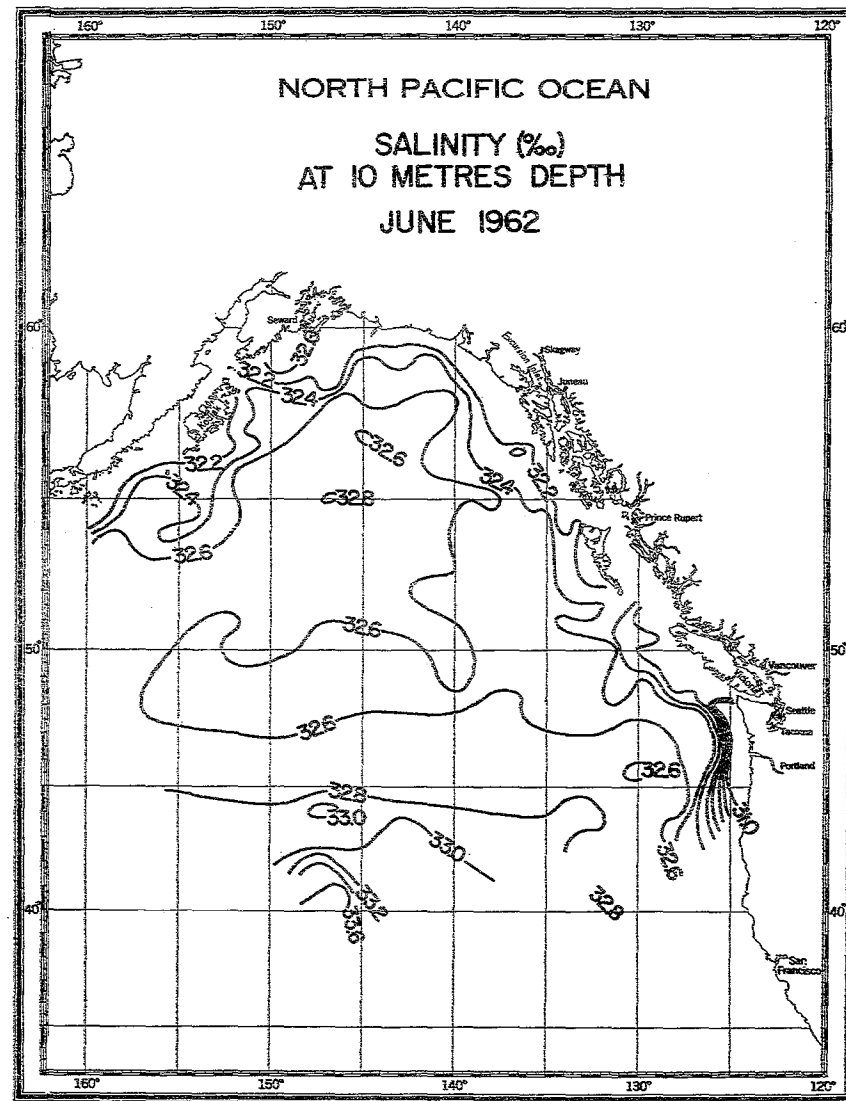

FIG. 7

S-148A

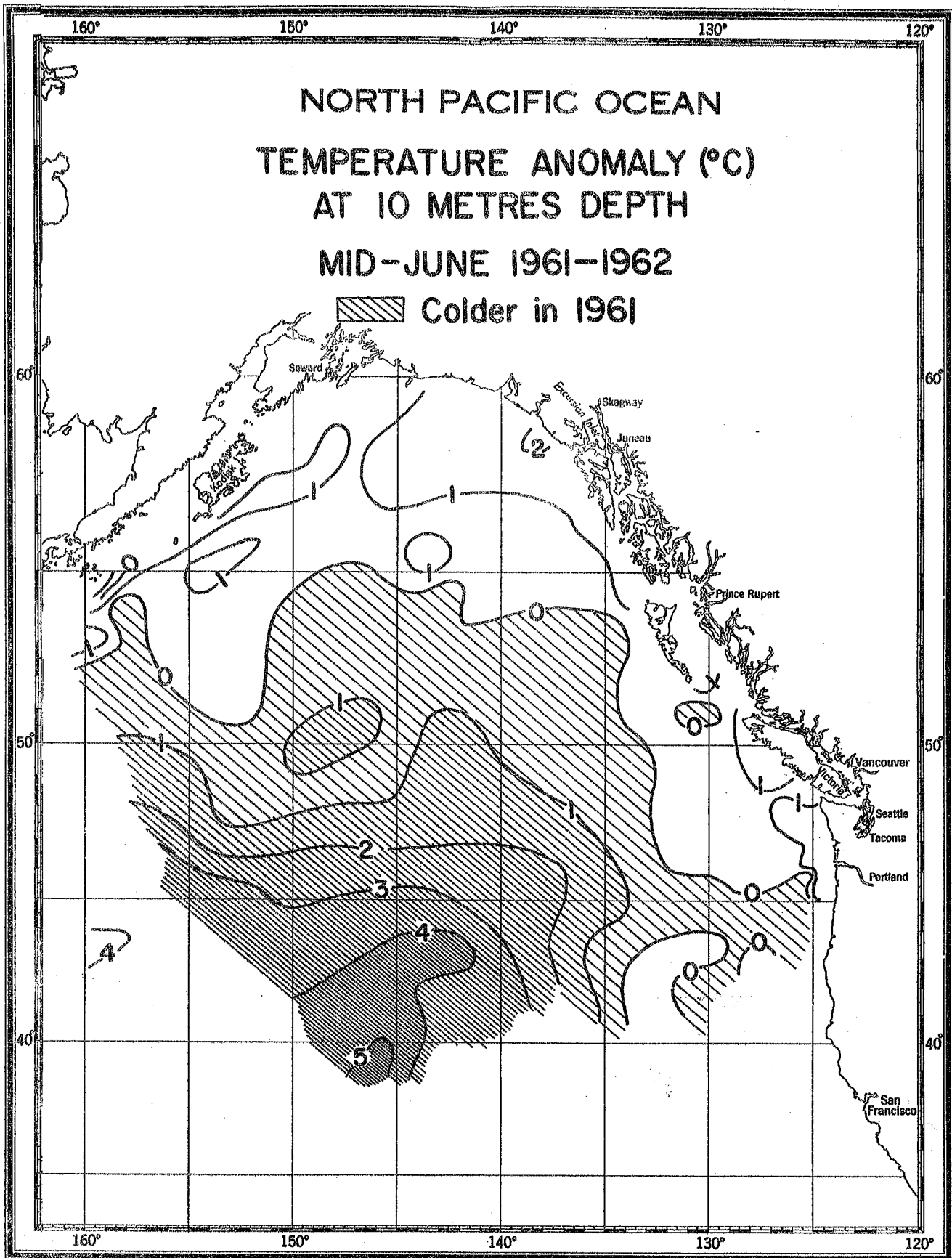
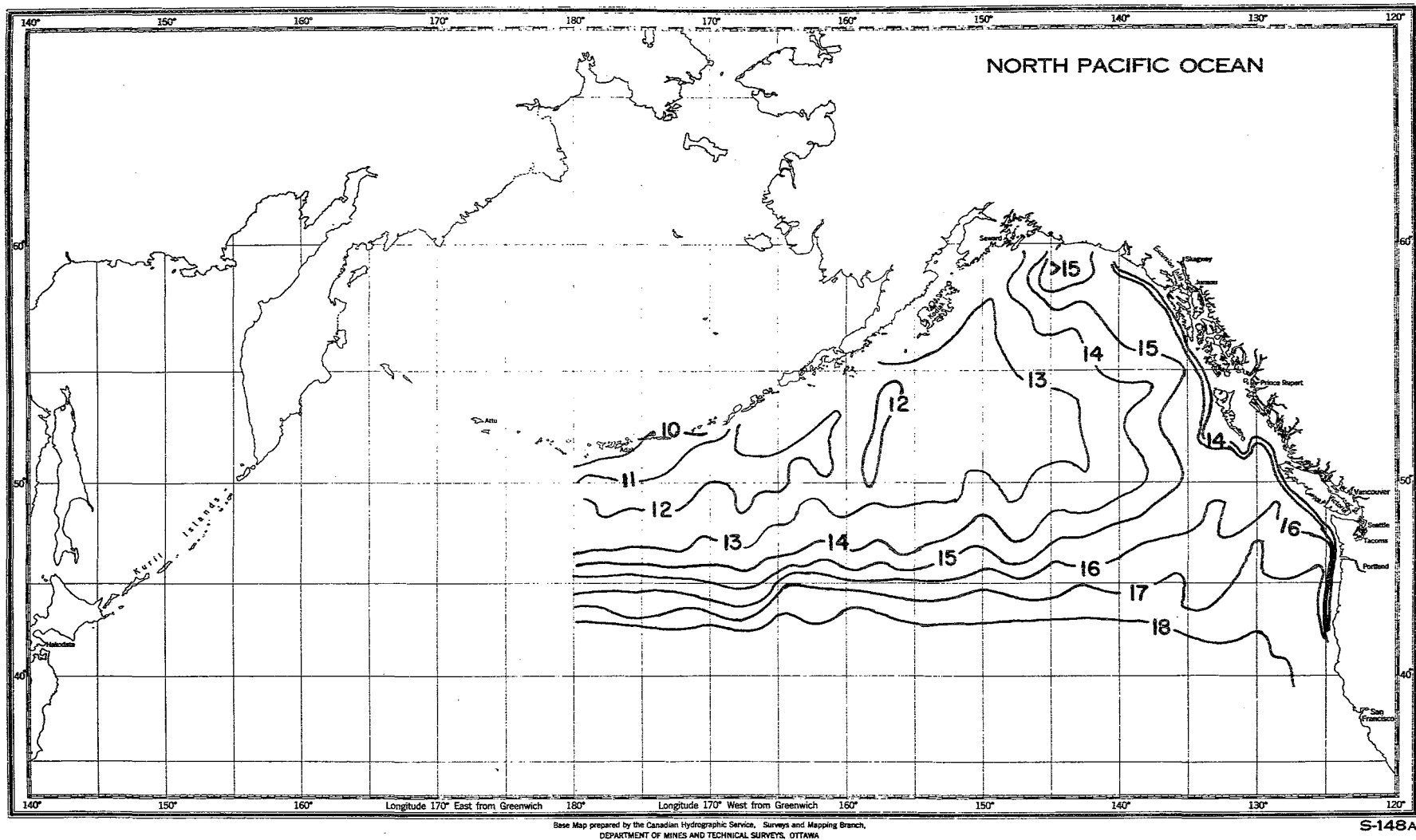

FIG. 8

S-148A



**FIG. 9. MEAN SEA SURFACE TEMPERATURES (°C) AUGUST 1-31, 1962. (adapted from charts published by Bureau of Commercial Fisheries Biological Laboratory, San Diego, California)**

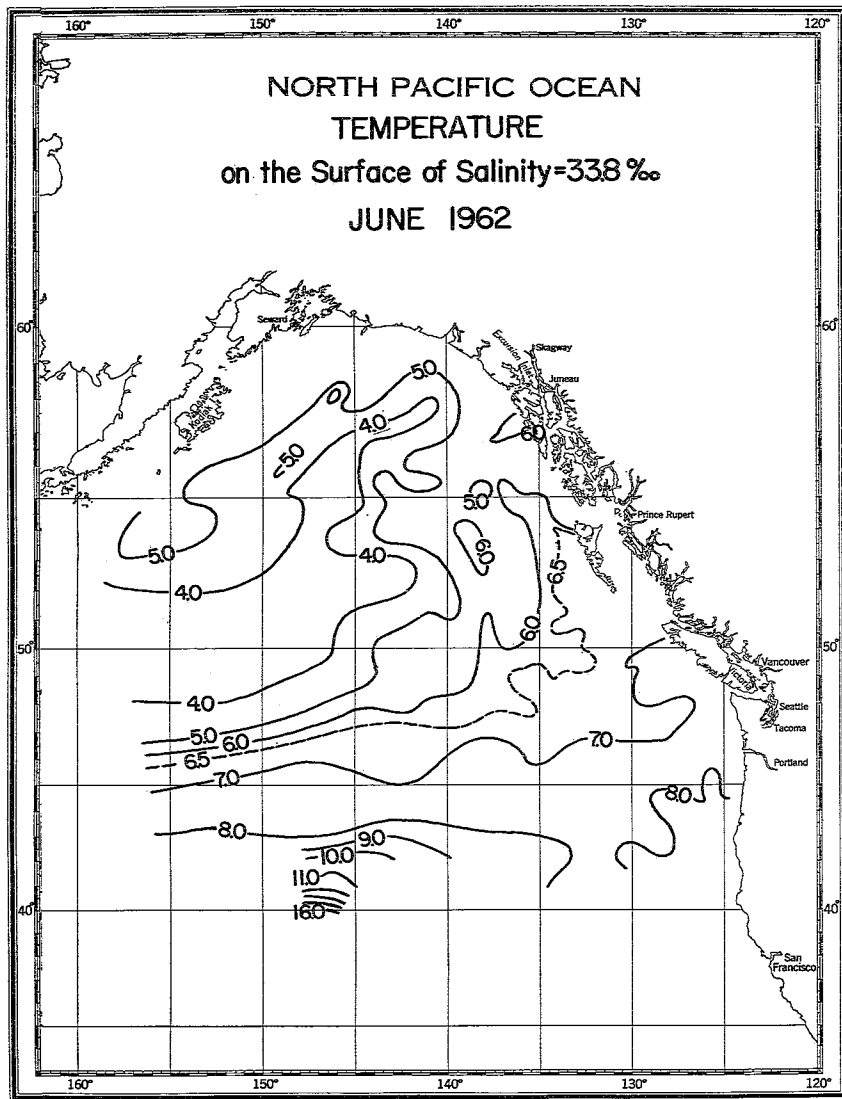

FIG. 10

S-148A

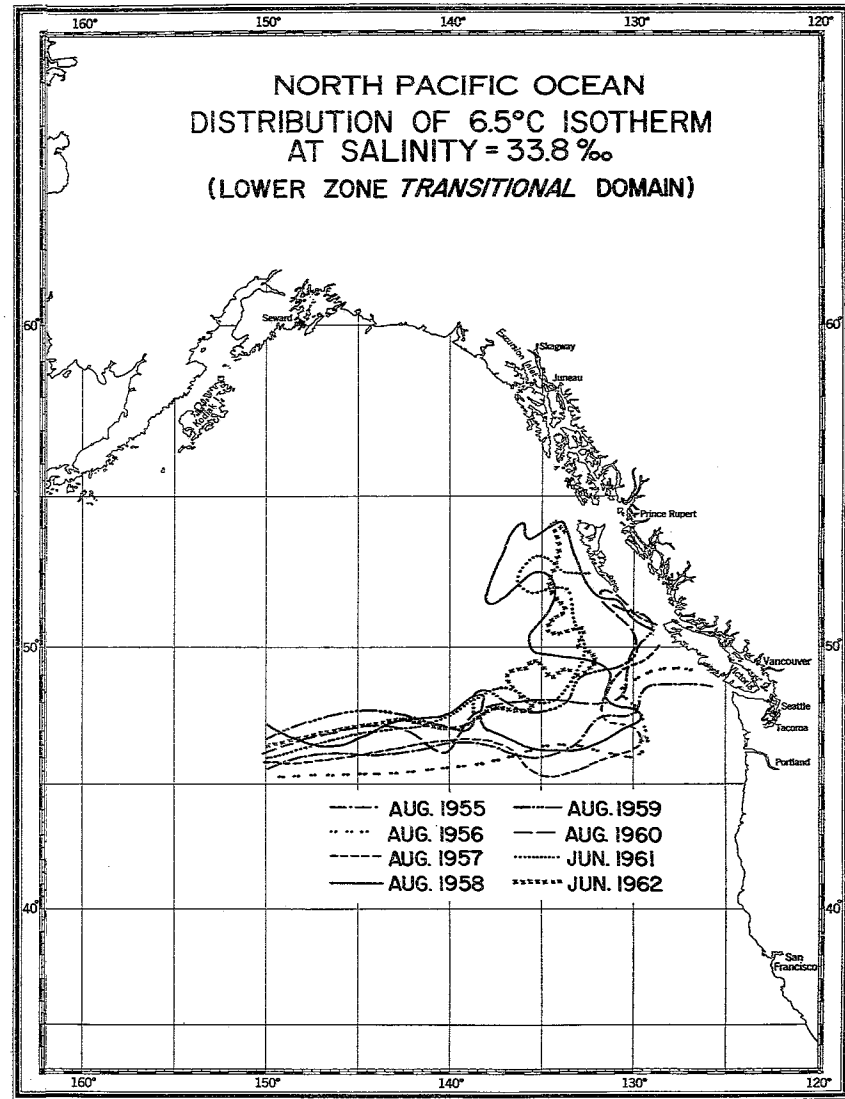

FIG. 11

S-148A

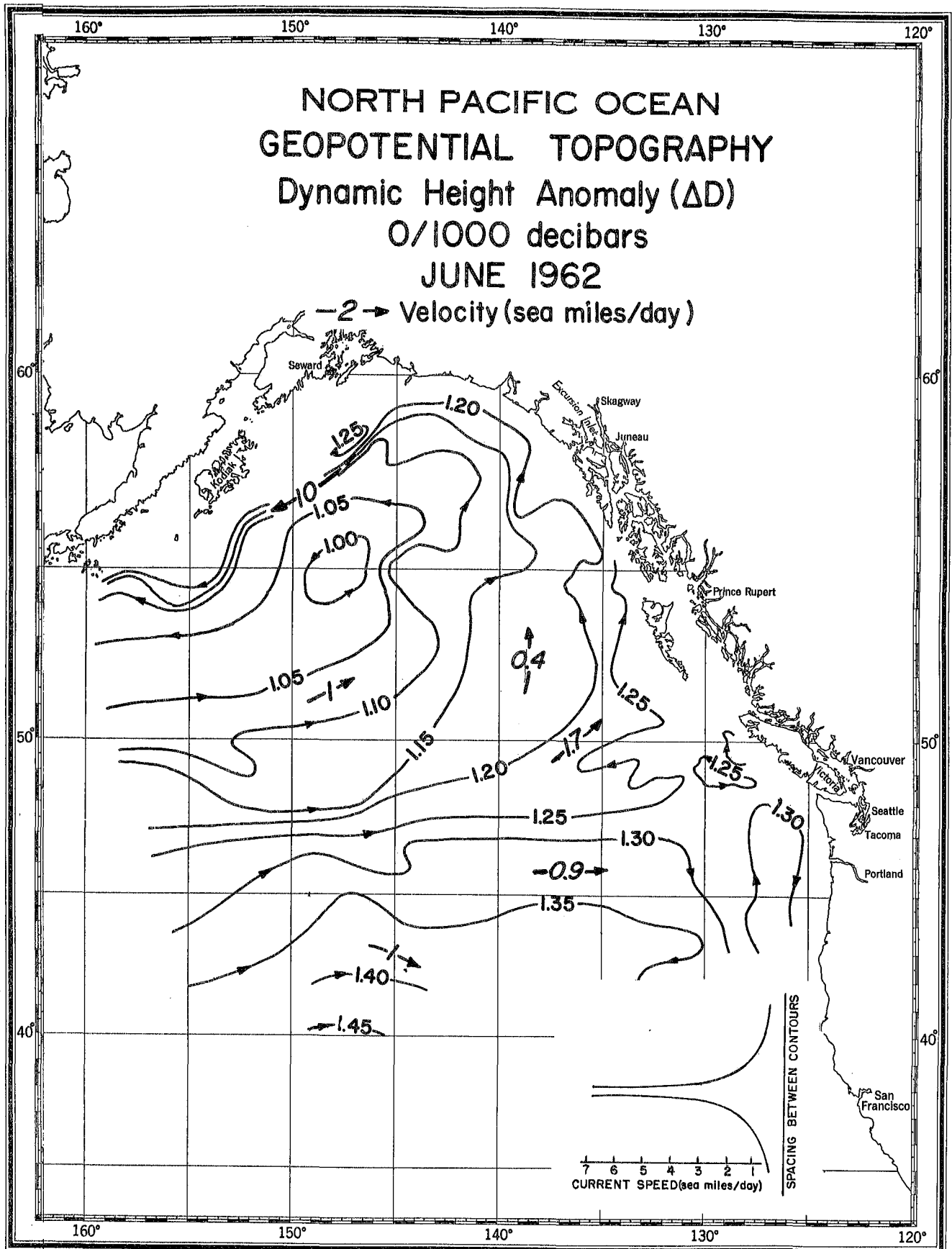

FIG. 12

S-148A

D. 11/1/62

FISHERIES RESEARCH BOARD OF CANADA  
Pacific Oceanographic Group  
Nanaimo, B. C.

Circular 1962 - 23  
October 26, 1962

B.C. Coastal Seawater Temperatures  
July, August, September, 1962

Introduction

A weekly report of the daily seawater temperatures observed at four light-stations - Triple Island, McInnes Island, Entrance Island and Amphitrite Point - is broadcast on Wednesday mornings from radio station CBU. A report of the monthly mean seawater temperature (computed from the daily observations between the 1st and 27th) is received from three other lightstations, at Langara Island, Cape St. James and Kains Island. These monthly temperature reports are transmitted to the San Diego Biological Laboratory of the U.S. Bureau of Commercial Fisheries for use in their monthly sea-surface temperature charts of the Eastern Pacific Ocean.

This circular is a summary of the data in all these reports for the months of July, August and September, 1962.

The monthly mean temperature data are presented in Table 1, which also lists the month-to-month anomaly, the 1962-to-1961 anomaly, and the classification index. This index represents the number of  $\frac{1}{2}$  standard deviation units there are in the anomaly of the monthly mean temperature with the 10-year average of the monthly mean. A classification index of 2 or more would indicate a significant departure from normal temperature levels. A positive (+) index indicates a warmer anomaly and a negative (-) index indicates a colder anomaly.

The data from the eight stations are grouped into 3 main geographical regions in Table 1 for ease of summarizing the reports, and these groupings do not necessarily mean that the stations in a group respond similarly to meteorological and oceanographic reactive forces.

The ocean coast

The seawater temperatures observed at the four stations located on the ocean coast - Langara, Cape St. James, Kains and Amphitrite - were generally normal for the months of July and August. Amphitrite showed the only significant colder deviation from the 10-year mean. September was a month of change, where the general ocean coast temperature conditions could be considered as average, but individual station conditions were quite variable. Temperatures at Langara for September were a -3 classification, definitely colder than average, whilst at Cape St. James the temperature report shows a tendency to warmer than average conditions.

When comparing 1962 water temperature conditions with those of 1961, there is an overall trend of colder-than-1961 conditions. The anomaly was greatest in July (about 3 F°) and gradually decreased to less than 1 F° in September. Again, this latter month was one of variable trends showing considerable change in individual station reports.

Warmest temperatures were generally recorded in August, with the usual seasonal cooling trend taking effect in September; except at Cape St. James. At this station, September was the warmest month. This could be due to an influx of a tongue of warmer oceanic water.

#### Northern B.C. coastal waters

Reports from Triple and McInnes show that seawater temperatures in July were colder than average, and that during the following two months, conditions were average. The colder-than-1961 anomaly was greatest in July (about 2.5 F°) and decreased to about 0.5 F° in September. August temperatures were the warmest, and a definite seasonal cooling trend became apparent in the September reports. Temperatures at McInnes were generally 1.5 F° warmer than at Triple, which difference is generally maintained throughout the summer months.

#### Southern B.C. coastal waters

The weather over the lower mainland regions was quite cool in July and August, and considerably warmer in September. These weather conditions are reflected to some degree in the seawater temperature reports for Entrance Island and Departure Bay. July temperatures were average, but August temperatures were significantly colder than average, showing the probable cumulative effect of low summer heating. September temperature conditions were quite opposite, and were significantly warmer than average. The seasonal warming-up rate was positive in July, but during August a significant cooling trend developed, so that August temperatures were cooler than in July. This cooling rate decreased to a more normal amount in September.

The colder-than-1961 anomaly was about 1.5 F° in July, but increased to 4.5 F° in the cold August, and reversed itself to a warmer-than-1961 anomaly in September. This warmer-than-1961 anomalous condition was also evident in the seawater temperature at Amphitrite in September, so it was probably the result of warmer weather that extended over the whole southern B.C. coastal region.

#### General summary

Seawater temperature conditions during July, August and September for the B.C. coastal region were generally average, except in the Strait of Georgia region, where abnormal local weather affected seawater conditions to give colder-than-average temperatures in August and warmer-than-average temperatures in September. There was an overall trend of colder-than-1961 conditions, except for September in the Strait of Georgia. August was generally the warmest month of the year.

Table 1. Monthly means, anomalies ( $\Delta$ ) and classifications of B.C. coastal seawater temperatures ( $^{\circ}$ F) July, August, September, 1962.

Station	July Temp.	July-June $\Delta$	July $\Delta$ 1962-1961	Classification
Langara I.	51.1	-	-1.5	-0
Cape St. James	52.0	+3.1	-3.4	-1
Kains I.	54.5*	+1.8	-2.1	+0
Amphitrite Pt.	52.2	+0.3	-5.2	-2
Triple I.	52.9	+3.1	-2.9	-3
McInnes I.	53.8	+2.1	-1.8	-1.0**
Entrance I.	62.8	+4.2	-1.3	+0
Departure Bay	63.2	+3.7	-1.5	-0

Station	Aug. Temp.	Aug-July $\Delta$	Aug. $\Delta$ 1962-1961	Classification
Langara I.	52.3*	+1.2	-0.1	-0
Cape St. James	53.3*	+1.3	-4.2	-1
Kains I.	55.1*	+0.6	-1.8	-0
Amphitrite Pt.	55.6	+3.4	-1.1	-0
Triple I.	54.5	+1.6	-1.8	-0
McInnes I.	56.0	+2.2	-0.9	-0.4**
Entrance I.	59.8	-3.0	-4.9	-3
Departure Bay	60.8	-2.4	-4.3	-2

Station	Sept. Temp.	Sept.-Aug. $\Delta$	Sept. $\Delta$ 1962-1961	Classification
Langara I.	51.9*	-0.4	-1.2	-3
Cape St. James	54.3*	+1.0	+0.0	+1
Kains I.	54.3*	-0.8	-1.3	-2
Amphitrite Pt.	55.5	-0.1	+0.6	+0
Triple I.	53.2	-1.3	-0.4	-0
McInnes I.	54.9	-1.1	-0.7	-0.2**
Entrance I.	59.2	-0.6	+1.1	+2
Departure Bay	59.8	-1.0	+1.7	+2

\* 1-27 mean

\*\*  $\Delta$  from 8-yr. av'ge.

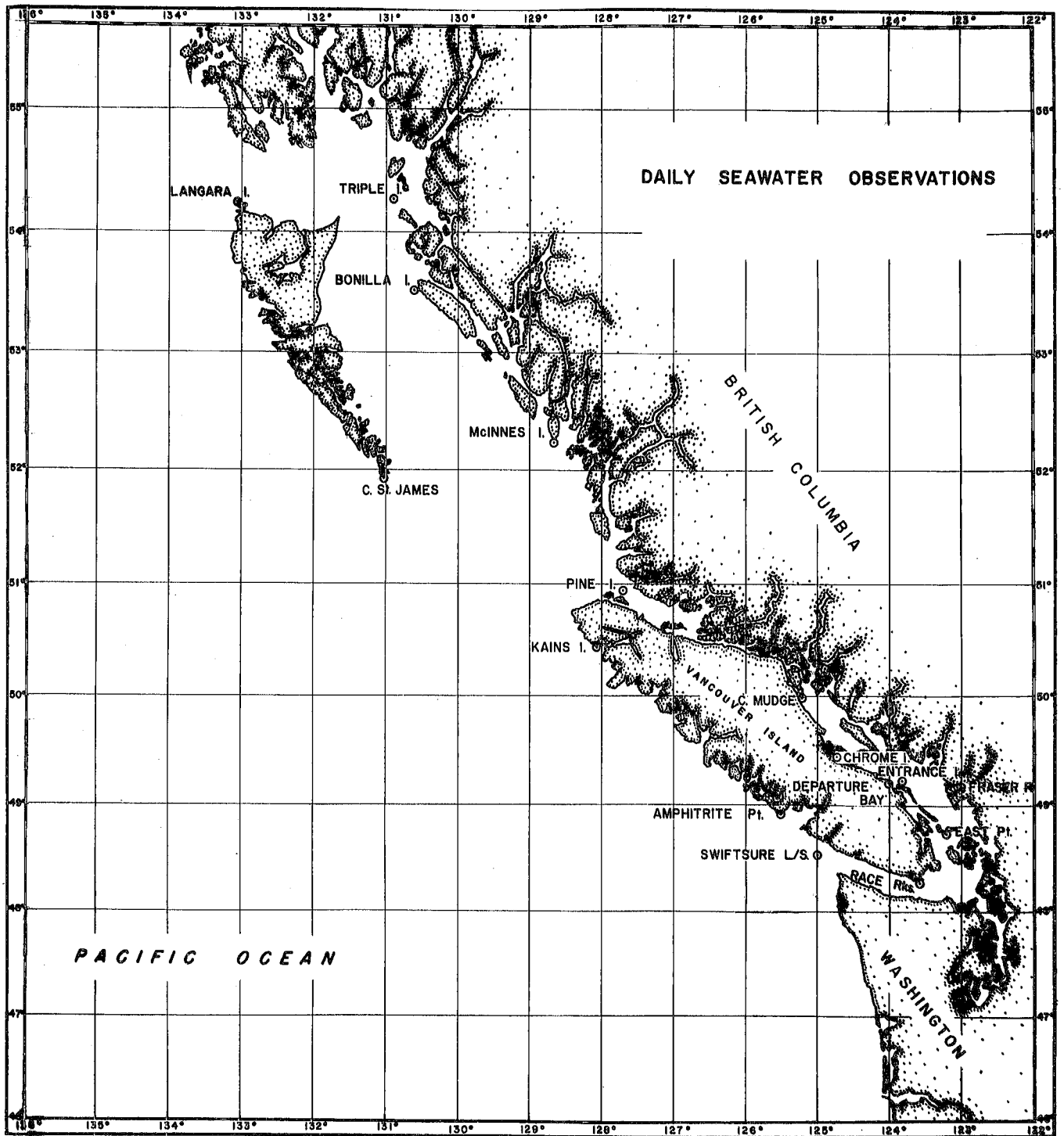

Figure 1. Location of stations making daily seawater observations.

FISHERIES RESEARCH BOARD OF CANADA  
Pacific Oceanographic Group  
Nanaimo, B. C.

Circular 1962-24  
December 17, 1962.

Preliminary assessment of oceanographic conditions observed  
during the Pacific Naval Laboratory Polar Pack Operation #1,  
April 17-May 12, 1962

Acoustic experiments were made in the Canadian Basin of the Arctic Ocean (Fig. 1) in three phases. The first was the measurement of cross-basin underwater sound transmissions between Ice Islands Arlis II, T3 and Ice Camp I. The ice islands were occupied by personnel of United States Underwater Sound Laboratory and Lamont Geophysical Laboratory, while Ice Camp I was occupied by personnel from Pacific Naval Laboratory and Pacific Oceanographic Group. (Polar Pack group). The second phase was similar except that Ice Camp 2 was occupied instead of Ice Camp 1. The third phase was a sound transmission shot-run made by the Polar Pack Group along a line over the Continental Shelf from Camp 2. The Canadian Group was directed by Mr. A.R. Milne of Pacific Naval Laboratory. Other personnel engaged in the operation were: T. Hughes, J. O'Malia (Pacific Naval Laboratory); T. Harwood (Defence Research Board, Ottawa); R.H. Herlinveaux (Pacific Oceanographic Group).

Personnel and equipment were flown into Mould Bay, Prince Patrick Island, (Joint Canadian-United States Weather Station) by RCAF Air Transport Command in a C-130 from Vancouver, B.C. The party was then transported out to Ice Camp 1 from Mould Bay by RCAF DC-3 aircraft (2500 lb in each aircraft). The camp was established on an ice lead approximately 4000 ft by 400 ft, 3.5 to 4 ft thick and approximately 130 miles off shore.

The original plan was to complete the observation at this camp then move to about 300 miles off shore and set up another camp. This plan had to be abandoned because of the damage to one DC-3, and the demand of other commitments on the RCAF aircraft. The plan was changed and personnel and equipment were transported by RCAF-ATC to Isachsen (Fig. 1), the base of the Polar Continental Shelf Project. From here the party and equipment were flown out by "Otter" aircraft to an ice camp which had been set up by the Continental Shelf Project for carrying out surveys on the Continental Shelf. This camp was on an ice lead approximately 500 ft wide, 1500 ft long and 7 to 8 ft thick. It was situated approximately 60 miles north of Borden Island, Fig. 1.

Seven serial oceanographic observations and sixteen bathythermograph lowerings were made at Camps 1 and 2, and at Arlis II during the period April 27 to May 11, 1962. Five Fjarlie bottles were used for the serial observations. Each was equipped with protected an unprotected thermometers. The salinity samples were drawn and stored in citrate bottles. These samples were analyzed at Nanaimo, B.C. on a conductivity salinometer. One of the seven stations was taken at Arlis II with Nansen bottles by G. Brusca (U of South California). The samples were titrated at Pt. Barrow by W. Senior (U.S. Hydrographic Office).

The data were computed on an ALWAC III-E digital computer at the University of British Columbia, to be published in a manuscript report series of Fisheries Research Board.

#### Phase I (24 April-2 May)

Oceanographic observations were made at Camp 1 during this phase, and combined with data observed at Arlis II during the following week (Phase II) to define the structure. Figure 2 shows the temperature, salinity and sound velocity structure along with the accepted classification of water masses.

The data show that there is a temperature maximum associated with the Pacific Water<sup>1</sup> overlying a minimum in the surface immediate water. The temperature increases with depth to a maximum on the Atlantic Water zone, than decreases to a minimum near the bottom of the Intermediate Lower Water zone. Below 2000 metres depth in the Arctic Residence Water, an adiabatic temperature increase is evident.

In the salinity structure two haloclines are evident, one associated with the Arctic-Pacific water interface and the other associated with the Pacific-Surface Intermediate Water zone.

The sound velocity increases throughout the depth. A near isovelocity condition occurs between 75 to 100 metres, where the effects of the temperature increase (Pacific layer) is nearly compensated for by an increase in salinity and pressure.

The sequence of bathythermograms shown in Figure 3 indicate that the temperature maximum in the Pacific Water zone appeared to oscillate between about 70 and 80 m in a period of about 6 hours.

#### Phase II (6-10 May)

Figure 4 shows the oceanographic structure observed at Camp 2 and at Arlis II (the same as in Fig. 2). The multiple oceanic zone structure appears to be modified at Camp 2 on the Continental Shelf. There were marked coincident thermocline and halocline from about 75 to 360 m depth. Above and below this structure the waters were nearly homogeneous.

#### Phase III (10 May)

The oceanographic data observed at the beginning and end of the occupancy of Camp 2 are shown in Fig. 5. The principal features of the structure are the coincident halocline and positive thermoclines, with near homogeneous zone above and below them. There are two thermoclines. It is believed that the upper one

---

<sup>1</sup>Pacific water is evident from Bering Strait northward and eastward in the Canadian Basin.

is a remnant of the Pacific Water maximum from the oceanic region (see Fig. 2). The change of depth of the structure during the period is believed to indicate an internal oceanic seiche.

During the period of occupancy, the suspended equipment hung vertically in the water. Evidently there was little or no motion relative to the ice cap. However on the final day (11 May) there was evident movement of the ice. Open water leads, parallel to the coast, appeared on the shoreward side of the camp. Evidently the onshore pressure on the ice (e.g. wind) relaxed or an offshore current developed in the water under the ice. The condition could not be resolved because it was necessary to abandon the camp hurriedly without making further observations.

The temperature-salinity relations shown in Fig. 6 confirm that there was no change of water mass during the period. The changes in structure (Fig. 5) were due to internal oscillations of about 25 m amplitude.

#### Acknowledgement

The author would like to thank the personnel of RCAF Air Transport Command, Continental Shelf Project (DM & TS), Joint Canadian-United States Weather Stations (Mould Bay and Isachsen) whose co-operation and assistance were appreciated.

R. H. Herlinveaux.

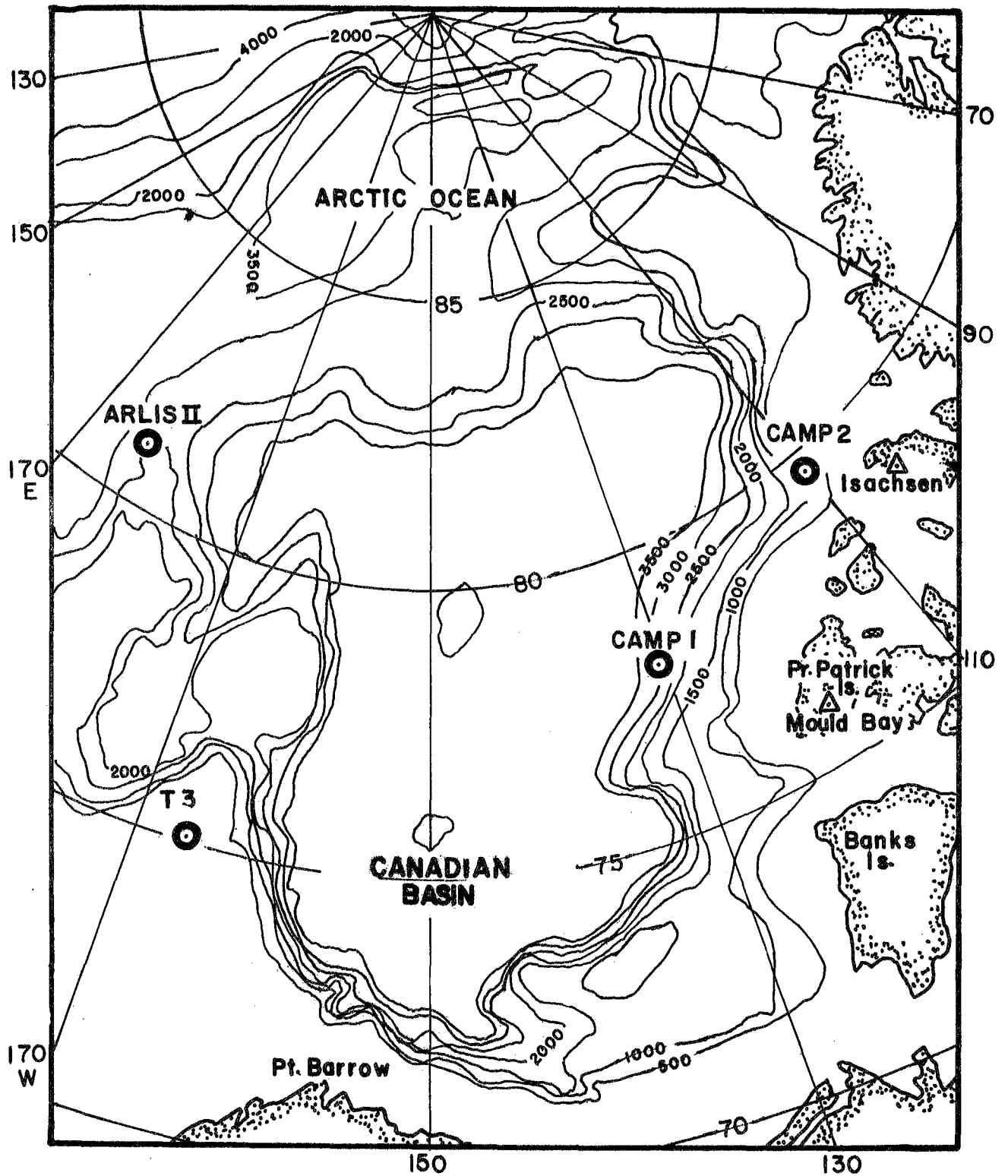

Figure 1.

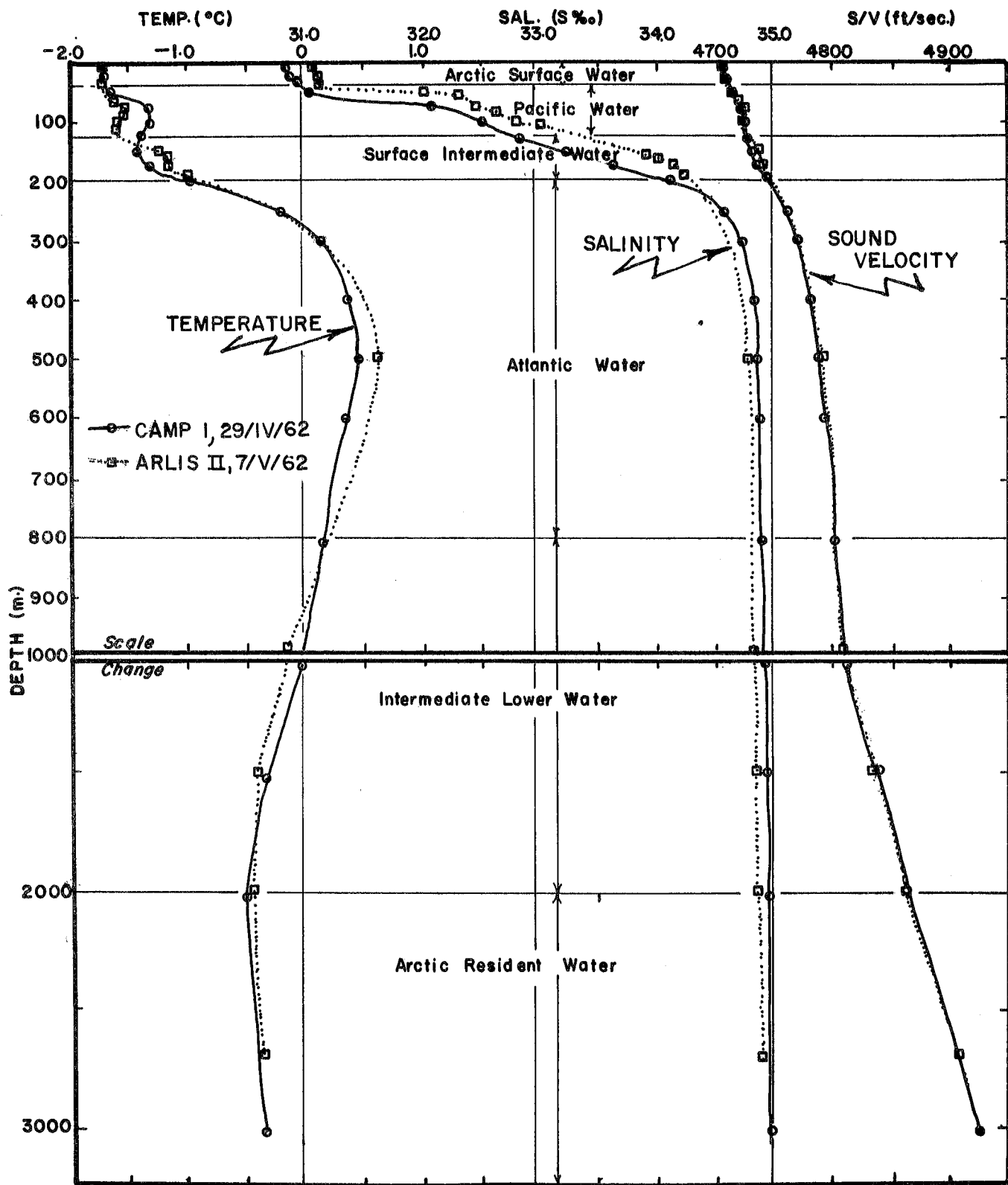

Figure 2.

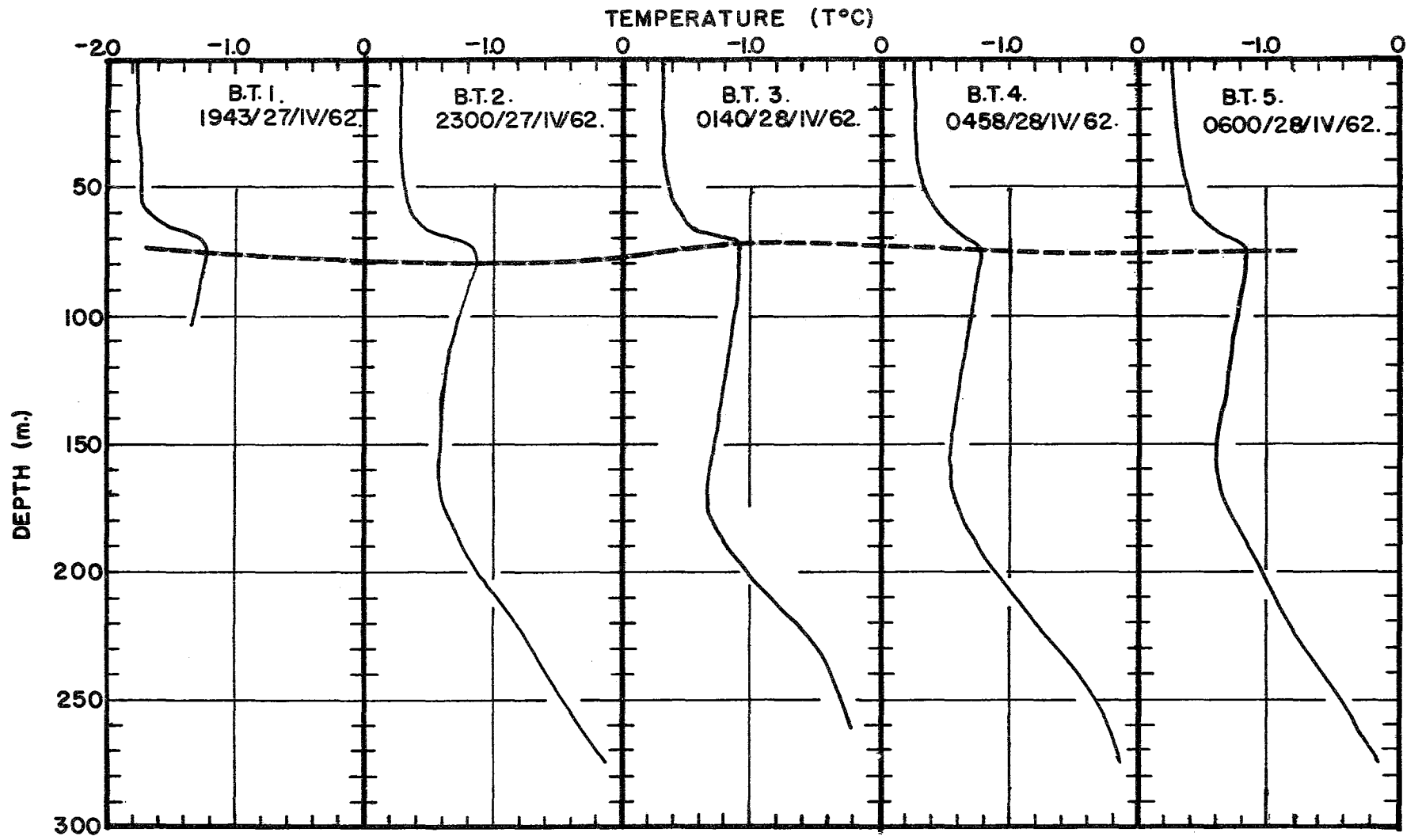

Figure 3.

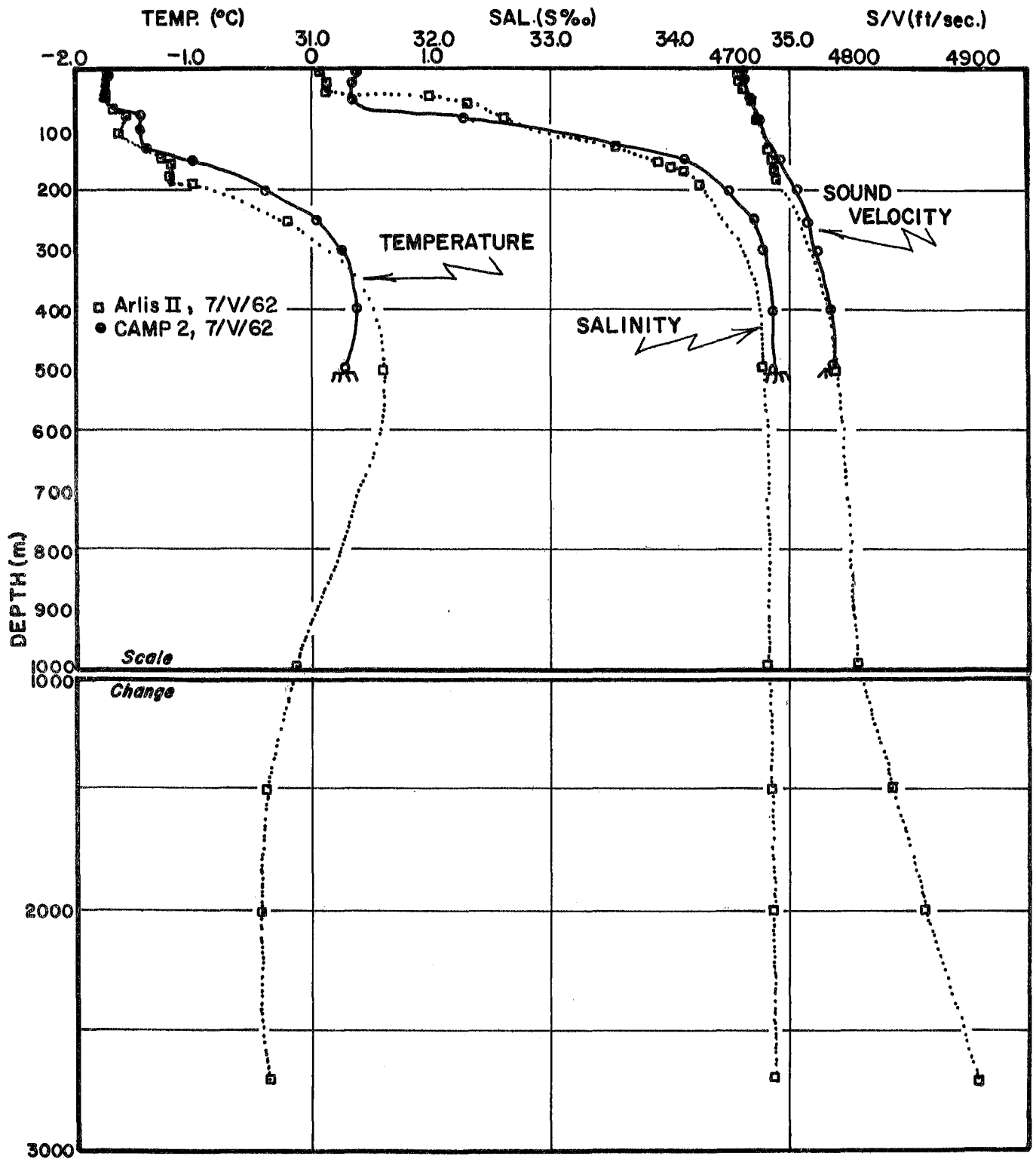

Figure 4.

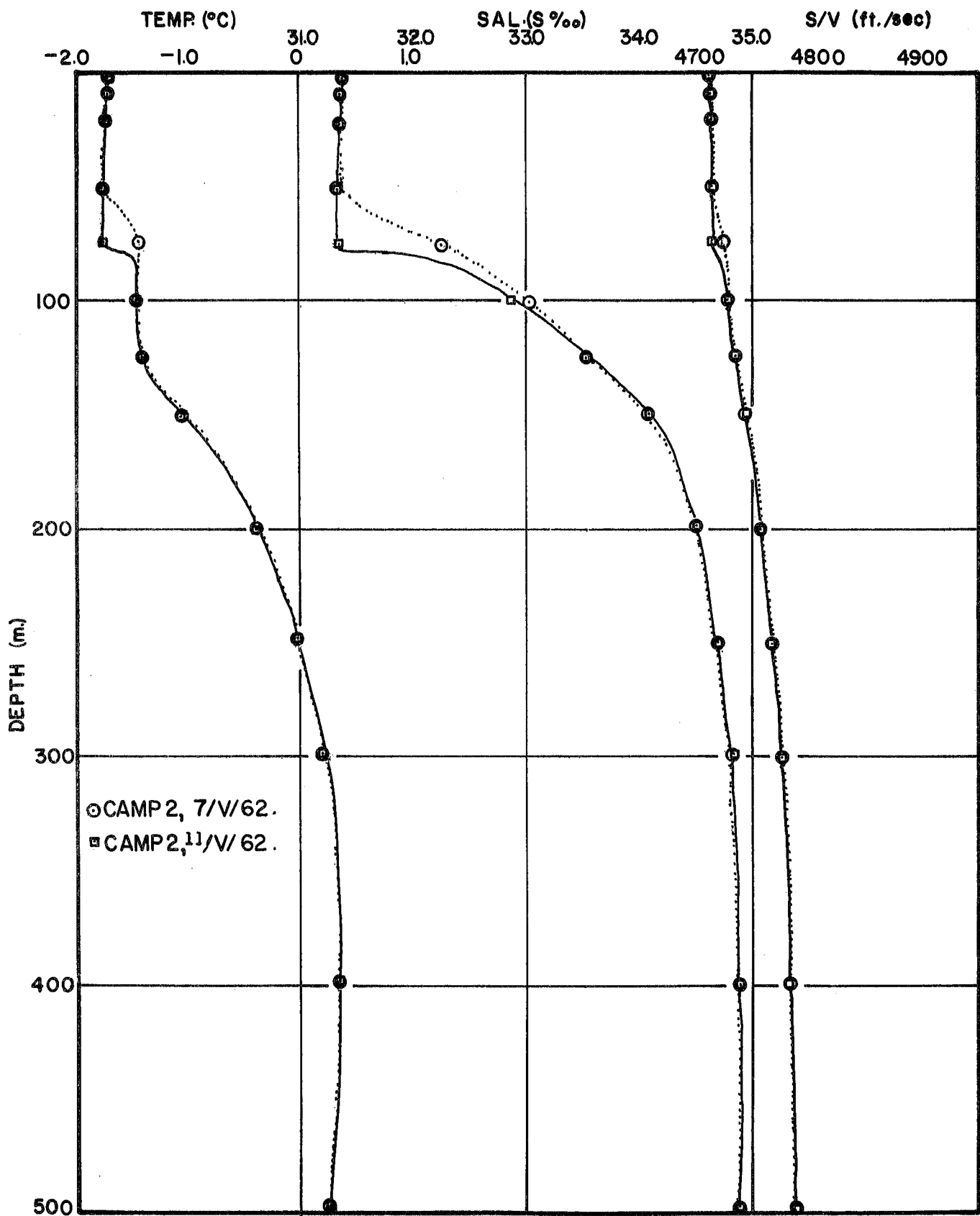

Figure 5.

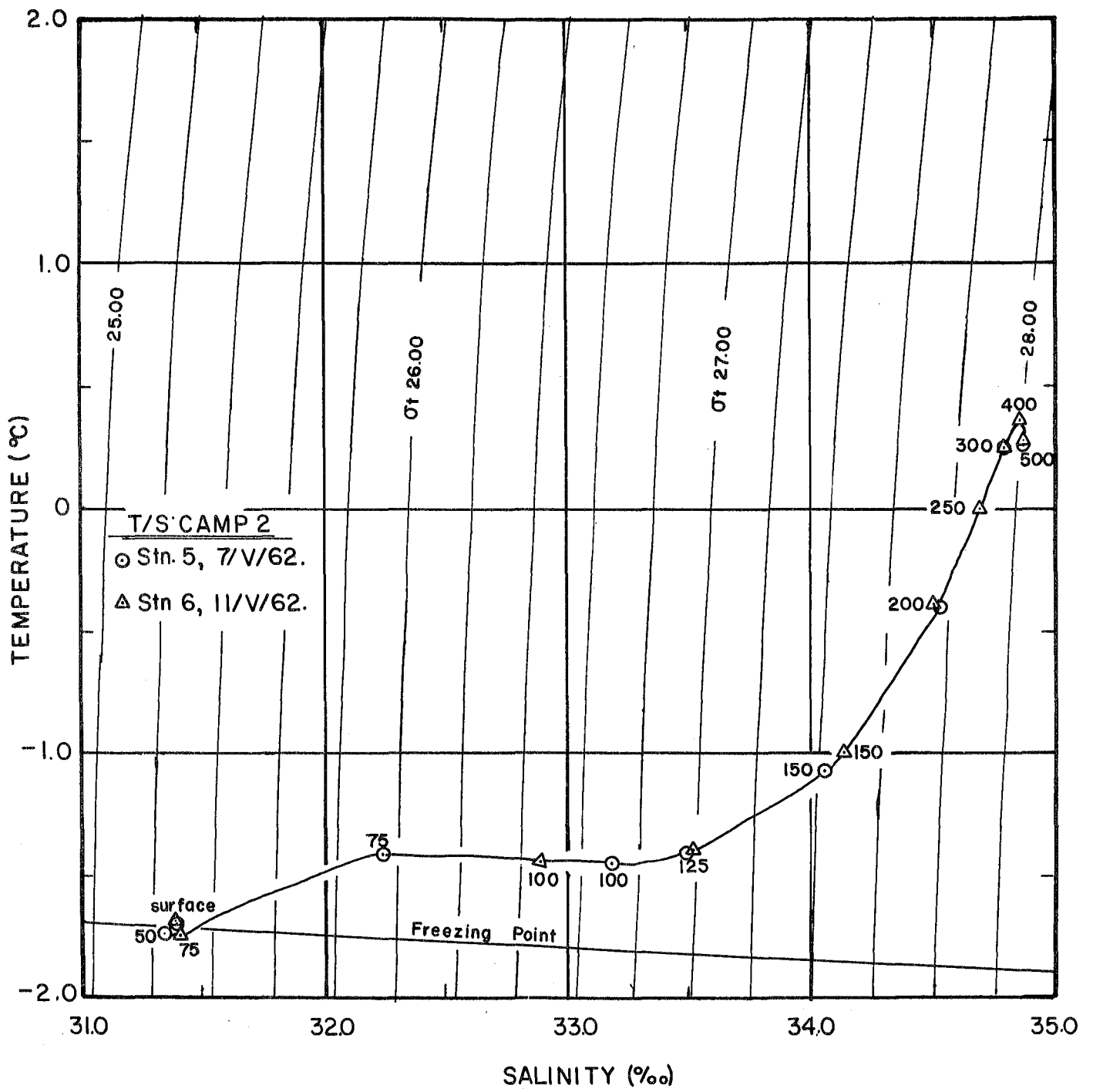

Figure 6.